



EEDEN07-760

technical data



air conditioning systems

Accessory Handbook

technical data



air conditioning systems

Accessory Handbook

CONTENTS

1	Table of contents	3
2	Drawings	33
3	Index	121

Table of contents

1

TABLE OF CONTENTS

1

1	AIR PURIFIERS	7
2	SPLIT	8
2-1	Wall mounted type FTK/XS-C/E / ATK/XS-D / ATX-E	8
2-2	Wall mounted type FTK/XS-DW/L / ATK/XS-E	8
2-3	Wall mounted type FTXG-E-W/S / ATXG-E / CTXG-E-W/S ..	8
2-4	Wall mounted type FT(Y)N-D/E	9
2-5	Wall mounted type FTXR-E	9
2-6	Floor standing type FVK/XS-B	10
2-7	Flexi type FLK/XS-B	10
2-8	4-Way blow ceiling mounted cassette FCQ-B	11
2-9	4-Way blow ceiling mounted cassette (small) FFQ-B	11
2-10	Ceiling suspended type FHQ-B	12
2-11	Concealed ceiling type FBQ-B	12
2-12	Concealed ceiling type FDBQ-B	13
2-13	Slim concealed ceiling type FDK/XS-C/E	13
2-14	Outdoor Units	13
3	SKY AIR	14
3-1	Wall mounted type FAQ-B	14
3-2	4-Way blow ceiling mounted cassette FCQ-B	14
3-3	4-Way blow ceiling mounted cassette FCQ-D	15
3-4	4-Way blow ceiling suspended cassette FUQ-B	15
3-5	Ceiling suspended type FHQ-B	16
3-6	Concealed ceiling type FBQ-B	16
3-7	Concealed ceiling type FDQ-B	17
3-8	Concealed ceiling type FDEQ-B	17
3-9	Concealed ceiling type FDYP-B	17
3-10	Condensing units for air handling applications (pair) ERX ..	18
3-11	Outdoor units	18
4	VRV	19
4-1	Wall mounted type FXAQ-MA	19
4-2	Floor standing type FXLQ-MA	19
4-3	Concealed floor standing type FXNQ-MA	20
4-4	2-Way blow ceiling mounted cassette FXCQ-M8	20
4-5	4-Way blow ceiling mounted cassette (small) FXZQ-M8 ...	21
4-6	4-Way blow ceiling mounted cassette FXFQ-M8	21
4-7	4-Way blow ceiling suspended cassette FXUQ-MA	22
4-8	Ceiling mounted cassette FXKQ-MA	22
4-9	Ceiling suspended type FXHQ-MA	23
4-10	Concealed ceiling type FXDQ-M8	23
4-11	Slim concealed ceiling type FXDQ-P/N	24
4-12	Concealed ceiling type FXSQ-M8	24

TABLE OF CONTENTS

	4-13	Concealed ceiling type FXMQ-MA	25
	4-14	Outdoor air processing unit FXMQ-MF	25
	4-15	Outdoor units	26
5		NETWORK SOLUTIONS	28
	5-1	DS net	28
	5-2	Intelligent touch Controller	28
	5-3	Intelligent Manager	28
	5-4	DMS-IF	28
	5-5	BACnet Gateway	29
	5-6	BMS	29
6		HRV	30
	6-1	VKM-GA	30
	6-2	VAM-FA	31

1 AIR PURIFIERS

Option name	MC707VM-W/S / MC707BFVM *1
Titanium apatite photocatalytic pleated filter for replacement	KAC972A4E
Bio-antibody filter for replacement	KAF972A4E

*1 UK model only

1
1

2 SPLIT

2 - 1 Wall mounted type FTK/XS-C/E / ATK/XS-D / ATX-E

1
2

Option name	FTK/XS-C / ATK/XS-D			FTK/XS-E / ATX50E		
	20	25	35	50	60	71
Wiring adapter for time clock / remote control *1	KRP413A1S					
Centralised control board up to 5 rooms *2	KRC72					
Central remote control	DCS302C51					
Unified ON/OFF control	DCS301B51					
Schedule timer	DST301B51					
Interface adapter *3	KRP928A2S					
Air purification filter with photocatalytic deodorising function (with frame)	KAF918A43					
Air purification filter with photocatalytic deodorising function (without frame)	KAF918A44					
Anti-theft protection for remote control	KKF917AA4					

*1 Wiring adapter supplied by Daikin. Time clock and other devices: field supply.
 *2 Wiring adapter is also required for each indoor unit.
 *3 Interface adapter for room air conditioners (DIII-NET).

2 - 2 Wall mounted type FTK/XS-DW/L / ATK/XS-E

Option name	FTK/XS-DW/L / ATK/XS-E			
	20	25	35	50
Wiring adapter for time clock / remote control *1	KRP413A1S			
Centralised control board up to 5 rooms *2	KRC72			
Central remote control	DCS302C51			
Unified ON/OFF control	DCS301B51			
Schedule timer	DST301B51			
Interface adapter *3	KRP928A2S			
Titanium apatite photocatalytic air purification filter (without frame)	KAF970A46			
Anti-theft protection for remote control	KKF917AA4			

*1 Wiring adapter is supplied by Daikin. Time clock and other devices: field supply.
 *2 Wiring adapter is also required for each indoor unit.
 *3 Interface adapter for room air conditioners (DIII-NET).

2 - 3 Wall mounted type FTXG-E-W/S / ATXG-E / CTXG-E-W/S

Option name	FTXG-E-W/S / ATXG-E		CTXG-E-W/S / ATXG-E
	25	35	50
Wiring adapter for time clock / remote control *1	KRP413A1S		
Centralised control board up to 5 rooms *2	KRC72		
Central remote control	DCS302C51		
Unified ON/OFF control	DCS301B51		
Schedule timer	DST301B51		
Interface adapter *3	KRP928A2S		
Titanium apatite photocatalytic air purification filter (with frame)	KAF952B41		
Titanium apatite photocatalytic air purification filter (without frame)	KAF952B42		
Anti-theft protection for remote control	KKF917AA4		

*1 Wiring adapter is supplied by Daikin. Time clock and other devices: field supply.
 *2 Wiring adapter is also required for each indoor unit.
 *3 Interface adapter for room air conditioners (DIII-NET).

2 SPLIT

2 - 4 Wall mounted type FT(Y)N-D/E

Option name	FT(Y)N-D		FT(Y)N-E	
	25	35	50	60
Wiring adapter for time clock / remote control *1	-	-	KRP413A1S	
Centralised control board up to 5 rooms *2	-	-	KRC72	
Central remote control	-	-	DCS302C51	
Unified ON/OFF control	-	-	DCS301B51	
Schedule timer	-	-	DST301B51	
Interface adapter *3	-	-	KRP928A2S	
Titanium apatite photocatalytic air purification filter (with frame)	KAF918A45		-	
Titanium apatite photocatalytic air purification filter (without frame)	KAF918A46		KAF952B42	
Anti-theft protection for remote control	KKF936A4		KKF917AA4	

*1 Wiring adapter is supplied by Daikin. Time clock and other devices: field supply.
 *2 Wiring adapter is also required for each indoor unit.
 *3 Interface adapter for room air conditioners (DIII-NET).

2 - 5 Wall mounted type FTXR-E

Option name	FTXR-E		
	28	42	50
Wiring adapter for time clock / remote control *1	KRP413A1S		
Centralised control board up to 5 rooms *2	KRC72		
Central remote control	DCS302C51		
Unified ON/OFF control	DCS301B51		
Schedule timer	DST301B51		
Interface adapter *3	KRP928A2S		
Air purification and deodorising filter set without frame	KAF974B42S		
Air supply filter with frame	KAF963A43		
Anti-theft protection for remote control	KKF936A4		

*1 Wiring adapter is supplied by Daikin. Time clock and other devices: field supply.
 *2 Wiring adapter is also required for each indoor unit.
 *3 Interface adapter for room air conditioners (DIII-NET).

2 SPLIT

2 - 6 Floor standing type FVK/XS-B

1
2

Option name	FVK/XS-B		
	25	35	50
Wiring adapter for time clock / remote control *1		KRP413A1S	
Centralised control board	up to 5 rooms *2	KRC72	
Central remote control		DCS302C51	
Unified ON/OFF control		DCS301B51	
Schedule timer		DST301B51	
Interface adapter *3		KRP928A2S	
Photocatalytic deodorising filter, with frame		KAZ917B41	
Photocatalytic deodorising filter, without frame		KAZ917B42	
Air purification filter with frame		KAF925B41	
Air purification filter without frame		KAF925B42	
Anti-theft protection for remote control		KKF917AA4	

*1 Wiring adapter is supplied by Daikin. Time clock and other devices; field supply.

*2 Wiring adapter is also required for each indoor unit.

*3 Interface adapter for room air conditioners (DIII-NET).

2 - 7 Flexi type FLK/XS-B

Option name	FLK/XS-B			
	25	35	50	60
Wiring adapter for time clock / remote control *1		KRP413A1S		
Centralised control board	up to 5 rooms *2	KRC72		
Central remote control		DCS302C51		
Unified ON/OFF control		DCS301B51		
Schedule timer		DST301B51		
Interface adapter *3		KRP928A2S		
Photocatalytic deodorising filter, with frame		KAZ917B41		
Photocatalytic deodorising filter, without frame		KAZ917B42		
Air purification filter with frame		KAF925B41		
Air purification filter without frame		KAF925B42		
Anti-theft protection for remote control		KKF917AA4		

*1 Wiring adapter supplied by Daikin. Time clock and other devices: field supply.

*2 Wiring adapter is also required for each indoor unit.

*3 Interface adapter for room air conditioners (DIII-NET).

2 SPLIT

2 - 8 4-Way blow ceiling mounted cassette FCQ-B

Option name			FCQ-B		
			35	50	60
Decoration panel			BYC125K		
Fresh air intake kit	Chamber type	without T-shape and fan	KDDP55D160		
		with T-shape	KDD55DA160K		
Sealing member of air discharge outlet			KDBHJ55B160		
Panel spacer			KDBP55H160W		
Remote control	Infrared	Heat pump	BRC7C512		
		Cooling only	BRC7C513		
	Wired	BRC1D52			
Adaptor for wiring (hour meter) *1			EKR1B2		
Wiring adaptor for electrical appendices *2			KRP4A53		
Wiring adaptor for electrical appendices *2			KRP1B57		
Remote sensor			KRCS01-1		
Installation box for adaptor PCB			KRP1C98		
Central remote control			DCS302C51		
Electrical box with earth terminal			KJB311A		
Unified on/off controller			DCS301B51		
Electrical box with earth terminal (2 blocks)			KJB212A		
Schedule timer			DST301B51		
Interface adaptor for Sky Air series			DTA112B51		
Remote "On/Off" and "Forced Off" kit			EKORO		
Noise filter (for electromagnetic interphase use only)			KEK26-1A		

*1 Possibility to connect an hour meter. This part should not be installed inside the equipment.
 *2 The installation box for adaptor PCB (KRP1C98) is necessary.

2 - 9 4-Way blow ceiling mounted cassette (small) FFQ-B

Option name			FFQ-B			
			25	35	50	60
Decoration panel			BYFQ60B			
Sealing member of air discharge outlet			KDBH44BA60			
Panel spacer			KDBQ44B60			
Fresh air intake kit	Direct Installation type		KDDQ44XA60			
Remote control	Infrared	Heat pump	BRC7E530			
		Cooling only	BRC7E531			
	Wired	BRC1D52				
Central remote control			DCS302C51			
Unified ON/OFF control			DCS301B51			
Schedule timer			DST301B51			
Adaptor for wiring (interlock for fresh air intake) *1			KRP1B57			
Wiring adapter for electrical appendices (2) *1			KRP4A53			
Installation box for adapter PCB			KRP1BA101			
Remote sensor			KRCS01-1			
Interface adapter for Sky Air series			DTA112B51			

All options are supplied as kit.
 *1 The "Installation box for adapter PCB" is required.

2 SPLIT

2 - 10 Ceiling suspended type FHQ-B

1
2

Option name		FHQ-B		
		35	50	60
Replacement long-life filter		KAF501DA56		KAFJ501DA80
Drain up kit		KDU50M60		
L-type piping kit (for upward direction)		KHFP5M35	KHFP5M63	
Remote control	Wired type	BRC1D52		
	Infrared type	Heat pump	BRC7E63	
		Cooling only	BRC7E66	
Central remote control		DCS302C51		
Unified ON/OFF control		DCS301B51		
Schedule timer		DST301B51		
Adapter for wiring		KRP1B54		
Wiring adapter (hour meter)		EKR1B2		
Adaptor for external ON/OFF and monitoring *1		KRP4A52		
Interface adapter for Sky Air series		DTA112B51		
Installation box for adapter PCB		KRP1C93		
Remote ON/OFF, forced OFF		EKRORO		

*1 Installation box for adapter PCB (KRP1C93) is necessary.

2 - 11 Concealed ceiling type FBQ-B

Option name		FBQ-B		
		35	50	60
Panel related	Decoration panel	BYB545D		BYB571D
	Service access panel	KTBJ25K56W		KTBJ25K80W
Filter related	High-efficiency filter 65% (colorimetric method) *1	KAFJ252L56		KAFJ252L80
	High-efficiency filter 90% (colorimetric method) *1	KAFJ253L56		KAFJ253L80
	Filter chamber for bottom suction	KAJ25L56D		KAJ25L80D
	Filter chamber for rear suction	KAJ25L56B		KAJ25L80B
Air inlet and air discharge outlet related	Air suction canvas	KSA-25K56		KSA-25KA80
	Air discharge adapter for round duct	KDAJ25K56		KDAJ25K71
Remote control	Wired type	BRC1D52		
Central remote control		DCS302C51		
Unified ON/OFF control		DCS301B51		
Schedule timer		DST301B51		
Adapter for wiring (interlock for fresh air intake fan)		KRP1B54		
Wiring adaptor for electrical appendices		KRP4A51		
Interface adapter for Sky Air series		DTA112B51		
Remote "On/Off" and "Forced Off" kit		EKRORO		
Option PCB for external electrical heater, humidifier and/or hour meter *2		EKR1B2		

*1 If installing a high efficiency filter on the unit, an assembly chamber for either bottom or rear suction is required.
*2 Electrical heater, humidifier and hour meter are field supply. These parts should not be installed inside the equipment. (Refer to installation manual EKR1B2).

2 SPLIT

2 - 12 Concealed ceiling type FDBQ-B

Option name		FDBQ25B
Remote control	Wired type	BRC1D52
Wiring adapter (hour meter) *1		EGRP1B2

*1 Possibility to connect an hour meter. This part should not be installed inside the equipment.

1
2

2 - 13 Slim concealed ceiling type FDK/XS-C/E

Option name	FDK/XS-E		FDK/XS-C	
	25	35	50	60
Wiring adapter for time clock / remote control *1	KRP413A1S			
Centralised control board	up to 5 rooms *2		KRC72	
Central remote control	DCS302C51			
Unified ON/OFF control	DCS301B51			
Schedule timer	DST301B51			
Interface adapter *3	KRP928A2S			
Anti-theft protection for remote control	KKF917AA4			

*1 Wiring adapter is supplied by Daikin. Time clock and other devices: field supply.
 *2 Wiring adapter is also required for each indoor unit.
 *3 Interface adapter for room air conditioners (DIII-NET).

2 - 14 Outdoor Units

Option name	RK/XS-D RXG-E RK/XH-C R(Y)N-D 2MK/XS40D ARK/XS-E ARXG-E ARK/XH-C 2AMK/XS40B			RK/XS-E R(Y)N-E ARXS-E MKS50-58-75-90E MXS52-68-80-90E AMX52E		
	20	25	35	50	60	71
Air direction adjustment grille	KPW937A4			KPW945A4		

Option name	RXR-E		
	28	42	50
Air direction adjustment grille	KPW937A4		
Drain plug	KKP937A4		
Extension hose set for humidification	KPMH974A402		
Relay joint for humidification	KPMJ942A4		
L-shape cuffs for humidification	KPMH950A4L		
Hose for humidification	KPMH942A4Z		

3 SKY AIR

3 - 1 Wall mounted type FAQ-B

1
3

Option name			FAQ-B	
			71	100
Remote control	Wired		BRC1D52	
	Infrared type	Heat pump	BRC7E618	BRC7C510
		Cooling only	BRC7E619	BRC7C511
Wiring adapter for electrical appendices *1			KRP4A51	
Installation box for adapter PCB			KRP4A93	-
Central remote control			DCS302C51	
Electrical box with earth terminal (3 blocks)			KJB311A	
Unified ON/OFF control			DCS301B51	
Electrical box with earth terminal (2 blocks)			KJB212A	
Schedule timer			DST301B51	
Interface adapter for Sky Air series			-	DTA112B51
Remote sensor			KRCS01-1	-
Drain up kit			K-KDU572CVE	-
Connector for forced on, forced off			-	EKRORO
Noise filter (for electromagnetic interface use only)			KEK26-1A	

*1 Installation box (KRP4A93) is necessary for KRP4A51.

3 - 2 4-Way blow ceiling mounted cassette FCQ-B

Option name			FCQ-B		
			71	100	125
Decoration panel			BYC125K		
Fresh air intake kit	Chamber type	without T-shape and fan	KDDP55D160		
		with T-shape	KDD55DA160K		
Sealing member of air discharge outlet			KDBHJ55B160		
Panel spacer			KDBP55H160W		
Remote control	Infrared	Heat pump	BRC7C512		
		Cooling only	BRC7C513		
	Wired		BRC1D52		
Adaptor for wiring (hour meter) *1			EKRP1B2		
Wiring adaptor for electrical appendices *2			KRP4A53		
Wiring adaptor for electrical appendices *2			KRP1B57		
Remote sensor			KRCS01-1		
Installation box for adaptor PCB			KRP1C98		
Central remote control			DCS302C51		
Electrical box with earth terminal			KJB311A		
Unified on/off controller			DCS301B51		
Electrical box with earth terminal (2 blocks)			KJB212A		
Schedule timer			DST301B51		
Interface adaptor for Sky Air series			DTA112B51		
Remote "On/Off" and "Forced Off" kit			EKRORO		
Noise filter (for electromagnetic interphase use only)			KEK26-1A		

*1 Possibility to connect an hour meter. This part should not be installed inside the equipment.
*2 The installation box for adaptor PCB (KRP1C98) is necessary.

3 SKY AIR

3 - 3 4-Way blow ceiling mounted cassette FCQ-D

Option name			FCQ-D			
			71	100	125	140
Decoration panel			BYCP125DJW1			
Panel spacer			KDBP55H160W			
Fresh air intake kit	Chamber type	without T-shape and fan	KDDP55D160			
		With T-shape, without fan	KDD55DA160K			
Remote control	Wired type		BRC1D52			
	Infrared type		BRC7E51			
Central remote control			DCS302C51			
Unified on/off controller			DCS301B51			
Schedule timer			DST301B51			
Adapter for wiring *1			KRP1B59			
Wiring adapter for electrical appendices *1			KRP4A53			
Installation box for adapter PCB			KRP1D98			

*1 Installation box for adapter PCB (KRP1D98) is necessary

1
3

3 - 4 4-Way blow ceiling suspended cassette FUQ-B

Option name			FUQ-B		
			71	100	125
Sealing member of air discharge outlet			KDBH49FA80	KDBHJ49F140	
Decoration panel for air discharge			KDBTJ49F80	KDBTJ49F140	
Vertical flap kit			KDGI49F80	KDGI49F140	
Replacement long-life filter			KAF495FA140		
L connection piping kit			KHFP49MA140		
Remote control	Wired type		BRC1D52		
	Infrared type	Heat pump	BRC7C528		
		Cooling only	BRC7C529		
Central remote control			DCS302C51		
Unified on/off controller			DCS301B51		
Schedule timer			DST301B51		
Wiring adapter for electrical appendices *1			KRP4A53		
Interface adapter for Sky Air series			DTA112B51		
Installation box for adapter PCB			KRP1B97		
Remote sensor			KRCS01-1		
Connector for forced on, forced off			EKRORO		
Electrical box with earth terminal (3 blocks)			KJB311A		
Electrical box with earth terminal (2 blocks)			KJB212A		

*1 Installation box for adapter PCB (KRP1B97) is necessary.

3 SKY AIR

3 - 5 Ceiling suspended type FHQ-B

1
3

Option name		FHQ-B		
		71	100	125
Replacement long-life filter		KAFJ501DA80	KAF501DA112	KAF501DA160
Drain up kit			KDU50M125	
L-type piping kit (for upward direction)			KHFP5MA160	
Remote control	Wired type		BRC1D52	
	Infrared type	Heat pump	BRC7E63	
		Cooling only	BRC7E66	
Central remote control			DCS302C51	
Unified ON/OFF control			DCS301B51	
Schedule timer			DST301B51	
Adapter for wiring			KRP1B54	
Wiring adapter for electrical appendices *1			KRP4A52	
Interface adapter for Sky Air series			DTA112B51	
Installation box for adapter PCB			KRP1C93	
Remote sensor			KRCS01-1	
Connector for forced on, forced off			EKRORO	
Electrical box with earth terminal (3 blocks)			KJB311A	
Electrical box with earth terminal (2 blocks)			KJB212A	

*1 Installation box for adapter PCB (KRP1C93) is necessary.

3 - 6 Concealed ceiling type FBQ-B

Option name		FBQ-B		
		71	100	125
Panel related	Decoration panel	BYB571D		BYB5125D
	Service access panel	KTBJ25K80W		KTBJ25K160W
Filter related	High-efficiency filter 65% (colorimetric method) *1	KAFJ252L80		KAFJ252L160
	High-efficiency filter 90% (colorimetric method) *1	KAFJ253L80		KAFJ253L160
	Filter chamber for bottom suction	KAJ25L80D		KAJ25L160D
	Filter chamber for rear suction	KAJ25L80B		KAJ25L160B
Air inlet and air discharge outlet related	Air suction canvas	KSA-25KA80		KSA-25K160
	Air discharge adapter for round duct	KDAJ25K71		KDAJ25K140
Remote control	Wired type		BRC1D52	
Central remote control			DCS302C51	
Unified ON/OFF control			DCS301B51	
Schedule timer			DST301B51	
Adapter for wiring (interlock for fresh air intake fan)			KRP1B54	
Wiring adaptor for electrical appendices			KRP4A51	
Interface adapter for Sky Air series			DTA112B51	
Remote "On/Off" and "Forced Off" kit			EKRORO	
Option PCB for external electrical heater, humidifier and/or hour meter *2			EKRP1B2	

*1 If installing a high efficiency filter on the unit, an assembly chamber for either bottom or rear suction is required.
*2 Electrical heater, humidifier and hour meter are field supply. These parts should not be installed inside the equipment. (Refer to installation manual EKRP1B2).

3 SKY AIR

3 - 7 Concealed ceiling type FDQ-B

Option name	FDQ-B		
	125	200	250
Wiring adaptor for electrical appendices	KRP4A51		
Adapter for wiring (interlock for fresh air intake)	KRP1B54		
Interface adapter for Sky Air series	DTA112B51		
Central remote control	DCS302C51		
Unified ON/OFF control	DCS301B51		
Schedule timer	DST301B51		
Option PCB for electrical heater, humidifier and/or hour meter. *1	EKRP1B2		
Remote control	Wired type	BRC1D52	
Remote ON/OFF, forced OFF	EKRORO		

*1 Electrical heater, humidifier and hour meter are field supply. These parts should not be installed inside the equipment. (Refer to installation manual EKRP1B2).

1
3

3 - 8 Concealed ceiling type FDEQ-B

Option name	FDEQ-B		
	71	100	125
Remote control	Wired type	BRC1D52	
Wiring adaptor for electrical appendices	KRP4A51		
Wiring adaptor (hour meter)	EKRP1B2		
Remote "On / Off" and "Forced Off" kit	EKRORO		

3 - 9 Concealed ceiling type FDYP-B

Option name	FDYP-B	
	200	250
Wired remote control	BRC1D52	
Central remote control	DCS302C51	
Unified ON/OFF control	DCS301B51	
Schedule timer	DST301B51	
Wiring adapter for electrical appendices	KRP4A51	
Adapter for wiring (interlock for fresh air intake)	KRP1B54	
Interface adapter for sky air series	DTA102A52	
Option PCB for ext. elec. heater, humidifier and/or hour meter *1	EKRP1B2	
Remote ON/OFF, forced OFF	EKRORO	

*1 Electrical heater, humidifier and hour meter are field supply. These parts should not be installed inside the unit.

3 SKY AIR

3 - 10 Condensing units for air handling applications (pair) ERX

1
3

Option name	ERX-A					
	V3			W1		
	100	125	140	125	200	250
Central drain plug	KKPJ5F180			-		
Central drain pan kit	-			KWC26B160	KWC26B280	
AHU inverter Control-Box pair	EKEXD/CBA					
	EKEXF/CBA					
AHU inverter EXV-Kit	EKE XV63		-	EKE XV63	-	-
	EKE XV80			-		
	EKE XV100			-		
	EKE XV125			-		
	EKE XV140			-		
	-			EKE XV200		
	-			EKE XV250		

3 - 11 Outdoor units

Option name	REQ-B		
	71	100	125
Central drain plug	KKPJ5F180		

Option name		RQ-B			RR-B		
		71	100	125	71	100	125
Central drain plug		KKPJ5F180					
Refrigerant branch piping	Twin	KHRQ22M20TA					
	Triple	-	KHRQ127H		-	KHRQ127H	

Option name		RZQ-B					
		71	100	125	140	200	250
Central drain plug		KKPJ5F180			-		
Central drain pan kit		-	-	-	-	KWC26B280	
Refrigerant branch piping	Twin	KHRQ22M20TA					
	Triple	-	KHRQ127H			KHRQ250H7	
	Double twin	-	-	KHRQ22M20TA (3x)			
Demand adapter kit		KRP58M51			-		

Option name	R(Y)P-B	
	200	250
Refnet	KHRQ22M20TA	
Refnet	KHRQ22M64T	
Refnet	KHRP127HB	

4 VRV

4 - 1 Wall mounted type FXAQ-MA

Option name	FXAQ-MA					
	20	25	32	40	50	63
Drain pump kit	K-KDU572CVE					
Wired remote control	BRC1D52					
Infrared remote control	Heat pump		BRC7E618			
	Cooling only		BRC7E619			
Centralised remote control	DCS302C51					
Unified on/off control	DCS301B51					
Schedule timer	DST301B51					
Wiring adapter for electrical appendices *1 #	KRP2A51					
Wiring adapter for electrical appendices *2 #	KRP4A51					
Installation box for adapter PCB *2 *3	KRP4A93					
Remote sensor	KRCS01-1					
Electrical box with earth terminal (3 blocks)	KJB311A					
Electrical box with earth terminal (2 blocks)	KJB212A					
Noise filter (for electromagnetic interface use only)	KEK26-1A					
External control adapter for outdoor units (installation on indoor unit) #	DTA104A61					

*1 Installation box is necessary for each adapter marked with #.
 *2 Up to 2 adapters can be fixed per installation box.
 *3 Only 1 installation box can be installed per indoor unit.

1
4

4 - 2 Floor standing type FXLQ-MA

Option name	FXLQ-MA					
	20	25	32	40	50	63
Wired remote control	BRC1D52					
Infrared remote control	Heat pump		BRC4C62			
	Cooling only		BRC4C64			
Simplified remote control	BRC2A51					
Remote control for hotel use	BRC3A61					
Centralised remote control	DCS302C51					
Unified on/off control	DCS301B51					
Schedule timer	DST301B51					
Wiring adapter	KRP1B61					
Wiring adapter for electrical appendices	KRP2A51					
Wiring adapter for electrical appendices *1	KRP4A51					
Remote sensor	KRCS01-1					
Electrical box with earth terminal (3 blocks)	KJB311A					
Electrical box with earth terminal (2 blocks)	KJB212A					
Noise filter (for electromagnetic interface use only)	KEK26-1A					
External control adapter for outdoor units (installation on indoor unit)	DTA104A61					

*1 Up to 2 adapters can be fixed per installation box.

4 VRV

4 - 3 Concealed floor standing type FXNQ-MA

1
4

Option name	FXNQ-MA					
	20	25	32	40	50	63
Wired remote control	BRC1D52					
Infrared remote control	Heat pump					
	Cooling only					
Simplified remote control	BRC2A51					
Remote control for hotel use	BRC3A61					
Centralised remote control	DCS302C51					
Unified on/off control	DCS301B51					
Schedule timer	DST301B51					
Wiring adapter	KRP1B61					
Wiring adapter for electrical appendices	KRP2A51					
Wiring adapter for electrical appendices *1	KRP4A51					
Remote sensor	KRCS01-1					
Electrical box with earth terminal (3 blocks)	KJB311A					
Electrical box with earth terminal (2 blocks)	KJB212A					
Noise filter (for electromagnetic interface use only)	KEK26-1A					
External control adapter for outdoor units (installation on indoor unit)	DTA104A61					

*1 Up to 2 adapters can be fixed per installation box.

4 - 4 2-Way blow ceiling mounted cassette FXCQ-M8

Option name	FXCQ-M8							
	20	25	32	40	50	63	80	125
Decoration panel	BYBC32G			BYBC50G		BYBC63G	BYBC125G	
Wired remote control	BRC1D52							
Infrared remote control	Heat pump							
	Cooling only							
Centralised remote control	DCS302C51							
Unified on/off control	DCS301B51							
Schedule timer	DST301B51							
Wiring adapter (hour meter)	EKR1B2							
Wiring adapter for electrical appendices *1 #	KRP2A51							
Wiring adapter for electrical appendices *2 #	KRP4A51							
Remote sensor	KRCS01-1							
Installation box for adapter PCB *1 *2	KRP1B96							
Electrical box with earth terminal (3 blocks)	KJB311A							
Electrical box with earth terminal (2 blocks)	KJB212A							
Noise filter (for electromagnetic interface use only)	KEK26-1A							
External adapter for outdoor unit (installation on indoor unit) #	DTA104A61							

*1 Up to 2 adapters can be fixed for each installation box.
 *2 Only 1 installation box can be installed per indoor unit.
 *3 Installation box is necessary for each adapter marked with #.

4 VRV

4 - 5 4-Way blow ceiling mounted cassette (small) FXZQ-M8

Option name	FXZQ-M8				
	20	25	32	40	50
Decoration panel	BYFQ60B				
Sealing member of air discharge outlet	KDBH44BA60				
Panel spacer	KDBQ44B60				
Fresh air intake kit direct installation type	KDDQ44XA60				
Wired remote control	BRC1D52				
Infrared remote control	Heat pump	BRC7E530			
	Cooling only	BRC7E531			
Centralised remote control	DCS302C51				
Unified on/off control	DCS301B51				
Schedule timer	DST301B51				
Wiring adapter #	KRP1B57				
Wiring adapter for electrical appendices *1 #	KRP2A52				
Wiring adapter for electrical appendices *2 #	KRP4A53				
Remote sensor	KRCS01-1				
Installation box for adapter PCB *2	KRP1BA101				
Electrical box with earth terminal (3 blocks)	KJB311A				
Electrical box with earth terminal (2 blocks)	KJB212A				
Noise filter (for electromagnetic interface use only)	KEK26-1A				
External control adapter for outdoor units (installation on indoor unit) #	DTA104A52				

*1 Up to 2 adapters can be fixed for each installation box.
 *2 Only 1 installation box can be installed per indoor unit.
 *3 Installation box is necessary for each adapter marked with #.

1
4

4 - 6 4-Way blow ceiling mounted cassette FXFQ-M8

Option name	FXYCP-M8								
	20	25	32	40	50	63	80	100	125
Decoration panel	BYC125K								
Fresh air intake kit	Chamber type	without T-shape and fan	KDDP55D160						
		with T-shape	KDD55DA160K						
Air discharge outlet sealing member	KDBHJ55K160								
Panel spacer	KDBP55H160W								
Wired remote control	BRC1D52								
Infrared remote control	Heat pump	BRC7C512							
	Cooling only	BRC7C513							
Centralised remote control	DCS302C51								
Unified on/off control	DCS301B51								
Schedule timer	DST301B51								
Wiring adapter (hour meter) #	EKRP1B2								
Wiring adapter for electrical appendices *1 #	KRP2A52								
Wiring adapter for electrical appendices *2 #	KRP4A53								
Remote sensor	KRCS01-1								
Installation box for adapter PCB	KRP1C98								
Electrical box with earth terminal (3 blocks)	KJB311A								
Electrical box with earth terminal (2 blocks)	KJB212A								
Noise filter (for electromagnetic interface use only)	KEK26-1A								
External control adapter for outdoor units (installation on indoor unit) #	DTA104A52								

*1 Up to 2 adapters can be fixed for each installation box.
 *2 Only 1 installation box can be installed per indoor unit.
 *3 Installation box is necessary for each adapter marked with #.

4 VRV

4 - 7 4-Way blow ceiling suspended cassette FXUQ-MA

1
4

Option name	FXUQ-MA		
	71	100	125
Sealing member of air discharge outlet	KDBH49FA80	KDBHJ49F140	
Decoration panel for air discharge	KDBTJ49F80	KDBTJ49F140	
Vertical flap kit	KDGJ49F80	KDGJ49F140	
Replacement long-life filter	KAF495FA140		
L connection piping kit	KHFP49MA140		
Wired remote control	BRC1D52		
Infrared remote control	Heat pump	BRC7C528	
	Cooling only	BRC7C529	
Centralised remote control	DCS302C51		
Unified on/off control	DCS301B51		
Schedule timer	DST301B51		
Group control adaptor *1	KRP4A53		
Interface adapter for sky air series	DTA102A52		
Installation box for adapter PCB	KRP1B97		
Remote sensor	KRCS01-1		
Connector for forced on, forced off	EKRR00		
Junction box for connection to VRV	BEVQ71MA	BEVQ100MA	BEVQ125MA

*1 Installation box for adapter PCB (KRP1B97) is necessary.

4 - 8 Ceiling mounted cassette FXKQ-MA

Option name	FXKQ-MA			
	25	32	40	63
Decoration panel		BYK45F		BYK71F
Panel spacer		KPBJS2F56		KPBJS2F80
Long life replacement filter		KAFJ521F56		KAFJ521F80
Air discharge blind panel		KDBJ52F56W		KDBJ52F80W
Flexible duct (with shutter)		KFDJ52F56		KFDJ52F80
Wired remote control		BRC1D52		
Infrared remote control	Heat pump	BRC4C61		
	Cooling only	BRC4C63		
Centralised remote control		DCS302C51		
Unified on/off control		DCS301B51		
Schedule timer		DST301B51		
Wiring adapter		KRP1B61		
Wiring adapter for electrical appendices *1		KRP2A61		
Wiring adapter for electrical appendices *2		KRP4A51		
Remote sensor		KRCS01-1		
Electrical box with earth terminal (3 blocks)		KJB311A		
Electrical box with earth terminal (2 blocks)		KJB212A		
Noise filter (for electromagnetic interface use only)		KEK26-1A		
External control adapter for outdoor units (installation on indoor unit)		DTA104A61		

*1 Up to 2 adapters can be fixed for each installation box.
*2 Only 1 installation box can be installed per indoor unit.

4 VRV

4 - 9 Ceiling suspended type FXHQ-MA

Option name	FXHQ-MA		
	32	63	100
Drain pump kit	KDU50M60	KDU50M125	KDU50M125
Replacement long-life filter	Resin net	KAF501DA56	KAF501DA112
L-type piping kit for upward direction	KHFP5M35	KHFP5M63	KHFP5M63
Wired remote control		BRC1D52	
Infrared remote control	Heat pump	BRC7E63	
	Cooling only	BRC7E66	
Centralised remote control		DCS302C51	
Unified on/off control		DCS301B51	
Schedule timer		DST301B51	
Wiring adapter		KRP1B3	
Wiring adapter for electrical appendices *1 #		KRP2A62	
Wiring adapter for electrical appendices *2 #		KRP4A52	
Remote sensor		KRCS01-1	
Installation box for adapter PCB *3		KRP1C93	
Electrical box with earth terminal (3 blocks)		KJB311A	
Electrical box with earth terminal (2 blocks)		KJB212A	
Noise filter (for electromagnetic interface use only)		KEK26-1A	
External control adapter for outdoor units (installation on indoor unit) #		DTA104A62	

*1 Installation box is necessary for each adapter marked with #
 *2 Up to 2 adapters can be fixed for each installation box.
 *3 Only 1 installation box can be installed per indoor unit.

1
4

4 - 10 Concealed ceiling type FXDQ-M8

Option name	FXDQ-M8	
	20	25
Wiring adapter (Hour meter)		EKRP1B2
Wired remote control		BRC1D52
Infrared remote control	Heat pump	BRC4C62
	Cooling only	BRC4C64
Simplified remote control		BRC2A51
Remote control for hotel use		BRC3A61
Centralised remote control		DCS302C51
Unified on/off control		DCS301B51
Schedule timer		DST301B51
Wiring adapter		KRP1B61
Wiring adapter for electrical appendices *1		KRP2A51
Wiring adapter for electrical appendices *2		KRP4A51
Remote sensor		KRCS01-1
Electrical box with earth terminal (3 blocks)		KJB311A
Electrical box with earth terminal (2 blocks)		KJB212A
Noise filter (for electromagnetic interface use only)		KEK26-1A
External control adapter for outdoor units (installation on indoor unit)		DTA104A61

*1 Up to 2 adapters can be fixed for each installation box.
 *2 Only 1 installation box can be installed per indoor unit.

4 VRV

4 - 11 Slim concealed ceiling type FXDQ-P/N

1
4

Option name	FXDQ-P/N					
	20	25	32	40	50	63
Wired remote control	BRC1D52					
Infrared remote control	Heat pump					
	Cooling only					
Simplified remote control	BRC2A51					
Remote control for hotel use	BRC3A61					
Central remote control	DCS302C51					
Unified on/off control	DCS301B51					
Schedule timer	DST301B51					
Wiring adapter for electrical appendices *1	KRP2A53					
Wiring adapter for electrical appendices *2	KRP4A54					
Remote sensor	KRCS01-1					
Installation box for adapter PCB	KRP1BA101					
Electrical box with earth terminal (3 blocks)	KJB212A					
Electrical box with earth terminal (2 blocks)	KJB311A					
Noise filter (for electromagnetic interface use only)	KEK26-1A					
External control adapter for outdoor units (installation on indoor unit)	DTA104A53					

*1 Up to 2 adapters can be fixed for each installation box.
*2 Only 1 installation box can be installed per indoor unit.

4 - 12 Concealed ceiling type FXSQ-M8

Option name	FXSQ-M8								
	20	25	32	40	50	63	80	100	125
Decoration panel	BYBS32D		BYBS45D			BYBS71D		BYBS125D	
Service access panel	KTBJ25K36W		KTBJ25K56W			KTBJ25K80W		KTBJ25K160W	
High efficiency filter 65% *1	KAFJ252L36		KAFJ252L56			KAFJ252L80		KAFJ252L160	
High efficiency filter 90% *1	KAFJ253L36		KAFJ253L56			KAFJ253L80		KAFJ253L160	
Filter chamber from bottom suction	KAJ25L36D		KAJ25L56D			KAJ25L80D		KAJ25L160D	
Filter chamber for rear suction	KAJ25L36B		KAJ25L56B			KAJ25L80B		KAJ25L160B	
Air suction canvas	KSA-25K36		KSA-25K56			KSA-25K80		KSA-25K160	
Air discharge adapter for round duct	KDAJ25K36		KDAJ25K56			KDAJ25K71		KDAJ25K140	
Wired remote control	BRC1D52								
Infrared remote control	Heat pump								
	Cooling only								
Simplified remote control	BRC2A51								
Remote control for hotel use	BRC3A61								
Centralised remote control	DCS302C51								
Unified on/off control	DCS301B51								
Schedule timer	DST301B51								
Wiring adapter for electrical appendices *2	KRP2A51								
Wiring adapter for electrical appendices *3	KRP4A51								
Remote sensor	KRCS01-1								
Electrical box with earth terminal (3 blocks)	KJB311A								
Electrical box with earth terminal (2 blocks)	KJB212A								
Noise filter (for electromagnetic interface use only)	KEK26-1A								
External control adapter for outdoor units (installation on indoor unit)	DTA104A61								
Option PCB for external electric heater, humidifier and/or hour meter *2 *3 *4	EKRP1B2								

*1 If installing a high efficiency filter in the unit, an assembly chamber for either bottom or rear suction is required.
*2 Electrical heater and humidifier are field supply. These parts should not be installed inside the equipment. (Cf. installation manual on EKRP1B2).
*3 If installing an electric heater, an option PCB for external electric heater (EKRP1B2) per indoor unit is required.
*4 An electric heater cannot be used for VRV system cooling only.

4 VRV

4 - 13 Concealed ceiling type FXMQ-MA

Option name	FXMQ-MA							
	40	50	63	80	100	125	200	250
Drain pump kit	KDU30L125						KDU30L250	
Filter chamber	-						KDJ3705L280	
Replacement long life filter	-						KAFJ371L280	
Wired remote control	BRC1D52							
Infrared remote control	Heat pump			BRC4C62				
	Cooling only			BRC4C64				
Simplified remote control	BRC2A51							
Remote control for hotel use	BRC3A61							
Centralised remote control	DCS302C51							
Unified on/off control	DCS301B51							
Schedule timer	DST301B51							
Wiring adapter	KRP1B61							
Wiring adapter for electrical appendices *1	KRP2A61							
Wiring adapter for electrical appendices *2	KRP4A51							
Remote sensor	KRCS01-1							
Electrical box with earth terminal (3 blocks)	KJB311A							
Electrical box with earth terminal (2 blocks)	KJB212A							
Noise filter (for electromagnetic interface use only)	KEK26-1A							
External control adapter for outdoor units (installation on indoor unit)	DTA104A61							

*1 Up to 2 adapters can be fixed for each installation box.
*2 Only 1 installation box can be installed per indoor unit.

1
4

4 - 14 Outdoor air processing unit FXMQ-MF

Option name	FXMQ-MF		
	125	200	250
Drain pump kit	KDU30L250		
High efficiency filter	65%	KAFJ372L140	KAFJ372L280
	90%	KAFJ373L140	KAFJ373L280
Filter chamber	KDJ3705L140	KDJ3705L280	
Long life replacement filter	KAFJ371L140	KAFJ371L280	
Remote control	Wired	BRC1A62	
Adapter for wiring	KRP1B61		
Wiring adapter for electrical appendices (1)	KRP2A61		
Wiring adapter for electrical appendices (2)	KRP4A51		
Central remote control	DCS302C61		
Electrical box with earth terminal (3 blocks)	KJB311A		
Unified on/off controller	DCS301B61		
Electrical box with earth terminal (2 blocks)	KJB212A		
Noise filter (for electromagnetic interface use only)	KEK26-1A		
Schedule timer	DST301B51		
External control adapter for outdoor unit (Must be installed on indoor units)	DTA104A61		

4 VRV

4 - 15 Outdoor units

1
4

Option name	RX(Y)Q-P			RXYQ-P
	5	8,10	12,14,16,18	20-54
Cool/heat selector	KRC19-26			
Fixing box	KJB111A			
Refnet header	KHRQ22M29H	KHRQ22M29H	KHRQ22M29H	KHRQ22M29H
			KHRQ22M64H	KHRQ22M64H
				KHRQ22M75H
Refnet joint	KHRQ22M20T(A)	KHRQ22M20T(A)	KHRQ22M20T(A)	KHRQ22M20T(A)
		KHRQ22M29T9	KHRQ22M29T9	KHRQ22M29T9
			KHRQ22M64T	KHRQ22M64T
				KHRQ22M75T
Outdoor unit multi connection kit for 2 outdoor units			BHFQ22P1007	
Outdoor unit multi connection kit for 3 outdoor units			BHFQ22P1517	
Central drain kit	KWC26B160	KWC26B280	KWC26B450	See note 2

*1 All options are kits.
*2 Central drain pan kit shall be combined based on the outdoor multi connection table.

Option name	RXYSQ-P		
	4	5	6
Cool/heat selector	KRC19-26		
Fixing box	KJB111A		
Refnet header	KHRQ22M29H		
Refnet joint	KHRQ22M20T(A)		
Central drain pan kit	KCPJ5F180		

*1 All options are kits.

Option name	REYQ-M		
	8-10	12-14-16	18-48
Refnet header	KHRQ23M29H	KHRQ23M29H	KHRQ23M29H
		KHRQ23M64H	KHRQ23M64H
			KHRQ23M75H
Refnet joint	KHRQ23M20T	KHRQ23M20T	KHRQ23M20T
	KHRQ23M29T	KHRQ23M29T	KHRQ23M29T
		KHRQ23M64T	KHRQ23M64T
			KHRQ23M75T
Outdoor multi connection kit for 2 outdoor units	-	-	BHFQ23M90
Outdoor multi connection kit for 3 outdoor units	-	-	BHFQ23M135
Central drain pan kit	KWC26B280	KWC26B450	See note 2

*1 All options are kits.
*2 Central drain pan kit shall be combined based on the outdoor multi connection table.

4 VRV

1
4

Option name		RWEYQ-M		
		10	20	30
Cool/heat selector		KRC19-26		
Fixing box		KJB111A		
Refnet header	Heat recovery	KHRQ23M29H	KHRQ23M29H, KHRQ23M64H, KHRQ23M75H	
	Heat pump	KHRQ22M29H	KHRQ22M29H, KHRQ22M64H, KHRQ22M75H	
Refnet joint	Heat recovery	KHRQ23M20T, KHRQ23M29T	KHRQ23M20T, KHRQ23M29T, KHRQ23M64T, KHRQ23M75T	
	Heat pump	KHRQ22M20T, KHRQ22M29T9	KHRQ22M20T, KHRQ22M29T9, KHRQ22M64T, KHRQ22M75T	
Outdoor unit multi connection piping kit	Heat recovery	-	BHFP26MA56	BHFP26MA84
	Heat pump	-	BHFP22MA56	BHFP22MA84
Water piping strainer		BWU26A15 (1.47MPa); BWU26A20 (1.96MPa)		

Option name		RMXS-EV		
		112	140	160
Drain plug		KKPJ5F180		
Refnet joint		KHRQ22M20TA		
Branch provider (2 rooms)		BPMKS967A2		
Branch provider (3 rooms)		BPMKS967A3		

*1 All options are kits.

Option name		BSVQ-M		
		100	160	250
Cool/Heat selector		KRC19-26		
Fixing box		KJB111A		

5 NETWORK SOLUTIONS

5 - 1 DS net*

1
5

Option name	Reference	Comments
D-net	DTA113B51	4 units can be connected per adapter, 40 units when 40 adapters are connected
Software	DPC001B1-B51	Monitoring panel software

* Only applicable for VRV

5 - 2 Intelligent touch Controller*

Option name	Reference	Comments
Intelligent touch Controller	DCS601C51	2x64 units can be connected
Software	DCS002C51	Power Proportional Distribution (PPD) software
	DCS004A51	E-mail / Web software
Installation box	KJB411A	For wall mounted installation
Touch-Pen	I264009	Spare part n° of Touch-Pen for Intelligent touch Controller
Interface adapters	KRP928A2S	For connection to Split units
	DTA102A52	For connection to R-22 / R-407C Sky Air units
	DTA112B51	For connection to R-410A Sky Air units
Digital input	DEC101A51	Input contacts: 16 points
Digital input/output	DEC102A51	Input contacts: 8 points; output contacts: 4 points

* Only applicable for VRV

5 - 3 Intelligent Manager*

Option name	Reference	Comments
Intelligent Processing unit	DAM602B51	256 indoor units per IPU
	DAM602B52	128 indoor units per IPU
Interface adapters	KRP928A2S	For connection to Split units
	DTA102A52	For connection to R-407C / R-22 Sky Air units
	DTA112B51	For connection to R-410A Sky Air units
Software	DAM002A51	Power Proportional Distribution
	DAM003A51	ECO
	DAM004A51	Web-Access
DIII Ai	DAM101A51	Outdoor temperature sensor
Digital input	DEC101A51	Input contacts: 16 points
Digital input/output	DEC102A51	Input contacts: 8 points; output contacts: 4 points

* Only applicable for VRV

5 - 4 DMS-IF

Option name	Reference	Comments
LonWorks* networks compatible Gateway	DMS504B51	Up to 64 units can be connected per DMS-IF
Interface adapters	KRP928A2S	For connection to Split units
	DTA102A52	For connection to R-407C / R-22 Sky Air units
	DTA112B51	For connection to R-410A Sky Air units

5 NETWORK SOLUTIONS

5 - 5 BACnet Gateway

Option name	Reference	Comments
BACnet Gateway	DM5502A51	64 units per Gateway
DIII board	DAM411B51	Extension of 3 x DIII lines (3 x 64) indoor units
Digital input/output	DAM412B51	For forced shutdown
Interface adapters	KRP928A2S	For connection to Split units
	DTA102A52	For connection to R-407C / R-22 Sky Air units
	DTA112B51	For connection to R-410A Sky Air units

1
5

5 - 6 BMS*

Option name	Reference	Comments	
Contact / analog signal	Wiring adapter for electrical appendices	KRP2A51 KRP2A52	Simultaneously controls air conditioning control computer and up to 64 groups of indoor units
	Wiring adapter for electrical appendices		
External control adapter for outdoor unit	DTA104A51	DTA104A52	Cooling/heating mode change over, demand control and low noise control are available between the plural outdoor units
	DTA104A52		
DIII-net expander adapter	DTA109A51	A maximum of 10 outdoors or 128 indoors can be connected to 1 DTA109A51 A maximum of 8 DTA109A51 can be connected to DIII-net	
Mounting kit	KRP4A92	For easy installation of the DTA109A51	

* Only applicable for VRV

6 HRV

6 - 1 VKM-GA

1
6

Option name		VKM-GA										
		50			80			100				
Controlling device	Remote control	BRC1D52/BRC301B61										
	Centralised control systems	Centralised remote control	DCS302C51									
		Unified ON/OFF control	DCS301B51									
		Schedule timer	DST301B51									
	PC Board Adapter	Wiring adapter for electrical appendices	KRP2A61									
		For humidifier running ON signal output	KRP50-2									
		Installation box for adapter PCB	KRP50-2A90 (Mounted electric component assy of HRV)									
		For heater control kit	BRP4A50									
	For wiring	VRV indoor unit	FXCQ-M	FXFQ-M	FXKQ-M	FXSQ-M	FXMQ-M	FXHQ-M	FXAQ-M	FXDQ-N	FXLQ-M FXNQ-M	FXZQ-M
			KRP1B61★	KRP1B59★	KRP1B61			KRP1B3	—	—	KRP1B61	KRP1B57★
Installation box for adapter PCB		Notes 2, 3 KRP1B96	Notes 2, 3 KRP1D98	—	—	—	Note 3 KRP1C93	Notes 2, 3 KRP4A93	Notes 4, 6 KRP1BA101	—	Notes 4, 6 KRP1BA101	

*1 Installation box is necessary for each adapter marked★.

*2 Up to 2 adapters can be fixed for each installation box.

*3 Only one installation box can be installed for each indoor unit.

*4 Up to 2 installation boxes can be installed for each indoor unit.

*5 Installation box is necessary for each adapter.

*6 Necessary when operating HRV (VKM) independently. When operating interlocked with other air conditioners, use the air conditioner remote control.

Option name		VKM-GA	
		50	80
Additional function	Silencer	KDDM24B100	
	Nominal pipe diameter (mm)	ø250 mm	
	High efficiency filter	KAF241G80M	KAF241G100M
Air filter for replacement *1		KAF242G80M	KAF242G100M

*1 Including 2 sheets per unit.

6 HRV

6 - 2 VAM-FA

Option name	VAM-FA				
	150	250	350	500	650
Remote Control	BRC301B61				
Wiring adapter for Humidifier	KRP50-2				
Installation box for adapter PCB	KRP50-2A90 (Mounted electric component assembly of HRV)				
Wiring adapter for electrical appendices	KRP2A61 (For general) KRP2A51 (For EC Market)				
Central Remote Control	DCS302C51 (For EC Market)				
Schedule Timer	DST301B51 (For EC Market)				
Unified ON / OFF control	DCS301B61 (For general) DCS301B51 (For EC Market)				
High efficiency filter	YAFM323F15	YAFM323F25	YAFM323F35	YAFM323F50	YAFM323F65
Heater control kit	BRP4A50				
Adapter for discharge	-	-	-	KDAJ25K36	KDAJ25K56

Option name	VAM-FA				
	800	1000	1500	2000	
Remote Control	BRC301B61				
Wired Remote Control	BRC1D52				
Central Remote Control	DCS302C51 (For EC Market)				
Unified ON / OFF control	DCS301B61 (For general) DCS301B51 (For EC Market)				
Schedule Timer	DST301B51 (For EC Market)				
Wiring adapter for electrical appendices	KRP2A61 (For general) KRP2A51 (For EC Market)				
Wiring adapter for Humidifier	KRP50-2				
Installation box for adapter PCB	KRP50-2A90 (Mounted electric component assembly of HRV)				
Heater Control Kit	BRP4A50				
High efficiency filter	YAFM323F65	YAFM323F100	YAFM323F65 × 2	YAFM323F100 × 2	
Duct adapter	Model name	-	-	YDFA25A1	YDFA25A1
	Nominal pipe diameter (mm)	-	-	φ 250	φ 250
Adapter for discharge	KDAJ25K56	KDAJ25K56	-	-	

Interlock adapter for VRV

Indoor Unit	FXYCP-K	FXK-L	FXYFP-K	FXYSP-K	FXH-L	FXA-L/FXYAP-L	FXL-L/FXN-L	FXM-L
Adapter for wiring	KRP1B61 *	KRP1B61	KRP1B2 *	KRP1B61		KRP1B3	KRP1B61	
Installation box for adapter PCB **	KRP1B96 Note 2, 3	-	KRP1C98 Note 4	-	-	KRP1B93 Note 3	-	-

Notes:

1. Installation box ** is required for each adapter marked *
2. Up to 2 adapters can be fixed for each installation.
3. Only one installation box can be installed for each indoor unit.
4. Up to 2 adapters can be fixed for each indoor unit.
5. Flexible duct size *** is for the duct from HRV unit to branch duct (or air outlet).

Drawings **2**

BEVQ-MA - Junction box

Technical Specifications				BEVQ71MA	BEVQ100MA	BEVQ125MA
Power input (Nominal)	Cooling	kW		0.189	0.298	0.298
	Heating	kW		0.169	0.278	0.278
Casing	Material Galvanised steel plate					
Dimensions	Unit	Height	mm	100	100	100
		Width	mm	350	350	350
		Depth	mm	225	225	225
Sound absorbing thermal insulation material				Flame and heat resistant foamed polyetherene		
Weight	Machine Weight	kg		3.0	3.0	3.5
Indoor Units	Liquid (OD)	Type		Flare connection		
		Diameter	mm	9.5	9.5	9.5
	Gas	Type		Flare connection		
		Diameter	mm	15.9	15.9	15.9
Outdoor Unit	Liquid (OD)	Type		Flare connection		
		Diameter	mm	9.5	9.5	9.5
	Suction gas (OD)	Type		Flare connection		
		Diameter	mm	15.9	15.9	15.9
Standard Accessories	Item		Installation manual			
	Quantity		1	1	1	
	Item		Gas piping connections			
	Quantity		1	1	1	
	Item		Insulation for fitting			
	Quantity		3	3	3	
	Item		Sealing material			
	Quantity		3	3	3	
	Item		Clamps			
	Quantity		9	9	9	

Electrical Specifications				BEVQ71MA	BEVQ100MA	BEVQ125MA
Power Supply	Name		VE			
	Phase		1~			
	Frequency	Hz	50/60			
	Voltage	V	220-240			
Voltage range	Minimum	V	-10%			
	Maximum	V	+10%			
Total circuit	Minimum circuit amps (MCA)	A	0.8	1.3	1.3	
	Maximum fuse amps (MFA)	A	15	15	15	

NOTES

- *1 Voltage range: units are suitable for use on electrical systems where voltage supplied to unit terminals is not below or above listed range limits.
- *2 Maximum allowable voltage range variation between phases is 2%.
 - MCA/MFA
 - MCA=1.25 X FLA
- *3 MFA is smaller than or equal to 4 x FLA
- *4 Next lower standard fuse rating minimum 15A
- *5 Select wire size based on MCA
- *6 Instead of a fuse, use a circuit breaker

BEVQ-MA - Junction box

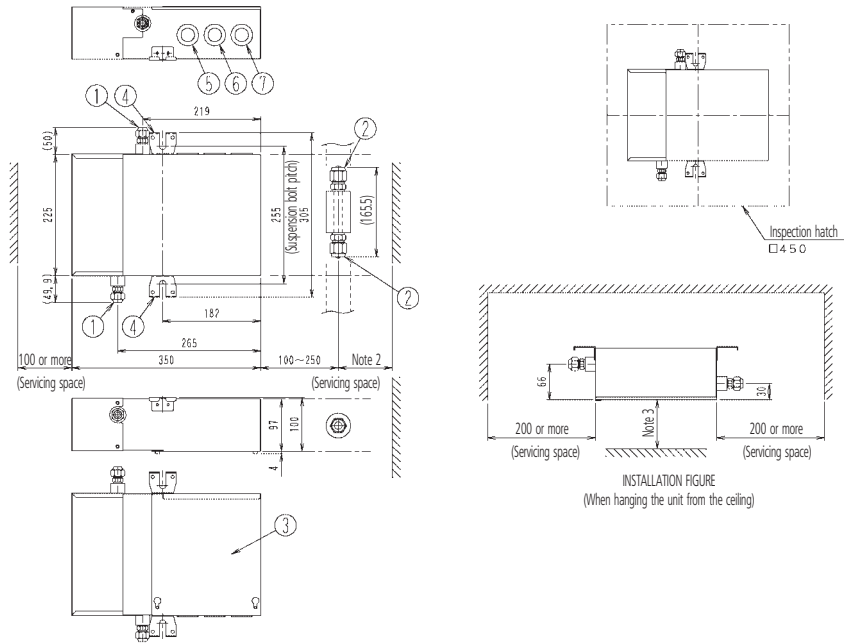

Nr.	Name	Description
1	Liquid pipe connection port	ø 9.5 mm Flare connection
2	Gas pipe connection port	ø 15.9 mm Flare connection
3	Electric parts box	
4	Suspension bolt	
5	Wire connection port (Indoor unit connection)	
6	Wire connection port (Power supply • Ground)	
7	Wire connection port (Transmission (VRV) • Gas pipe thermistor)	

NOTES

- 1 Be sure to install wire connection port to be sure to become downward.
- 2 Be sure to secure the space which can be the tightening work of the flare nut.
- 3 Be sure to secure the space of 400 mm or more when you cannot install the inspection hatch right under the unit.

BEVQ-MA - Junction box

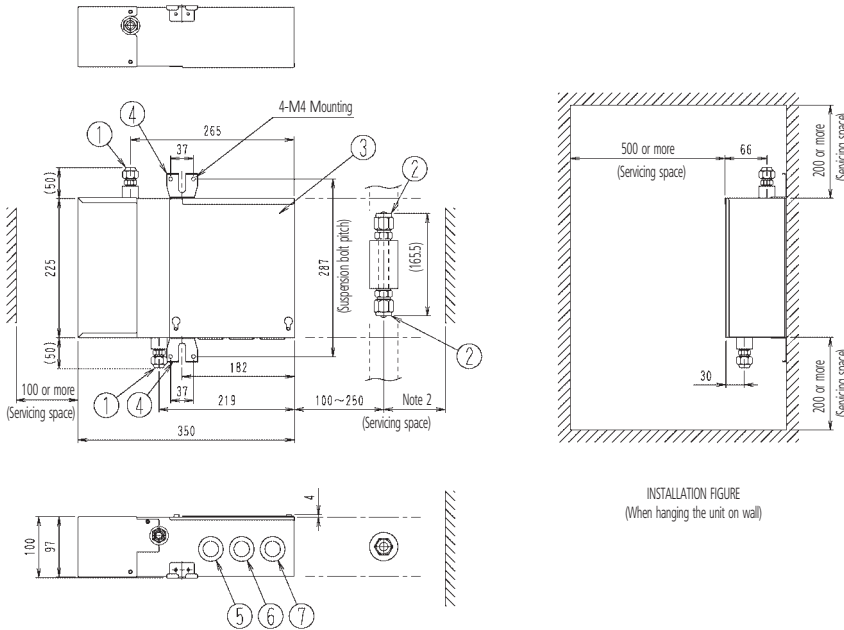

Nr.	Name	Description
1	Liquid pipe connection port	ø 9.5 mm Flare connection
2	Gas pipe connection port	ø 15.9 mm Flare connection
3	Electric parts box	
4	Suspension bolt	
5	Wire connection port (Indoor unit connection)	
6	Wire connection port (Power supply • Ground)	
7	Wire connection port (Transmission (VRV) • Gas pipe thermistor)	

NOTES

- 1 Be sure to install wire connection port to be sure to become downward.
- 2 Be sure to secure the space which can be the tightening work of the flare nut.

BHFQ22P1007 • BHFQ22P1517

		Reducers				Insulation tube	
		for gas pipe		for liquid pipe		for gas pipe	for liquid pipe
Gas-side junction							
Liquid-side junction							

BHFQ23M90-135 - Outdoor unit multi connection piping kit
VRVII heat recovery

	Reducers / Expanders			Liquid side junction	Discharge gas side junction	Suction gas side junction	Joint for oil pipe
	For suction gas pipe	For discharge gas pipe	For liquid pipe				
BHFQ23M90							
BHFQ23M135							

BPMKS967A2, BPMKS967A3 - Branch provider

Model				BPMKS967A2	BPMKS967A3	
				For 2 rooms	For 3 rooms	
Refrigerant type				R410A		
Power supply				~ 50Hz 230V		
Casing color				Painting less		
Power consumption			W	10	10	
Running current			A	0.05	0.05	
Piping connection (brazing)	Liquid	Outdoor unit side	mm	I. D. ø 9.5 x 1		
		Indoor unit side	mm	I. D. ø 6.4 x 2	I. D. ø 6.4 x 3	
	Gas	Outdoor unit side	mm	I. D. ø 19.1 x 1		
		Indoor unit side	mm	I. D. ø 15.9 x 2	I. D. ø 15.9 x 3	
	Drain			mm	Drain processingless	
	Heat insulation				Both liquid and gas pipes	
No. of wiring connection				Power supply	3 (included earth wiring)	
				Between indoor and BP unit	4 (included earth wiring)	
				Between outdoor and BP unit	2 (for DIII transmission)	
Connectable indoor unit type				20 Class ~ 71 class		
Min. combination			kW	2.0		
Max. combination			kW	14.2	20.8	
Dimension (H x W x D) (Total width)* It includes auxiliary piping			mm	180 x 294 (650)* x 350		
Weight			Kg	7.5	8	
Package dimension (H x W x D)			mm	257 x 738 x 427		
Gross weight			Kg	11	12	
Accessories	Installation manual			Pc	1	
	Reducer	For outdoor unit side	Liquid	Pc	1 (for I. D. ø 6.4)	
			Gas	Pc	1 (for I. D. ø 12.7)	
			Gas	Pc	1 (for I. D. ø 15.9, 19.1)	
		For indoor unit side	Liquid	Pc	2 (for I. D. ø 12.7, 9.5)	3 (for I. D. ø 12.7, 9.5)
			Gas	Pc	1 (for I. D. ø 9.5)	
	Hanger metal			Pc	4	
	Screws			Pc	8 (M4 x 8)	
	Head insulation (2 pc. is 1 set)				3 Set	4 Set
	Binding band			Pc	2	
Product country display				No display		

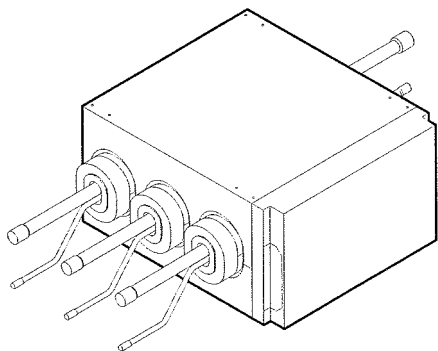

BRC1D52 - Wired remote control

(Unit: mm)

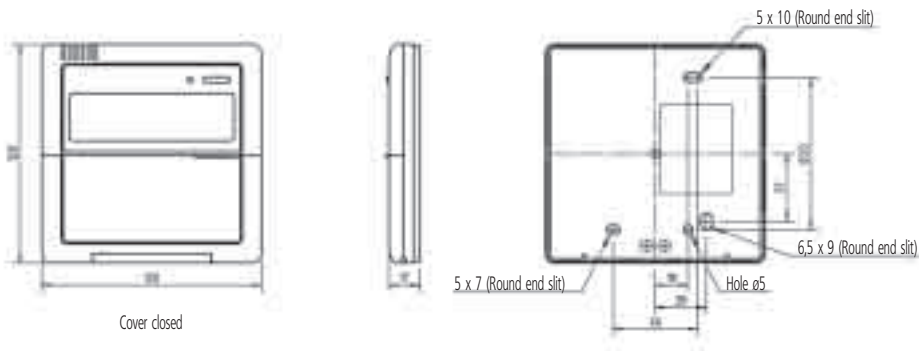

Cover closed



Cover open



BRC1D52

- Limit operation (min./max.): room temperature is controlled within adjustable upper and lower limits. Limit operation can be activated manually or by schedule timer
- Real time clock: indicates real time and day
- Schedule timer:
 - It is possible to programme a weekly schedule timer
 - It is possible to programme the remote control for each day of the week. Five day actions can be set as follows:
 - set point: unit is switched ON and normal operation is maintained
 - OFF: unit is switched OFF
 - limits: unit is switched ON and min./max. control (cf.limit operation for more details)
- Home leave (frost protection): during absence, the indoor temperature can be maintained at a certain level. This function can also switch the unit ON/OFF
- Different levels of disabled buttons can be selected as follows:
 - level 1: all buttons are accessible
 - level 2: all buttons are disabled except for:
 - ON/OFF
 - set temperature up/down
 - fan speed
 - cooling/heating mode
 - enable/disable schedule timer
 - air flow direction adjustment button
 - Level 3: all buttons are disabled except for:
 - ON/OFF
 - set temperature up/down
 - fan speed
- User friendly HRV function, thanks to the introduction of a button for ventilation mode and fan speed
- Constantly monitoring of the system for malfunctions in a total of 80 components
- Immediate display of fault location and condition
- Reduction of maintenance time and costs

Operation buttons:

- ON / OFF
- Timer mode start / stop
- Timer on / off
- Programmed time
- Temperature setting
- Air flow direction adjustment
- Operating mode selection
- Fan speed control
- Filter sign reset
- Inspection test / operation

Display

- Operating mode
- Heat Recovery Ventilation (HRV) in operation
- Cool / heat changeover control
- Centralised control indication
- Group control indication
- Set temperature
- Air flow direction
- Programmed time
- Inspection test / operation
- Fan speed
- Clean air filter
- Defrost / hot start
- Malfunction



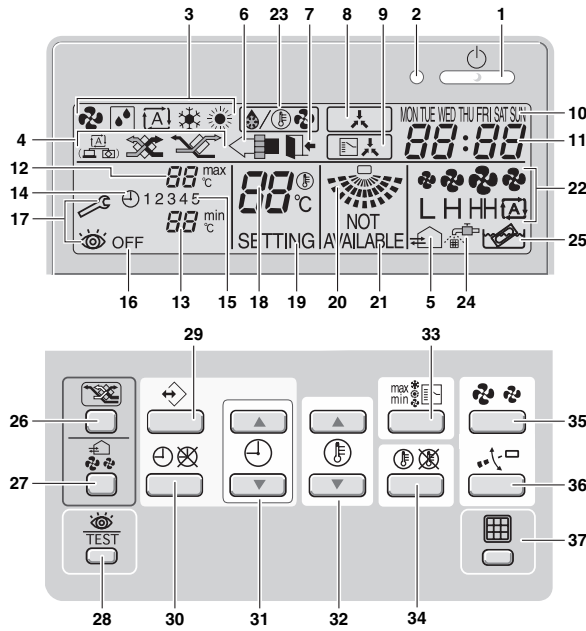





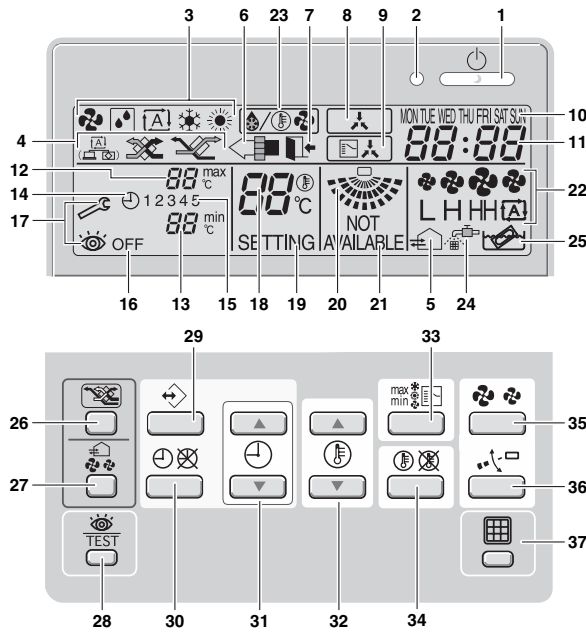



BRC1D52 -Functions



1	ON/OFF BUTTON ' '	13	MINIMUM SET TEMPERATURE ' 88°min '				
	Press the ON/OFF button to start or stop the system.		The minimum set temperature indicates the minimum set temperature when in limit operation.				
2	OPERATION LAMP ' '	14	SCHEDULE TIMER ICON ' '				
	The operation lamp lights up during operation or blinks if a malfunction occurs.		This icon indicates that the schedule timer is enabled.				
3	OPERATION MODE ICON ' '	15	ACTION ICONS ' 1 2 3 4 5 '				
	These icons indicate the current operation mode (FAN, DRY, AUTOMATIC, COOLING, HEATING).		These icons indicate the actions for each day of the schedule timer.				
4	VENTILATION MODE ICON ' '	16	OFF ICON ' OFF '				
	These icons indicate the current ventilation mode (HRV only) (AUTOMATIC, HEAT EXCHANGE, BYPASS).		This icon indicates that the OFF action is selected when programming the schedule timer.				
5	VENTILATION ICON ' '	17	INSPECTION REQUIRED ' ' and ' '				
	The ventilation icon appears when the ventilation is adjusted with the ventilation amount button (HRV only). Simultaneously, the ventilation amount is indicated by the fan speed icon (see 22).		These icons indicate that inspection is required. Consult your installer.				
6	AIR CLEANING ICON ' '	18	SET TEMPERATURE DISPLAY ' 27.8° '				
	This icon indicates that the air cleaning unit (option) is operational.		This indicates the current set temperature of the installation (not shown in LIMIT operation or in FAN or DRY mode).				
7	LEAVE HOME ICON ' '	19	SETTING ' SETTING '				
	The leave home icon shows the status of the leave home function.		Not used, for service purposes only.				
	<table border="1"> <tr> <td>ON</td> <td>Leave home is enabled</td> </tr> <tr> <td>FLASHING</td> <td>Leave home is active</td> </tr> <tr> <td>OFF</td> <td>Leave home is disabled</td> </tr> </table>		ON	Leave home is enabled	FLASHING	Leave home is active	OFF
ON	Leave home is enabled						
FLASHING	Leave home is active						
OFF	Leave home is disabled						
8	EXTERNAL CONTROL ICON ' '	20	NOT AVAILABLE ' NOT AVAILABLE '				
	This icon indicates that another controller with higher priority is controlling or disabling your installation.		This is displayed whenever a non-installed option is addressed or a function is not available.				
9	CHANGE-OVER UNDER CENTRALISED CONTROL ICON ' '	21	FAN SPEED ICON ' '				
	This icon indicates that the change-over of the installation is under centralised control assigned to another indoor unit or optional cool/heat selector connected to the outdoor unit (= master remote controller).		This icon indicates the set fan speed.				
10	DAY OF THE WEEK INDICATOR ' MON TUE WED THU FRI SAT SUN '	22	DEFROST/HOTSTART MODE ICON ' '				
	The day of the week indicator shows the current week day (or the set day when reading or programming the schedule timer).		This icon indicates that the defrost/hotstart mode is active.				
11	CLOCK DISPLAY ' $88:88$ '	23	AIR FILTER CLEANING TIME ICON ' '				
	The clock display indicates the current time (or the action time when reading or programming the schedule timer).		This icon indicates the air filter must be cleaned. Refer to the manual of the indoor unit.				
12	MAXIMUM SET TEMPERATURE ' 88°max '	24	ELEMENT CLEANING TIME ICON ' '				
	The maximum set temperature indicates the maximum set temperature when in limit operation.		This icon indicates the element must be cleaned (HRV only).				
13	MINIMUM SET TEMPERATURE ' 88°min '	25	VENTILATION MODE BUTTON ' '				
			The minimum set temperature indicates the minimum set temperature when in limit operation.	The ventilation mode button operates the HRV; refer to the HRV manual for more details.			
14	SCHEDULE TIMER ICON ' '	26	TEST ' TEST '				
				This icon indicates that the schedule timer is enabled.			
15	ACTION ICONS ' 1 2 3 4 5 '	27	TEST ' TEST '				
				These icons indicate the actions for each day of the schedule timer.			
16	OFF ICON ' OFF '	28	TEST ' TEST '				
				This icon indicates that the OFF action is selected when programming the schedule timer.			
17	INSPECTION REQUIRED ' ' and ' '	29	TEST ' TEST '				
				These icons indicate that inspection is required. Consult your installer.			
18	SET TEMPERATURE DISPLAY ' 27.8° '	30	TEST ' TEST '				
				This indicates the current set temperature of the installation (not shown in LIMIT operation or in FAN or DRY mode).			
19	SETTING ' SETTING '	31	TEST ' TEST '				
				Not used, for service purposes only.			
20	AIR FLOW DIRECTION ICON ' '	32	TEST ' TEST '				
				This icon indicates the air flow direction (only for installations with motorised air flow flaps).			
21	NOT AVAILABLE ' NOT AVAILABLE '	33	TEST ' TEST '				
				This is displayed whenever a non-installed option is addressed or a function is not available.			
22	FAN SPEED ICON ' '	34	TEST ' TEST '				
				This icon indicates the set fan speed.			
23	DEFROST/HOTSTART MODE ICON ' '	35	TEST ' TEST '				
				This icon indicates that the defrost/hotstart mode is active.			
24	AIR FILTER CLEANING TIME ICON ' '	36	TEST ' TEST '				
				This icon indicates the air filter must be cleaned. Refer to the manual of the indoor unit.			
25	ELEMENT CLEANING TIME ICON ' '	37	TEST ' TEST '				
				This icon indicates the element must be cleaned (HRV only).			
26	VENTILATION MODE BUTTON ' '	37	TEST ' TEST '				
				The ventilation mode button operates the HRV; refer to the HRV manual for more details.			

BRC1D52 -Functions



27	VENTILATION AMOUNT BUTTON '  '	33	OPERATION CHANGE/MIN-MAX BUTTON '  '
	This button sets the ventilation amount; refer to the HRV manual for more details.		This button is a multi-purpose button. Depending on the previous manipulations of the user, it can have following functions:
28	INSPECTION/TEST OPERATION BUTTON '  TEST '	34	1 select the operation mode of the installation (FAN, DRY, AUTOMATIC, COOLING, HEATING)
	Not used, for service purposes only.		2 toggle between minimum temperature and maximum temperature when in limit operation
29	PROGRAMMING BUTTON '  '	35	SETPOINT/LIMIT BUTTON '  '
	This button is a multi-purpose button. Depending on the previous manipulations of the user, the programming button can have various functions.		This button toggles between setpoint, limit operation or 'OFF' (programming mode only).
30	SCHEDULE TIMER BUTTON '  '	36	FAN SPEED BUTTON '  '
	This button enables or disables the schedule timer.		This button toggles between L (Low), H (High), HH (very High),  (Automatic).
31	TIME ADJUST BUTTON '  '	37	AIR FLOW DIRECTION ADJUST BUTTON '  '
	These buttons are used to adjust the clock or, when in programming mode, to adjust the programmed action time. Both buttons have an auto-repeat function.		This button enables to adjust the air flow direction.
32	TEMPERATURE ADJUST BUTTON '  '	37	AIR FILTER CLEANING TIME ICON RESET BUTTON '  '
	These buttons are used to adjust the current setpoint or, when in programming mode, to adjust the programmed setpoint temperature (step = 1°C). Both buttons are also used to adjust the day of the week.		This button is used to reset the air filter cleaning time icon.

BRC2A51 - Simplified remote control

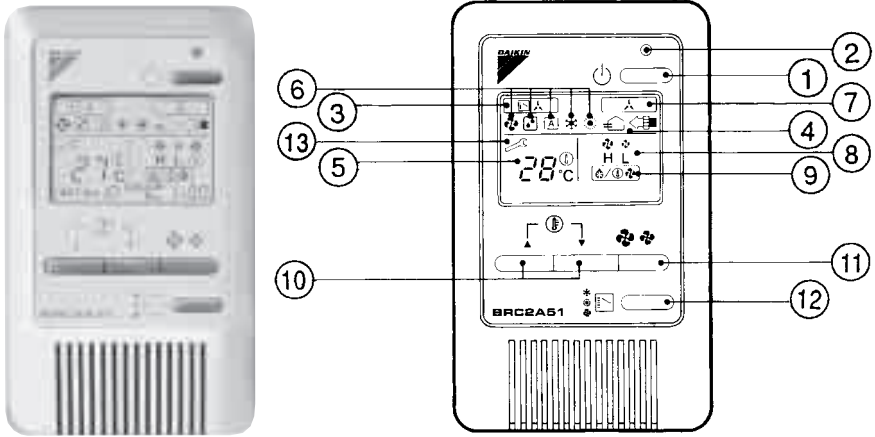

Features

Simplified remote control - BRC2A51

- simple, compact and easy to operate unit
- suitable for use in hotel bedrooms

Operation buttons:

- ON / OFF
- Operation mode selection
- Fan speed control
- Temperature setting

Display

- Cool / heat changeover control
- Heat Recovery Ventilation (HRV) in operation
- Set temperature
- Operating mode
- Centralised control indication
- Fan speed
- Defrost / hot start
- Malfunction adjustment
- Operating mode selection
- Fan speed control
- Filter sign reset
- Inspection test / operation

1	ON/OFF BUTTON Press the button and the system will start. Press the button again and the system will stop.	8	DISPLAY ' ' (FAN SPEED) The display shows the fan speed: "HIGH" or "LOW".
2	OPERATION LAMP (RED) The lamp lights up during operation and blinks in case of stop due to malfunction.	9	DISPLAY ' ' (DEFROST/HOT START) Indicates that defrost or hot start (during which the fan is stopped till the temperature of air supply rises enough at the start of a heating run) is in progress.
3	DISPLAY ' ' (CHANGEOVER UNDER CONTROL) It is impossible to changeover heat/cool with the remote controller when it shows this display. (As for details, see "SETTINGS OF MASTER REMOTE CONTROL" in the operation manual attached to the indoor unit).	10	TEMPERATURE SETTING BUTTON Use this button for SETTING TEMPERATURE of the thermostat. ▲; Each press raises the set temperature by 1°C. ▼; Each press lowers the set temperature by 1°C. The variable temperature range is 16°C tot 32°C.
4	DISPLAY " " " " "OPTION" (VENTILATION / AIR CLEANING) This display shows that the total heat exchange unit and the air cleaning unit are in operation. (These are optional accessories).	11	FAN SPEED CONTROL BUTTON Press this button to select the fan speed, HIGH or LOW, of your choice.
5	DISPLAY ' ' (SET TEMPERATURE) This display shows the set temperature. Only given during a cooling or heating operation.	12	OPERATION MODE SELECTOR BUTTON Press this button to select OPERATION MODE.
6	DISPLAY ' ' (OPERATION MODE) This display shows the current OPERATION MODE. ' ' is not available with outdoor units specially designed for cooling only. ' ' is reserved only for outdoor units capable of heat recovery.	13	DISPLAY ' ' (MALFUNCTION) Indicates malfunction and blinks if the unit stops operating due to the malfunction. (As for details, see "TROUBLE SHOOTING" in the operation manual attached to the indoor unit.)
7	DISPLAY ' ' (UNDER CENTRALIZED CONTROL) When this display shows, the system is UNDER CENTRALIZED CONTROL. (This is not a standard specification)		

NOTE

- 1 Please note that the display shows all indications for the purpose of explanation only. This is contrary to actual running situations.

BRC301B61 - Remote control (Heat recovery ventilation)

Remote control mounting instructions

1. Remove the upper part of remote control.

Insert minus screwdriver into the slots in the lower part of remote controller (2 places), and remove the upper part of remote control.

The PC board is mounted in the upper part of remote controller. Be careful not to damage the board with the minus screwdriver.

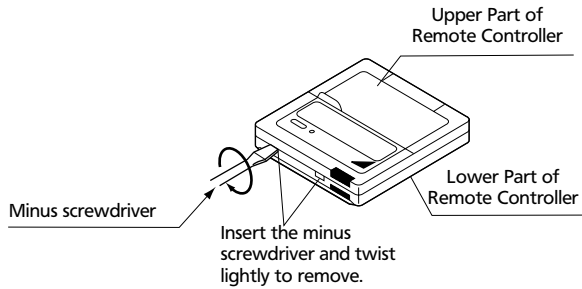

2. Fasten the remote control.

- ① For exposed mounting, fasten with the included wood screws (2).
- ② For flush-mounting, fasten with the included machine screws (2).

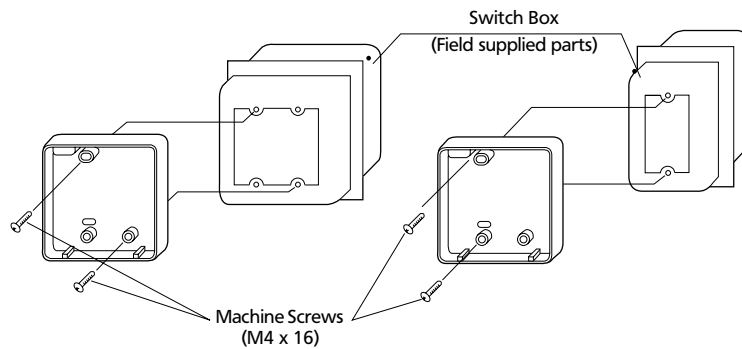
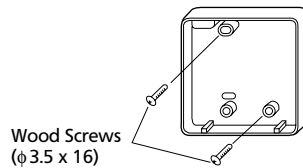

For the field supplied switch box, use optional accessories KJB111A or KJB211.

NOTE

Choose the flattest place possible for the mounting surface. Be careful not to damage the shape of the lower part of remote controller by over-tightening the mounting screws.

BRC301B61 - Remote control (Heat recovery ventilation)

3. Wire the HRV unit.

Connect the terminals on the upper part of the remote controller (P1, P2) and the terminals of the HRV unit (P1, P2).
(P1 and P2 do not have polarity.)

NOTE
When wiring, run the wiring away from the power supply wiring in order to avoid receiving electric noise (external noise).

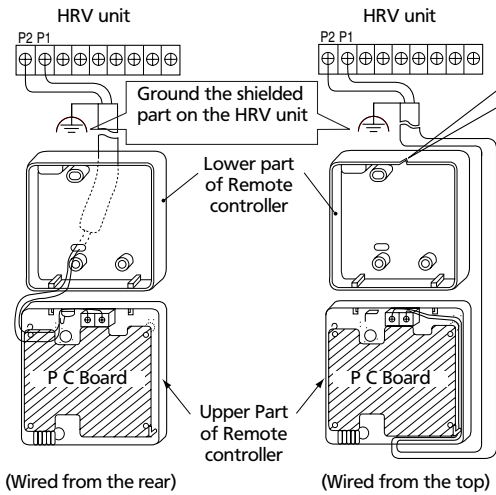

Notch the part for the wiring to pass through with nippers, etc.

Wiring Specifications

Wiring Type	Shield Wire (2 wire) (See NOTE 3)
Size	0.75 - 1.25 mm ²

NOTE:

1. Peel the shield and sheath for the part that is to pass through the inside of the remote controller case, as shown in the figure below.
2. Treat the terminal for the wire to be connected to the remote controller so the shielded part doesn't touch any other part.
3. Sheathed wire may be used for transmission wirings, but they do not comply with EMC (Electromagnetic Compatibility) (European Directive). When using sheathed wire, EMC must conform to Japanese standards stipulated in the Electric Appliance Regulatory Act. (If using a sheathed wire, the grounding shown in the figure on the left is unnecessary.)

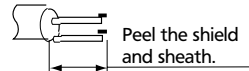

4. Reattach the upper part of remote controller.

Be careful not to pinch the wiring when attaching.

NOTE

1. The switch box and wiring for connection are not included.
2. Do not directly touch the PC board with your hand.

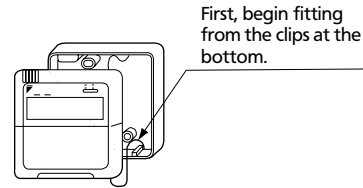

When controlling one HRV unit with two remote controllers

Change the MAIN/SUB changeover switch setting as described below.

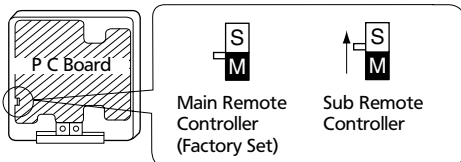

Set one remote controller to "main," and the other to "sub."

NOTE

- If controlling with one remote controller, be sure to set it to "main."
- Set the remote controller before turning power supply on.

"88" is displayed for about one minute when the power supply is turned on, and the remote controller cannot be operated in some cases.

Operation with the remote control exclusively for Air conditioning operation HRV units. (BRC301B61)

For non-independent systems, starting / stopping operation and timer operation may not be possible. Use the air conditioner remote control or the Centralized control in such cases.

- ① Operation lamp
This pilot lamp (red) light up while the unit is in Operation.
- ② Operation / Stop button
When pushed once, the unit starts operating.
When pushed twice, the unit stops.

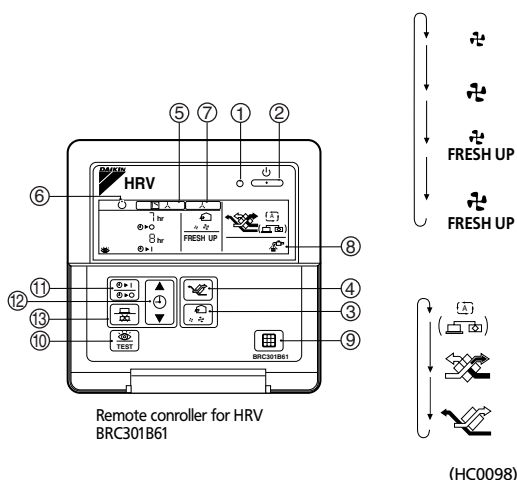

- ③ Air flow rate changeover button
Air flow rate can be changed over to "↻"
[Low] mode or "↻" [High] mode,
"↻ FRESH UP" [Low FRESH UP] mode,
"↻ FRESH UP" [High FRESH UP] mode.
For "FRESH UP" operation
When this indication does not show: The volume of outdoor air supplied into the room and that of the room air exhausted outdoors is equivalent.
For "FRESH UP" operation,
 - If it is set to "Fresh up air supply": The volume of outdoor air supplied into the room is larger than that of room air exhausted outdoors. (This operation prevents the odor and moisture from kitchens and toilets from flowing into the rooms.)
 - If it is set to "Fresh up air exhaust": The volume of room air exhausted outdoors is larger than that of outdoor air supplied into the room. (This operation prevents the hospital odor and floating bacteria from flowing out to the corridors.)
- ④ Ventilation mode changeover button
"⏸" (Automatic) mode The temperature sensor of the unit automatically changes the ventilation of the unit in [Bypass] mode and [Heat Exchange] mode.
"↻" (Heat Exchange) mode..... In this mode, the air passes through the heat exchange element to effect [Total Heat Exchanging] ventilation.
"⏸" (Bypass) mode..... In this mode, the air does not pass through the heat exchange element but passes it to effect [Bypass] ventilation.

- ⑤ Indication of operation control method:

When the operation of HRVs are interlocked with the air conditioners, this indication may be shown. While the indication is shown, the ON / OFF of HRVs cannot be operated by the HRV remote control.
- ⑥ Indication of operation standby:

It indicates the precooling / preheating operation. This unit is at stop and will start operation after the precooling / preheating operation is over. Precooling / preheating operation means the operation of HRVs is delayed during the startup operation of interlocked air conditioners such a before the office hours. During this period the cooling or heating load is reduced to bring the room temperature to the set temperature in a short time.
- ⑦ Indication of centralized control:

When a remote control for air conditioners or devices for centralized control are connected to the HRVs, this indication may show. During this indication appears on the display, the ON / OFF and timer operation may not be possible with the HRV remote controls.
- ⑧ Indication of air filter cleaning
When the indication "⏸" appears on the display, clean the filter.
- ⑨ Filter signal reset button
- ⑩ Inspection button
This button is to be used only for service. It is not to be used normally.

How To Operate With Timer

- ⑪ Push the button "". and select either one of "⌚" or "⌚".
Each time the button is pushed, the indication changes as shown below.

"No indication"
- ⑫ Push the button "". and set the time.
Each time when "▲" is pushed, the time advances one hour.
Each time when "▼" is pushed, the time goes back one hour.
- ⑬ Push the button "".
Then, the reservation is finished.
Either "⌚" or "⌚" changes from flashing to lighting. After the reservation is finished, the remaining time is indicated in the display.
For cancelling the timer operation, push the button "". once again.
The indication disappears.

BRC3A61 - Remote control (hotel use)



Features

Simplified remote control for hotel applications - BRC3A61

- compact, user friendly unit
- ideal for use in hotel bedrooms

Operation buttons:

- ON / OFF
- Fan speed control
- Temperature setting

Display

- Heat Recovery Ventilation (HRV) in operation
- Set temperature
- Operating mode
- Centralised control indication
- Fan speed
- Defrost / hot start
- Malfunction

(Unit: mm)

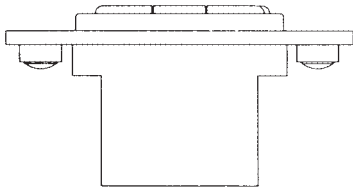
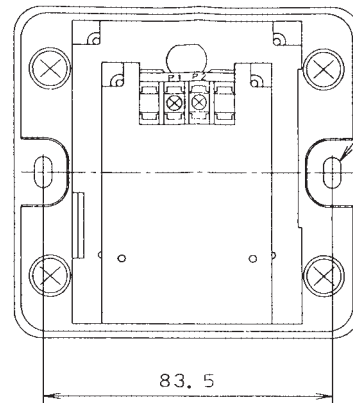
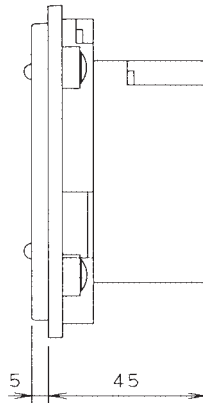
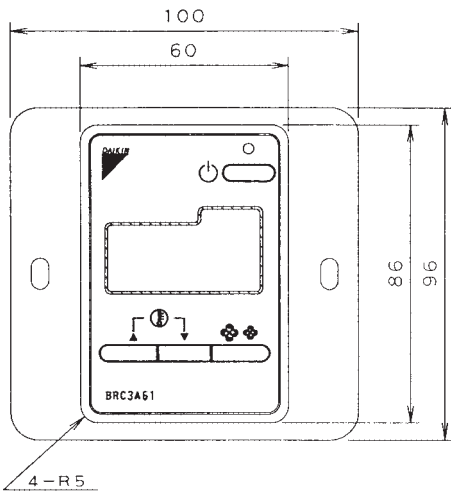

BRC3A61	FXSQ
	FXMQ
	FXDQ
	RXYQ/REYQ

BRC4C* / BRC7C* - Infrared remote control



Features

Infrared remote control - BRC4C* / BRC7C*

Operation buttons:

- ON / OFF
- Timer mode start / stop
- Timer mode on / off
- Programmed time
- Temperature setting
- Air flow direction (FXHQ, FXFQ, FXCQ and FXAQ models only)
- Operating mode
- Fan speed control
- Filter sign reset
- Inspection test / operation

Display

- Operating mode
- Battery change
- Set temperature
- Air flow direction (FXHQ, FXFQ, FXCQ and FXAQ models only)
- Programmed time
- Inspection test / operation
- Fan speed

(Unit: mm)

Remote control dimensions

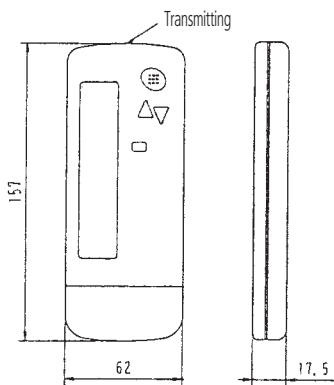

Remote control holder installation procedure (installation to wall surface)

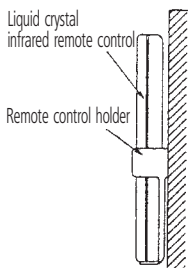

Service space for ceiling installation

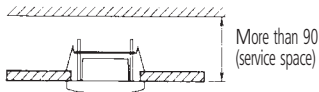

Receiver

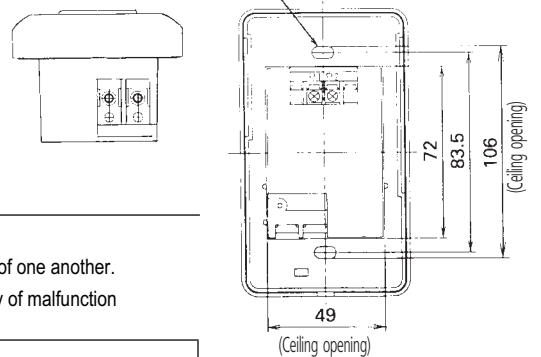
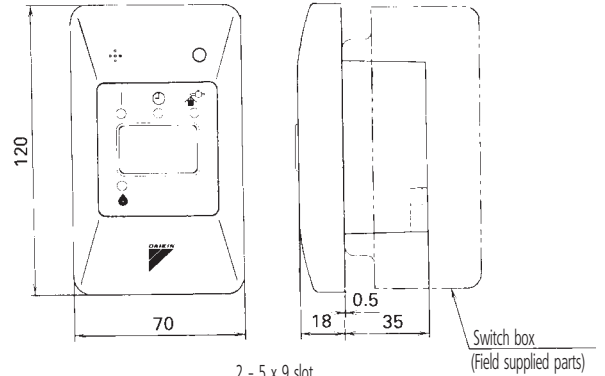

NOTES

- 1 Do not install more than 3 receivers in the vicinity of one another.
- 2 With 4 or more units, there is always the possibility of malfunction

BRC4C62	Heat pump	FXSQ, FXDQ, FXMQ, FXLQ, FXNQ
BRC4C64	Cooling only	
BRC4C61	Heat pump	FXKQ
BRC4C63	Cooling only	

BRC7C510,511 - Infrared remote control

- Receiver installation procedure

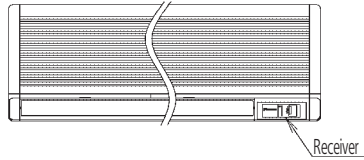

- Remote control dimensions

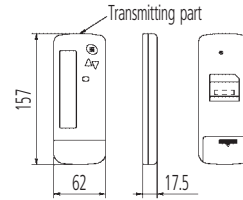

- Receiver detail

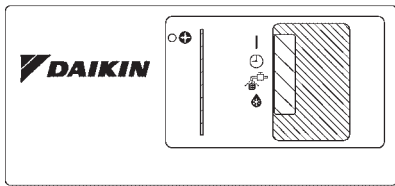

- Remote control holder installation procedure
<Installation to wall surface>

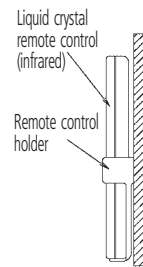

BRC7C512,513 - Infrared remote control

(Unit: mm)

- Remote control dimensions

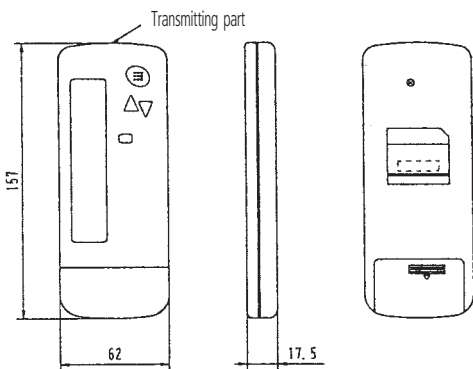

- Receiver installation procedure

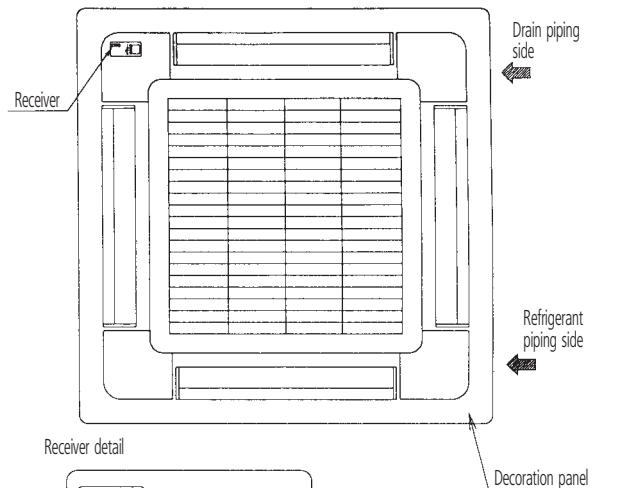

- Remote control holder installation procedure
(installation to wall surface)

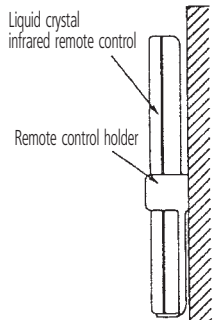

- Receiver detail

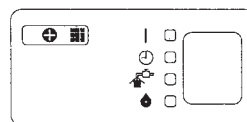

BRC7C512	Heat pump	FXFQ
BRC7C513	Cooling only	

BRC7C528,529 - Infrared remote control

- Remote control dimensions

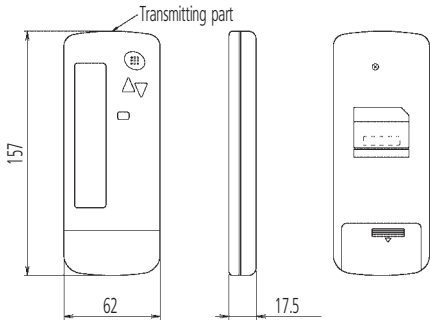

- Remote control holder installation procedure

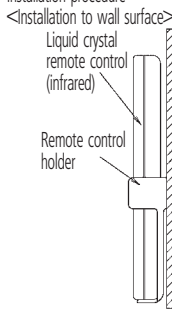

- Receiver installation procedure

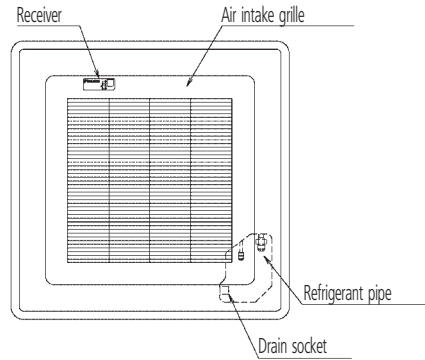

- Receiver detail



- Infrared remote control kit for each decoration panel

BRC7C62,67 - Infrared remote control

(Unit: mm)

- Remote control dimensions

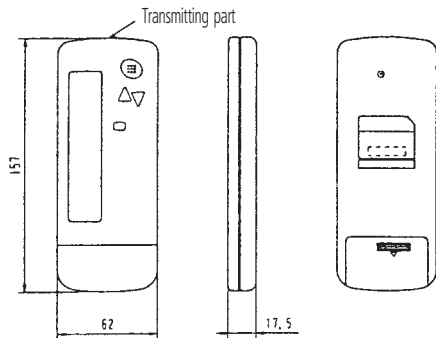

- Remote control holder installation procedure (installation to wall surface)

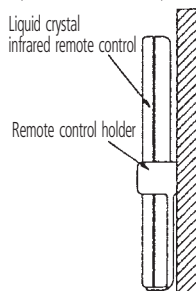

- Receiver installation procedure

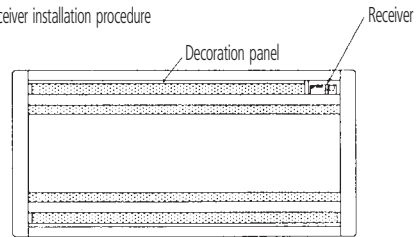

- Receiver detail

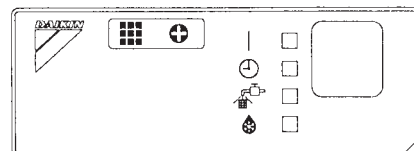

BRC7C62	Heat pump	FXCQ
BRC7C67	Cooling only	

BRC7E51 - Infrared remote control

- Remote control dimensions

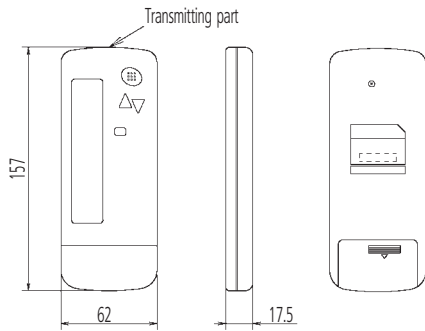

- Remote control holder installation procedure
<Installation to wall surface>

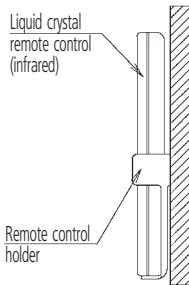

- Receiver installation procedure

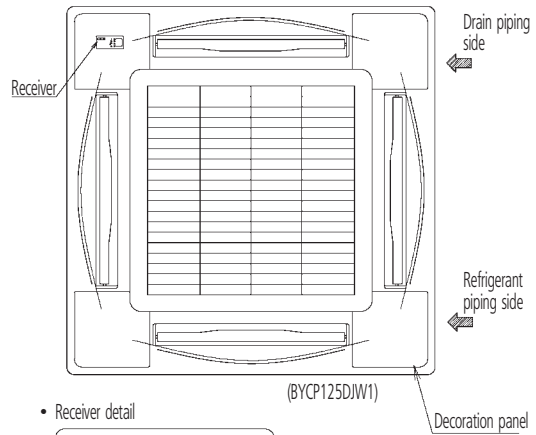

- Receiver detail

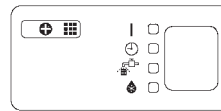

- Infrared remote control kit for each decoration panel

Infrared remote control kit	Decoration panel
BRC7E51	BYCP125DJW1

BRC7E530,531 - Infrared remote control

(Unit: mm)

- Remote control dimensions

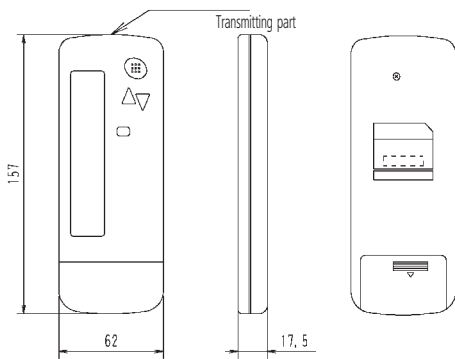

- Remote control holder installation procedure
(Installation to wall surface)

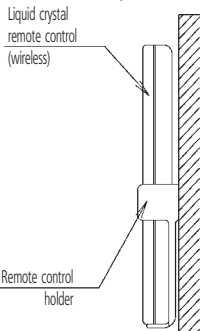

- Receiver installation procedure

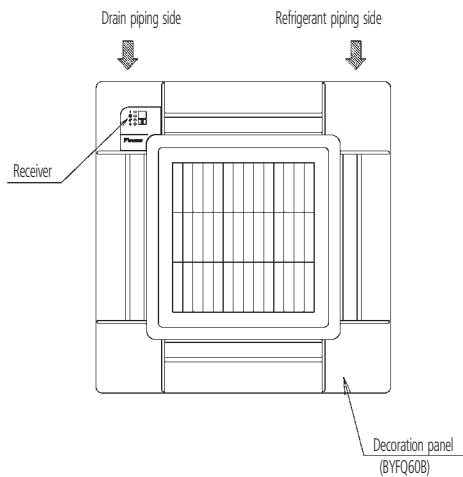

- Receiver detail

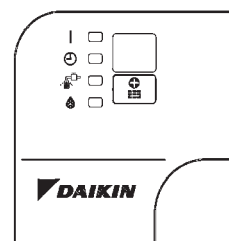

BRC7E530	Heat pump	FFQ
BRC7E531	Cooling only	

BRC7E618,619 - Infrared remote control

(Unit: mm)

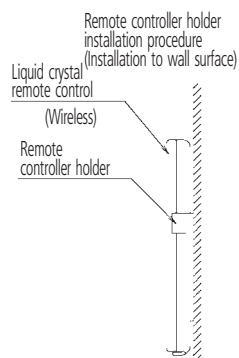
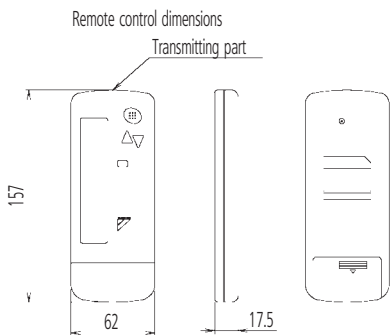

Receiver installation procedure

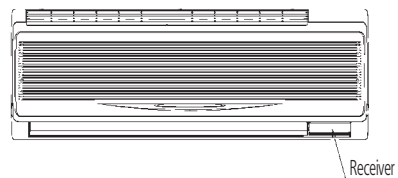

Receiver detail



BRC7E618	Heat pump	FXAQ
BRC7E619	Cooling only	

BRC7E63,66 - Infrared remote control

(Unit: mm)

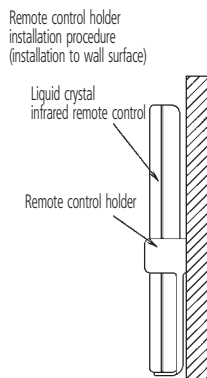
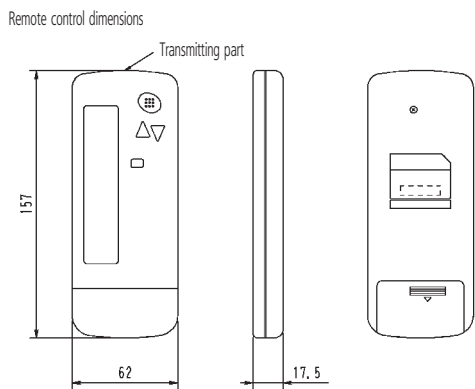

Receiver installation procedure

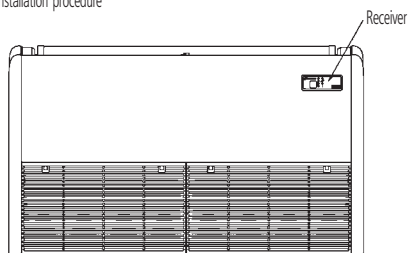

Receiver detail

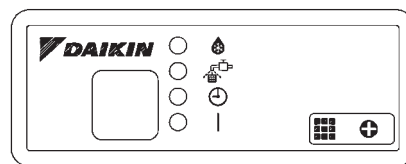

BRC7E63	Heat pump	FXHQ
BRC7E66	Cooling only	

BRP4A50 - Adapter for heater control kit

Heater control kit

Operation range of the HRV is “ -10 C to 50 CDB 80% RH or below.”

When operating the HRV units at or below -10 C of the outdoor air temperature, use preheater (field supplied) to preheat outdoor air.

This kit is required to have ON / OFF delay control when preheater is used. (Initial setting is required.)

Cautions

- For electric heater, safety devices and installation location, follow the standards or regulations of each country.
- Use nonflammable duct for the electric heater. Be sure to keep 2 m or more between the heater and HRV unit for safety.
- For the HRV units, use a different power supply from that of the electric heater and install a circuit breaker for each.

Electric heater capacity formula

$$\text{Heat capacity P (kW)} = 0.29 \times \text{Air flow rate} \times \text{Temp.} / 860$$

For VAM500FJVE when Air flow rate = 500m³ / h (Ultra-high) and preheater so that the outdoor temp. rise from -20 C to -10 C (Temp. = 10 deg)

$$P = (0.29 \times 500 \times 10) / 860 = 1.68 \text{ (kW)}$$

Check the temperature rise at low notch.

For 2kW heater, when 300m³ / h

$$T = (860 \times P) / (0.29 \times \text{Air flow rate})$$

$$= (860 \times 2) / (0.29 \times 300) = 19.7 \text{ deg}$$

Therefore - 20 + 19.7 = -0.3 C

Cautions at initial setting

- Make sure to set infrared control of HRV at initial setting as follows:
(for ON / OFF delay)

	Setting mode	Setting switch no.	Setting position
Heat setting	19	8	03 or 04

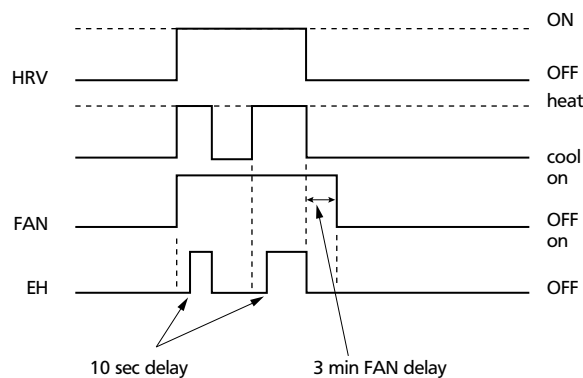

- Heater operating condition
Heater starts operation when it is judged as Heating operation.
(Judged from VRV signal of heating operation or HRV signal of thermostat.)
- ON / OFF delay
Heater starts 10 seconds after HRV starts operation.
Fan stops 3 minutes later after HRV stops operation.

BRP4A50 - Adapter for heater control kit
Installation example

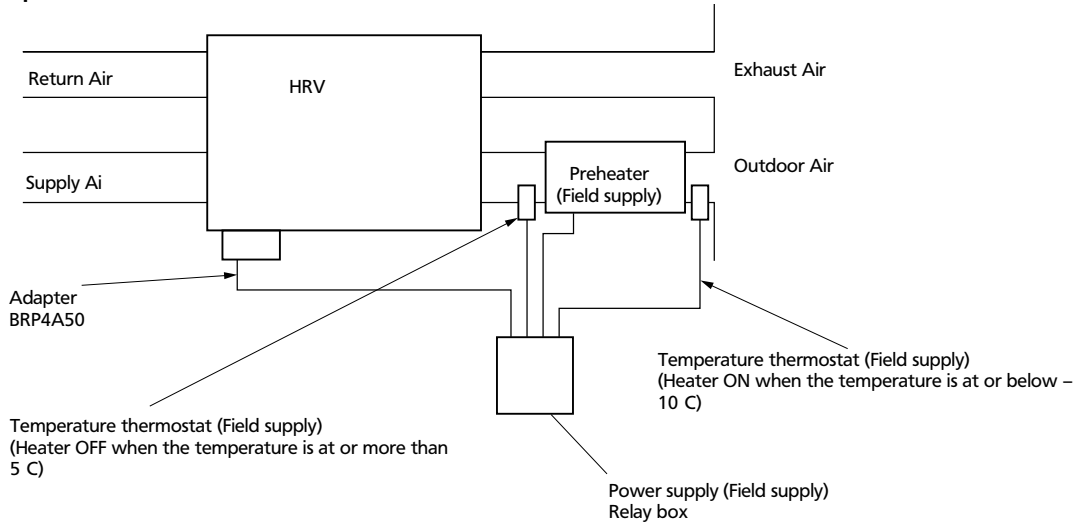

Wiring

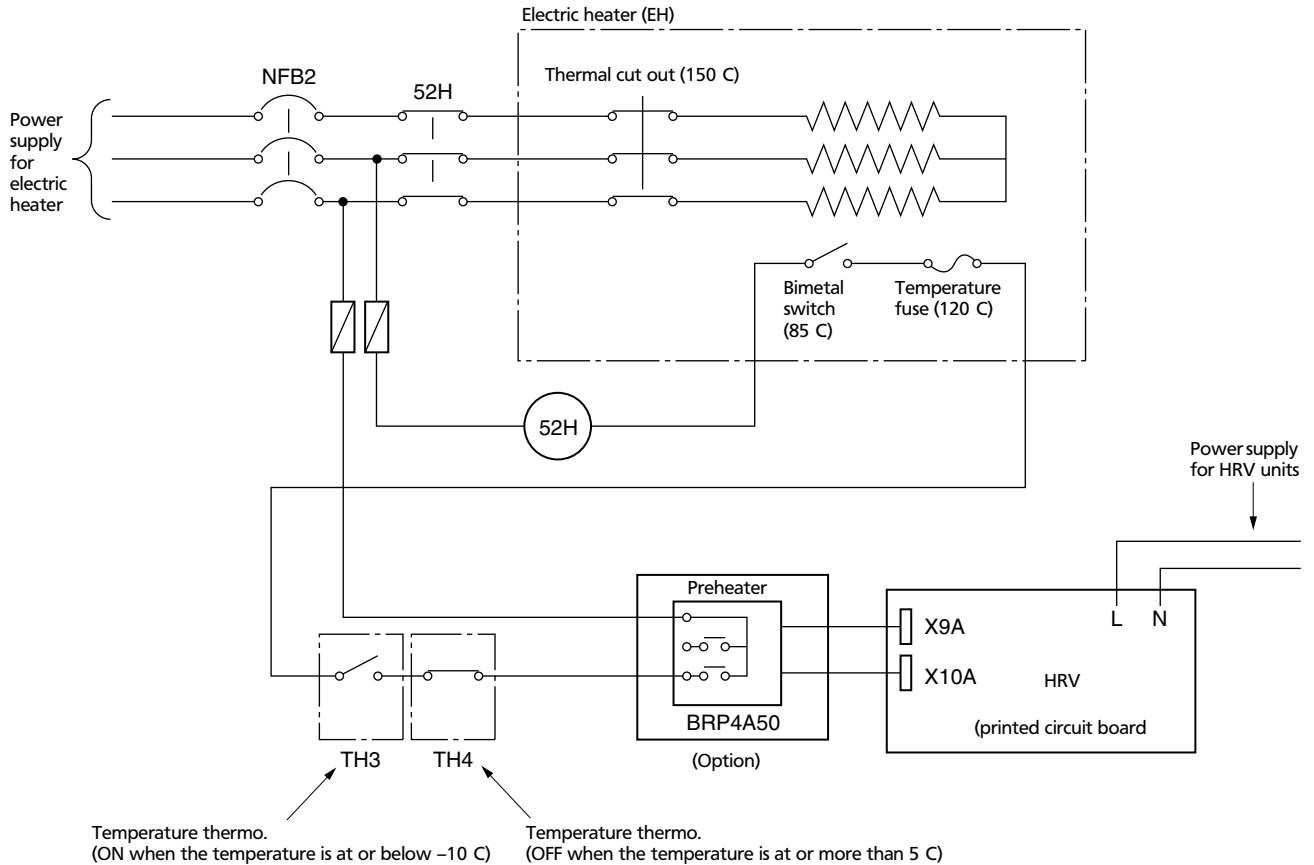

Symbol	Part	Installation Place	Field supply
52H	Relay	Install a relay box at site	Field supply
EH	Electric heater (Bimetal switch, Temperature fuse, Thermal cut out etc. (built in))	Duct	Field supply
TH3	Temperature thermostat (ON when the temperature is at or below -10 C)	Duct (Front of EH)	Field supply
TH4	Temperature thermostat (OFF when the temperature is at or more than 5 C)	Duct (behind of EH)	Field supply

Note:

Make sure to install TH3 and TH4 for safety.

Test run

After completing the installation of the system, check again to make sure that no error was made in wiring or switch setting on the printed circuit boards of the HRV units.
 Then, turn on the power of the HRV units. Refer to the manual of the infrared control of each unit (infrared control for air conditioner, central control unit, etc.) for conducting a trial operation.

BRP4A50 - Adapter for heater control kit

Heater control kit

Accessories

See the right for componens.

Fixing Screw	2 pcs.
Clamp	2 pcs.

Installation

Install the Heater control kit to the outside of switch box for HRV unit as shown below.

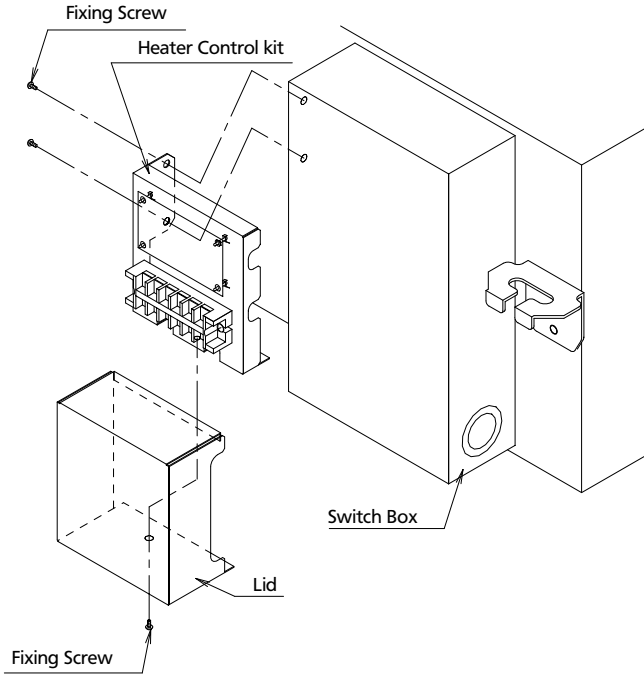

<< Cautions >>

< Switch setting of the HRV unit >

The initial setting is required by infrared control for indoor unit or HRV unit.

See the INSTALLATION MANUAL of HRV (Local setting) Electric heater setting ON, OFF delay [19 (29 • 8 • 03]

* The initial setting is necessary for safety.

Switch box

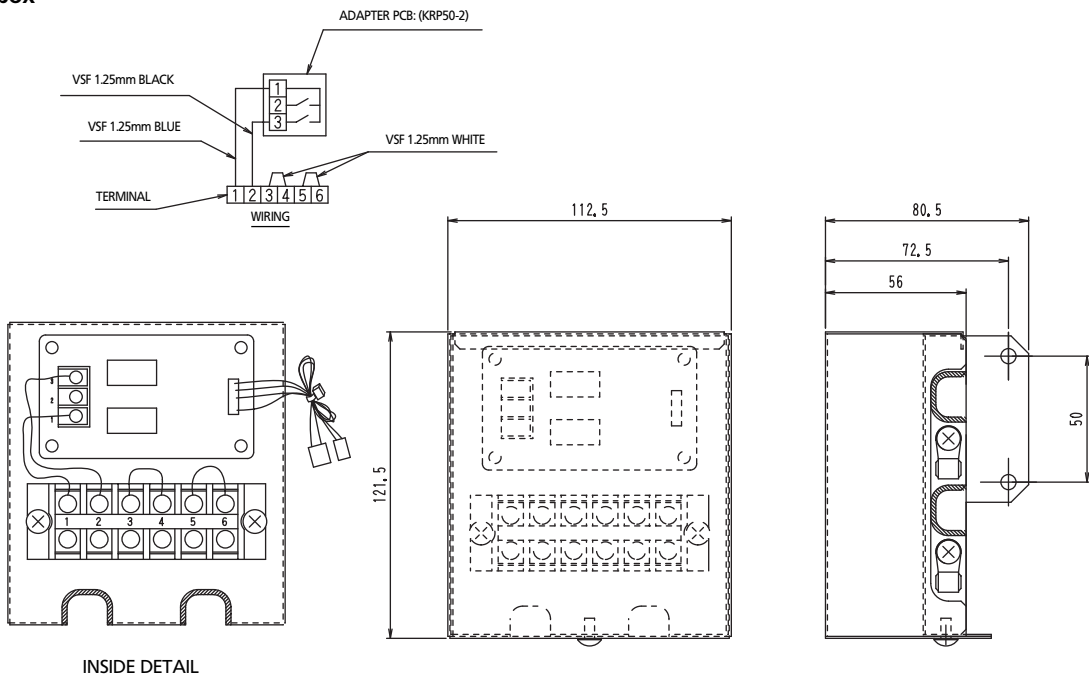

BSVQ-M - BS Box

Specifications

Technical specifications

BSVQ-M			100	160	250	
TOTAL CAPACITY INDEX OF CONNECTABLE INDOOR UNIT			≤100	100 < X ≤160	160 < X ≤250	
MAXIMUM NUMBER OF CONNECTABLE INDOOR UNITS			5	8	5	
NOMINAL INPUT	Cooling	W	21	21	21	
	Heating	W	21	21	21	
DIMENSIONS		mm	185x310x280			
WEIGHT		kg	9	9	10	
CASING			galvanised steel plate			
PIPING CONNECTIONS	Indoor unit	Liquid	mm	9.5 (flare) *1	9.5 (flare)	9.5 (flare)
		Gas	mm	15.9 (flare) *1	15.9 (flare)	22.2 (flange) *2
	Outdoor unit	Liquid	mm	9.5 (flare) *1	9.5 (flare)	9.5 (flare)
		Suction gas	mm	15.9 (flare) *1	15.9 (flare)	22.2 (flange) *2
		Discharge gas	mm	12.7 (flare) *1	12.7 (flare)	19.1 (brazing) *3
SOUND ABSORBING THERMAL INSULATION MATERIAL			flame and heat resistant foamed polyethylene			

NOTES

- If the total capacity of all indoor units connected to the system is less than 7,1kW, connect the attached pipe to the field pipe. (Braze the connection between the attached pipe and the field pipe)
- Use the field flanged pipe. Also with a 200 class indoor unit, connect the attached reducer to the field pipe. (Braze the connection between the attached pipe and field pipe)
- Use the attached pipe
- Information was not available at the time of publication
- Please note that connectable indoor unit for BSVQ250M is from size 50 onwards. This means that indoor size 20 to 40 should NOT be connected to BSVQ250M. The explanation of possible trouble is that there is mainly a problem with the refrigerant side: if only this BSVQ is in heating, and all the other BSVQ are in cooling, there is a high risk of liquid back to the suction side (by insufficient evaporation of liquid used for extra sub-cool). If such operation of BSVQ250M runs for a while with an indoor thermostat-on of index 40 or less, it can result in compressor failure. The communication itself will work as the BSVQ does not know its size, so it can not check if indoor index is correct or not.
- BS boxes cannot be installed upside down
- In case of sound sensitive application, please contact your local daikin representative for more details and recommendations

Electrical specifications

BSVQ-M			100	160	250
CURRENT	Minimum circuit amps (MCA)	A	0.2		
	Maximum fuse amps (MFA)	A	15		
POWER SUPPLY		V1	1~, 50Hz, 220-240V		
VOLTAGE RANGE		Min ~ Max	198 ~ 264		

NOTES

- Voltage range: units are suitable for use on electrical systems where voltage supplied to units terminals is not below or above listed range limits.
- Maximum allowable voltage unbalance between phases is 2 %
- MCA / MFA:
MCA = 1.25 x FLA
MFA ≤4 x FLA
(Next lower standard fuse rating. Min. 15A)
- Select wire size based on the MCA
- Instead of fuse, use circuit breaker
- For more details concerning conditional connections, see <http://www.daikineurope.com/extranet>, select "Daikin Documentation" and select "conditional connection", "the requested product type" and "English" from the drop down lists, click the search button. Finally, click on the document title of your choice.

Safety device settings

BSVQ-M	100	160	250
PC BOARD FUSE		250V, 5A	

Accessories

BSVQ-M	100	160	250
COOL/HEAT SELECTOR		KRC19-26	
FIXING BOX		KJB111A	

BSVQ-M - BS Box

BSVQ100,160M

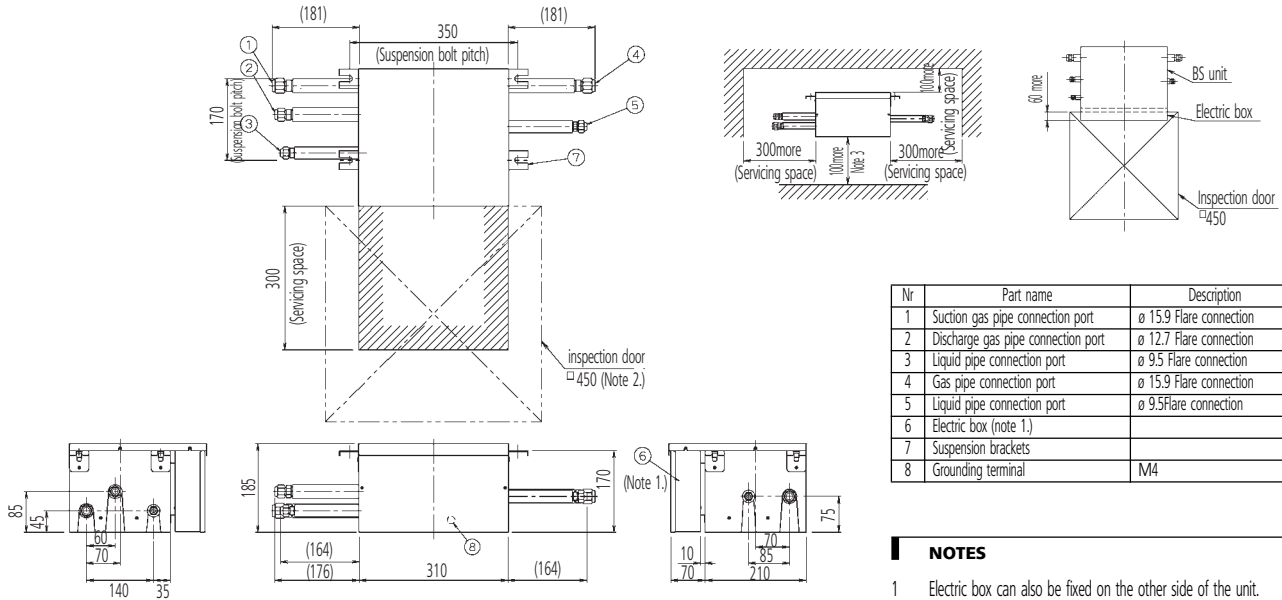

Nr	Part name	Description
1	Suction gas pipe connection port	ø 15.9 Flare connection
2	Discharge gas pipe connection port	ø 12.7 Flare connection
3	Liquid pipe connection port	ø 9.5 Flare connection
4	Gas pipe connection port	ø 15.9 Flare connection
5	Liquid pipe connection port	ø 9.5 Flare connection
6	Electric box (note 1.)	ø 9.5 Flare connection
7	Suspension brackets	
8	Grounding terminal	M4

NOTES

- 1 Electric box can also be fixed on the other side of the unit.
- 2 Be sure to install an inspection door at electric box side.
- 3 Install a servicing space in the bottom of electric box 100mm or more. When a service space cannot be installed, install a inspection door in the position of the following figure.

BSVQ250M

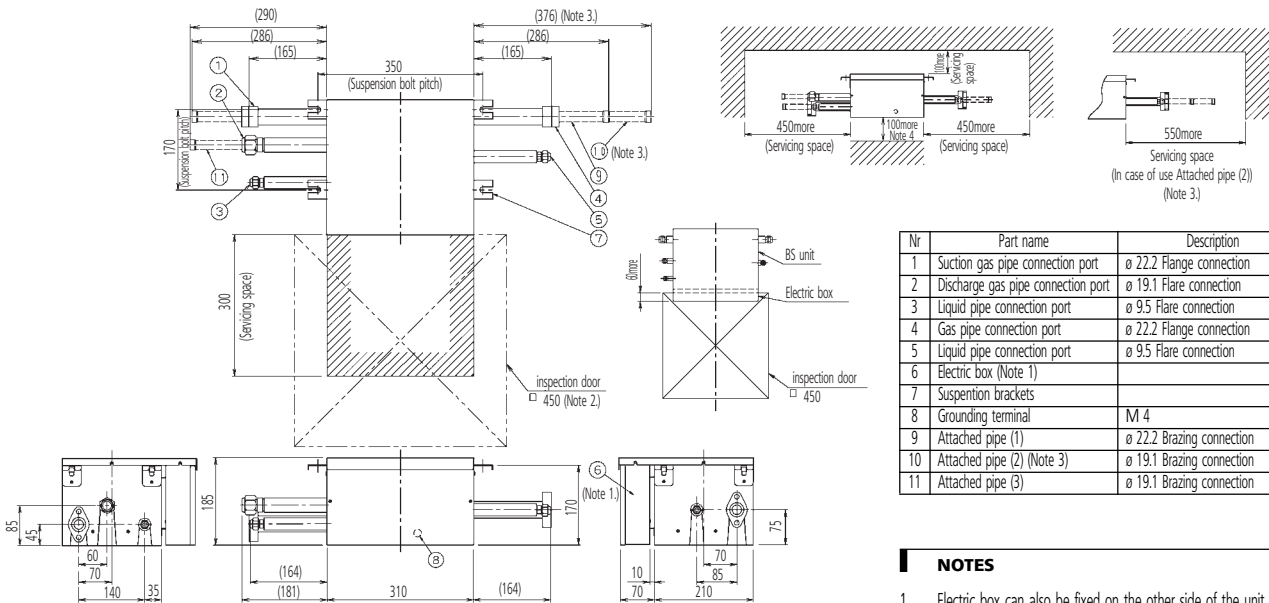

Nr	Part name	Description
1	Suction gas pipe connection port	ø 22.2 Flange connection
2	Discharge gas pipe connection port	ø 19.1 Flare connection
3	Liquid pipe connection port	ø 9.5 Flare connection
4	Gas pipe connection port	ø 22.2 Flange connection
5	Liquid pipe connection port	ø 9.5 Flare connection
6	Electric box (Note 1.)	
7	Suspension brackets	
8	Grounding terminal	M 4
9	Attached pipe (1)	ø 22.2 Brazing connection
10	Attached pipe (2) (Note 3)	ø 19.1 Brazing connection
11	Attached pipe (3)	ø 19.1 Brazing connection

NOTES

- 1 Electric box can also be fixed on the other side of the unit.
- 2 Be sure to install an inspection door at electric box side.
- 3 Attached pipe (2) is only used in case of connecting with indoor unit 200 type.
- 4 Install a servicing space in the bottom of electric box 100mm or more. When a service space cannot be installed, install a inspection door in the position of the following figure.

DAM411B51 DIII board - Extension of 3x DIII lines (3 x 64) indoor units

Option DIII board (DAM411B51) outside drawing
 This kit is for adding 3 ports to the DIII-NET communication port by installing it on the BACnet Gateway DMS502A51. The kit can not be solely used.

Outside dimension of PCB

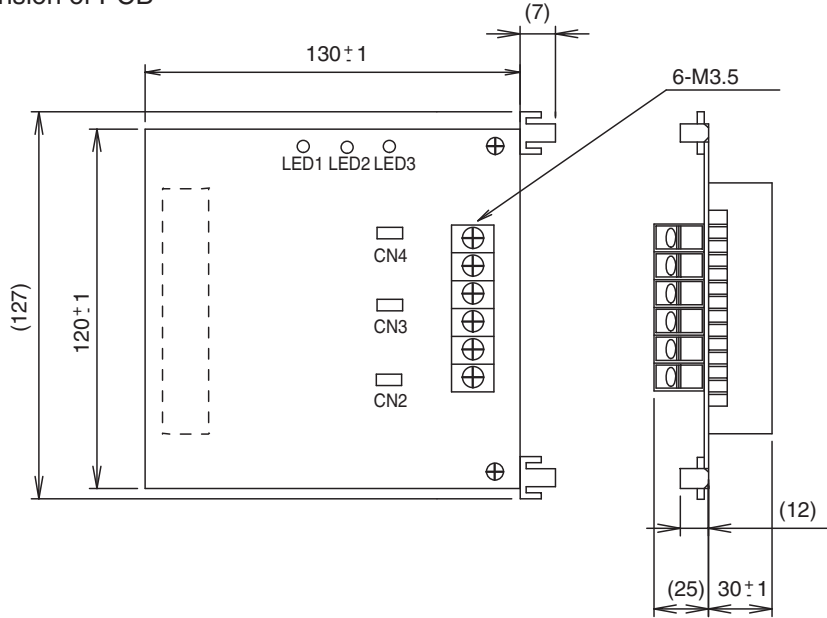

Panel for DIII

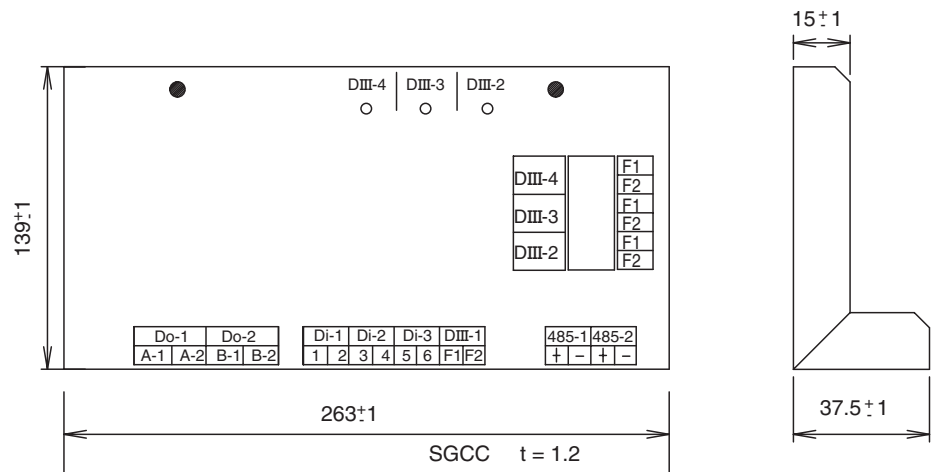

Panel for DIII and Di
 (This is to be used when both DAM411B51 and DAM412B51 are installed)

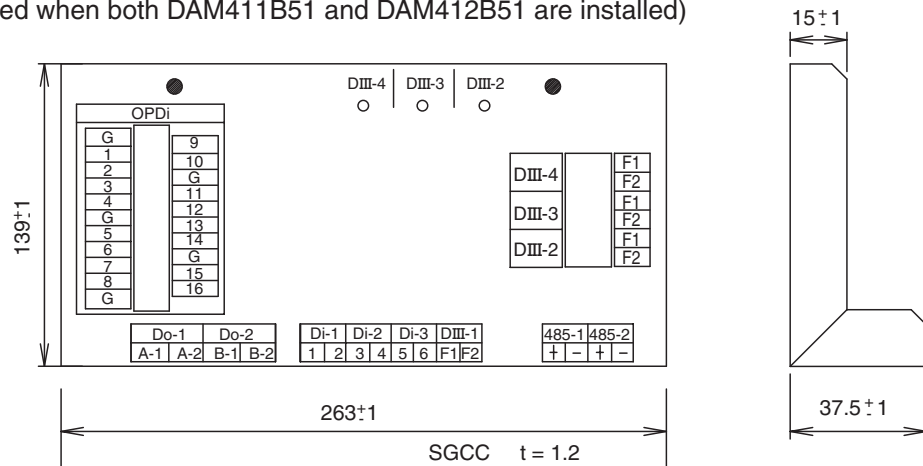

DAM412B51 Digital input/output (for forced shutdown)

Option Di board (DAM412B51) outside drawing
Expansion kit, installed on the BACnet Gateway (DMS502A51), to provide Max 4 digital inputs
such as forced stop. Not usable independently

Outside dimension
of PCB

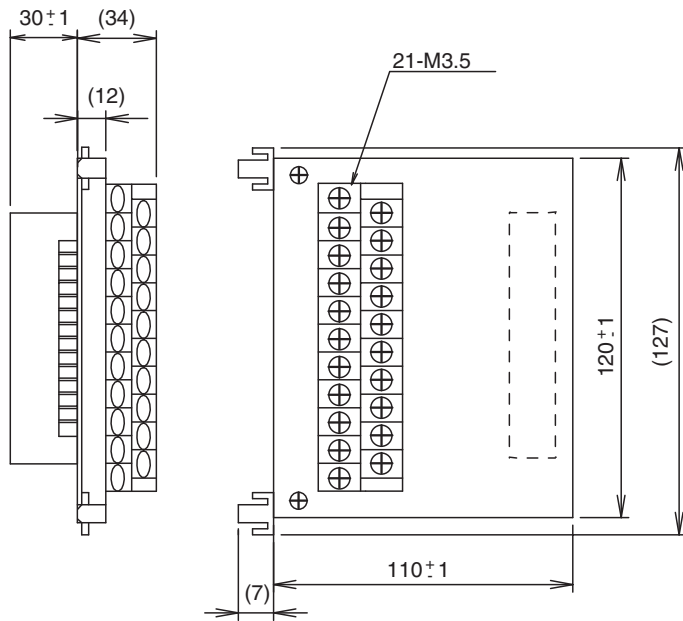

2

Panel for Di

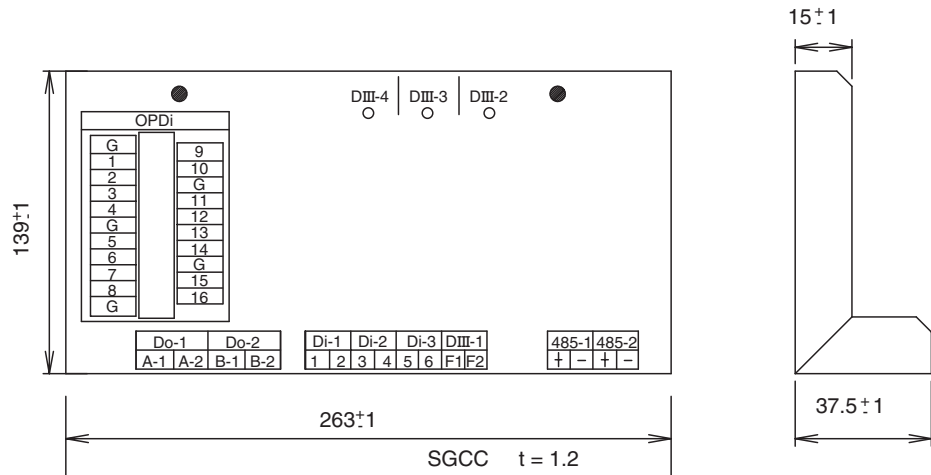

Panel for DIII and Di
(This is to be used when both DAM411B51 and DAM412B51 are installed)

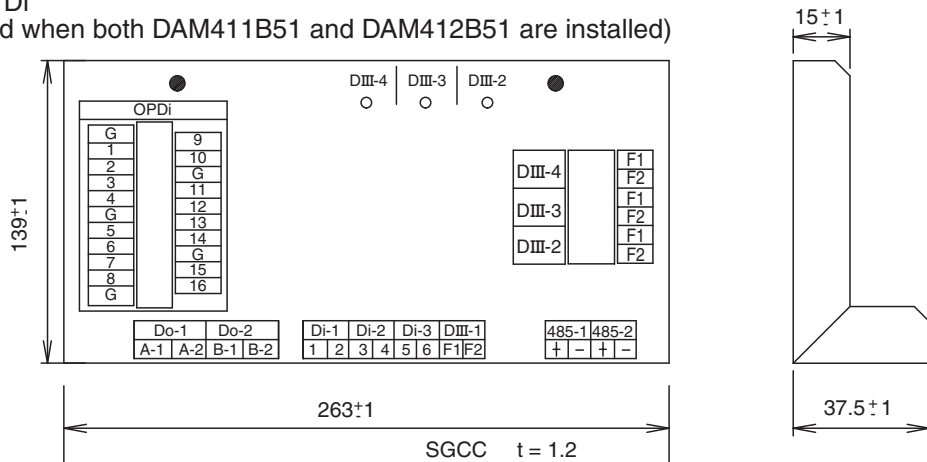

DAM602B51 / DAM602B52

Model Series (Factory in Charge)

iPU Model Name	Number of units to be connected	Number of DIII-NET port	Number of Digital input
DAM602B51	256 units	4	20
DAM602B52	128 units	2	

Optional	Model name
DAM002A51	Power Proportional Distribution software
DAM003A51	ECO software
DAM004A51	Web software

* MADE IN JAPAN



Concept and Main Specifications

<Product concept>

- **A/C monitoring panel targeting the simplified BMS market.**
The needs of the current i-Manager A/C monitoring panel will be covered continuously, and we make inroads into the BMS market by expansion of functions.
- **Expansion of function to be realized by optional software.**
Customers can select required functions.
Price can be set up in accordance with required functions.

<Major Specification>

Major modified functions		I-Manager II	I-Manager III
Constitution of iPU (Number of III ports)		2,3,4 port version	2,4 port version
Power proportional distribution		○	DAM002A51 (option)
ECO (Energy saving/Power limit control)		○	DAM003A51 (option)
Web function	Individual control	—	DAM004A51 (option)
	Monitoring of abnormality *1		
	Control setting *2		
	Power proportional distribution data *3		
Analog interlock function		—	○
Corresponding with air cooled chillers and CHESBAC (Monitoring of AIRNET data)		—	○
Number of control points of control group		Max. 128 points	Max. 1024 points
Optimum starting control (from Jan/2007)		—	○
Indication of history of operation source (from Jan/2007)		—	○
Monitoring of continuous operation time		○	
Calendar		Rotation	1-year use disposable
Use of built-in optional modem for AIRNET		—	○

*1: E-mail communication function is included when the equipment is abnormal.
 *2: Schedule control setting, Set temperature control setting
 *3: PPD software(DAM002A51) is required for the PPD data available on web.

DCS002C51 Power Proportional Distribution (PPD) software

Function and Outline

Power Proportional Distribution Card, in combination with an existing intelligent Touch Controller, enables to proportionally calculate and display electricity amount used by air conditioner per indoor unit.

Main Functions

- 13 months data storage possible
- Data available per hour per indoor unit
- Power proportional distribution may be calculated for 2 x 64 indoor units at maximum.
- Power proportion distribution results data may be saved into a PCMCIA card.
Data is saved CSV format generally applied to personal computers, so bills may be issued by use of a general purpose table calculation software package in easy manners.
(A personal computer and a general purpose table calculation software package may be available separately.)

Precautions

This system calculates electricity consumptions by size of indoor units, run time, expansion vales open gap, suction rate and the number of pulses from the power meters installed at the Outdoor Units.
This method is not calculated by direct measurement alone.

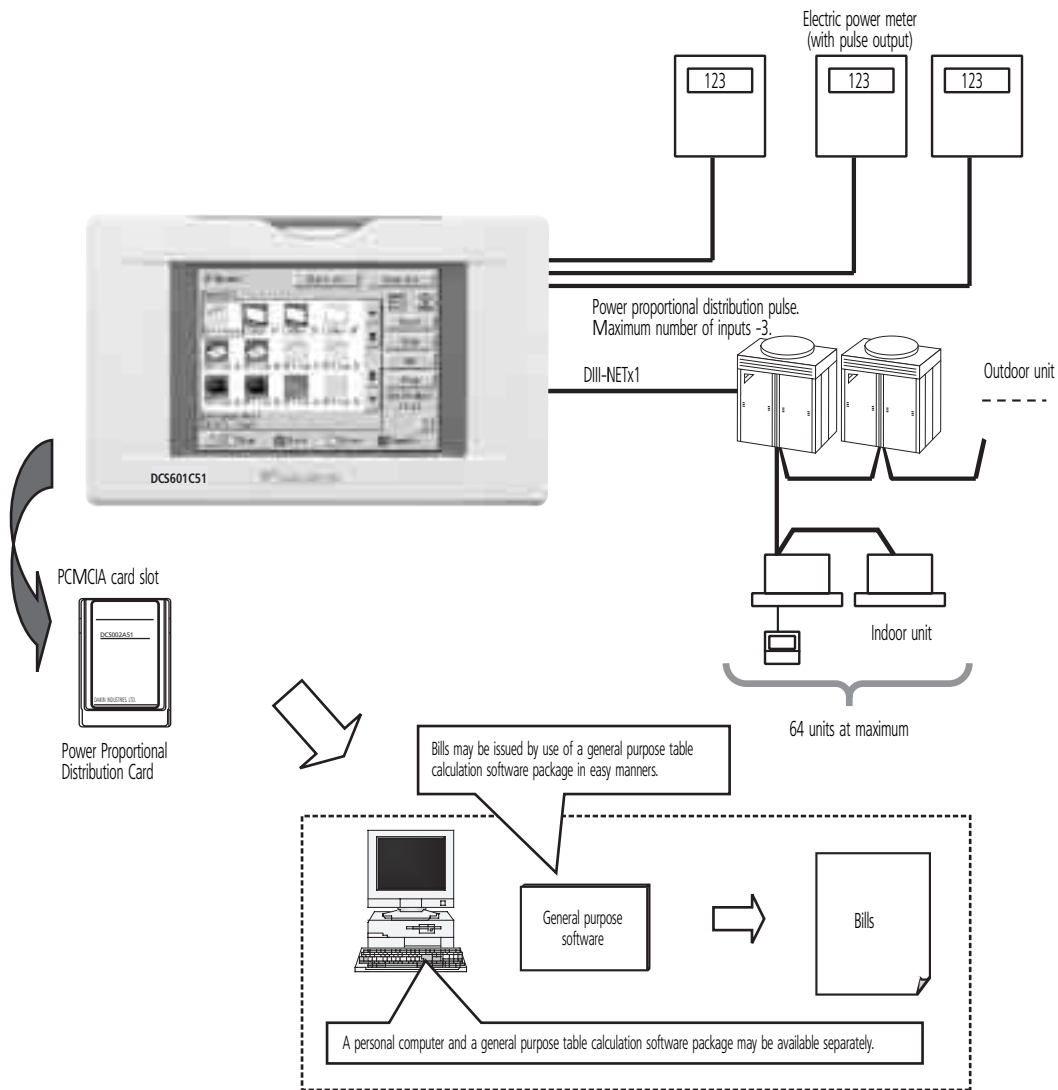

DCS004A51 Email/Web software

Web System of the intelligent Touch Controller

The Administrator can assign (restrict) one or more air conditioners to each General User. In the following Figure 1, User 01, User 02, and User 03 can operate and monitor only their local air conditioners. However User 64 can operate/monitor air conditioners that other General Users can also operate/monitor.

Figure 1: Example of user setting

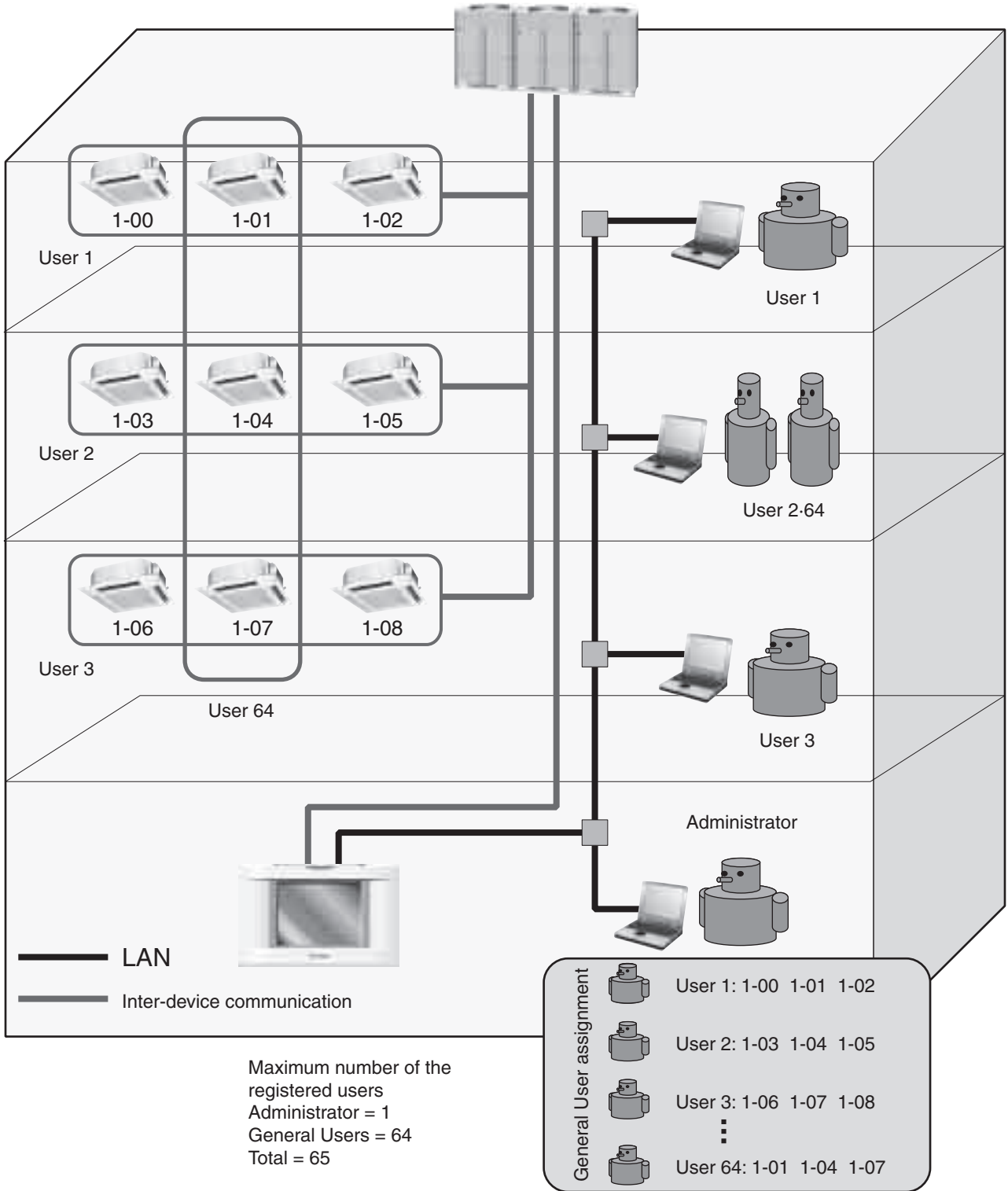

DCS301B51 - Unified ON/OFF control



Providing simultaneous and individual control of 16 groups of indoor units.

- A maximum of 16 groups (128 indoor units) can be controlled
- 2 remote controls in separate locations can be used
- Operating status indication (normal operation, alarm)
- Centralised control indication
- Maximum wiring length of 1,000m (total:2,000m)

(Unit: mm)

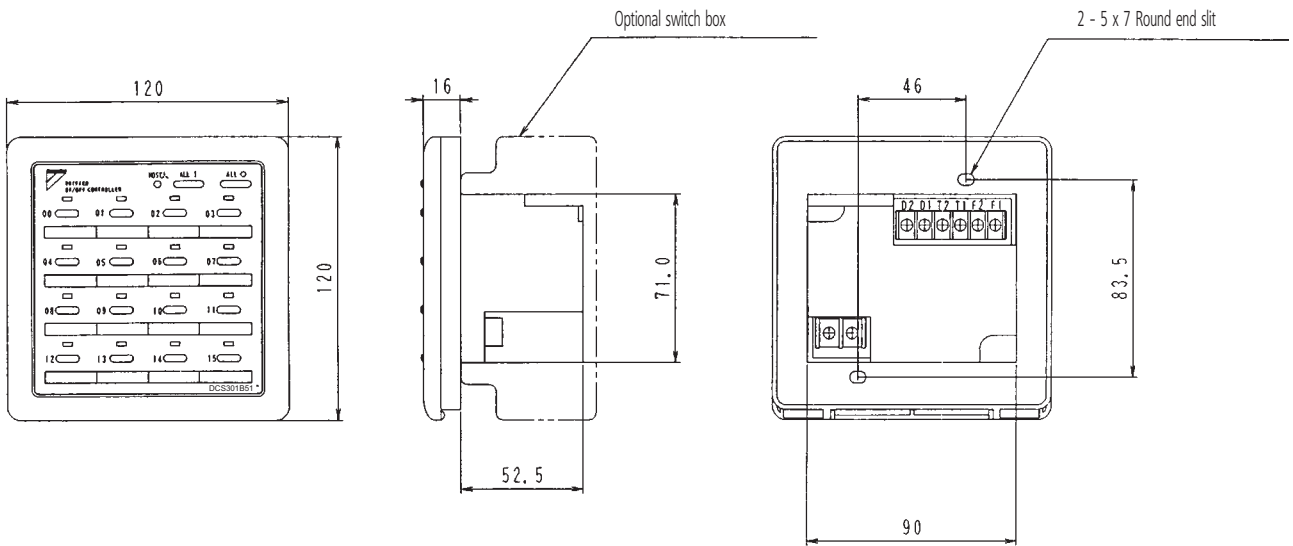

NAMES AND FUNCTIONS

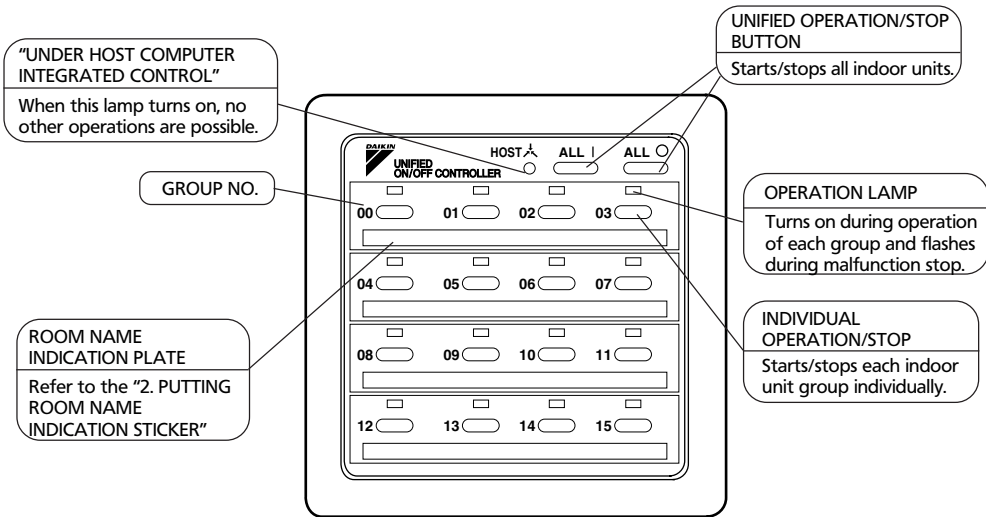

DCS301B61

Turns up to 16 groups of indoor units (max. 128 units) on/off (operation/stop) by individual group or all at once, and lets you check display of operation/malfunction at the same time.



- For a maximum of 16 groups of indoor units (max. 128 units), unified operation/stop or individual operation/stop can be performed with this optional accessory. Also allows you check operation/error display at a glance.
- By combining with a central remote controller and schedule timer, you can construct a system that matches the size and use of the building.
- Up to 8 units connectable within 1 system.
Up to 16 units in the double central control mode.
- Features thin design of a mere 16mm in thickness. (Uses JIS recessed box for 2.)
- Wiring can be up to 1km in length. Applicable wiring methods include bus and star in addition to crossover type.
- Can be used in combination with other D-BACS equipment.

Dimensions

Unit (mm)

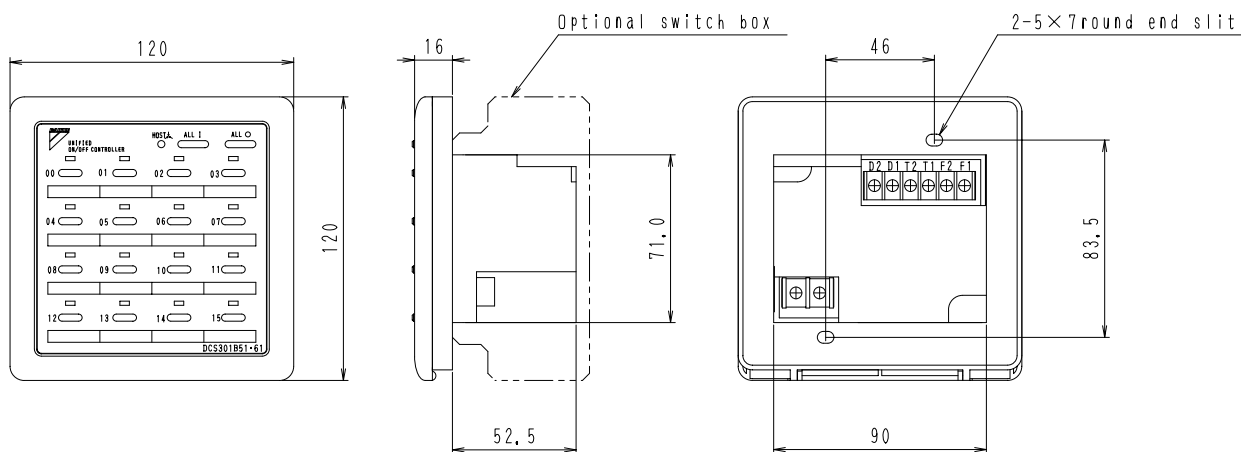

3D050339

DCS302C51 - Centralised remote control for 64 groups



- Providing individual control of 64 groups (zones) of indoor units.
- A maximum of 64 groups (128 indoor units, max. 10 outdoor units) can be controlled.
 - A maximum of 128 groups (128 indoor units, max. 10 outdoor units) can be controlled via 2 central remote controls in separate locations.
 - Zone control
 - Group control
 - Malfunction code display
 - Maximum wiring length of 1,000m (total:2,000m)
 - HRV air flow direction & air flow rate can be controlled
 - Expanded timer function

Specifications

Power supply	Single phase, 50 / 60 Hz, 220 – 240 V / 220 V
Power consumption	Max. 4.5 W
Forced ON / OFF input	Continuous "a" contact Contact current: approximately 10 mA
Size	180 (W) x 120 (H) x 64.5 (D)
Weight	430 g

(Unit: mm)

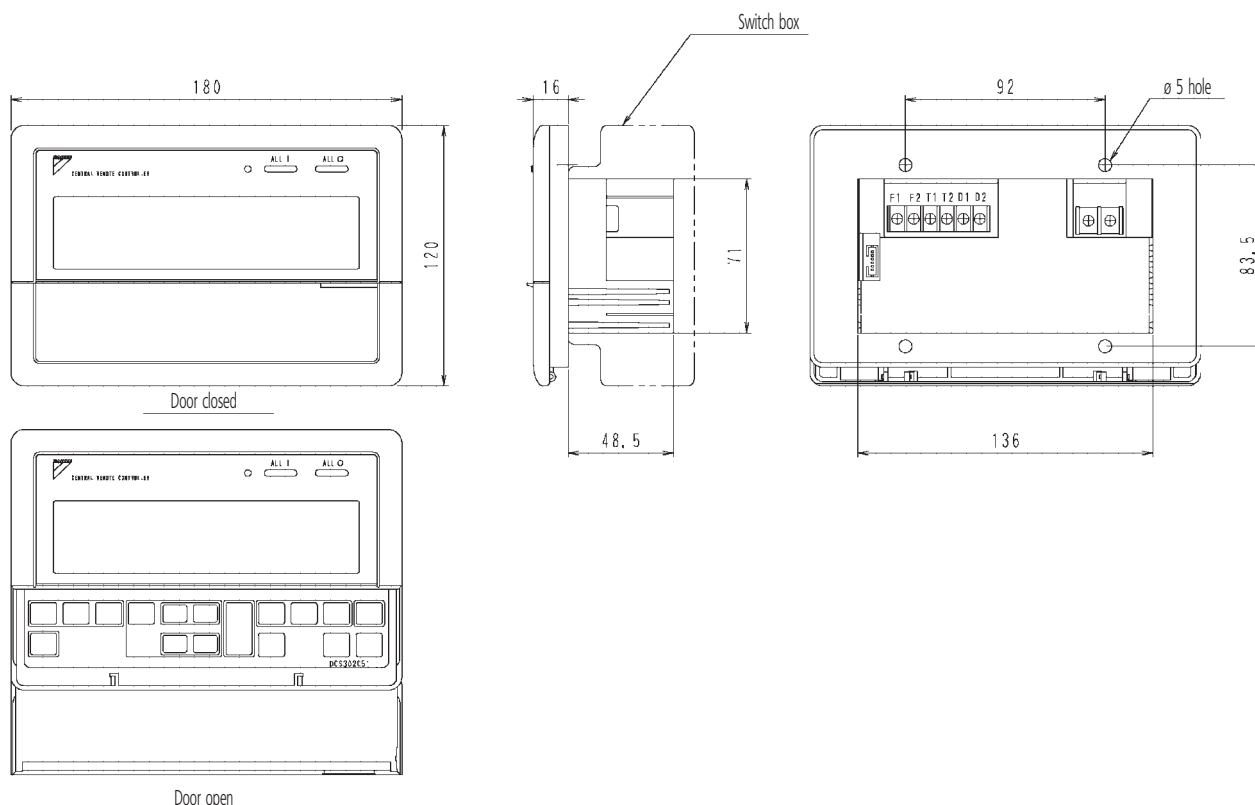

DCS302C61



SPECIFICATIONS

■ Specifications

Power supply	1 ~ 50/60Hz, 100V - 240V
Power consumption	Max. 8W
Forced ON/OFF input	Continuous "a" contact Contact current: approximately 10mA
Size	180 (W) × 120 (H) × 64.5 (D)
Weight	420g

■ Outline drawings

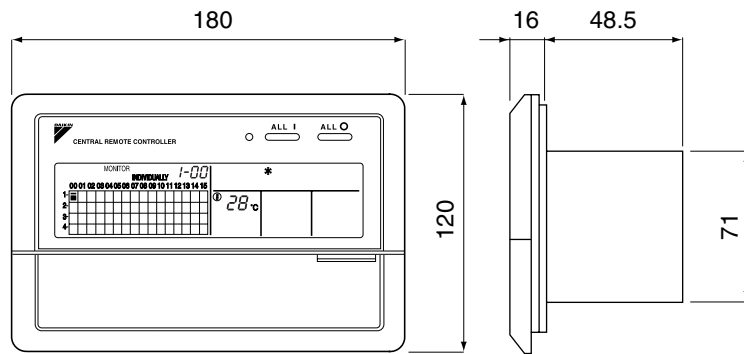

When using this unit an electric parts box of KJB311A is required.
For installation, a steel electric parts box to be embedded is mandatory.

DCS601C51 i-Manager

Main Features

Management

- Web application & internet compatibility
 - Monitoring & control according to user
 - Remote monitoring & control of more than one building
 - Remote monitoring & control of more than one building via internet
- Power Proportional Distribution: PPD (option)
- Easy management of electricity consumption
- Enhanced history function

Control

- Individual control (set point, start/stop, fan speed, etc) (Max. 2 x 64 groups/indoor units)
- Enhanced scheduling function (8 schedules, 17 patterns)
- Yearly schedule
- Flexible grouping in zones
- Automatic cooling/heating changeover
- Temperature limit
- Heating optimization
- Fire emergency stop control
- Interlocking control (option)
- Increased HRV monitoring and control function
- Password security: 3 levels (general, administration & service)
- Quick selection & full control
- Simple navigation

Open Interface

- Communication to any third party controller (domotics, BMS, etc.) is possible via open interface

Monitoring

- Visualisation via Graphical User Interface (GUI)
- Icon colour display change function
- Indoor units operation mode
- Error messages via e-mail (option)
- Indication filter replacement
- Multi PC

Cost Performance

- Labour saving
- Easy installation
- Compact design: limited installation space
- Overall energy saving

Connectable to

- VRV
- HRV
- Sky Air (via interface adapter)
- Split (via interface adapter)

System Layout

- Up to 2 x 64 indoor units can be controlled
- Onboard Ethernet port (web + e-mail)
- Digital i/o contacts (option)
- Touch panel (full colour LCD via icon display)

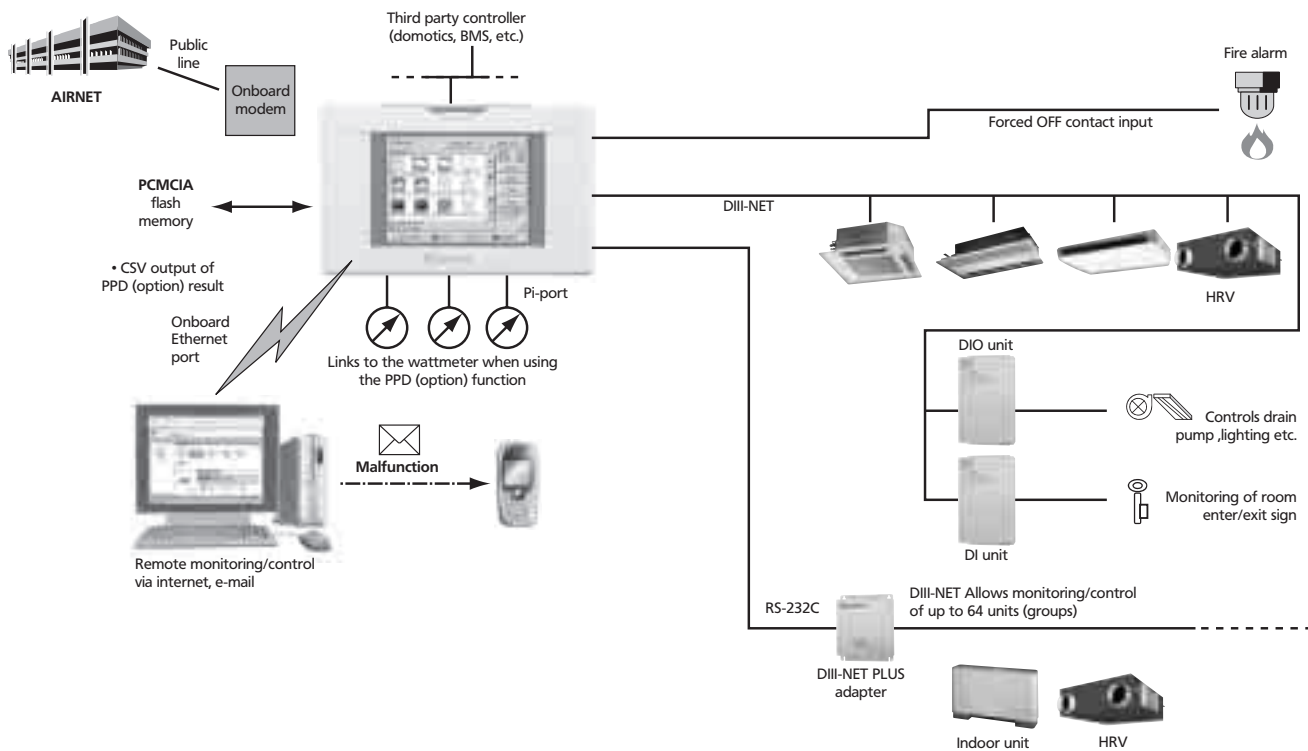

DCS601C51 i-Manager

Specifications



		Intelligent Touch Controller
REFERENCE	DCS601C51	
POWER SUPPLY	externally supplied AC100V-240V, 50/60Hz	
CONDITION OF INSTALLATION METHOD FOR USE	JIS4 switchbox embedded in indoor wall	
OPERATING CONDITION	Surrounding temperature	0°C to 40°C
	Humidity	less than 85 % RH (if no condensation)
DIMENSIONS	HxWxD	mm
LCD PANEL	Size / n° of dots / n° of colours	5.7 inches / QVGA 320x240 / 4,096 colours
MAXIMUM NUMBER OF INDOOR UNITS	1 x 64 (2 x 64: combined with DCS601A52)	
MAXIMUM NUMBER OF OUTDOOR UNITS	1 x 10 (2 x 10: combined with DCS601A52)	
PC & DISPLAY	built-in	
INPUT	Touch panel	10 bit encoded analog input
COMMUNICATION FUNCTIONS	DIII-NET x 1	air conditioning equipment communication line
	Ethernet	1 port for internet
	RS-232C	DIII-NET Plus adapter
	10BASE-T	web option
	Modem	built-in modem for airmet
	PCMCIA slot	flash memory card
INPUT TERMINALS	Digital input Di x 1	forced shutdown
	Pulse input Pi x 3	power measuring pulse
OVERSEAS CERTIFICATION	Safety of information - Technology Equipment	IEC60730 (including IEC60335)
	Interference (EMC)	EN55022 Class A, EN55024
PROJECT DATA & ENGINEERING	Configuration and engineering for each project are necessary. For further details, please consult with Daikin distributors and dealers	

Dimensions

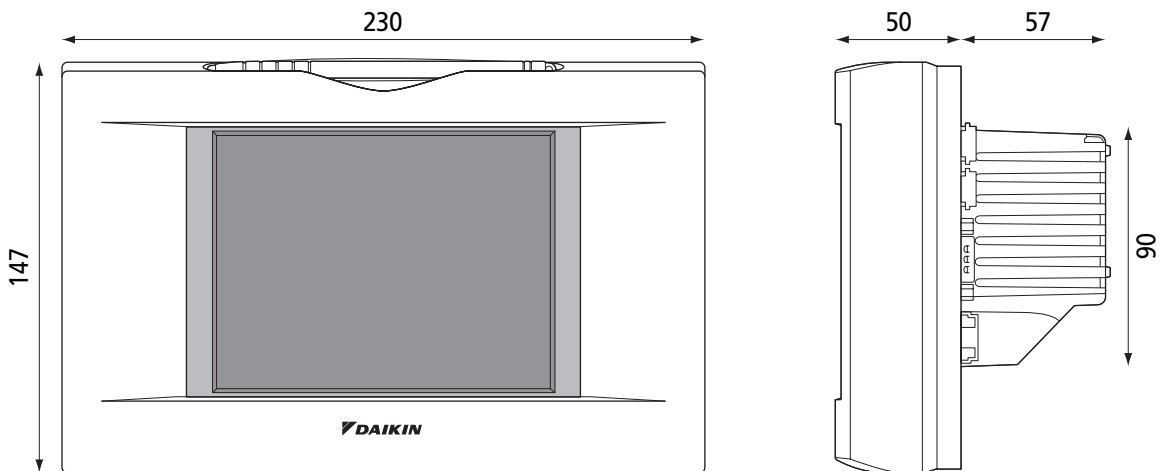

DEC101A51 Digital input (Input contacts: 16 points)

Dimensional drawing

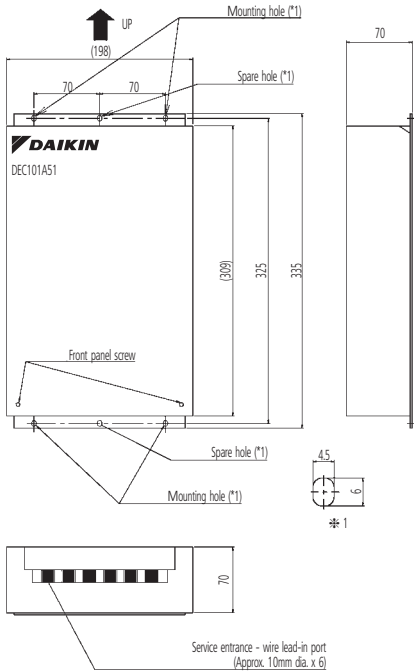

Power supply specifications	1~200-240V 50/60Hz
Rated power consumption	15W
Mass (Weight)	2.5kg
Case material	Plated steel sheet
Case color	Matting chrome

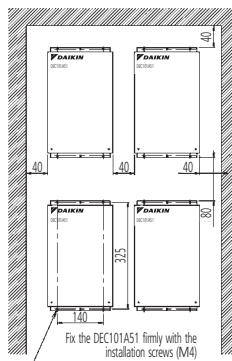

NOTES

- Installation place

 - Install the unit indoors where it is not exposed to water and dust or dirt.
 - Install the unit where both temperature and humidity do not become high.
(Operating (available) temperature: -10~+40°C
Operating (available) humidity: 10~85%)
 - Connect the wiring to be connected in the field from the lower surface side.
It is, therefore, necessary to make arrangements so as not to attach other equipment within 80mm from the lower surface of this equipment.
 - Install this equipment in a place in which only authorized personnel can touch it.
- Installation Direction

Install this equipment vertically to the floor surface. It should be noted that if it is installed in horizontal direction, a malfunction or failure may result.
- Installation Method

Ensure that this equipment is installed with 4 screws (screw size M4 min.).
- Restrictions in continuous installation

In case several devices are set up and installation inside the power board is carried out, each equipment installation space and space between the wall surface and this equipment should be left at least as shown to the left.

DEC102A51 Digital input (Input contacts: 8 points; output contacts: 4 points)

Dimensional drawing

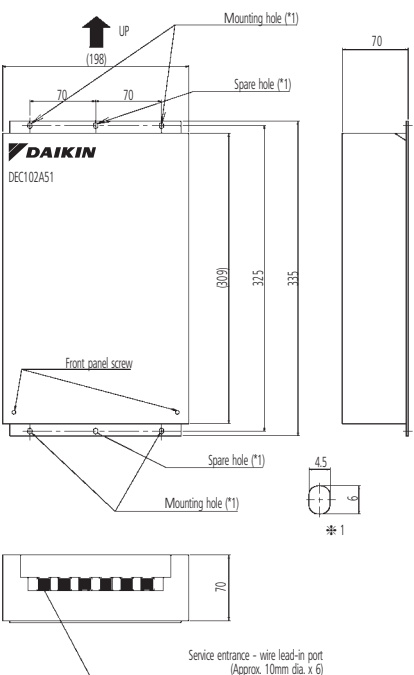

Power supply specifications	1~200-240V 50/60Hz
Rated power consumption	15W
Mass (Weight)	2.5kg
Case material	Plated steel sheet
Case color	Matting chrome

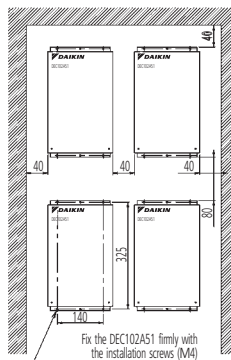

NOTES

- Installation place

 - Install the unit indoors where it is not exposed to water and dust or dirt.
 - Install the unit where both temperature and humidity do not become high.
(Operating (available) temperature: -10~+40°C
Operating (available) humidity: 10~85%)
 - Connect the wiring to be connected in the field from the lower surface side.
It is, therefore, necessary to make arrangements so as not to attach other equipment within 80mm from the lower surface of this equipment.
 - Install this equipment in a place in which only authorized personnel can touch it.
- Installation Direction

Install this equipment vertically to the floor surface. It should be noted that if it is installed in horizontal direction, a malfunction or failure may result.
- Installation Method

Ensure that this equipment is installed with 4 screws (screw size M4 min.).
- Restrictions in continuous installation

In case several devices are set up and installation inside the power board is carried out, each equipment installation space and space between the wall surface and this equipment should be left at least as shown to the left.

DMS502A51 BACnet Gateway

Outline and Features

1. Managing the information on 64 groups of air-conditioners (main units only).
2. Up to 256 groups manageable and controllable at once by adding the optional DIII board.
3. Packaging of air-conditioner objects
 - * Compatible with BACnet (ANSI/ASHRAE-135)
 - * Compatible with BACnet/IP (ANSI/ASHRAE-135a)
 - * Compatible with IEIEJ/p-0003-2000 (plan)
(IEIEJ is Institute of Electrical Installation Engineers of Japan)
4. Conforming to European, Oceanian, Safety and EMC rules and regulations.

System Outline

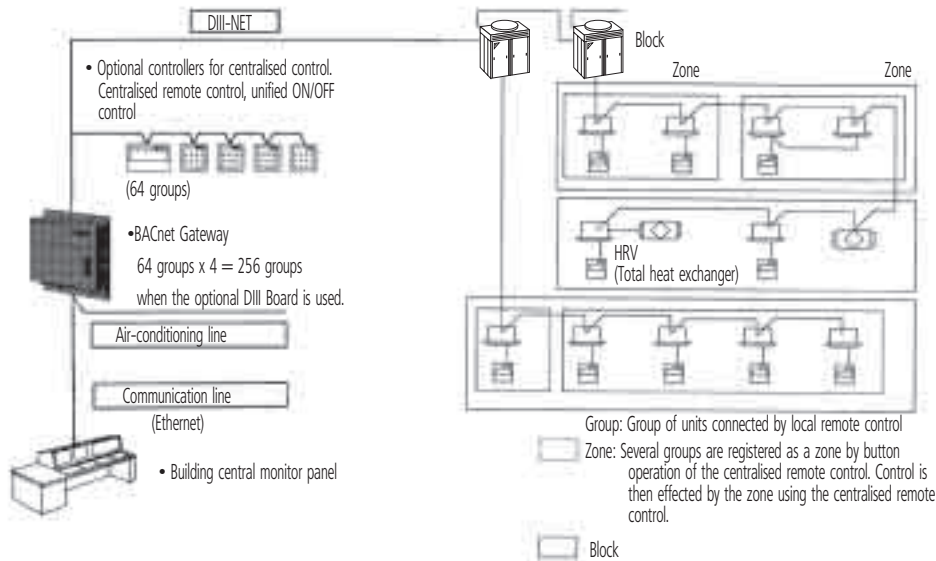

Name	Functions
BACnet Gateway (DMS502A51)	Interface unit to allow communications between VRV and BMS. BMS ready to run and monitor the air-conditioning systems through BACnet communications. Up to 64 groups.
Optional DIII board (DAM411B51)	Expansion kit, installed on the BACnet Gateway (DMS502A51), to provide 3 more DIII-NET communication ports. Not usable independently. Up to 256 groups.

NOTES

- 1 A group consists of several indoor units that can be started or stopped simultaneously. As shown in the figure above, a group consists of several indoor units wired to the same remote control. For units without remote control, each unit is treated as a group.
 - 2 Several groups are registered as a zone with the centralised remote control. By pushing 1 button of the centralised remote control, all groups within the same zone can be turned on or off simultaneously.
- Building management 1 system controls and monitors air-conditioning equipment by the block. A block consists of 1 or more groups (max. 16), and can be set without regard for the zones mentioned above. You must, how-ever, take the following things into consideration:
- 3 If the air-conditioning mode is switched, as a premise, permission for cool/heat selection for indoor units (by remote controller or central remote controller) must be designated within the program.
 - 4 Program status is basically monitored by observing the data of a representative unit. The contents which can be monitored are therefore restricted if the representative unit is designated as an adaptor, etc.
- Block registration is accomplished through signal transmission from the building control system to the cooler-conditioning system. Because configuration can be changed while receiving power even after operating, maintenance from the maker of the air-conditioning equipment is not required when changing the configuration.

Accessories

Item		Description
DIII board	DAM411B51	Extension of 3 x DIII lines (3 x 64) indoor units
Digital input /output	DAM412B51	For forced shutdown
Interface adapters	KRP928A2S	For connection to Split units
	DTA102A52	For connection to R-22/R-407C Sky Air units
	DTA112B51	For connection to R-410A Sky Air units

DMS502A51 BACnet Gateway

Specifications

Item	Description	
Rated Electrical conditions	Rated Voltage and Frequency	Single Phase AC 200-240, 50/60 Hz
	Rated Power	Maximum 20 W
Conditions for Use	Power Supply Fluctuation	±10% of the Rated Value
	Ambient Temperature	-10~+50°C
	Ambient Humidity	0~98° (Sweating is not acceptable)
	Preservation Temperature	-20~+60°C
Performance	Insulation Resistance	50MΩ or more by DC500 megohmmeter
Mass		4.0 kg
Colour of the Unit	Unit	PANTONE 533C
	Letter	PANTONE 656C
	Lines	PANTONE 656C

Components

The following parts are attached to this unit. Make sure to check them before installation.

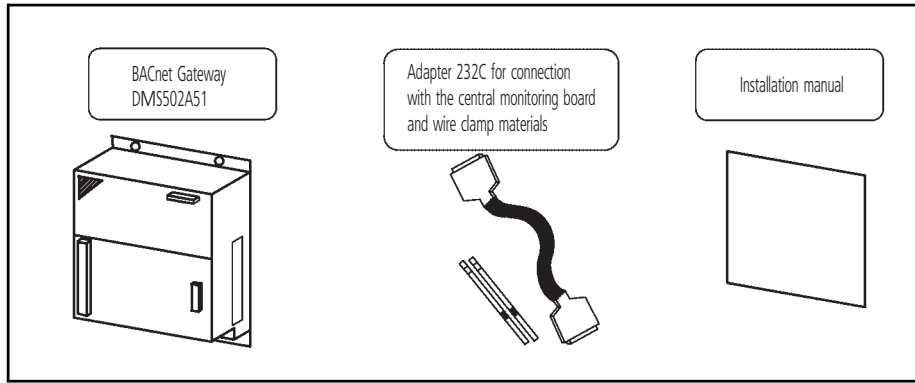

Dimensions

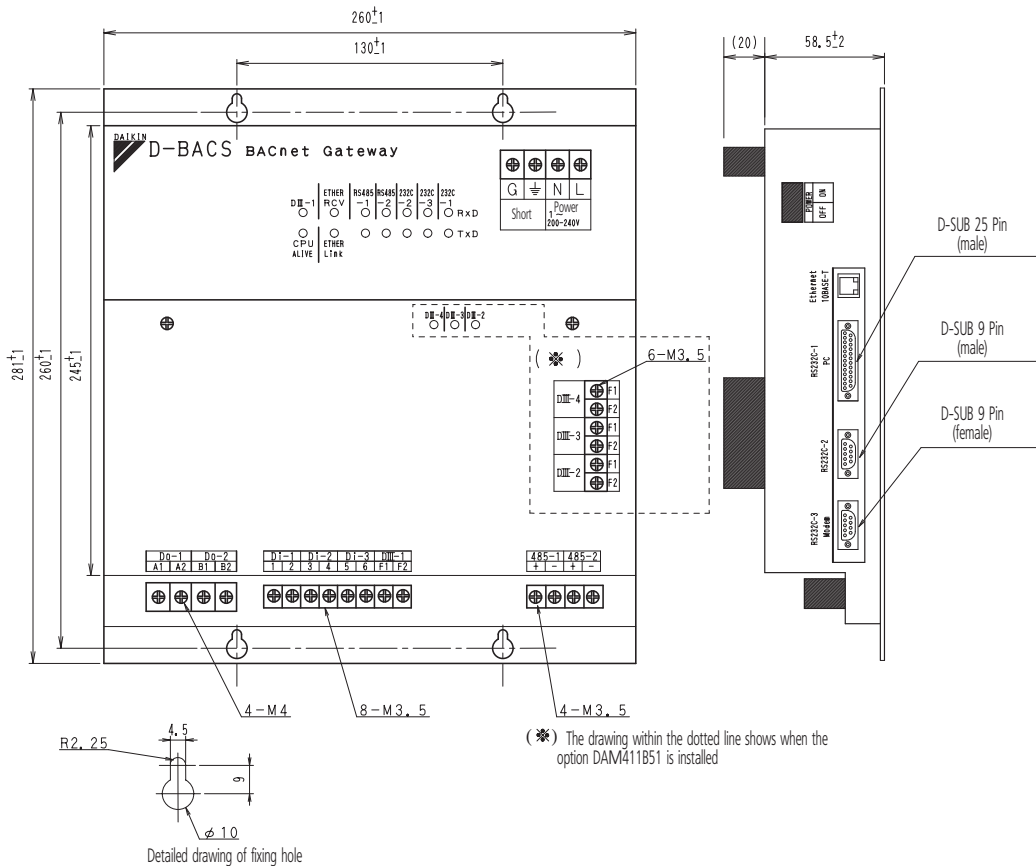

DMS504B51 LonWorks networks compatible gateway

Specifications

Item	Specifications	
MODEL	DMS504B1	
DIMENSIONS	mm	168 (W) x 260 (H) x 50 (D) mm
WEIGHT	kg	1.5 kg
POWER SUPPLY	Single phase AC100V 50/60Hz	
POWER CONSUMPTION	Max. 5W	
OPERATION RANGE	-10 to 50 °C	
STORAGE TEMPERATURE RANGE	-20 to 60 °C	
HUMIDITY	Up to 95% (no condensation)	
PROTOCOL	LonTalk®	
TRANSMISSION SPEED	78Kbps	
INSTALLATION	Mounted to indoor distribution board	
TOPOLOGY	FTT-10A (Free topology)	
TRANSMISSION MEDIUM	Twisted pair wire	
CONTACT INPUT	Forced OFF x 1 (A/Cs en bloc)	

Dimensional drawing

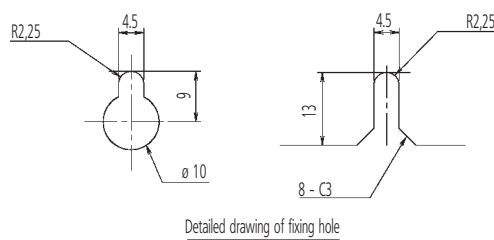
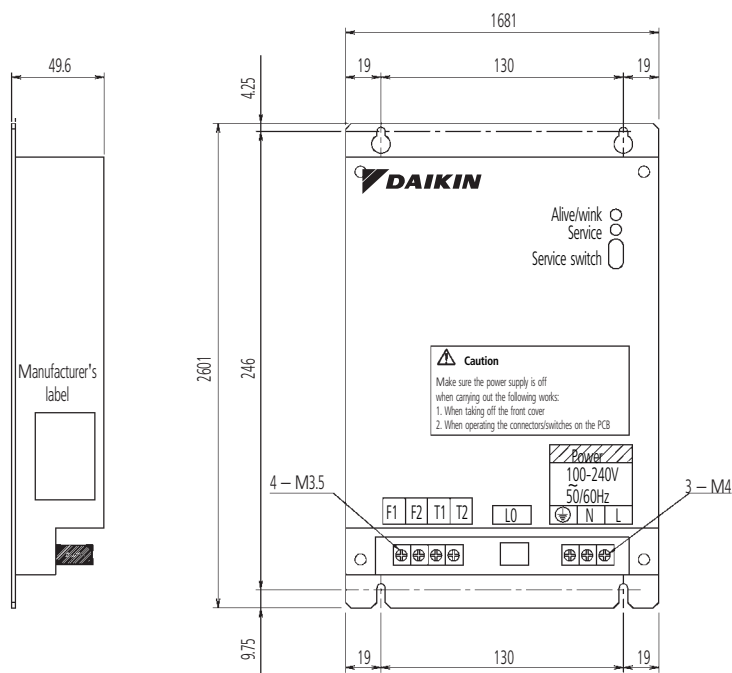

NOTES

- Rated electrical conditions:
Rated voltage and frequency: single phase AC100~240V 50/60Hz
Rated power: Maximu 5W
- Conditions
Power Supply fluctuation: ±10% of the rated value
Ambient temperature: -10~+50°C
Ambient humidity: 0~95% (Sweating is not acceptable)
Preservation: -20~+60°C
- Performance Insulation resistance: 50MΩ or more by DC500 megohmeter
- Weight: 1.5 kg

DST301B51 - Schedule timer



Enabling 64 groups to be programmed.

- A maximum of 128 indoor units can be controlled
- 8 types of weekly schedule
- A maximum of 48 hours back up power supply
- A maximum wiring length of 1,000m (total:2,000m)

(Unit: mm)

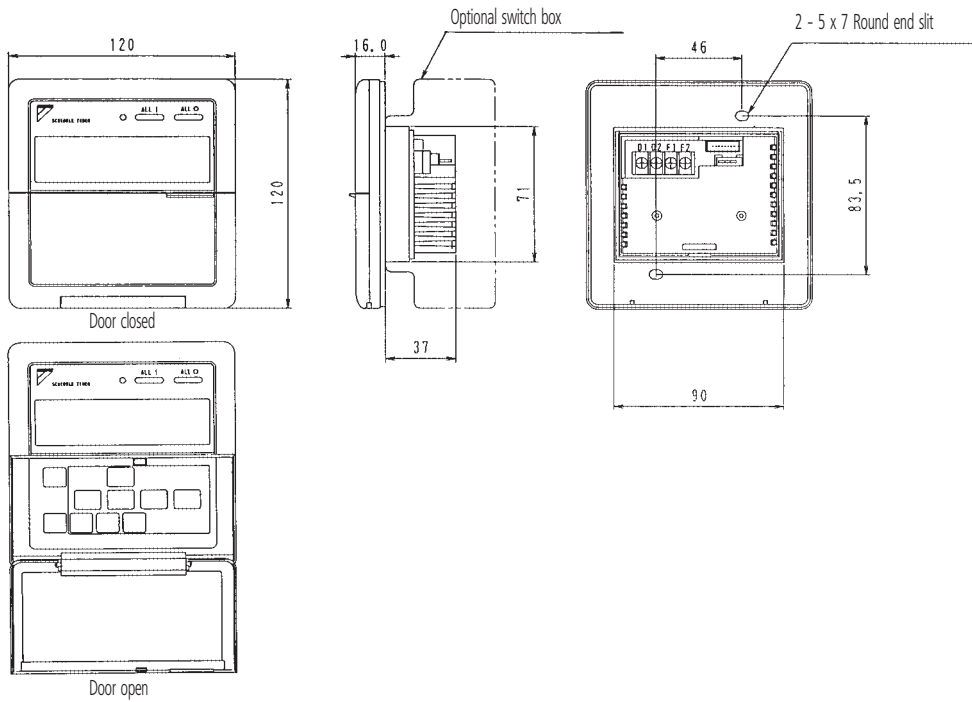

DTA102A52 - Interface adapter for Sky Air Series

Outline / Features

This is an interface adapter required for all Sky Air for "F" type to the subsequent models to connect to the central control equipment (Centralised remote control, Unified ON/OFF controller and Schedule timer), and by combining with the central control equipment, you can set the control mode, such as unified ON/OFF control, timer operation, rejection/acceptance by remote controller operation and etc., and also display the operating status.

Applied Model

All the series of Sky Air from "F" type to the subsequent models and Packaged Air Conditioner FDYB.

But, Interface adapter for Sky Air series (old type) is used for Sky Air series "C(D)" type.

System Configuration

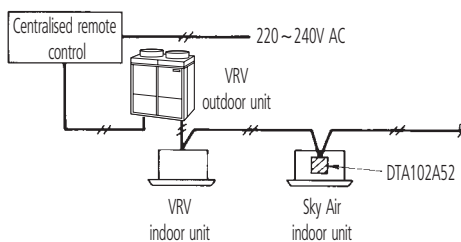

Description of Functions

A. Control functions

By using this adapter, you can control or monitor the following function from the central control equipment.

	Description of functions
1. ON/OFF operation	Turns indoor unit ON or OFF.
2. Operation/malfunction monitoring	Monitors operation or error status
3. Cool/heat changeover	
4. Temperature setting	Temperature setting is possible within the temperature setting range of Sky Air (20 ~ 35°C for cooling and 15 ~ 30°C for heating).
5. Control mode setting for remote controller	Restricts remote controller operation for ON/OFF control, cool/heat changeover and temperature setting. (Last command priority/Remote Control Rejection and etc.)
6. Test operation	Operates the indoor units by Forced thermostat "ON".
7. Malfunction code display and reset	
8. Group control	Controls up to 16 indoor units simultaneously.
9. Room temperature monitoring	Monitors room temperature if connected to the Parallel interface or the Data station.
10. Forced thermostat "OFF"	If the central controller is equipped with the forced thermostat OFF function, it switches the Sky Air to "FAN" operation.
11. Filter sign display and reset	
12. Air flow direction and air flow rate setting	Possible to change the setting by the individual setting mode of the centralised remote control. (Note 1)
13. Various monitoring function	Thermostat status, Compressor operation status, Indoor fan operation status, Auxiliary electric heater operation status. (Note 2)

NOTES

- 1 The central control equipment should be installed in the system
- 2 This is possible only when connected to the Data station and monitored by central monitoring panel

B. Not controllable functions

This adapter is not corresponding to the following functions.

	Description of functions
1. Energy saving command	Set-back the setting temperature by 2°C. (thermostat "OFF" operation)
2. Low operating noise command	Lowering the operating noise by reducing the capacity
3. Demand control	Controls the power consumption by reducing the capacity

DTA104A61 • 62 - External control adapter for outdoor unit

Outline / Features

By installing this adapter in the indoor unit of VRV series or BS unit connected to DIII-NET (or outdoor unit in case of VRV plus series or VRV inverter "K" series), it enables you to have individual/simultaneous cool/heat changeover of several outdoor units connected, demand control and low noise control.

NOTE

- 1 Demand control and low noise control is possible only for VRV plus series and VRV inverter "K" series.

Applied Model

The type of adapter differs depending on the model of indoor unit.

	Applied adapter
FXCQ • FXKQ • FXSQ • FXBQ • FXMQ • FXAQ • FXLQ • FXNQ	DTA104A61
FXFQ • FXHQ	DTA104A62

The adapter can also be installed in the outdoor unit of VRV PLUS series and VRV inverter "K" series.

System Configuration

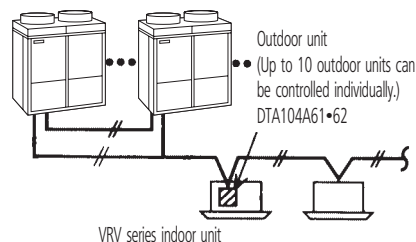

Description of Functions

1. Control functions

By using an external control adapter for outdoor units, it enables the following controls. However, these functions are of adapter itself and the type of adapter differs depending on the model of indoor unit and BS unit to be installed.

1. Unified changeover of Cool/Heat mode

- To change the cool/heat mode of several outdoor units by one remote controller
- To changes the cool/heat mode of outdoor units by cool/heat centralised remote control or cool/heat remote controller.

2. Demand control

- When short circuit between (1) and (C) : Approx. 70%
- When short circuit between (2) and (C) : Approx. 40%
- When short circuit between adapter terminals (3) and (C) : Forced fan operation (The percentage indicates the ratio of power consumption.)

3. Low noise control

By controlling the capacity of outdoor unit, it reduces the operating noise by 2~3dB.

2. Instruction for installation

- For VRV plus series and VRV inverter "K" series, it is possible to switch cool/heat simultaneously only by remote controller for indoor unit or cool/heat centralised remote control
- This adapter enables to have demand control and low noise control only for VRV plus series and VRV inverter "K" series.

DTA109A51 DIII-Net expander adapter

Outline / Features

This adapter is intended for increasing the number of indoor units under control. The scalable device helps extend from the existing 128 indoor units up to 1,024 indoor units (in 64 groups under a central controller).

Applied Model

All VRV series models (after Type K)



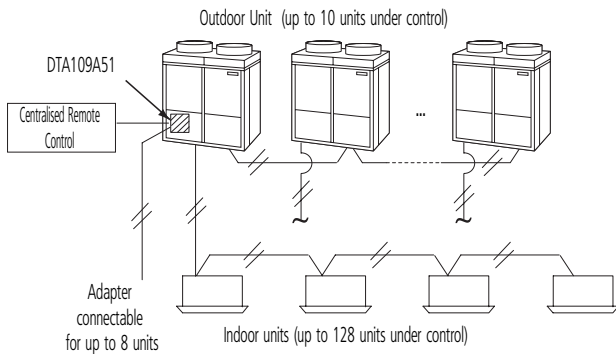



System Configuration



DTA112B51 Interface adapter for connection to R-410A sky air units

Accessories

Check if the following accessories are included in the kit.

① Adapter	② Relay PCB	③ Relay harness	④ PC board support	⑤ Clamp material	⑥ Installation manual
 x1	 x1 (for model other than FFQ)	 x1 (for FFQ model)	 x4	 x2	 x1

NOTE

Before opening control box lid, be sure cut off the all air conditioner power of indoor unit and outdoor unit, or you may get an electrical shock.

System outline

- By connecting this kit to an optional controller for centralized control, all units of the SKY AIR Series in the system can be controlled as a group from the optional controller.
- One kit must be installed onto the master unit of each group.

DTA113B51 DSnet

Features & Outline

The ideal solution for control and management up to 2,000 indoor units

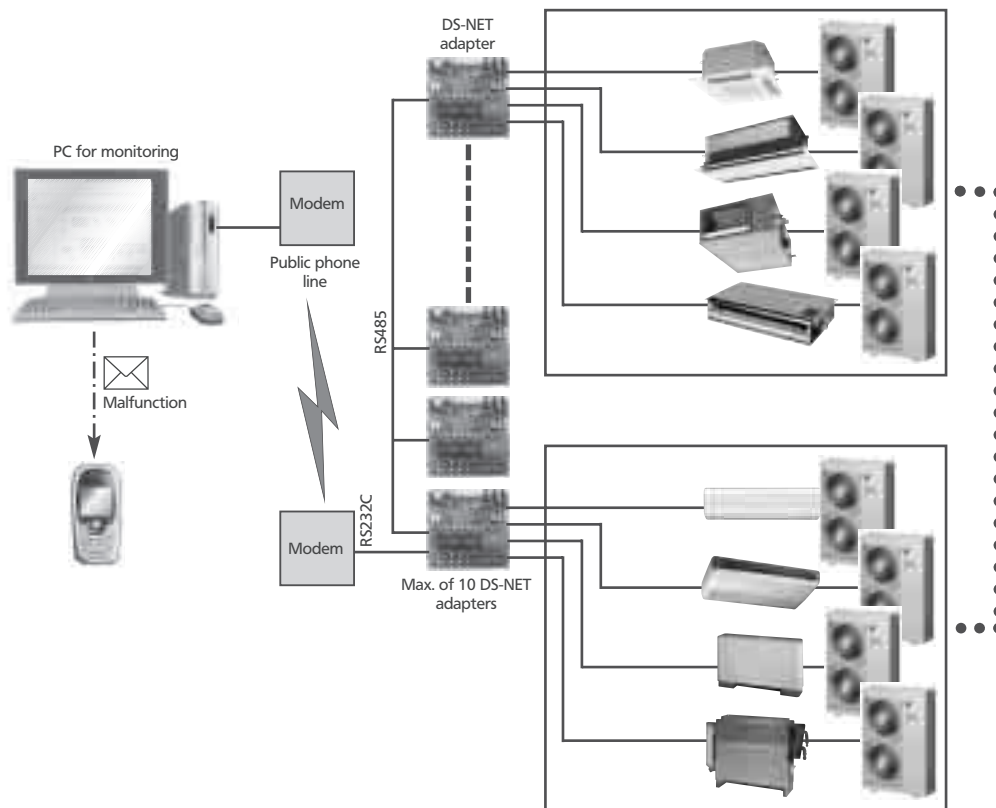

Application area

- A small commercial area of less than 40 indoor units.
- Critical applications for centralized monitoring.

System layout

- Allows monitoring and control of up to up to 50 stores or sites and 2,000 indoor units with just one modem and phone line.
- Automates daily air conditioning operation in order to free users from the hassle of air conditioning operation/management.
- The daily schedule setting allows automatic operation afterward.
- Automates alarm (report messages) for any malfunctions/ errors. Immediate report of any indoor unit breakdown to the servicing company.
- Automatic report of breakdown/ malfunction information.
- Minimizes the inconvenience of not having air conditioning via rapid messages.

Functions

- Schedule setup (Daily schedule)
 - Start/Stop
- A/C malfunction report
 - Send message to monitoring system
- Manual operation
 - Start/Stop, Set temperature, Operation mode, Fan speed
- Status monitoring (Start/Stop, Set temperature, Operation mode, Room temperature, Operation time, Error code)

NOTES

- DS-net can also be controlled via your mobile phone.

EKEXDCBA - EKEXFCBA - Option kit for combination of Daikin condensing units with field supplied evaporators

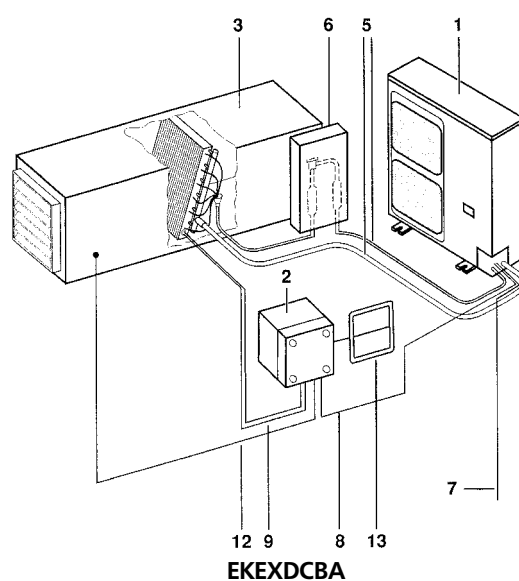
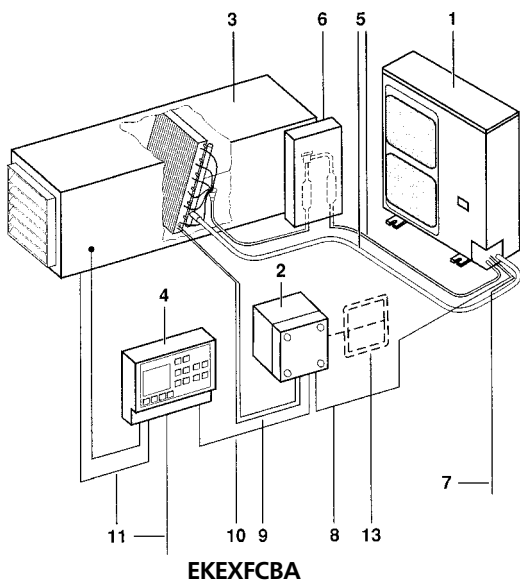

Name and function of parts

Parts and components

- 1 Outdoor unit
- 2 Control box (EKEXFCBA / EKEXDCBA)
- 3 Air handling unit (field supply)
- 4 Controller (field supply)
- 5 Field piping (field supply)
- 6 Expansion valve kit

Wiring connections

- 7 Outdoor unit power supply
- 8 Control box wiring (Power supply and communication between control box and outdoor unit)
- 9 Evaporator thermistors
- 10 Communication between controller and control box
- 11 Power supply and control wiring for evaporator (air handling unit) and controller (power supply is separate from the outdoor unit)
- 12 Air thermistor control for evaporator (air handling unit)
- 13 Remote control (----- = for service only)

Installation

Accessories

		EKEXFCBA	EKEXDCBA
Thermistor (R1T)		-	1
Thermistor (R3T/R2T) (2.5m cable)			2
Insulation sheet			2
Rubber sheet			2
Wir to wire splice		4	6
Installation and operation manual			1
Screw nut		6	8
Tie wrap			6
Capacity setting adapter			7
Stopper (closing cup)		2	-

Obligatory accessory

	EKEXFCBA	EKEXDCBA
Expansion valve kit		EKEXV

Refer to chapter "Valve kit installation" on page 3 for installation instructions.

Optional accessories

	EKEXFCBA	EKEXDCBA
Remote control		1(*)

(*) Not required for operation, only useful accessory tool for service and installation.

EKEXV - Air handling unit connection - Expansion kit

Specifications

TECHNICAL SPECIFICATIONS				EKEXV63	EKEXV80	EKEXV100	EKEXV125	EKEXV140	EKEXV200	EKEXV250
Casing	Colour			Ivory White						
	Material			Metal						
Dimensions	Unit	Height	mm	401	401	401	401	401	401	401
		Width	mm	215	215	215	215	215	215	215
		Depth	mm	78	78	78	78	78	78	78
	Packing	Height	mm	457	457	457	457	457	457	457
		Width	mm	270	270	270	270	270	270	270
		Depth	mm	120	120	120	120	120	120	120
Weight	Unit		kg	2.9	2.9	2.9	2.9	2.9	2.9	2.9
	Packed Unit		kg	3.4	3.4	3.4	3.4	3.4	3.4	3.4
Operation Range	Cooling	Min	°CDB	5.0	-5.0	-5.0	-5.0	-5.0	-5.0	-5.0
		Max	°CDB	46.0	46.0	46.0	46.0	46.0	46.0	46.0
Sound Level (nominal)	Sound pressure		dBA	45.0	45.0	45.0	45.0	45.0	45.0	45.0
Piping connections	Liquid (OD)	Type		Braze connection						
		Diameter (OD)	mm	9.52	9.52	9.52	9.52	9.52	9.52	9.52
	Piping Length			see manual, depend on the outdoor unit						
	Installation height difference	Maximum	m	see manual, depend on the outdoor unit						
	Max. internunit level difference		m	see manual, depend on the outdoor unit						
	Heat Insulation			Both inlet and outlet						
Notes				The sound pressure value is the maximum value measured at 10cm from the motor.						

EKEXV
Dimensional drawing

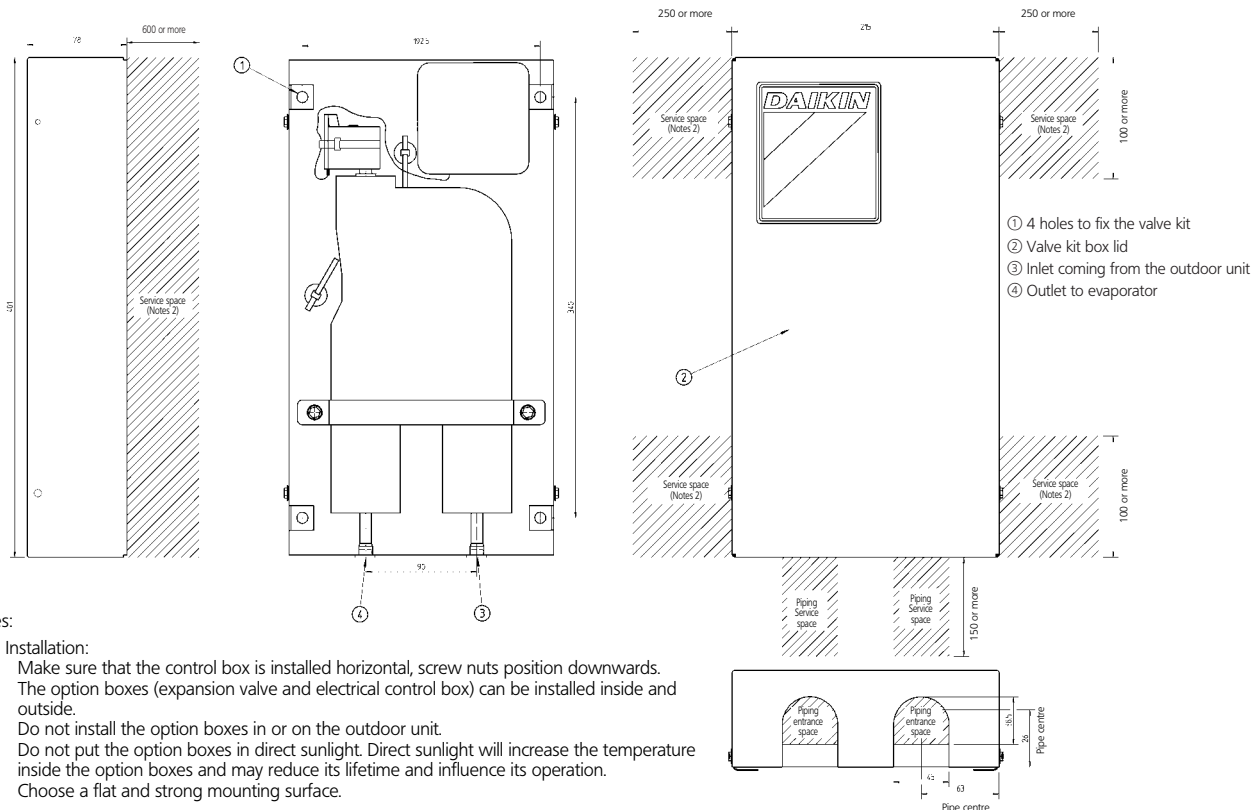

Notes:

- Installation:**
Make sure that the control box is installed horizontal, screw nuts position downwards.
The option boxes (expansion valve and electrical control box) can be installed inside and outside.
Do not install the option boxes in or on the outdoor unit.
Do not put the option boxes in direct sunlight. Direct sunlight will increase the temperature inside the option boxes and may reduce its lifetime and influence its operation.
Choose a flat and strong mounting surface.
- Service space:**
Keep enough free for future maintenance.

EKRORO - Remote ON/OFF

SPECIFICATIONS EKRORO

Wire specifications

Operating method

Input	X40A Switch	ON*	
		OFF	
Remote control	ON		
	OFF		
Unit	Standard setting: "forced off"	ON	
		OFF	
	Alternative setting: "on/off"	ON	
		OFF	

* Input "ON" : closed contact.

Forced off		on/off operation	
Input "on" stops operation + disables control	Input "off" enables control	Input of - on: starts operation, remote control is still enabled.	Input on - off: stops operation, remote control is still enabled.

Selection of "forced off" and "on/off" operation

Setting	Mode No.	First code No.	Second code No.
Forced off	12 (22)	1	01
On/Off operation			02

EKR1B2 - Electric heater PCB kit

Content of kit

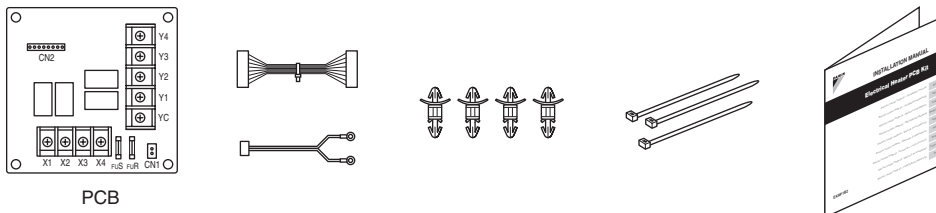

Name of parts

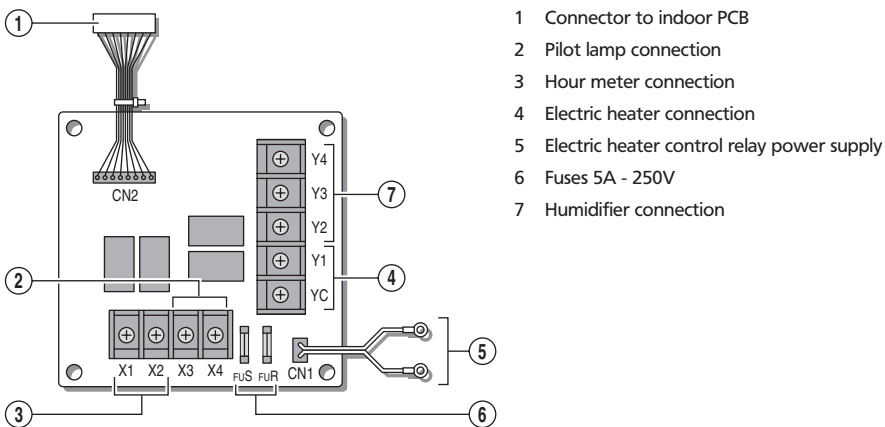

KAC972A4E - Pleated filter

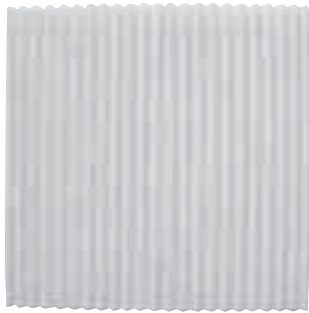

Dimensions

Unit: mm

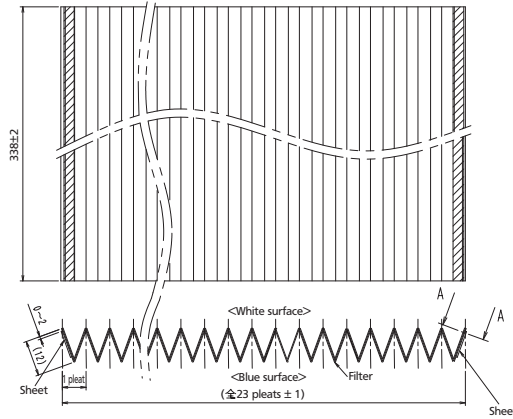

KAF495FA140 - Long life replacement filter

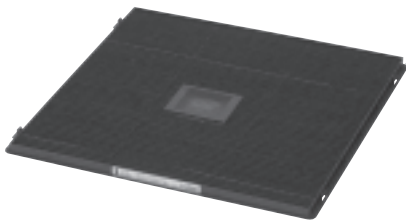

- Can be water-washed. Can be reused.

Dimensions

Unit: mm

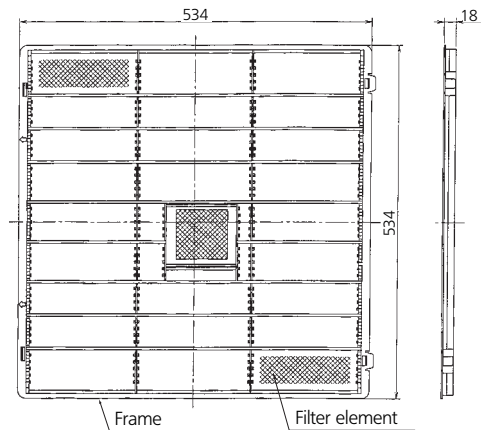

Item	Model	KAF495FA140
Conditions for use		Atmospheric temperature (0-60°C) Relative humidity (40-95%)
Initial pressure loss (Pa)		7 or less
Final pressure loss (Pa)		49 or less
Average efficiency (%)		50 (Gravity method)
Life (h)		2,500 (dust concentration 0.15 mg/m ³)
Fan strength passing through filter		18.5m ³ / min
Filter		Mildew-proof resin net
Required number of sheets		1
Weight (kg)		0.4

KAF918A43 (with Frame) KAF918A44 (without Frame) - Air purifying filter with photocatalytic deodorizing function



Item	Model	KAF918A43	KAF918A44
Function		Dust collection, Antibacteria, Antivirus	
Quantity		2	2
Dimensions (mm)	Width	229	216
	Height	63	51
	Thickness	8	5

KAF918A45 (with Frame) KAF918A46 (without Frame) - Air purifying - titanium apatite photocatalytic filter

KAF918A45 (with Frame)



KAF918A46 (without Frame)



Item	Model	KAF918A45	KAF918A46
Function		Dust collection, Antibacteria, Deodorization	
Quantity		2	2
Dimensions (mm)	Width	229	216
	Height	63	51
	Thickness	8	5

KAF925B41 (with Frame) · KAF925B42 (without Frame) - Air purifying filter

with Frame



without Frame



Item	Model	KAF925B41	KAF925B42
Function		Dust collection, Antibacterial, Antivirus	
Life Time		About 3 months	
Material		Polypropylene nonwoven (Antibacterial agent, antiviral, included)	
Color		Electrostatic Filter: white, Nonwoven cloth: Green, Fixed Net: Clearness	
Quantity		2 (1Time)	4 (2Times)
Dimensions (mm)	Width	230	215
	Height	63	50
	Thickness	8	7

KAF970A46 (without Frame) - Air purifying - titanium apatite photocatalytic filter



Item	Model	KAF970A46
Function		Dust collection, Antibacteria, Deodorization
Quantity		2
Dimensions (mm)	Width	255
	Height	42
	Thickness	5

KAF972A4E - Bio-antibody filter



Dimensions

Unit: mm

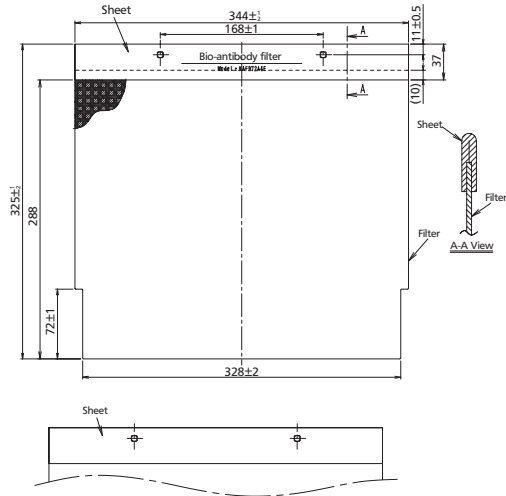

KAFJ252L36 · 56 · 80 · 160 KAFJ253L36 · 56 · 80 · 160 - High efficiency filter



Dimensions

Unit: mm

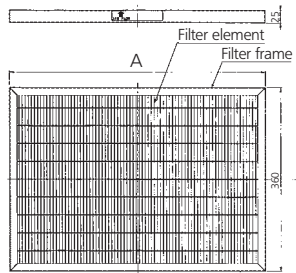

Model		A
KAFJ252L36	KAFJ253L36	500
KAFJ252L56	KAFJ253L56	650
KAFJ252L80	KAFJ253L80	448×1 502×1
KAFJ252L160	KAFJ253L160	698×1 652×1

- Cannot be water-washed for reuse.
- Below inlet:
The Filter Chamber (for High efficiency filter) (KAJ25L36D · 56D · 80D · 160D) is required when the high efficiency filter will be installed.
- Rear inlet:
The Filter Chamber (for High efficiency filter) (KAJ25L36B · 56B · 80B · 160B) is required when the high efficiency filter will be installed.

65 (colorimetric method)

Item	Model	KAFJ252L36	KAFJ252L56	KAFJ252L80	KAFJ252L160
Air flow rate (m ³ /min)		9	14	19	38
Average efficiency (%)		65 (colorimetric method)			
Initial pressure loss (Pa)		12 or less	14 or less	14 or less	22 or less
Final pressure loss (Pa)		98			
Life (h)		2,500 (dust concentration 0.15 mg/m ³)			
Filter		Flame-resistant type (with mildew-proof)			
Number of sheets included		1	1	2 (each 1)	2 (each 1)
Weight (kg)		0.5	0.6	0.9	1.2

90 (colorimetric method)

Item	Model	KAFJ253L36	KAFJ253L56	KAFJ253L80	KAFJ253L160
Air flow rate (m ³ /min)		9	14	19	38
Average efficiency (%)		90 (colorimetric method)			
Initial pressure loss (Pa)		21 or less	24 or less	24 or less	34 or less
Final pressure loss (Pa)		98			
Life (h)		1,800 (dust concentration 0.15 mg/m ³)			
Filter		Flame-resistant type (with mildew-proof)			
Number of sheets included		1	1	2 (each 1)	2 (each 1)
Weight (kg)		0.5	0.6	0.9	1.2

Installation

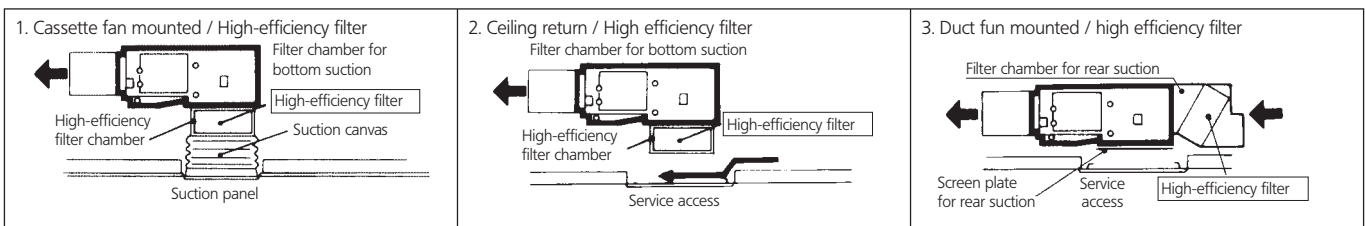

Note: • The filter chamber is required when the high efficiency filter will be installed.

KAFJ371L140 · 280 - High efficiency filter

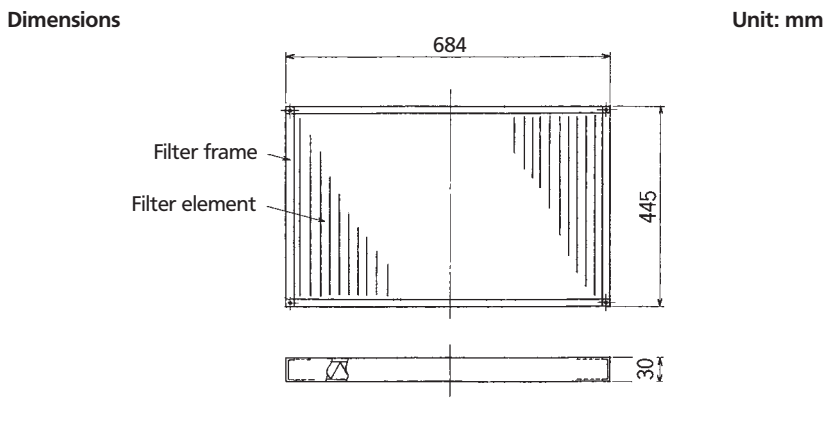
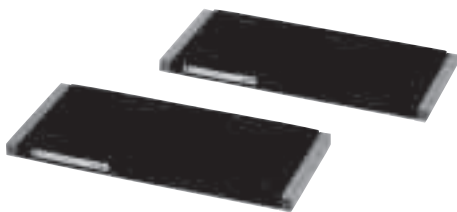

- Can be water-washed. Can be reused.
- The Filter chamber (KDJ3705L140 · 280) is required when the long life filter will be installed.

Item \ Model	KAFJ371L140	KAFJ371L280
Average efficiency (%)	50 (Gravity method)	
Initial pressure loss (Pa)	9.8 or less	
Final pressure loss (Pa)	49 or less	
Life (h)	2,500 (dust concentration 0.15 mg/m ³)	
Filter	Mildew-proof resin net	
Number of sheets included	1	2
Weight (kg)	1.4	1.4×2

KAFJ372L140 · 280 - KAFJ373L140 · 280 - High efficiency filter

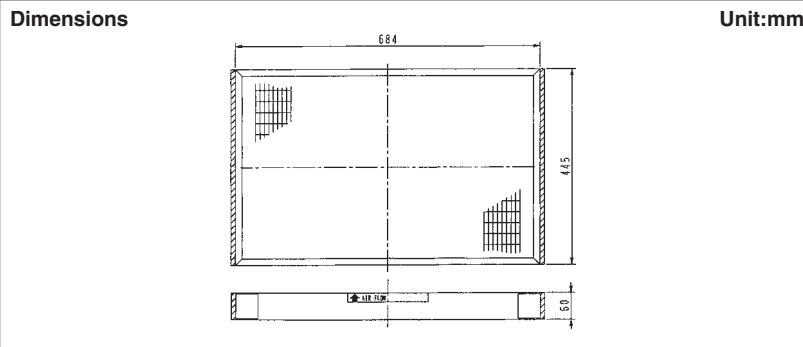

- Cannot be water-washed for reuse.
- The Filter Chamber (for high efficiency filter) (KDJ3705L140 · 280) is required when the high efficiency filter will be installed.

Item \ Model	KAFJ372L140	KAFJ372L280	KAFJ373L140	KAFJ373L280
Air flow rate (m ³ /min) / 1 sheet	36	40	36	40
Average efficiency (% · colorimetric method)	65	65	90	90
Initial pressure loss (Pa)	39	44	39	44
Final pressure loss (Pa)	98			
Life (h) *1	2,500	2,500	1,800	1,800
Filter element	Non-woven fabric			
Number of sheets included	1	2	1	2
Mass (kg)	1.0	2.0	1.0	2.0

Note
*1. Dust concentration 0.15 mg/m³

2

KAFJ501DA80, KAF501DA56/112/160 - Long life replacement filter

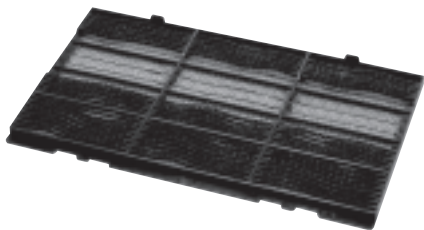

• Can be water-washed. Can be reused.

Dimensions

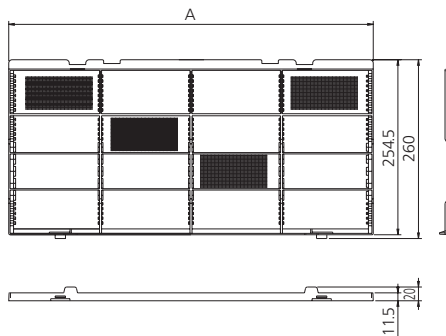

Unit: mm

Model	A
KAF501DA56	430
KAFJ501DA80	530
KAF501DA112	430
KAF501DA160	493

Item \ Model	KAF501DA56	KAFJ501DA80	KAF501DA112	KAF501DA160
Average efficiency (%)	45 (Gravity method)			
Initial pressure loss (Pa)	10			
Final pressure loss (Pa)	59			
Life (h)	2,500 (dust concentration 0.15 mg/m ³)			
Filter	Mildew-proof resin net			
Number of sheets included	2	2	3	3
Weight (kg)	0.3	0.4	0.5	0.6

KAFJ521F56,80 - Long life replacement filter

Specifications

	KAFJ521F56	KAFJ521F80
LIFE TIME, AVERAGE EFFICIENCY	2,500 hours (dust density 0.15 mg/m ³), 45% (gravity method)	
FILTER	mildew proof resin net	
REQUIRED QUANTITY	For 1 unit	2 pieces
APPLICABLE MODELS	25~40 class	63 class

Dimensions

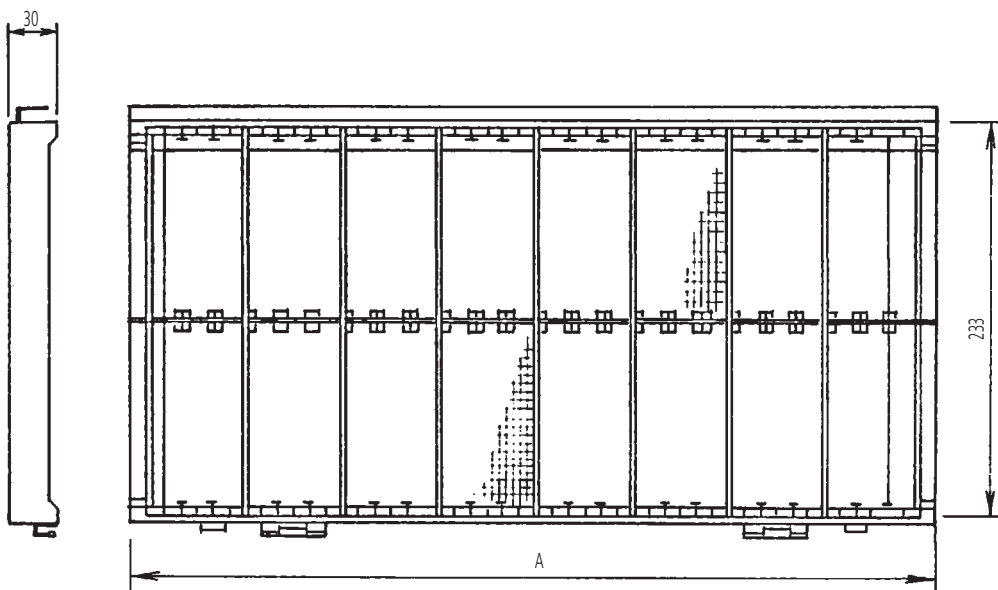

Model	A
KAFJ521F56	403
KAFJ521F80	503

KAJ25L36B · 56B · 80B · 160B - Filter chamber for rear suction



Dimensions

Unit: mm

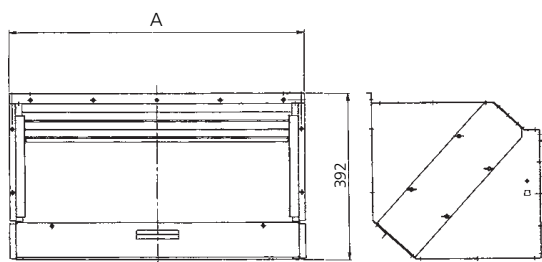

Model	A
KAJ25L36B	550
KAJ25L56B	700
KAJ25L80B	1,000
KAJ25L160B	1,400

- May be used with either the long-life filter or high-efficiency filter.
- The suction duct can also be connected.

		Model	KAJ25L36B	KAJ25L56B	KAJ25L80B	KAJ25L160B
Inner dimensions of flange (mm)	Width		470	620	920	1,320
	Length		250			
Inserted filter	65 (colorimetric method)		KAFJ252L36	KAFJ252L56	KAFJ252L80	KAFJ252L160
	90 (colorimetric method)		KAFJ253L36	KAFJ253L56	KAFJ253L80	KAFJ253L160
Weight (kg)			8.0	10.0	14.0	16.0
Component parts			Filter chamber, Screen plate for rear suction, Washer for suspension bracket, Screws, Installation manual			

KAJ25L36D · 56D · 80D · 160D - Filter chamber for bottom suction



Dimensions

Unit: mm

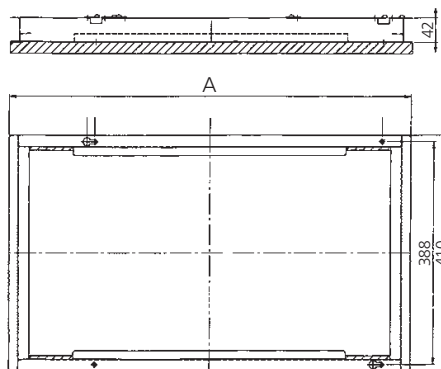

unit: (mm)

Model	A
KAJ25L36D	550
KAJ25L56D	700
KAJ25L80D	1,000
KAJ25L160D	1,400

- If there is not enough pitch in the drain pipe due to the attached cassette, this may be used as a spacer.
- Filter replacement is easily performed.

		Model	KAJ25L36D	KAJ25L56D	KAJ25L80D	KAJ25L160D
Inserted filter	65 (colorimetric method)		KAFJ252L36	KAFJ252L56	KAFJ252L80	KAFJ252L160
	90 (colorimetric method)		KAFJ253L36	KAFJ253L56	KAFJ253L80	KAFJ253L160
Weight (kg)			2.3	2.8	3.5	4.0
Component parts			Filter chamber, Panel attachment plate, Screws, Installation Manual			

KAZ917B41 (with Frame) · KAZ917B42 (without Frame) - Air purifying filter with photocatalytic function

with Frame

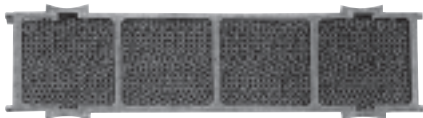

without Frame



Item	Model	KAZ917B41	KAZ917B42
Function		Antibacterial, Antivirus, deodorizer	
Frame		With Frame	Without Frame
Material		Honeycomb Structure Paper (Antivacterial agent, antiviral, deodorization, included)	
Color		Gray	
Quantity		2 (1Time)	
Dimensions (mm)	Width	216	
	Height	51	
	Thickness	5	

KDAJ25K36 · 56 · 71 · 140 - Air discharge adapter



- The “flexible duct” is required when the air discharge adaptor will be installed.
- Pre-insulated. Will not take up time on location.

Item	Model	KDAJ25K36	KDAJ25K56	KDAJ25K71	KDAJ25K140
Duct connection diameter		Ø200×1 port	Ø200×2 port		Ø200×4 port
Material		Steel plate	Resin		
Weight (kg)		1.1	1.0	1.6	2.3
Component parts		Air discharge adaptor, Screws (except KDAJ25K36), Installation manual			

Installation

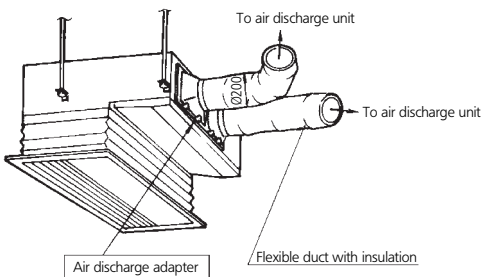

KDAJ25K36

Unit: mm

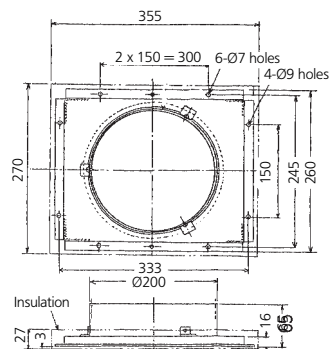

KDAJ25K56

Unit: mm

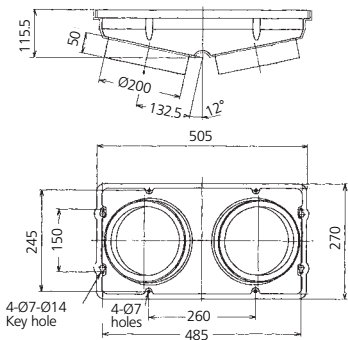

KDAJ25K71

Unit: mm

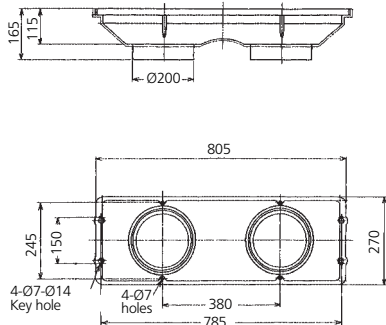

KDAJ25K140

Unit: mm

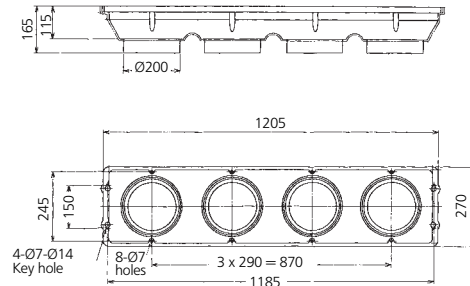

KDBH44BA60 - Sealing member of air discharge outlet

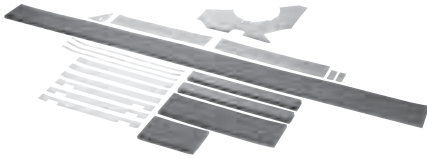

Name	Sealing material	Tape for fixing the sealing material	Insulation for side plate			Moisture absorber for bell-mouth	Moisture absorber for swing flap
Quantity	2 pieces	2 pieces	1 piece	1 piece	1 piece	1 piece	3 pieces
Shape	①	②	③ -1 100mm x 179mm	③ -2 100mm x 370mm	③ -3 100mm x 1538mm	④	⑤ 25mm x 361mm
Name	Moisture absorber for swing flap	Moisture absorber for panel edge	Moisture absorber for attached point	Moisture absorber for fresh air intake			
Quantity	3 pieces	3 pieces	1 piece	2 pieces			
Shape	⑥	⑦ 8mm x 450mm	⑧	⑨ 50mm x 20mm			

KDBH49FA80 · KDBHJ49F140 - Sealing member of air discharge outlet

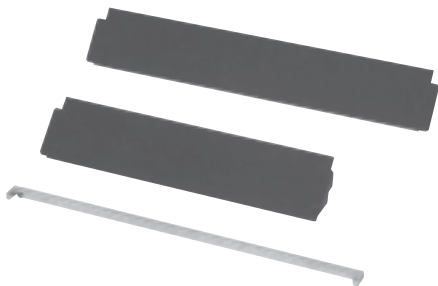

Dimensions

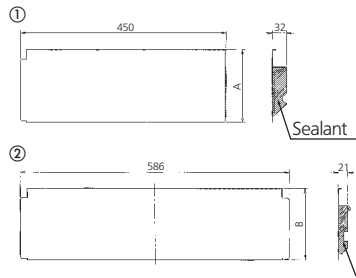

Unit: mm

Model	A	B
KDBH49FA80	100	100
KDBHJ49F140	155	155

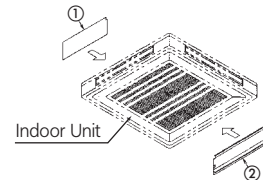

Unit: mm

Item	Model	KDBH49FA80	KDBHJ49F140
Material		Galvanized sheet Iron (with flocking)	
Accessories		Connecting plate: 1 Mounting clasp: 1 Mounting screw: 1 Installation Manual	

KDBHJ55K160 - Sealing member air discharge outlet



Component

Name	Sealed material A		Sealed material B		Sealed material C		Sealed material D	
Number	1		1		1		1	
Shape								
Name	Insulation for top plate		Insulation for side plate			Moisture absorber for bell-mouth		Moisture absorber for horizontal vane
Number	1	1	1	2	1	2	1	5 types
Shape			 240x615	 240x540	 240x490			 There are five colors to match the panel color.

KDBJ52F56W • 80W - Air discharge blind panel

- This is the parts which closes the lower discharge outlet when the unit is used as a front discharge style.

Specifications

		KDBJ52F56W	KDBJ52F80W
EXTERNAL COLOR		white	
EXTERNAL DIMENSIONS	H	18	
	W	1,326	
	D	119	
WEIGHT	kg	1.8	2.2
MATERIALS	steel plate		
CONTENTS	outlet decoration panel assembly, decoration panel suspension plate, name plate, caution plate set board		
APPLIED DECORATION PANEL	BYK71		
APPLICABLE MODEL	63 class		

External dimensions

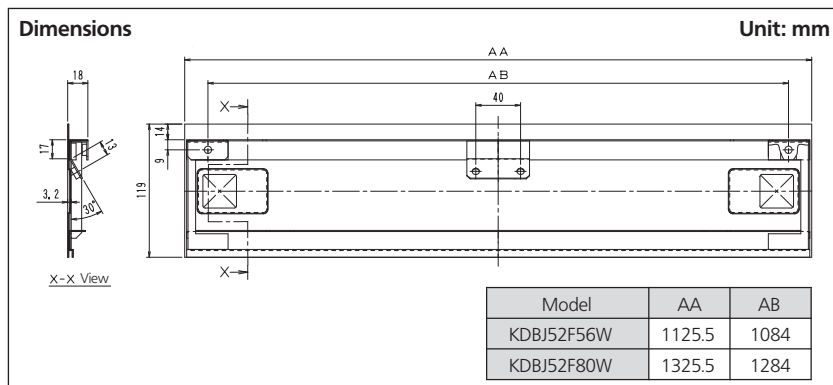

Example of usage

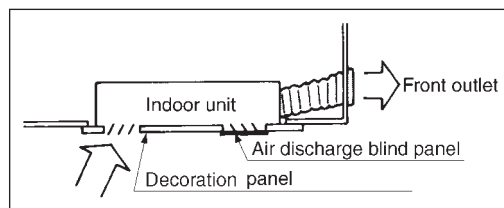

Additional required accessories

- Discharge grille
- Flexible duct with shutter
- This optional kit is to blind the bottom discharge outlet, when the unit is used with front air discharge.

KDBP55H160W - Panel spacer

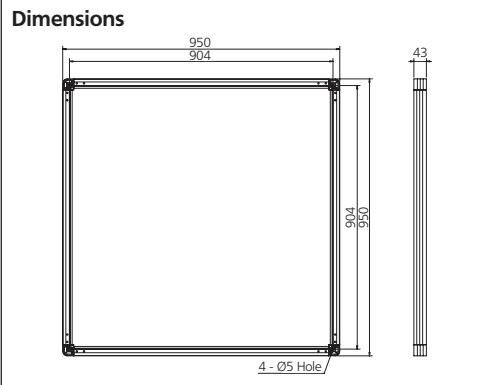
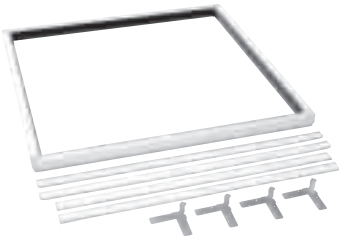

Item	Model	KDBP55H160W
Applicable decoration panels		BYC125K
Color		White
Materials		Outside frame: Resin Insulation: foam polyethylene
Component		Panel spacer, Insulation, Sealant, Mounting screws, Installation manual
Mass (kg)		1.2

Caution

- When the panel spacer is installed, it is not possible to have 2-way air outlet.
- Refer to the installation manual for both indoor unit and the panel spacer for its installation.

KDBQ44B60 - Panel spacer

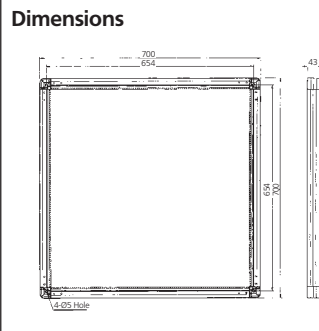
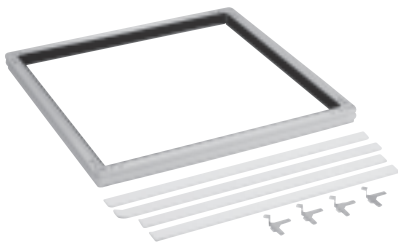

Installation

Unit: mm

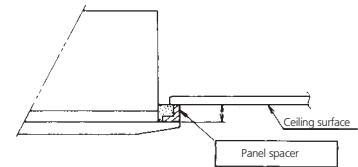

- Using the panel spacer in areas of the ceiling with limited space makes it possible to install the air conditioner.
- Hides the gap between the decoration panel and the ceiling.

Item	Model	KDBQ44B60
Applicable decoration parel		BYFQ60B
Exterior		White
Material		Outside frame: Aluminum extrusion and resin Insulation: Foam polyethylene
Component Parts		Panel spacer, Insulation, Sealant, Mounting screws, Installation manual
Weight (kg)		1.5

KDBTJ49F80 · 140 - Air discharge decoration panel



Dimensions

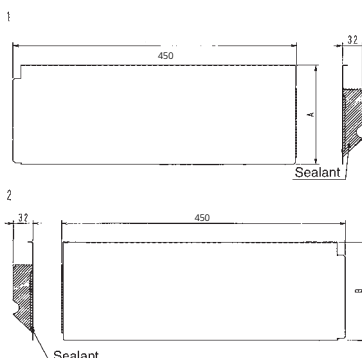

Unit: mm

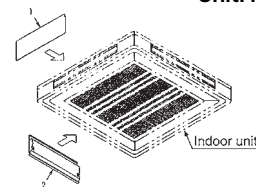

Part number	A	B
KDBTJ49F80	100	100
KDBTJ49F140	155	155

Item	Model	KDBTJ49F80	KDBTJ49F140
Material		Galvanized sheet iron (with flocking)	
Accessories		Installation Manual	

KDD55DA160K (with T-shape, without Fan) - Fresh air intake kit

Precautions for Use

1. Maximum length of the duct is 4 m.
2. An inspection hatch is required when inserting this kit. (Required for maintenance of the kit.)
3. Mount one or the other of the inspection hatch.
4. This should be assembled locally. This kit is designed for intake from both sides. If one side is blocked requiring intake from only one side, use KDDP55D160.
5. This kit cannot be used when the receiver for the infrared remote control is attached as it blocks intake from one side.

Dimensions

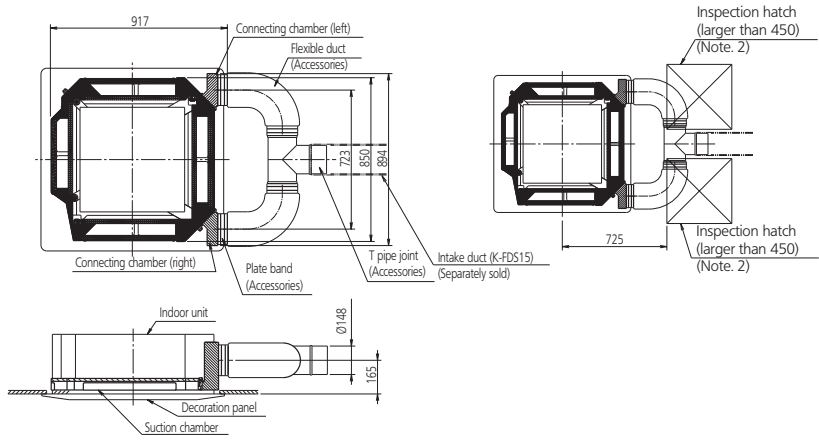

Unit: mm

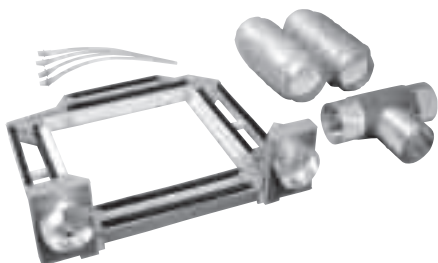

Item	Model	KDD55DA160K
Fresh air intake method		Fresh air intake by air conditioning fan.
Diameter of connection duct		Ø150
Accessories		T pipe joint: 1, Flexible duct: 2, Plate bands: 4, Mounting screws (M4×12): 4, Installation Manual
Weight (kg)		6.0

Model	Component
KDD55DA160K	Suction chamber
	KDDP55D160-1

KDDM24B100 - Silencer



Dimensions

Unit: mm

Model	A	B	C	D
KDDM24B100	380	480	250	260

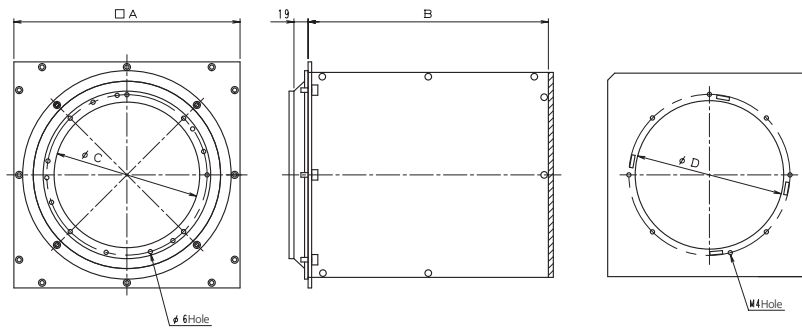

Item	Model	KDDM24B100
Silence effect (dB)		approx. 6
Component parts		Silencer, Fixing screws

KDDP55D160 (without T-shape, without Fan) - Fresh air intake kit

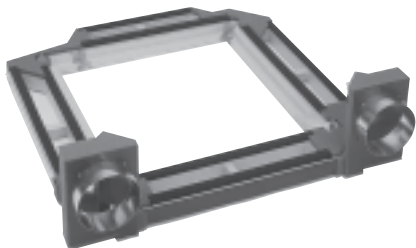

Dimensions

Unit: mm

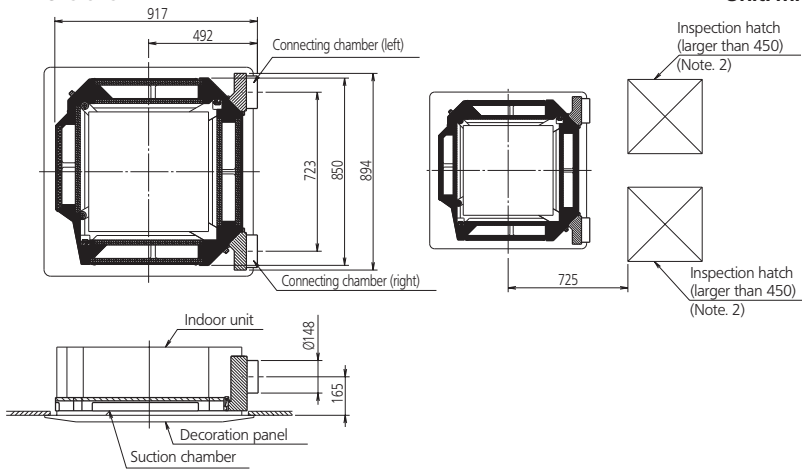

Precautions for Use





1. An inspection hatch is required when inserting this kit (Required for maintenance of the kit)
2. Mount one or the other of the in spection hatch.
3. This should be assembled locally.
4. If there is any obstacle to make air intake from both sides hard, air intake from one side will be enabled.
5. If the light receiver unit for the remote control is mounted to the main unit, air should be taken in from the right side.

Item	Model	KDDP55D160
Fresh air intake method		Fresh air intake by air conditioning fan.
Diameter of connection duct		Ø150
Accessories		T pipe joint: 1, Flexible duct: 2, Plate bands: 4, Mounting screws (M4×12): 4, Installation Manual
Weight (kg)		4.2

Model	Component	
	Suction chamber	Connecting chamber · Tpipe
KDDP55D160	KDDP55D160-1	KDDJ55B160-2

KDDQ44XA60 (Direct Installation Type)

Contents

Name	① Duct flange	② Screw	③ Insulation for duct flange	④ Insulation for opening of unit	⑤ Installation manual
Q'ty	1 piece	4 pieces	1 piece	1 piece	1 piece
Shape		 M4 x 12			

Necessary tools

Philips head screw driver, nipper, cutter etc.

KDGJ49F80 · 140 - Vertical flap kit

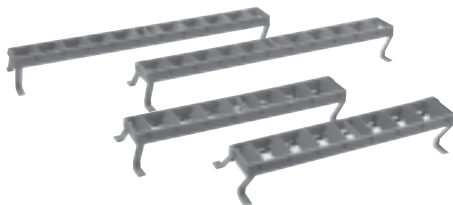

Dimensions

KDGJ49F80

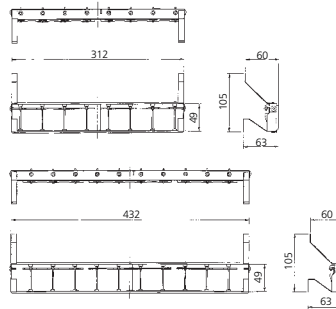

KDGJ49F140

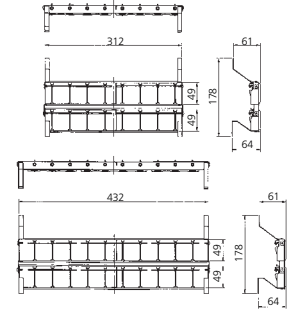

Unit: mm

Item	Model	KDGJ49F80	KDGJ49F140
Material		Blade fixing plate: Galvanized sheet Iron Blade: polypropylene	
Number in box		4(2×2 each)	
Accessories		Installation manual	

KDJ3705L280 - Filter chamber



Dimensions

Unit: mm

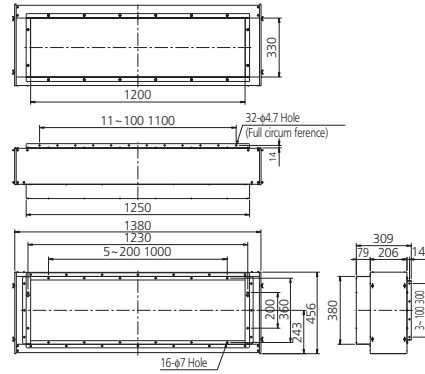

Item		Model	KDJ3705L280
Inserted filter	Long-life filter		KAFJ371L280
Weight (kg)			14
Specifications			Hot galvanization
Accessories			Mounting Screws, Installation manual

KDU30L125,250 - Drain pump kit



Specifications

		KDU30L125	KDU30L250
POWER SUPPLY		single phase 220-240v/220v 50/60hz	
POWER CONSUMPTION	W	19/17 (50/60hz)	
DRAIN-UP LIFT	mm	standard drain outlet of the unit +294	standard drain outlet of the unit +197 ~ +447
DRAIN OUTLET		VP25 (internal diameter ø25, external diameter ø32)	
SAFETY DEVICE		float switch	
WEIGHT	kg	9	10
APPLIED MODELS		40-50-63-80-100-125 class	200-250 class

Precaution at use

- When this kit will be used together with the natural evaporation pan type humidifier, the piping of unit's drain and humidifier's drain can be used in common.
- Be sure to do test run (cooling) to make sure the drain flows out.
- Prohibit providing a drain trap when the drain pump kit will be mounted.

Installation

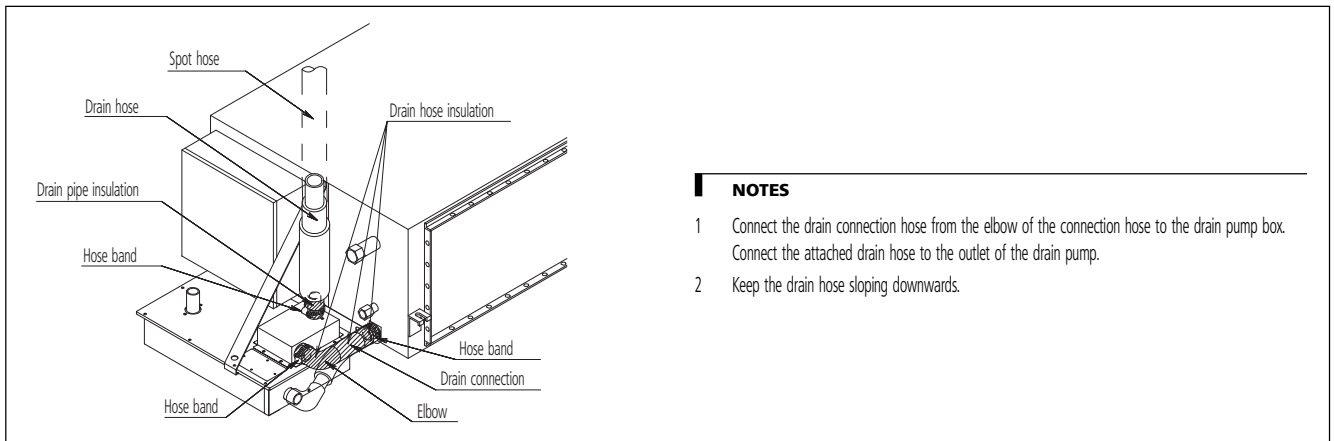

NOTES

- 1 Connect the drain connection hose from the elbow of the connection hose to the drain pump box. Connect the attached drain hose to the outlet of the drain pump.
- 2 Keep the drain hose sloping downwards.

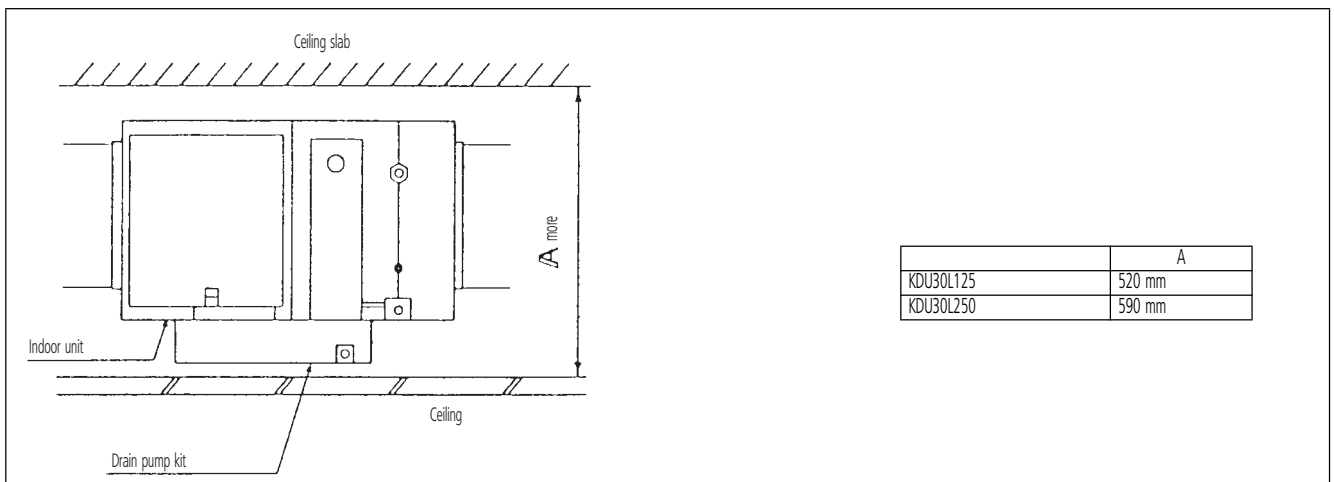

	A
KDU30L125	520 mm
KDU30L250	590 mm

KDU30L125,250 - Drain pump kit

KDU30L125

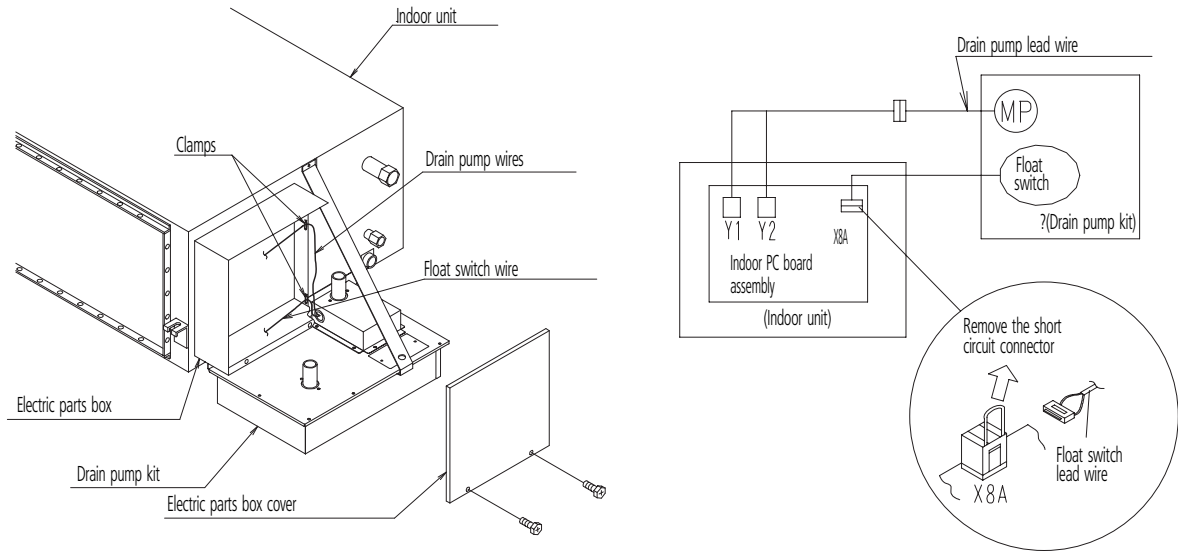

KDU30L250

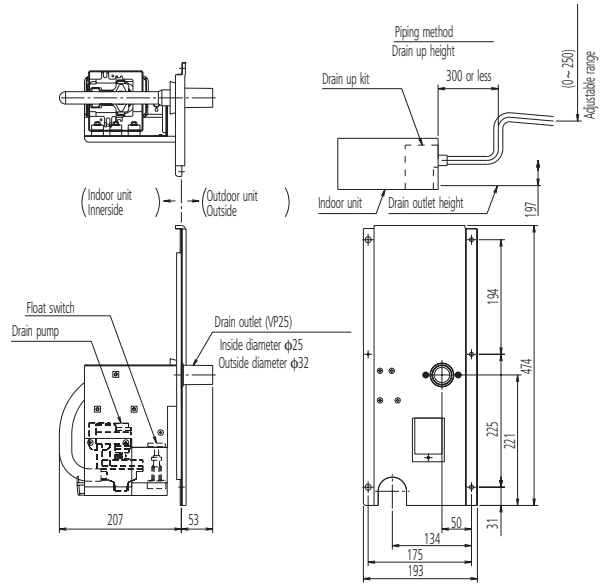
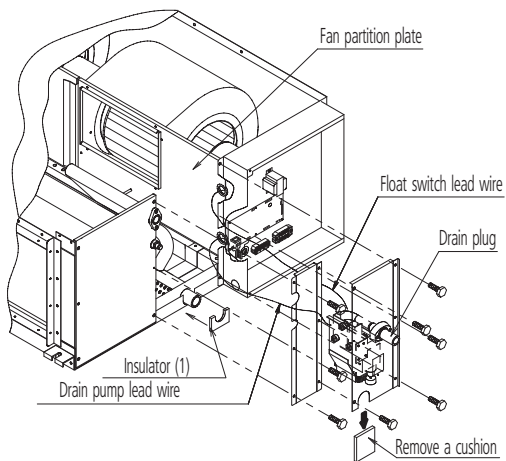
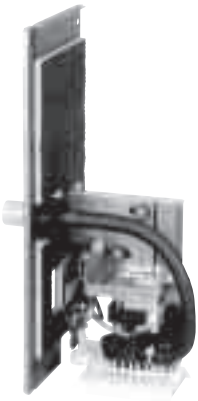

KDU50M60 · 125 - Drain pump kit



Dimensions

Unit: mm

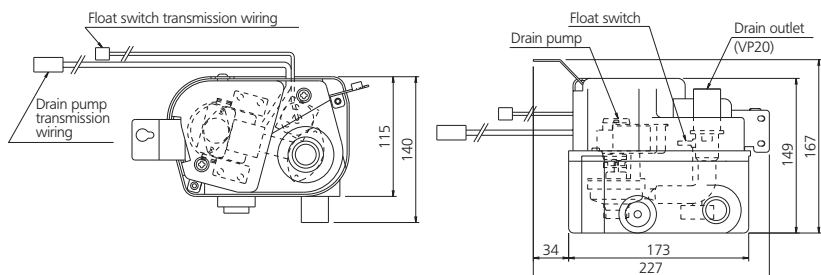

Drain Up Kit – Allows draining to higher places using a drain pump

- In cases where it is impossible to mount drains indoors due to existing buildings or building construction.
- When drain pitch cannot be obtained inside the ceiling.
- Includes a leak prevention safety device.

Caution

1. Perform heat insulation in drain pipes which run indoors.
2. Do not switch off the power immediately after turning off the cooling. →The drain function will run for approximately 5 minutes.

Item		Model	KDU50M60	KDU50M125
Drain up height (mm)	A		600	
Pump	Power supply		220-240/220V 50/60Hz	
	Electricity consumption		20/17W	
	Insulation class		E	
Drain outlet			VP20 (Outside dia. Ø25, Inside dia. Ø20)	
Safety device			Float switch	
Installation site			Attached inside the indoor unit	
Weight (kg)			1.8	2.2
Component parts			Drain up kit, Drain hose, Band, Insulation, Attached piping for gas side, Attached piping for liquid side, Screws, Operation manual	

Installation

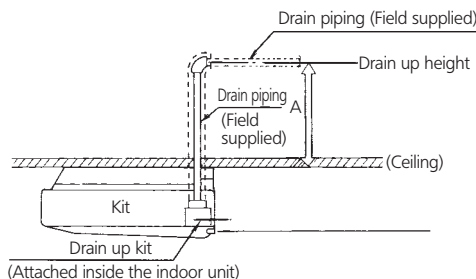

- Note:
- use the upper connection hole for the refrigerant piping at the right rear of the ceiling as the position to bring out the drain up piping.
 - Only the upper direction will be left for the refrigerant piping.

KEK26-1A

Component parts

	Body	Installation screw	4
		Clamp	2
		Relay harness	1
		Installation manual	2

- Store this optional accessory in the control box.
- When supplying a control box at site, prepare a control box whose dimensions are equal to or larger than the figures shown below.
Width × Height × Depth = 136 × 117 × 44 mm

KFDJ52F56 · 80 - Flexible duct with shutter

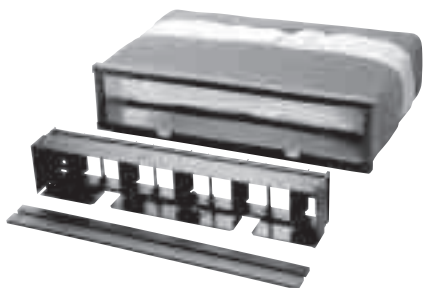

- Internal shutter
→ Using the shutter allows adjustment of fan strength for front and bottom directions.
- Location of attachment can be varied within 20 mm up or down. Connection to indoor unit also easy to do.

Dimensions

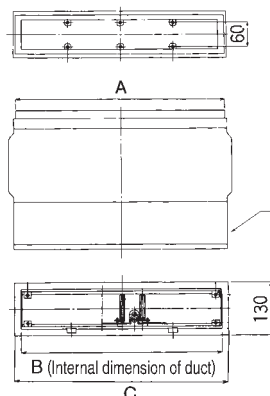

Unit: mm

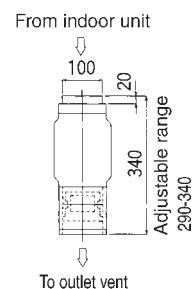

Model	A	B	C
KFDJ52F56	520	498	530
KFDJ52F80	720	698	730

Installation

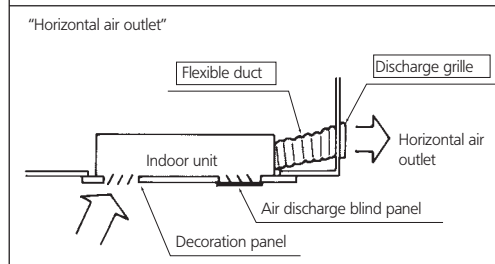
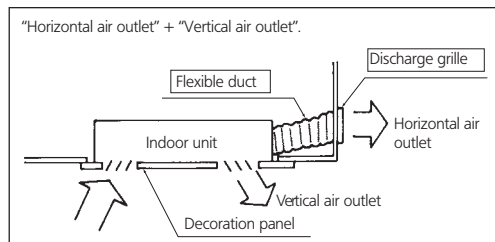

Item	Model	KFDJ52F56	KFDJ52F80
Thermal insulation		Material: glass wool (t=25 mm, specific gravity=24 kg/m ³)	
Mass (kg)		4.5	5.0
Component parts		Flexible duct, Shutter, Setting plate for duct, Sealing pad, Shutter adjuster, Screws, Thermal insulation, Installation manual	

KHFP49MA140 - L connection piping kit

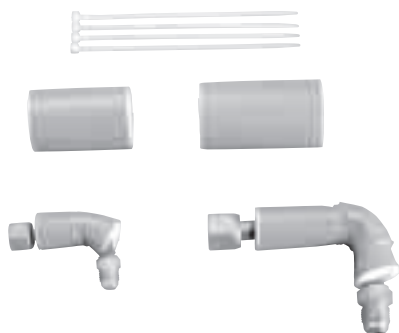

Dimensions

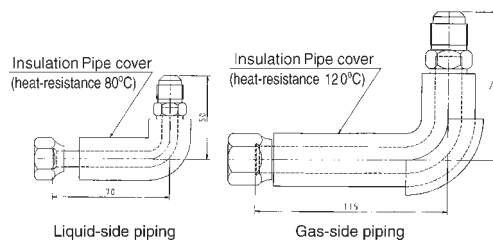

Unit:mm

Model	Connection piping diameter		
	Liquid side	Gas side	A
Accessories	Insulation, Binding band		

KHFP5M35 · 63 · KHFP5MA160 - L-type piping kit (for upward direction)

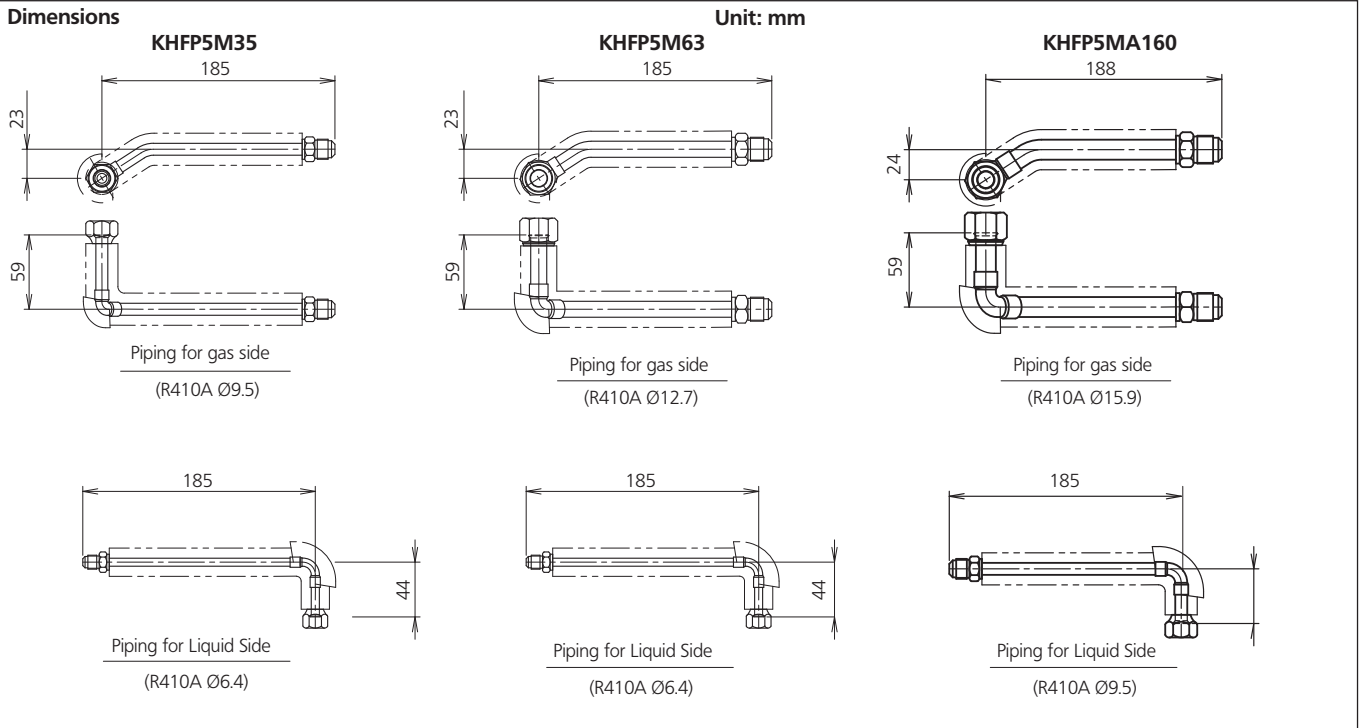

Item	Model	KHFP5M35	KHFP5M63	KHFP5MA160
Accessories		Insulation for Fitting, Clamp Material		

Reduces local piping work.

Auxiliary Piping

- Use when connecting local piping directly to the outdoor unit is difficult.
- Front-side or rear use may be selected according to the direction the piping comes out.



Precautions concerning attachment

- When attaching the auxiliary piping, make sure the piping does not come into contact with the compressor or casing, as this may cause vibration or unusual sounds.

Refnet pipe systems

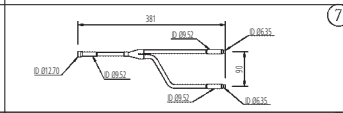
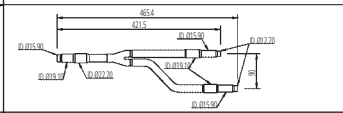
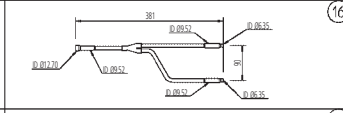
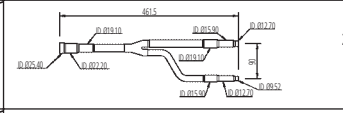
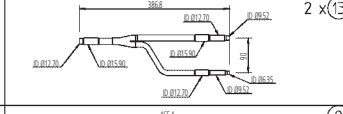
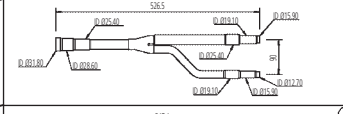
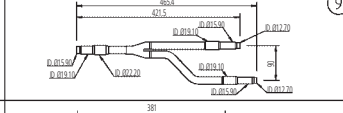
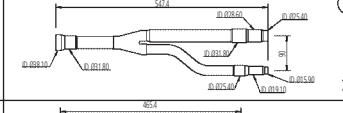
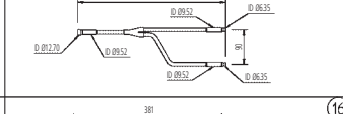
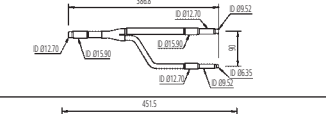
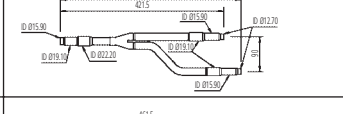
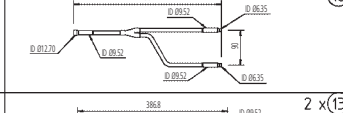
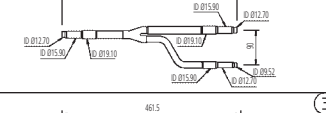
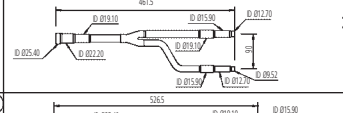
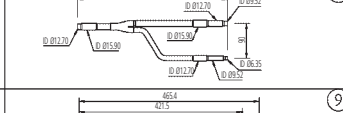
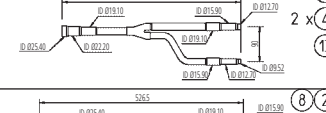
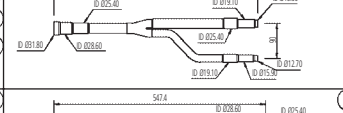
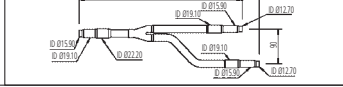
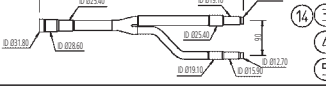
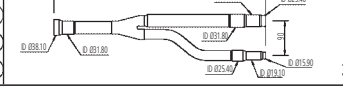
2

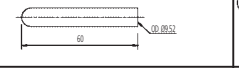
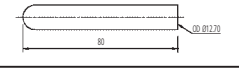
	Liquid side junction	Discharge gas side junction	Suction gas side junction
KHRQ22M207A			
KHRQ22M2979			
KHRQ22M64T			
KHRQ22M75T			
KHRQ23M20T			
KHRQ23M29T			
KHRQ23M64T			
KHRQ23M75T			

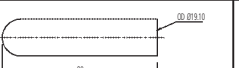
Closed pipes					
A		B		C	
D		E			







	Liquid side header	Discharge gas side header	Suction gas side header
KHRQ22M29H			
KHRQ22M64H			
KHRQ22M75H			
KHRQ23M29H			
KHRQ23M64H			
KHRQ23M75H			

KHRQ250H7			
KHRP127HB			
KHRQ127H			

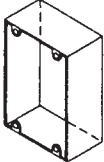
Reducers - Expanders	①	②	③
	④	⑤	⑥
	⑦	⑧	⑨
	⑩	⑪	⑫
	⑬	⑭	⑮
	⑯	⑰	⑱
	⑲	⑳	㉑

KJB111A - Fixing box (for cool/heat selector)
KJB212A/311A/411A - Electrical box with earth terminal

Component parts

Name	Switch box	Cover	Wood screw A (5.1×25)	Clamp screw B (M4×16)	Earth screw (M4×12)	C-CUP Washer	Label for Earth
Qty	KJB111A	1	2	2	-	-	-
	KJB212A	1	4	4	3	2	1
	KJB311A	1	4	4	3	3	1
	KJB411A	1	4	4	-	-	-
Shape							



Dimension

KJB111A

Unit: mm

KJB212A · 311A · 411A

Unit: mm

Model	Size (mm)			
	A	B	C	D
KJB212A	136	138	44	70
KJB311A	182	184	44	110
KJB411A	228	230	54	155

K-KDU572CVE - Drain pump kit



Dimensions

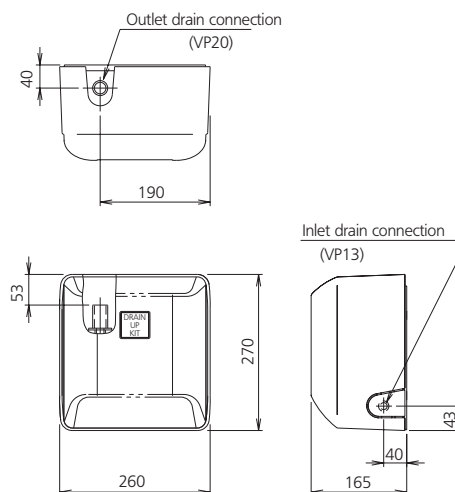

Unit : mm

Specification

K-KDU572CVE		
Drain pump height (mm)	(Note 1) 1,000	
Drain up mechanism	Power supply	Single phase 220-240V/220V, 50/60Hz
	Power consumption	15.6/14.1 (W)
	Operating current	0.26/0.26 (A)
	Insulation	Class E
Drain inlet connection pipe diameter	VP20 (Note 2)	
Drain exit connection pipe diameter	VP20	
Safety device	Float switch	
Operating noise (dB)	25	
Machine weight (Mass)(kg)	3.0	

Note : 1. Height from bottom of drain pump kit up to the drain pipe.
2. Connect to the VP13 using the soft reducing socket.

Features

1. Silent operation with no sign of pump operation
2. Design matching with wall mounted type air conditioner
3. Can be interlocked with air conditioner.

Usage

- Home, office, and store
- Optimum for redesign

Caution: • Drain pump kit is only for the air conditioner. Please use it for the drain treatment of the air conditioner.
• Be sure to lay the piping inclined down after drain-up, which is different from drain pump.
• Please do not use it in the place where soot such as kitchens is shrouded and the place where an organic solvent drifts.

Wiring Diagram

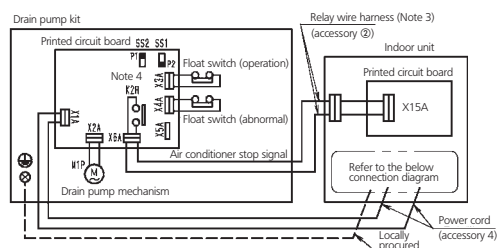

Application model	FAYP71LV1	FXAQ20-25-32MVE FXAQ40-50-63MVE(C)	FAQ71BLV1B
Connection diagram			

The earth wire (copper) should be at least 2.0mm² or Ø 1.6mm.
When the relay wire harness is connected, remove the X15A short-circuit connector.

- Note :
1. Don't forget to turn on the power. If it is not turned on, the air conditioner will perform an error stop and operation will not be possible.
 2. Make sure that slide switch SS1 on the drain pump kit printed circuit board assembly is set to P2 and slide switch SS2 is set to P1.
 3. The relay wire harness cannot be extended.
 4. Turning on the power will close the K2R connector, making it a non-volt B connector.

KKF917AA4 - Anti-theft protection for remote control



Dimensions

Unit: mm

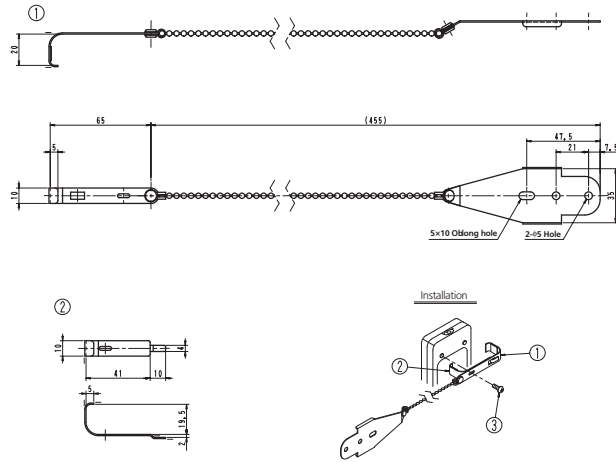

Item	Model	KKF917AA4
Components		Main body Ball chain (35cm) Metal fitting Mounting screw Driver Operation manual

KKF936A4 - Anti-theft protection for remote control

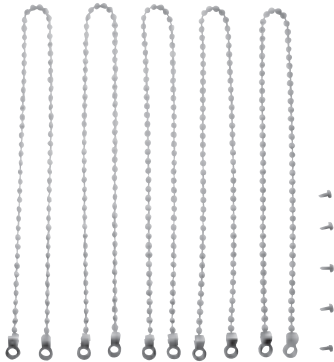

Dimensions

Unit: mm

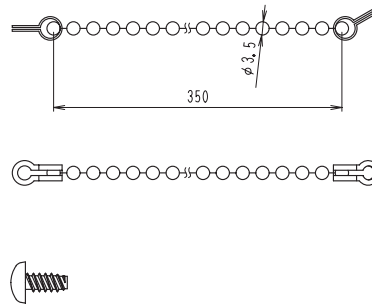

Item	Model	KKF936A4
Components		Ball chain × 5 Screws (M3 × 5) × 5 Operation manual

KKF936A4 Mounting Procedure

- (1) Tighten the Chain with the screw to the screw hole on the rear side upper left of the remote controller.
- (2) Before tightening the screws, make sure the signal from remote controller is transmitted to the unit. Mount the remote controller holder and chain with screw holder (Attached with the indoor unit).

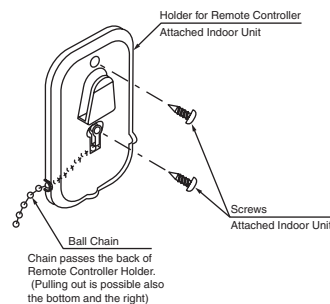
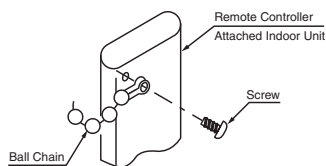

KKP937A4 - Drain plug



Dimensions

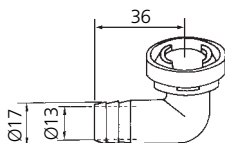

Components

- Drain Plug (5pcs.)
- Connectable Drain Hose: Ø16 (I.D.)

KKPJ5F180 - Central drain pan kit

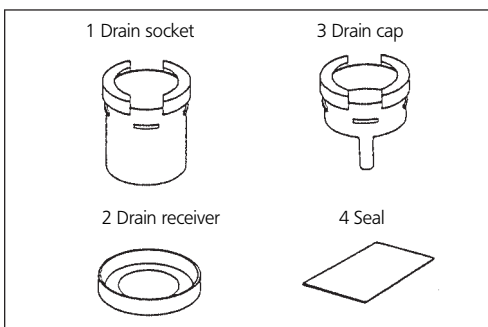

Item	Model	KKPJ5F180
Connecting drain hose		Ø25 (inside diameter)
Component parts		Drain socket (1) · drain cap (2) Drain receiver (3) · seal (1 sheet) Installation Manual

KPBJ52F56,80 - Panel spacer

KPBJ52F56

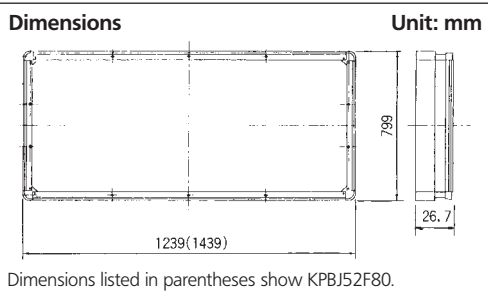
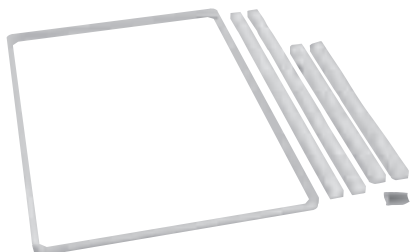

Item	Model	KPBJ52F56	KPBJ52F80
Color		White	
Material		Aluminum extrusion (resin used on corner part only)	
Component		Panel spacer, Insulation, Screws, Installation manual	
Mass (kg)		1.6	1.8

Installation

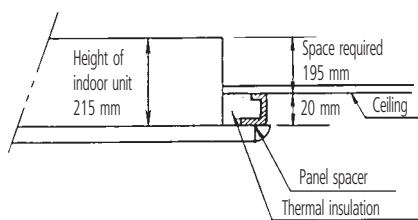
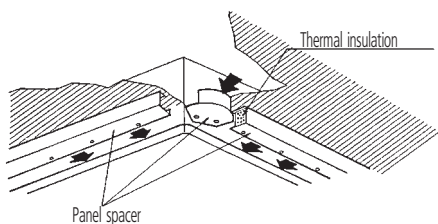

Precaution at use

Be sure to stick insulators on the panel spacer after the panel spacer is assembled
Secure 20 cm height in the space above ceiling.

KPMH974A402 · KPMH942A42 · KPMH950A4L · KPMJ942A4

Options for humidifying hose

Item	No.
Humidifying Hose Extension (Extension Hose 2m, Extension Joint 1 pc. and Cramp Material 2 pcs.)	KPMH974A402
Humidifying Hose Extension Joint (10pcs.)	KPMJ942A4
Humidifying Hose L Cuff (10pcs.)	KPMH950A4L
Humidifying Hose (10m)	KPMH942A42



KPW937A4 - Air direction adjustment grille



Dimensions

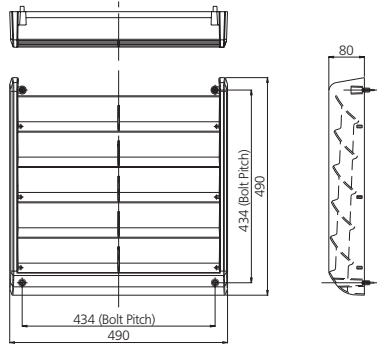

Item	Model	KPW937A4
Material		Resin
Air Direction		Upper-Lower-Left-Right
Color		Ivory white
Accessories		Screws, Installation Manual
Mass (kg)		1.1

KPW945A4 - Air direction adjustment grille



Dimensions

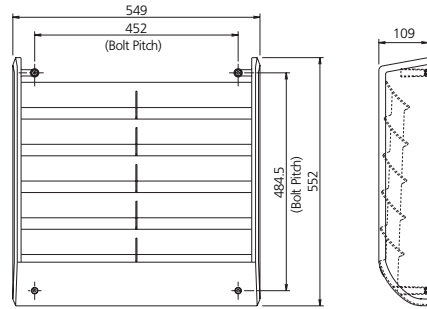

Item	Model	KPW945A4
Material		Resin
Air Direction		Upper-Lower
Color		Ivory white
Accessories		Screws, Installation Manual
Mass (kg)		1.5

KRC19-26 - Cool/heat selector

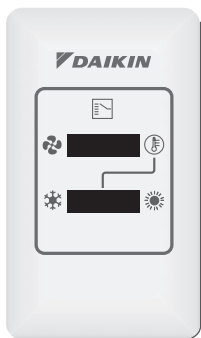

Dimensions

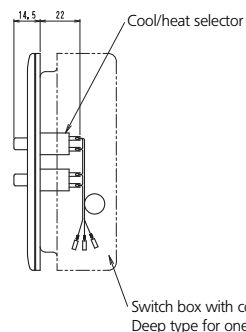
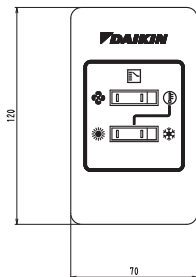

Unit: mm

KRC72

Model	KRC72
Item	
Max. Controllable Units	Up to 5 rooms
Additional PCB Boards	When using this kit, please prepare the P-board (print circuit board) set of remote control (KRC72) of the same number as that of the air conditioners (indoor unit) to be controlled.
Max. length of connection wires	Max. 50m / Unit
Parts of Components	Upper case of switch box (1pc.) Lower case of switch box (1pc.) Lower case (1pc.) Operation panel (1pc.) Face pate of room name (1pc.) M4 screw (6pcs.) Screw for switch box (4pcs.) Operation manual (1pc.)

Dimensions

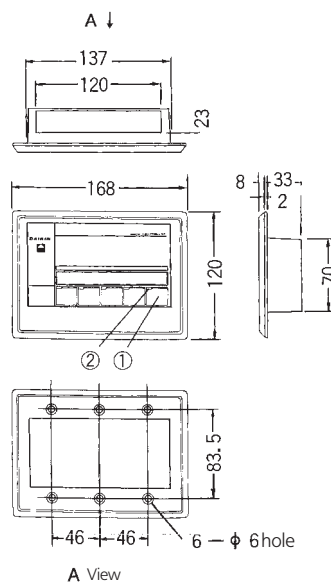

Unit: mm

KRCS01-1 - Remote sensor



Dimensions

Unit: mm

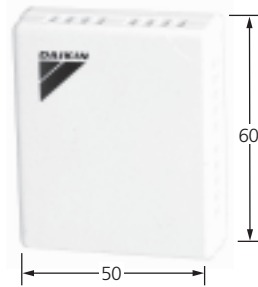

- Recommended for ceiling suspension and ceiling-embedded types which often result in a difference between set temperature and actual temperature.
- The sensor for detecting the temperature can be placed away from the indoor air conditioner. (Branch wiring is included in the kit.)

Item	Model	KRCS01-1
Length of branch wiring (m)		12
Appearance		Light ivory (with the Daikin logo)
Box material		ABS resin
Weight (kg)		0.3
Component parts		Remote sensor, extension cord, screws, terminals, tie-wraps, two-sided tape Installation Manual

Precautions for use

- Select a location for the sensor where it can detect the average temperature. Avoid the following locations.
 1. Locations in direct sunlight.
 2. Locations where the outlet air from the air conditioner is directed.
 3. Locations close to other heat sources.
 4. Locations near doors which might be affected by air coming in.

KRP1B2 - Adapter for wiring

Accessories Check if the following accessories are included in the kit,

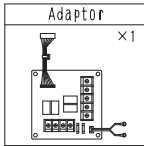

PC board support	×4
Clamp	×3
Installation manual	×1

- Notes**
- Kits vary according to applicable models.
 - A special adaptor fixing plate and box are required for the following models,
 FXCQ, FXYC, FXYCP KRP1B96
 FXYFP KRP1C98

1 NAMES OF PARTS

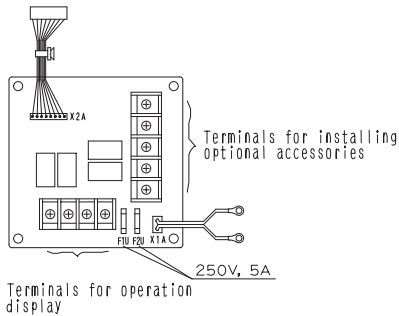

2 ELECTRIC WIRING

- Refer to the WIRING DIAGRAM attached to the indoor unit before attempting to wire. (Make sure wires to units do not pass over the PC board when wiring.)
- Wire the adaptor to the indoor unit as shown below.

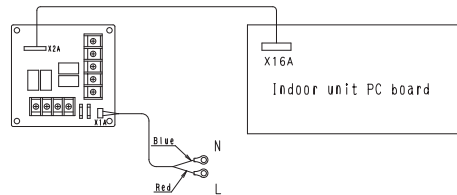

- ① Fetching the operation display signal
- Attaching an hour meter
 - Output is generated at the contact while the compressor is running.
 - Example: x1, x2
 - HM : Hour meter (Part to be procured in the field)
 - AC 220~240V
 - Fan ON display
 - Output is generated at the contact while the fan is running.
 - Example: x3, x4
 - RL : Operation lamp (Part to be procured in the field)
 - AC 220~240V
- ② If optional accessories are installed (auxiliary electric heater, humidifier)
- Wire correctly in accordance with the attached installation manual.
 - Refer to the wiring diagram applied to the indoor unit when running electric wiring.

KRP1B3 - Wiring adapter

Interlock adapter of VRV

Contents of kit

Prior to installation check whether you have the complete kit of parts as shown below including the installation manual.

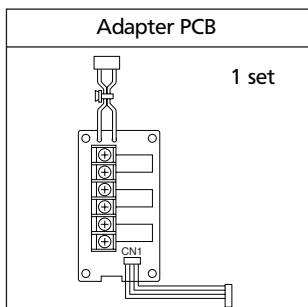

Plastic strap	3 pieces
Installation manual	1 piece

Electrical wiring

- Refer to the wiring diagram of the indoor unit for its wiring connection. (Make sure all the wiring to the unit should not go over the PC board.)
- Connect the wiring to the indoor unit as shown below.

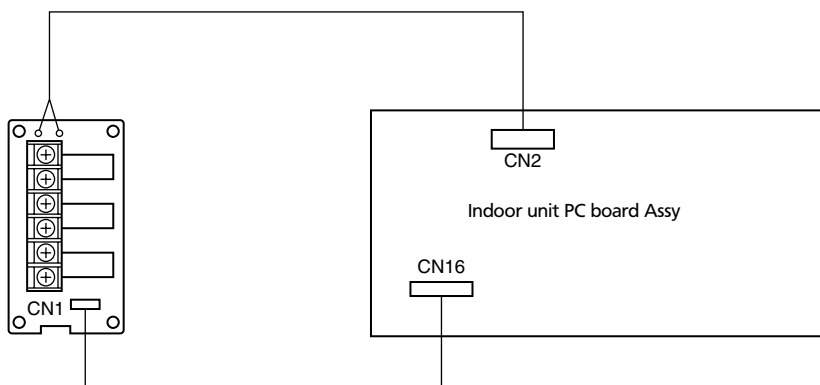

Installation

- Never bundle high and low voltage wiring together.
- Be sure to bundle the excess wiring with the attached plastic strap so as to keep the loose wiring off the indoor unit PC board.

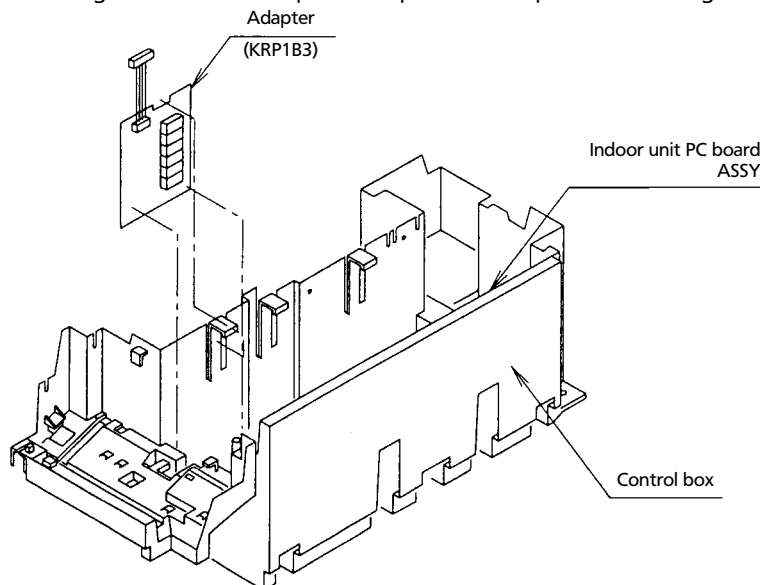

KRP1B54 - 57 - Adapter PCB for wiring
KRP1B59 - Wiring adapter

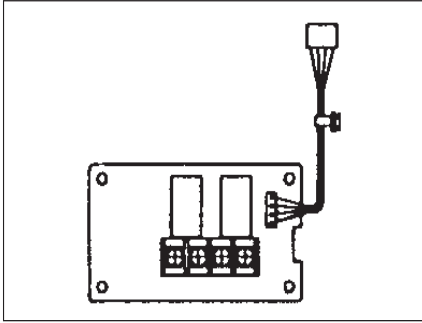
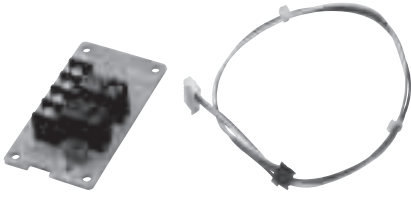

Item \ Model	KRP1B54	KRP1B57	KRP1B59
Dimensions (mm)	85×49		
Length of lead wire (mm)	250	1,500	500
Component parts	Wiring adaptor PCB, PCB support, clamp, Installation manual		

KRP1B61 - Wiring adapter

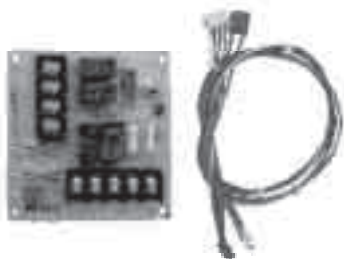

Item	Model	KRP1B61
Dimensions (mm)		100×100
Length of lead wire (mm)		400
Accessories		PC board support, Clamp, Installation manual

Outline/Features

This adapter is required one for each indoor unit when you install the auxiliary electric heater, the humidifier and the fresh-air intake kit. This adapter also can output the signal of the compressor operation/fan operation.

Applied Model

- All the indoor unit of VRV system and Sky Air series.
(The type of adapter differs depending on the model of indoor unit. For details, refer to the last item of this section.)

System Configuration

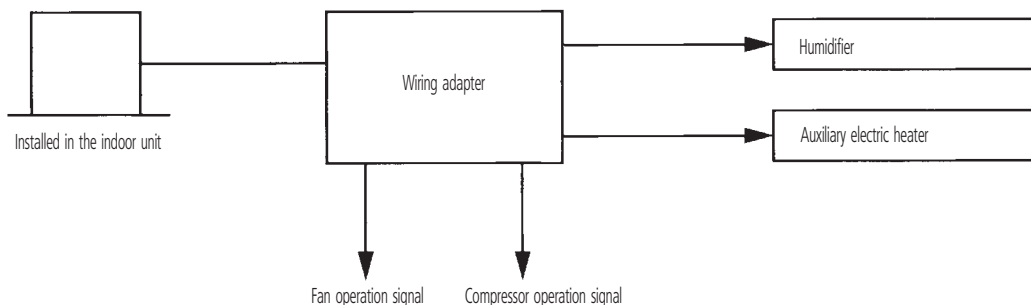

Description of Functions

1. Compressor operation signal

Outputs the compressor operation/stop signal by detecting the thermostat ON/OFF signal from each indoor unit. (No voltage normally open contact, "ON" when thermostat is ON.)

2. Fan operation signal

Outputs the fan operation/stop signal from each indoor unit. (No voltage normally open contact, "ON" when fan operates.)

3. Attachment of auxiliary heater and humidifier

Requires one adapter for each indoor unit when these options are to be installed.

Operation display signal

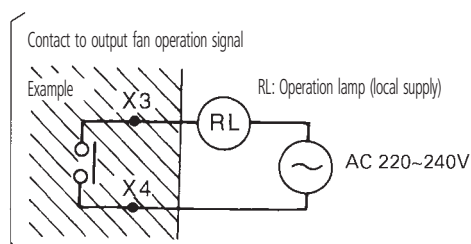
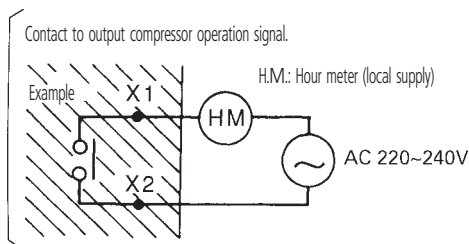

KRP1B96 - Wiring adapter



Dimensions

Unit: mm

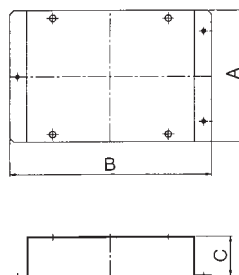

Model	A	B	C
KRP1B96	102	262.5	5

Item	Model	KRP1B96
Applicable adaptor		KRP4A1
Installation		Interior of unit
Material		Hot-dip zinc-coated carbon steel sheet
Component parts		Fixing plate, Mounting screw

KRP1B97 - Installation box for adapter PCB



Dimensions

Unit: mm

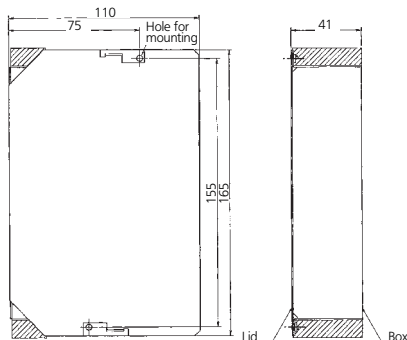

Item	Model	KRP1B97
Material		Hot-dip zinc-coated carbon steel sheet
Accessories		Truss head tapping screws, Cord stickers, Installation Manual

KRP1BA101 - Installation box for adapter PCB

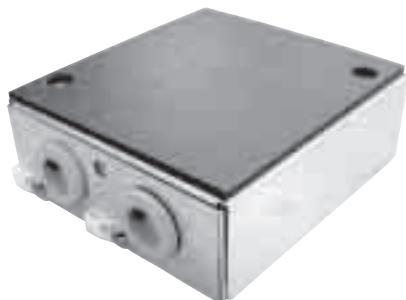

Dimensions

Unit: mm

Accessories Check the following accessories are include in this kit.

Name	Installation box	Lid of installation box	Clamp	Screws	Cord sticker	Installation manual	Screws
Quantity		x 1	x 3	x 3	x 3	x 1	x 2
Shape							

Applicable Adapter
(In case of FFQ, FXZQ type)

Adapter	Kit name
Adapter for wiring	KRP1B57
Wiring adapter for electrical appendices (1)	KRP2A52, KRP2A62
Wiring adapter for electrical appendices (2)	KRP4A53
External control adapter for outdoor units	DTA104A52

Applicable Adapter
(In case of FXD, FXDQ type)

Adapter	Kit name
Wiring adapter for electrical appendices (2)	KRP4A54
External control adapter for outdoor units	DTA104A53

2

KRP1C93 - Installation box for adapter PCB



Item		Model	KRP1C93
Installation			Interior of unit
Material			Hot-dip zinc-coated carbon steel sheet
Dimensions (mm)	Wigth		109
	Length		124
	Depth		38
Component parts			Installation box, Box cover, Clamp, Screws, Installation Manual

KRP1D98 - Installation box for adapter PCB

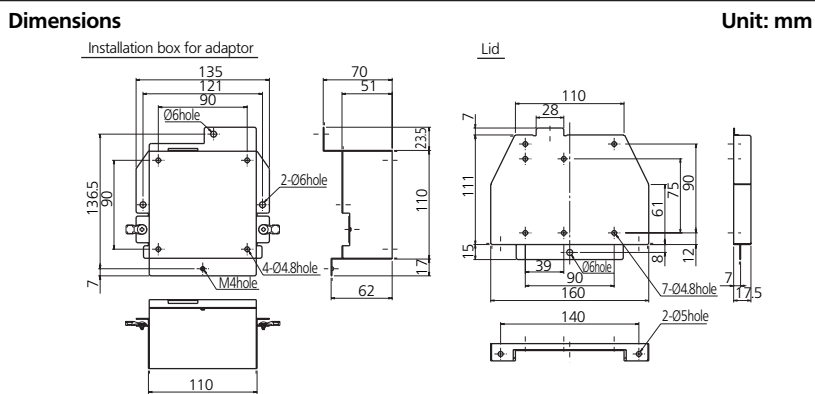
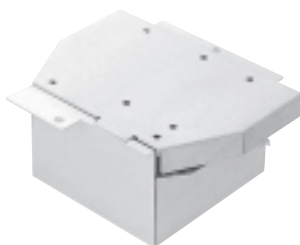

Item		Model	KRP1D98
Materials			Hot-dip zinc-coated carbon steel sheet
Accessories			Electric wire clamp, Mounting Screw, Installation manual

KRP2A51 · 53 · 61 · 62 - Wiring adapter for electrical appendices

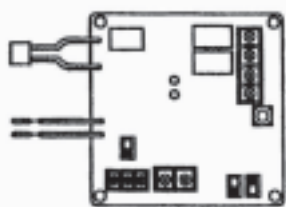

Item		Model			
		KRP2A51	KRP2A53	KRP2A61	KRP2A62
Dimensions (mm)		100×100			
Length of lead wire (mm)		500	2,000	500	1,300
Component parts		Wiring adaptor PCB, PCB support, clamp, Installation manual			

KRP413A1S - Remote control PCB

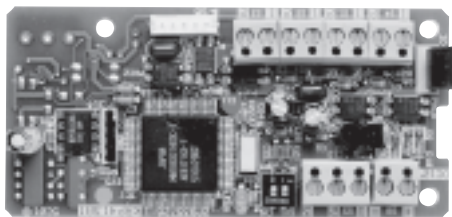

Item	Model	KRP413A1S
HA Case		Attached
Connectable Control		KRC72 (5 room centralized Control)
Control Signal		Instant Contact / Normal Contact Changover
Remote Control		Operation / Stop
Remote Display		① LED Display is possible ② Lamp Display [Note1]
Max. Wiring Length (m)		100
Dimensions (mm)		W141×H30×D76
Accessories		HA Case Relay Harhess (about 0.8m) Binding band Velcro Screws Installation Manual
Application		Standard Remote Control

Note 1. Possible: Relay circuit (Field Supply) is required.

KRP4A51 · 52 · 53 · 54 - Wiring adapter for electrical appendices

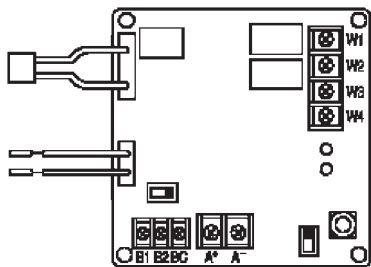

Item		Model	KRP4A51	KRP4A52	KRP4A53	KRP4A54
Dimensions (mm)			100×100			
Length of lead wire (mm)	Power Line		500	800	1150	1900
	Transmission Line		500	600	1150	1700
Accessories			PC Board, Board support, clamp, Installation manual			

KRP4A93 - Installation box for adapter PCB



Item	Model	KRP4A93
Applicable adapter		KRP4A1-2-3-4
Installation		External
Material		Hot-dip zinc-coated steel sheet for painting
Dimensions	Width	160
	Height	180
	Thickness	50

2

KRP50-2 - Wiring adapter for remote contact / Humidifier

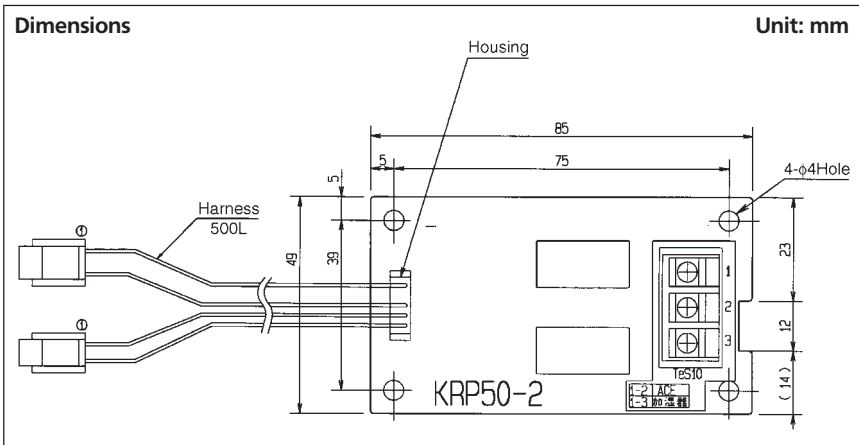

Item	Model	KRP50-2
Dimensions (mm)		85×49
Length of lead wire (mm)		500
Component parts		PC Board, Board support, Clamp, Installation manual

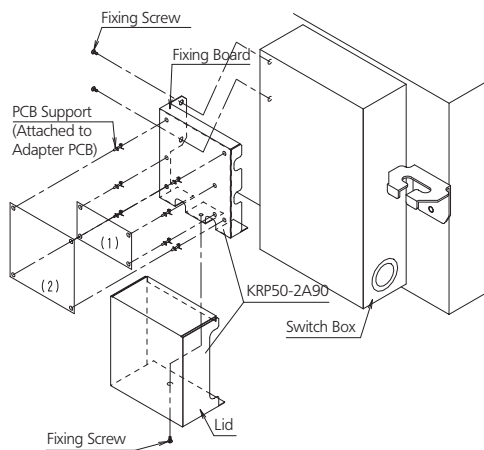

Applicable adapter

	Adapter name	Kit name
(1)	Adapter PCB for Humidifier	KRP50-2
(2)	Adapter PCB for Remote control	KRP2A61

KRP50-2A90 - Installation box for adapter PCB

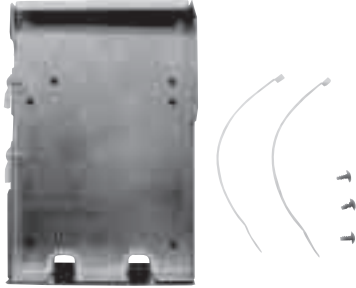

Dimensions

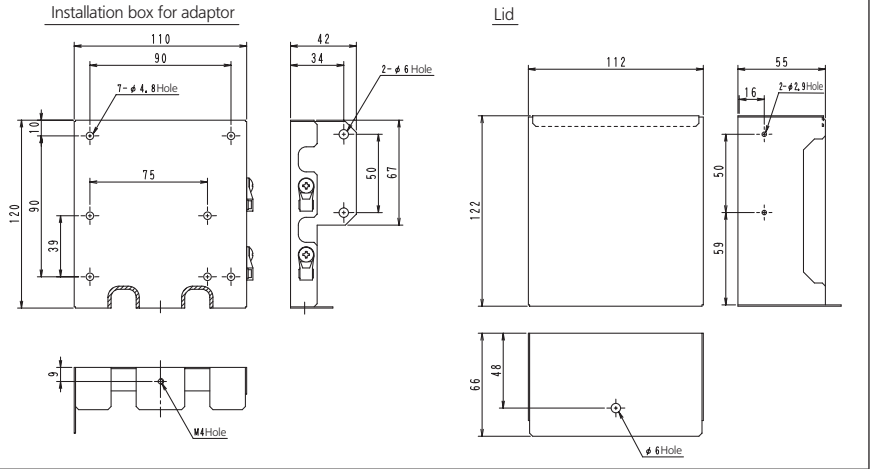

Item	Model	KRP50-2A90
Material		Hot-dip Zinc-coated carbon steel sheet
Accessories		Cable clamp, Fixing screw, Installation manual

KRP928A2S - Interface adapter for Split inverter

View

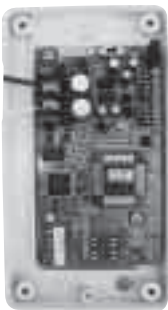

Outline

This interface adapter allows to link all split inverter units to the DIII net (F1/F2). Lower and upper group number are set by means of DIP switches as well as the choice between auto restart and no auto restart after power failure.

System Configuration

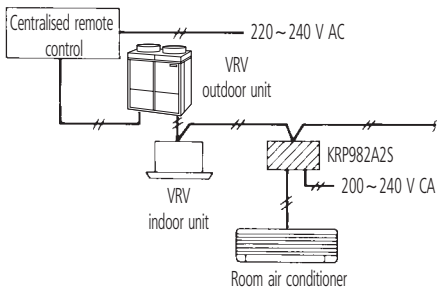

2

KSA-25K36 · 56 · 160 KSA-25KA80 - Air suction canvas



Dimensions

Unit: mm

Model	A	B	C	D
KSA-25K36	550	514	125	225
KSA-25K56	700	664	200	300
KSA-25KA80	1,000	964	350	450
KSA-25K160	1,400	1,364	550	650

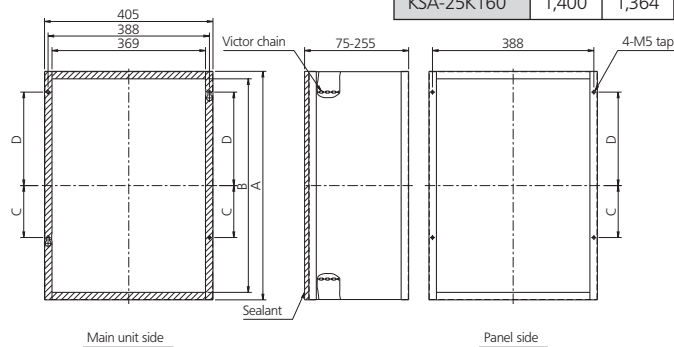

- Can be attached so that there is no gap in the ceiling using the included turn buckle.

Item	Model	KSA-25K36	KSA-25K56	KSA-25KA80	KSA-25K160
Canvas duct		Flame retardant			
Weight (kg)		1.8	2.2	2.8	3.6
Component parts		Air suction canvas, Turn buckle · Mounting screw, Adjustment plate, Installation manual			

KTBJ25K36W · 56W · 80W · 160W - Service access panel



Dimensions

Unit: mm

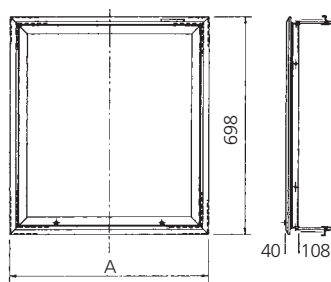

Model	A	Ceiling opening
KTBJ25K36W	626	606 × 680
KTBJ25K56W	776	756 × 680
KTBJ25K80W	1,076	1,056 × 680
KTBJ25K160W	1,476	1,456 × 680

- The inspection hatch can be made to look nice with the service access panel.
- Thin 10 mm design for the exposed part.

Item	Model	KTBJ25K36W	KTBJ25K56W	KTBJ25K80W	KTBJ25K160W
Color		White			
Accessories		Installation manual			
Weight (kg)		6.0	6.5	9.0	10.7

Precautions for Use

- Ceiling joist and ceiling joist support required. (Field supplied.)

KWC26B160 · 280 · 450 - Central drain pan kit



Dimensions

Unit: mm

Model	AA
KWC26B280	930
KWC26B450	1240

KWC26B160

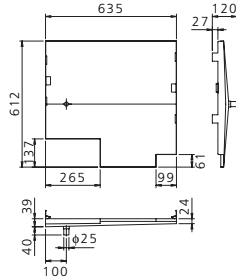

KWC26B280-450

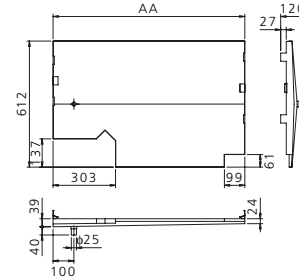

Item	Model	KWC26B160	KWC26B280	KWC26B450
Material		Hot-dip zinc-coated carbon steel sheet for painting		
Weight (kg)		4.0	5.5	7.0

2

YAFM323F15 · 25 · 35 · 50 · 65 · 100 - High efficiency filter

High efficiency filter

Part No.	Applicable Model	Q'ty / Set	Required set
YAFM323F15	VAM150FA	1	1
YAFM323F25	VAM250FA	1	1
YAFM323F35	VAM350FA	2	1
YAFM323F50	VAM500FA	2	1
YAFM323F65	VAM650FA, VAM800FA	2	1
	VAM1500FA		2
YAFM323F100	VAM1000FA	2	1
	VAM2000FA		2

Dimension

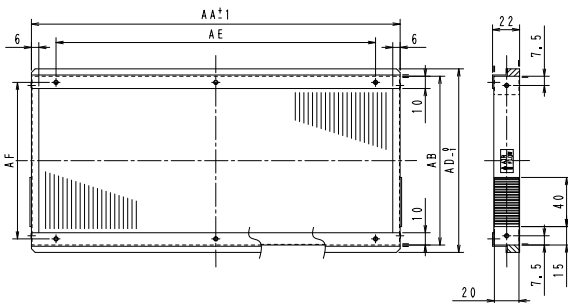

Dimension table [mm]

Part No.	AA	AB
YAFM323F15	362	138
YAFM323F25	435	138
YAFM323F35	311	152
YAFM323F50	363	152
YAFM323F65	379	193
YAFM323F100	508	193

Specification

Filters material	Non woven cloth
Available conditions	Ambient temperature (0 – 50 C) Relative humidity (40 – 95%)
Initial pressure loss	24.5 Pa (2.5 mmH ₂ O) or less.
Final pressure loss	78.4 Pa (8 mmH ₂ O) or less.
Average dust collecting efficiency	65% (Colorimetric method)
Life time	Over 2500 hours (Outdoor dust density: 0.15 mg / m ³)
VAM1500, 2000 need 2 sets per one unit.	

2

YDFA25A1 - Duct adapter



Dimensions

Unit: mm

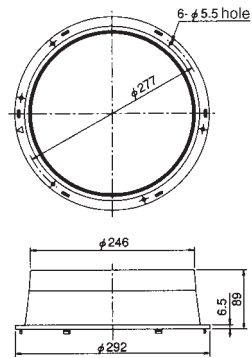

Item	Model	YDFA25A1
Material		Resin (Hi-PS)

Index **3**

Index	Availability
BEVQ100MA	
BEVQ125MA	
BEVQ71MA	
BHFP22MA56	On request
BHFP22MA84	On request
BHFP26MA56	On request
BHFP26MA84	On request
BHFQ22P1007	
BHFQ22P1517	
BHFQ23M135	
BHFQ23M90	
BPMKS967A2	
BPMKS967A3	
BRC1A62	On request
BRC1D52	
BRC2A51	On request
BRC301B61	
BRC3A61	On request
BRC4C61	
BRC4C62	
BRC4C63	On request
BRC4C64	On request
BRC7C510	On request
BRC7C511	On request
BRC7C512	
BRC7C513	
BRC7C528	
BRC7C529	On request
BRC7C62	On request
BRC7C67	On request
BRC7E51	
BRC7E530	
BRC7E531	
BRC7E618	
BRC7E619	
BRC7E63	
BRC7E66	On request
BRP4A50	
BSVQ100M	
BSVQ160M	
BSVQ250M	
BWU26A15	On request
BWU26A20	On request
BYBC125G	
BYBC32G	
BYBC50G	
BYBC63G	
BYBS125D	
BYBS32D	
BYBS45D	
BYBS71D	
BYC125K	
BYCP125DJW1	
BYFQ60B	
BYK45F	
BYK71F	
DAM002A51	On request
DAM003A51	On request
DAM004A51	On request
DAM101A51	On request
DAM411B51	On request
DAM412B51	On request
DAM602B51	On request
DAM602B52	On request
DCS002C51	On request
DCS004A51	On request
DCS301B51	
DCS301B61	On request
DCS302C51	

Index	Availability
DCS302C61	On request
DCS601C51	
DEC101A51	On request
DEC102A51	On request
DMS502A51	On request
DMS504B51	On request
DPC001B51	On request
DST301B51	
DTA102A52	
DTA104A51	On request
DTA104A52	On request
DTA104A53	On request
DTA104A61	On request
DTA104A62	On request
DTA109A51	On request
DTA112B51	
DTA113B51	On request
EKEXDCBA	
EKEXFCBA	
EKEXV100	
EKEXV125	
EKEXV140	
EKEXV200	
EKEXV250	
EKEXV63	
EKEXV80	
EKRORO	
EKRP1B2	On request
KAC972A4E	
KAF241G100M	On request
KAF241G80M	On request
KAF242G100M	On request
KAF242G80M	On request
KAF495FA140	On request
KAF501DA112	On request
KAF501DA160	On request
KAF501DA56	On request
KAF918A43	On request
KAF918A44	On request
KAF918A45	On request
KAF918A46	On request
KAF925B41	On request
KAF925B42	On request
KAF952B41	On request
KAF952B42	On request
KAF963A43	On request
KAF970A46	On request
KAF972A4E	
KAF974B42S	On request
KAFJ252L160	On request
KAFJ252L36	On request
KAFJ252L56	On request
KAFJ252L80	On request
KAFJ253L160	On request
KAFJ253L36	On request
KAFJ253L56	On request
KAFJ253L80	On request
KAFJ371L140	On request
KAFJ371L280	On request
KAFJ372L140	On request
KAFJ372L280	On request
KAFJ373L140	On request
KAFJ373L280	On request
KAFJ501DA80	On request
KAFJ521F56	On request
KAFJ521F80	On request
KAJ25L160B	On request
KAJ25L160D	On request
KAJ25L36B	On request

Index	Availability
KAJ25L36D	On request
KAJ25L56B	On request
KAJ25L56D	On request
KAJ25L80B	On request
KAJ25L80D	On request
KAZ917B41	On request
KAZ917B42	On request
KDAJ25K140	
KDAJ25K36	
KDAJ25K56	
KDAJ25K71	
KDBH44BA60	On request
KDBH49FA80	On request
KDBHJ49F140	On request
KDBHJ55B160	On request
KDBHJ55K160	On request
KDBJ52F56W	On request
KDBJ52F80W	On request
KDBP55H160W	On request
KDBQ44B60	On request
KDBTJ49F140	On request
KDBTJ49F80	On request
KDD55DA160K	On request
KDDJ55B160-2	On request
KDDM24B100	On request
KDDP55D160	On request
KDDP55D160-1	On request
KDDQ44XA60	On request
KDGF19A45	On request
KDGI49F140	On request
KDGI49F80	On request
KDJ3705L140	On request
KDJ3705L280	On request
KDU30L125	On request
KDU30L250	On request
KDU50M125	On request
KDU50M60	On request
KEK26-1A	On request
KFDJ52F56	On request
KFDJ52F80	On request
KHFP49MA140	On request
KHFP5M35	On request
KHFP5M63	On request
KHFP5MA160	On request
KHRP127HB	
KHRQ127H	
KHRQ22M20T	
KHRQ22M20TA	
KHRQ22M29H	
KHRQ22M29T9	
KHRQ22M64H	
KHRQ22M64T	
KHRQ22M75H	
KHRQ22M75T	
KHRQ23M20T	
KHRQ23M29H	
KHRQ23M29T	
KHRQ23M64H	
KHRQ23M64T	
KAFJ521F80	On request
KAJ25L160B	On request
KAJ25L160D	On request
KAJ25L36B	On request
KAJ25L36D	On request
KAJ25L56B	On request

Index	Availability
KAJ25L56D	On request
KAJ25L80B	On request
KKF917AA4	On request
KKF936A4	On request
KKP937A4	On request
KKPJ5F180	
KPBJ52F56	On request
KPBJ52F80	On request
KPMH974A402	On request
KPMH942A42	On request
KPMH950A4L	On request
KPMJ942A4	On request
KPW937A4	On request
KPW945A4	On request
KRC19-26	
KRC72	On request
KRCS01-1	
KRP1B2	On request
KRP1B3	On request
KRP1B54	On request
KRP1B57	On request
KRP1B59	On request
KRP1B61	On request
KRP1B93	
KRP1B96	On request
KRP1B97	On request
KRP1BA101	On request
KRP1C93	On request
KRP1C98	On request
KRP1D98	On request
KRP2A51	
KRP2A52	
KRP2A53	On request
KRP2A61	On request
KRP2A62	On request
KRP413A1S	
KRP4A51	On request
KRP4A52	On request
KRP4A53	
KRP4A54	On request
KRP4A92	On request
KRP4A93	On request
KRP50-2	On request
KRP50-2A90	On request
KRP58M51	On request
KRP928A2S	On request
KSA-25K160	On request
KSA-25K36	On request
KSA-25K56	On request
KSA-25KA80	On request
KTBJ25K160W	On request
KTBJ25K36W	On request
KTBJ25K56W	On request
KTBJ25K80W	On request
KWC26B160	On request
KWC26B280	On request
KWC26B450	On request
YAFM323F100	On request
YAFM323F15	On request
YAFM323F25	On request
YAFM323F35	On request
YAFM323F50	On request
YAFM323F65	On request
YDFA25A1	On request

Remark:
If 'Availability' is left blank the accessory will be in stock.

Accessory Handbook

"The present publication is drawn up by way of information only and does not constitute an offer binding upon Daikin Europe N.V.. Daikin Europe N.V. has compiled the content of this publication to the best of its knowledge. No express or implied warranty is given for the completeness, accuracy, reliability or fitness for particular purpose of its content and the products and services presented therein. Specifications are subject to change without prior notice. Daikin Europe N.V. explicitly rejects any liability for any direct or indirect damage, in the broadest sense, arising from or related to the use and/or interpretation of this publication. All content is copyrighted by Daikin Europe N.V.."



ISO14001 assures an effective environmental management system in order to help protect human health and the environment from the potential impact of our activities, products and services and to assist in maintaining and improving the quality of the environment.



Daikin units comply with the European regulations that guarantee the safety of the product.



Daikin Europe N.V. is approved by LRQA for its Quality Management System in accordance with the ISO9001 standard. ISO9001 pertains to quality assurance regarding design, development, manufacturing as well as to services related to the product.

DAIKIN EUROPE N.V.

Naamloze Vennoetschap
Zandvoordestraat 300
B-8400 Oostende, Belgium
www.daikin.eu
BTW: BE 0412 120 336
RPR Oostende

