

Cooling Capacity:  
88,000 — 116,000 BTU/h

Heating Capacity (Output):  
144,000 BTU/h

7½- TO 10-TON THREE-PHASE  
PACKAGED GAS/ ELECTRIC  
UP TO 11.3 EER / 80% AFUE

### ■ Contents

Nomenclature.....	2
Product Specifications.....	3
Expanded Cooling Data .....	4
Airflow Data.....	10
Dimensions .....	13
Wiring Diagrams .....	17
Accessories .....	19



### ■ Standard Features

- R-410A chlorine-free refrigerant
- TuffTube™ tubular heat exchanger
- High-efficiency scroll compressors
- Two-stage heating and cooling
- Copper tube / aluminum fin coils
- Power block for field wiring
- High-capacity, steel-cased filter drier
- Single-point entry
- 24-volt terminal strip
- Convertible airflow orientation
- Built-in filter rack with standard 2" filters
- Complies with California Low NOx emissions standards

### ■ Cabinet Features

- Heavy-gauge, galvanized-steel cabinet with UV-resistant powder-paint finish
- Full perimeter rail
- Sloped drain pan
- Easy to service



# NOMENCLATURE

	D	C	G	090	300	5	B	*	*	*	A	*	
	1	2	3	4,5,6	7,8,9	10	11	12	13	14	15	16	
<b>Brand</b>												<b>Revision Levels</b>	
D Daikin												Major & Minor	
<b>Configuration</b>												<b>Factory-Installed Options</b>	
C Commercial												X No Options	
<b>Application</b>												<b>Factory-Installed Options</b>	
C Cooling												X Standard Aluminized Heat Exchanger	
G Gas Heat												S Stainless-Steel Heat Exchanger	
H Heat Pump												<b>Factory-Installed Options</b>	
												X No Options	
<b>Nominal Cooling Capacity</b>												<b>Supply Fan/Drive Type/Motor</b>	
036 3 Tons	102	8½ Tons											B Belt Drive
048 4 Tons	120	10 Tons											
060 5 Tons	180	15 Tons											
072 6 Tons	240	20 Tons											
090 7½ Tons													
<b>Nominal Heating Capacity</b>												<b>Voltage</b>	
												1 208-230/1/60	
												4 460/3/60	
												3 208-230/3/60	
												5 400/3/50	
<b>Gas/Electric</b>												<b>A/C H/P Factory-Installed Electric Heat</b>	
180 180,000 BTU/h	XXX	No Heat	030	30 kW									
300 300,000 BTU/h	016	15 kW	045	44 kW									
350 350,000 BTU/h													
See product specifications for heat size(s) available for each capacity.													

PRODUCT SPECIFICATIONS

	DCG090 1805B***A*	DCG102 1805B***A*	DCG120 1805B***A*
<b>COOLING CAPACITY</b>			
Total BTU/h	88,000	97,000	116,000
Sensible BTU/h	65,100	70,380	84,700
EER / IEER	11.3 / 11.5	11.3 / 11.2	11.3 / 11.5
Decibels	82	83	83
AHRI Reference #s	NA	NA	NA
<b>HEATING CAPACITY</b>			
High Input / Output MBTU/h	180,000/144,000	180,000/144,000	180,000/144,000
Low Input / Output MBTU/h	135,000/108,000	135,000/108,000	135,000/108,000
Steady-State Efficiency (AFUE)	80	80	80
Temperature Rise Range (°F)	35 - 65	20-50	20-50
No. of Burners	6	6	6
<b>EVAPORATOR MOTOR / COIL</b>			
Motor Type	Belt Drive	Belt Drive	Belt Drive
Indoor Nominal CFM	3,000	3,200	3,500
FLA (Cooling)	4.6	4.6	4.6
Horsepower / RPM	3.0 - 1,725	3.0 - 1,725	3.0 - 1,725
Piston Size (Cooling)	0.076	0.078	0.086
(#) Filter Size	(4) 16" x 20" x 2"	(4) 16" x 24" x 2"	(4) 16" x 24" x 2"
Drain Size (NPT)	¾"	¾"	¾"
R-410A Refrigerant Charge: Cir #1 / #2 (oz.)	93/93	115/115	115/115
Evaporator Coil Face Area (ft²)	8.9	10.2	10.2
Rows Deep / Fins per Inch	4 / 16	4 / 14	4 / 14
<b>BELT DRIVE EVAP FAN DATA</b>			
# of Wheels (D x W)	1 (15" x 12")	1 (15" x 15")	(1) 15" x 15"
Motor / Blower Sheave	VL40 / AK59	VL40 / AK59	VL40 / AK59
Belt	AX48	AX46	AX46
<b>CONDENSER FAN / COIL</b>			
Quantity of Condenser Fan Motors	2	2	2
Horsepower - RPM	½ - 1,050	½ - 1,050	½ - 1,050
Fan Diameter / # Fan Blades	22 / 3	22 / 3	22 / 3
Outdoor Nominal CFM	7,200	7,200	7,200
Face Area (ft²)	28.8	35.2	35.2
Rows Deep / Fins per Inch	2 X2 / 27±1	2 X2 / 27±1	'2 X2 / 27±1
<b>COMPRESSOR</b>			
Quantity / Type / Stage	2 / Scroll / 1	2 / Scroll / 1	2 / Scroll / 1
Compressor RLA / LRA	6.3/55.0	7.8/52.0	10.9/64.0
<b>ELECTRICAL DATA</b>			
Voltage / Phase	400 / 3 / 50	400 / 3 / 50	400 / 3 / 50
Max External Static	1.0"	1.0"	1.0"
Outdoor Fan HP / RLA	½ / .85 (2)	½ / .85 (2)	½ / .85 (2)
Total Unit Amps	18.9	21.9	28.1
Min. Circuit Ampacity <sup>1</sup>	20.5	23.9	30.8
Max. Overcurrent Protection (amps) <sup>2</sup>	25	30	40
Entrance Power Supply & Control Voltage	Locating Dimple	Locating	Locating Dimple
<b>OPERATING WEIGHT (LBS)</b>	1100	1140	1140
<b>SHIP WEIGHT (LBS)</b>	1175	1215	1215

<sup>1</sup> Wire size should be determined in accordance with National Electrical Codes. Extensive wire runs will require larger wire sizes.

<sup>2</sup> May use fuses or HACR-type circuit breakers of the same size as noted.

Note: Always check the S&R plate for electrical data on the unit being installed.

# COOLING DATA — 7½ TONS

IDB		OUTDOOR AMBIENT TEMPERATURE																																		
		65				75				85				95				105				115														
		59	63	67	71	59	63	67	71	59	63	67	71	59	63	67	71	59	63	67	71	59	63	67	71											
		ENTERING INDOOR WET BULB TEMPERATURE																																		
		AIRFLOW	59	63	67	71	59	63	67	71	59	63	67	71	59	63	67	71	59	63	67	71	59	63	67	71	59	63	67	71						
70	MBh	86	89	98	-	-	82	85	93	-	-	80	83	91	-	-	80	83	91	-	-	80	83	91	-	-	76	79	87	-	-	71	73	80	-	-
	S/T	0.74	0.62	0.43	-	-	0.79	0.66	0.46	-	-	0.82	0.68	0.47	-	-	0.82	0.68	0.47	-	-	0.82	0.68	0.47	-	-	0.85	0.71	0.49	-	-	0.85	0.71	0.49	-	-
	ΔT	17.5	15.1	11.5	-	-	17.7	15.3	11.6	-	-	17.8	15.4	11.7	-	-	17.8	15.4	11.7	-	-	17.8	15.4	11.7	-	-	17.6	15.2	11.5	-	-	16.4	14.2	10.8	-	-
	kW	6.1	6.2	6.4	-	-	6.6	6.7	6.9	-	-	7.3	7.4	7.7	-	-	7.3	7.4	7.7	-	-	7.3	7.4	7.7	-	-	7.6	7.7	8.0	-	-	7.8	8.0	8.2	-	-
	Hi PR	234	252	266	-	-	262	282	298	-	-	340	366	386	-	-	340	366	386	-	-	340	366	386	-	-	382	411	434	-	-	422	454	480	-	-
Lo PR	108	115	126	-	-	114	122	133	-	-	119	126	138	-	-	125	133	145	-	-	125	133	145	-	-	131	139	152	-	-	135	144	157	-	-	
3000	MBh	84	87	95	-	-	80	83	91	-	-	78	81	88	-	-	78	81	88	-	-	78	81	88	-	-	74	77	84	-	-	69	71	78	-	-
	S/T	0.71	0.59	0.41	-	-	0.75	0.63	0.44	-	-	0.78	0.65	0.45	-	-	0.78	0.65	0.45	-	-	0.78	0.65	0.45	-	-	0.81	0.67	0.47	-	-	0.81	0.68	0.47	-	-
	ΔT	18.2	15.7	11.9	-	-	18.4	16.0	12.1	-	-	18.6	16.1	12.2	-	-	18.6	16.1	12.2	-	-	18.6	16.1	12.2	-	-	18.3	15.8	12.0	-	-	17.1	14.8	11.2	-	-
	kW	6.1	6.2	6.4	-	-	6.5	6.6	6.8	-	-	7.2	7.4	7.6	-	-	7.2	7.4	7.6	-	-	7.2	7.4	7.6	-	-	7.5	7.7	7.9	-	-	7.8	7.9	8.2	-	-
	Hi PR	231	249	263	-	-	260	279	295	-	-	336	362	382	-	-	336	362	382	-	-	336	362	382	-	-	378	407	430	-	-	418	450	475	-	-
Lo PR	107	114	124	-	-	113	120	132	-	-	124	132	144	-	-	124	132	144	-	-	124	132	144	-	-	130	138	150	-	-	134	143	156	-	-	
2400	MBh	77	80	88	-	-	74	76	84	-	-	72	75	82	-	-	72	75	82	-	-	72	75	82	-	-	68	71	78	-	-	63	66	72	-	-
	S/T	0.68	0.57	0.40	-	-	0.71	0.59	0.41	-	-	0.75	0.63	0.43	-	-	0.75	0.63	0.43	-	-	0.75	0.63	0.43	-	-	0.78	0.65	0.45	-	-	0.78	0.66	0.45	-	-
	ΔT	20.2	17.5	13.3	-	-	20.5	17.7	13.5	-	-	20.6	17.9	13.6	-	-	20.6	17.9	13.6	-	-	20.6	17.9	13.6	-	-	20.4	17.6	13.4	-	-	19.0	16.5	12.5	-	-
	kW	5.9	6.1	6.2	-	-	6.4	6.5	6.7	-	-	7.1	7.2	7.4	-	-	7.1	7.2	7.4	-	-	7.1	7.2	7.4	-	-	7.3	7.5	7.7	-	-	7.6	7.7	8.0	-	-
	Hi PR	224	242	255	-	-	252	271	286	-	-	326	351	371	-	-	326	351	371	-	-	326	351	371	-	-	367	395	417	-	-	406	436	461	-	-
Lo PR	104	111	121	-	-	110	117	128	-	-	120	128	139	-	-	120	128	139	-	-	120	128	139	-	-	126	134	146	-	-	130	138	151	-	-	
3375	MBh	88	90	98	105	102	86	88	95	102	100	84	86	93	100	97	82	84	91	98	95	82	84	91	98	95	77	80	86	93	90	72	74	80	86	83
	S/T	0.84	0.76	0.57	0.4	0.4	0.88	0.78	0.59	0.4	0.4	0.90	0.80	0.61	0.4	0.4	0.93	0.83	0.63	0.4	0.4	0.93	0.83	0.63	0.4	0.4	0.96	0.86	0.65	0.4	0.4	0.97	0.87	0.66	0.4	0.4
	ΔT	20.2	18.6	15.2	10.5	10.6	20.4	18.8	15.4	10.6	10.7	20.5	18.8	15.4	10.7	10.7	20.6	19.0	15.5	10.7	10.7	20.6	19.0	15.5	10.7	10.7	20.3	18.7	15.3	10.6	10.6	19.0	17.5	14.3	9.9	9.9
	kW	6.2	6.3	6.5	6.7	6.7	6.6	6.7	6.9	7.2	7.2	7.0	7.1	7.4	7.6	7.6	7.3	7.5	7.7	8.0	8.0	7.3	7.5	7.7	8.0	8.0	7.6	7.8	8.0	8.3	8.3	7.9	8.1	8.3	8.6	8.6
	Hi PR	236	254	268	280	280	265	285	301	314	314	301	324	342	357	357	343	369	390	407	407	343	369	390	407	407	386	415	439	458	458	427	459	485	506	506
Lo PR	109	116	127	135	135	116	123	134	143	143	120	128	139	149	149	126	134	146	156	156	126	134	146	156	156	132	141	154	163	163	137	145	159	169	169	
75	MBh	85	88	95	102	99	83	86	93	99	97	81	84	90	97	94	79	82	88	95	92	79	82	88	95	92	75	77	84	90	87	70	72	78	83	83
	S/T	0.81	0.72	0.55	0.4	0.4	0.84	0.75	0.57	0.4	0.4	0.86	0.77	0.58	0.4	0.4	0.88	0.79	0.60	0.4	0.4	0.88	0.79	0.60	0.4	0.4	0.92	0.82	0.62	0.4	0.4	0.93	0.83	0.63	0.4	0.4
	ΔT	21.0	19.4	15.9	11.0	11.1	21.3	19.6	16.1	11.1	11.1	21.3	19.6	16.1	11.1	11.1	21.5	19.8	16.2	11.2	11.2	21.5	19.8	16.2	11.2	11.2	21.2	19.5	16.0	11.0	11.0	19.8	18.2	14.9	10.3	10.3
	kW	6.1	6.2	6.4	6.6	6.6	6.6	6.7	6.9	7.1	7.1	6.9	7.1	7.3	7.5	7.5	7.3	7.4	7.7	7.9	7.9	7.3	7.4	7.7	7.9	7.9	7.6	7.7	8.0	8.2	8.2	7.8	8.0	8.2	8.5	8.5
	Hi PR	234	252	266	277	277	262	282	298	311	311	298	321	339	354	354	340	366	386	403	403	340	366	386	403	403	382	411	434	453	453	422	454	480	501	501
Lo PR	108	115	126	134	134	114	122	133	141	141	119	126	138	147	147	125	133	145	154	154	125	133	145	154	154	131	139	152	162	162	135	144	157	167	167	
2400	MBh	79	81	88	94	92	77	79	86	92	90	75	77	84	90	87	73	75	81	87	84	73	75	81	87	84	69	72	77	83	83	64	66	72	77	77
	S/T	0.78	0.69	0.53	0.3	0.3	0.81	0.72	0.55	0.4	0.4	0.83	0.74	0.56	0.4	0.4	0.85	0.76	0.58	0.4	0.4	0.85	0.76	0.58	0.4	0.4	0.88	0.79	0.60	0.4	0.4	0.89	0.80	0.60	0.4	0.4
	ΔT	23.4	21.5	17.6	12.2	12.3	23.7	21.8	17.9	12.3	12.3	23.7	21.8	17.9	12.3	12.3	23.9	22.0	18.0	12.4	12.4	23.9	22.0	18.0	12.4	12.4	23.5	21.7	17.8	12.3	12.3	22.0	20.2	16.6	11.5	11.5
	kW	6.0	6.1	6.3	6.5	6.5	6.4	6.5	6.7	6.9	6.9	6.8	6.9	7.1	7.4	7.4	7.1	7.3	7.5	7.7	7.7	7.1	7.3	7.5	7.7	7.7	7.4	7.5	7.8	8.0	8.0	7.6	7.8	8.0	8.3	8.3
	Hi PR	227	244	258	269	269	254	274	289	302	302	289	311	329	343	343	330	355	375	391	391	330	355	375	391	391	371	399	421	439	439	410	441	466	486	486
Lo PR	105	112	122	130	130	111	118	129	137	137	115	123	134	143	143	121	129	141	150	150	121	129	141	150	150	127	135	147	157	157	131	140	153	162	162	

IDB: Entering Indoor Dry Bulb Temperature  
 High and low pressures are measured at the liquid and suction access fittings.  
 Shaded area reflects ACCA (TVA) Rating Conditions  
 Design Superheat 7±2 °F, Design Subcooling 12 ±2 °F pressures measured @ the suction and liquid service ports, AHRI 95 test conditions  
 Amps: Unit amps (comp.+ evaporator + condenser fan motors)

# COOLING DATA — 7½ TONS (CONT.)

IDB		OUTDOOR AMBIENT TEMPERATURE																											
		65				75				85				95				105				115							
		59	63	67	71	59	63	67	71	59	63	67	71	59	63	67	71	59	63	67	71	59	63	67	71				
		ENTERING INDOOR WET BULB TEMPERATURE																											
3375	MBh	89	91	97	104	87	89	95	102	85	87	93	99	83	85	91	97	81	82	88	94	77	78	84	89	71	72	77	83
	S/T	0.93	0.87	0.71	0.5	0.96	0.90	0.73	0.5	1.00	0.92	0.75	0.6	1.00	0.95	0.78	0.6	1.00	0.91	0.74	0.55	1.00	0.94	0.77	0.57	1.00	0.95	0.77	0.58
	ΔT	22.5	21.6	18.8	15.0	22.8	21.9	19.0	15.2	23.2	21.9	19.0	15.2	22.6	22.0	19.2	15.3	22.6	22.0	19.2	15.3	23.5	22.6	19.7	15.7	21.7	21.1	18.4	14.7
	kW	6.2	6.3	6.5	6.7	6.7	6.8	7.0	7.2	7.1	7.2	7.4	7.6	7.4	7.6	7.8	8.0	7.7	7.9	8.1	8.4	7.7	7.9	8.1	8.4	7.9	8.1	8.4	8.6
	Hi PR	238	257	271	283	268	288	304	317	304	328	346	361	347	373	394	411	390	420	443	462	386	415	439	458	427	459	485	506
Lo PR	110	118	128	137	117	124	136	144	121	129	141	150	127	136	148	158	134	142	155	165	132	141	154	164	137	145	159	169	
80	MBh	87	89	95	101	85	86	92	99	83	84	90	96	81	82	88	94	81	82	88	94	77	78	84	89	71	72	77	83
	S/T	0.88	0.83	0.67	0.50	0.92	0.86	0.70	0.52	0.94	0.88	0.72	0.54	0.97	0.91	0.74	0.55	0.97	0.91	0.74	0.55	1.00	0.94	0.77	0.57	1.00	0.95	0.77	0.58
	ΔT	23.5	22.5	19.6	15.6	23.8	22.8	19.8	15.8	23.8	22.8	19.8	15.8	23.9	22.9	20.0	15.9	23.9	22.9	20.0	15.9	23.5	22.6	19.7	15.7	21.7	21.1	18.4	14.7
	kW	6.2	6.3	6.5	6.7	6.6	6.7	6.9	7.2	7.0	7.1	7.4	7.6	7.3	7.5	7.7	8.0	7.3	7.5	7.7	8.0	7.6	7.8	8.0	8.3	7.9	8.1	8.3	8.6
	Hi PR	236	254	268	280	265	285	301	314	301	324	342	357	343	369	390	407	343	369	390	407	386	415	439	458	427	459	485	506
Lo PR	109	116	127	135	116	123	134	143	120	128	139	149	126	134	147	156	126	134	147	156	132	141	154	164	137	145	159	169	
2400	MBh	80	82	87	93	78	80	85	91	76	78	83	89	74	76	81	87	74	76	81	87	71	72	77	82	65	67	71	76.4
	S/T	0.85	0.80	0.65	0.5	0.88	0.83	0.67	0.5	0.91	0.85	0.69	0.5	0.93	0.88	0.71	0.5	0.93	0.88	0.71	0.5	0.97	0.91	0.74	0.6	0.98	0.92	0.75	0.6
	ΔT	26.1	25.0	21.8	17.4	26.4	25.3	22.0	17.6	26.5	25.4	22.0	17.6	26.6	25.5	22.2	17.7	26.6	25.5	22.2	17.7	26.3	25.2	21.9	17.5	24.5	23.5	20.4	16.3
	kW	6.0	6.1	6.3	6.5	6.5	6.6	6.8	7.0	6.8	7.0	7.2	7.4	7.2	7.3	7.5	7.8	7.2	7.3	7.5	7.8	7.5	7.6	7.8	8.1	7.7	7.9	8.1	8.4
	Hi PR	229	246	260	271	257	277	292	305	292	315	332	346	333	358	378	395	333	358	378	395	375	403	426	444	414	445	470	490
Lo PR	106	113	123	131	112	119	130	139	116	124	135	144	122	130	142	151	122	130	142	151	128	136	149	159	133	141	154	164	
3375	MBh	91	93	97	103	89	90	95	101	87	88	92	99	84	86	90	96	84	86	90	96	80	82	86	91	74	76	79	85
	S/T	0.97	0.94	0.85	0.7	1.00	0.97	0.88	0.7	1.00	0.95	0.86	0.7	1.00	0.98	0.89	0.8	1.00	1.00	0.93	0.8	1.00	1.00	0.96	0.8	1.00	1.00	0.97	0.8
	ΔT	24.0	23.6	22.3	19.3	24.2	23.9	22.6	19.6	23.6	24.0	22.6	19.6	23.0	23.5	22.8	19.7	23.0	23.5	22.8	19.7	21.9	22.3	22.5	19.5	20.3	20.6	21.0	18.2
	kW	6.3	6.4	6.6	6.8	6.7	6.8	7.1	7.3	7.1	7.3	7.5	7.7	7.5	7.6	7.8	8.1	7.5	7.6	7.8	8.1	7.8	7.9	8.2	8.4	8.0	8.2	8.4	8.7
	Hi PR	241	259	274	285	270	291	307	320	307	331	349	364	350	377	398	415	350	377	398	415	394	424	448	467	435	468	495	516
Lo PR	112	119	130	138	118	125	137	146	122	130	142	152	129	137	149	159	129	137	149	159	135	143	157	167	139	148	162	173	
85	MBh	88	90	94	100	86	88	92	98	84	86	90	96	82	84	88	93	82	84	88	93	78	79	83	89	72	74	77	82
	S/T	0.93	0.89	0.81	0.7	0.96	0.93	0.84	0.7	0.98	0.95	0.86	0.7	1.00	0.98	0.89	0.7	1.00	1.00	0.92	0.7	1.00	1.00	0.92	0.7	1.00	1.00	0.93	0.8
	ΔT	25.0	24.6	23.3	20.1	25.3	24.9	23.6	20.4	25.4	24.9	23.6	20.4	25.1	25.1	23.7	20.6	25.1	25.1	23.7	20.6	23.9	24.3	23.4	20.3	22.1	22.5	21.9	18.9
	kW	6.2	6.3	6.5	6.7	6.7	6.8	7.0	7.2	7.1	7.2	7.4	7.6	7.4	7.6	7.8	8.0	7.4	7.6	7.8	8.0	7.7	7.9	8.1	8.4	7.9	8.1	8.4	8.6
	Hi PR	238	257	271	283	268	288	304	317	304	328	346	361	347	373	394	411	347	373	394	411	390	420	443	462	431	464	490	511
Lo PR	110	118	128	137	117	124	136	144	121	129	141	150	127	136	148	158	127	136	148	158	134	142	155	165	138	147	160	171	
2400	MBh	81	83	87	93	79	81	85	91	78	79	83	88	76	77	81	86	76	77	81	86	72	73	77	82	67	68	71	75.9
	S/T	0.89	0.86	0.78	0.6	0.93	0.89	0.81	0.7	0.95	0.92	0.83	0.7	0.98	0.95	0.85	0.7	1.00	0.98	0.89	0.7	1.00	0.98	0.89	0.7	1.00	0.99	0.89	0.7
	ΔT	27.8	27.4	25.9	22.4	28.2	27.7	26.2	22.7	28.2	27.8	26.2	22.7	28.4	28.0	26.4	22.9	28.4	28.0	26.4	22.9	27.5	27.6	26.0	22.5	25.5	25.7	24.3	21.1
	kW	6.1	6.2	6.4	6.6	6.5	6.6	6.8	7.0	6.9	7.0	7.2	7.5	7.2	7.4	7.6	7.8	7.2	7.4	7.6	7.8	7.5	7.7	7.9	8.2	7.8	7.9	8.2	8.4
	Hi PR	231	249	263	274	260	279	295	308	295	318	335	350	336	362	382	399	336	362	382	399	378	407	430	448	418	450	475	495
Lo PR	107	114	124	133	113	120	131	140	118	125	137	146	124	131	144	153	124	131	144	153	130	138	150	160	134	143	156	166	

IDB: Entering Indoor Dry Bulb Temperature  
 High and low pressures are measured at the liquid and suction access fittings.  
 Shaded area reflects AHRI Rating Conditions  
 Design Superheat 7±2 °F, Design Subcooling 12 ± 2 °F pressures measured @ the suction and liquid service ports, AHRI 95 test conditions  
 Amps: Unit amps (comp.+ evaporator + condenser fan motors)

# COOLING DATA — 8½ TONS

IDB		OUTDOOR AMBIENT TEMPERATURE												ENTERING INDOOR WET BULB TEMPERATURE																
		65				75				85				95				105				115								
		59	63	67	71	59	63	67	71	59	63	67	71	59	63	67	71	59	63	67	71	59	63	67	71					
<b>70</b>	Airflow	MBh	95.1	98.5	107.9	-	92.8	96.2	105.4	-	90.6	93.9	102.9	-	88.4	91.6	100.4	-	84.0	87.1	95.4	-	84.0	87.1	95.4	-	77.8	80.6	88.4	-
		S/T	0.77	0.64	0.44	-	0.80	0.67	0.46	-	0.82	0.68	0.47	-	0.84	0.70	0.49	-	0.88	0.73	0.51	-	0.88	0.73	0.51	-	0.88	0.74	0.51	-
		ΔT	18	15	12	-	18	15	12	-	18	15	12	-	18	16	12	-	18	15	12	-	18	15	12	-	17	14	11	-
	3825	kW	6.46	6.59	6.78	-	6.92	7.06	7.27	-	7.33	7.48	7.71	-	7.69	7.85	8.10	-	8.00	8.17	8.42	-	8.00	8.17	8.42	-	8.26	8.44	8.71	-
		Amps	12.5	12.7	13.0	-	13.2	13.5	13.8	-	14.0	14.3	14.6	-	14.7	15.0	15.4	-	15.4	15.7	16.1	-	15.4	15.7	16.1	-	16.1	16.4	16.8	-
		HI PR	234	252	266	-	262	282	298	-	298	321	339	-	340	366	386	-	382	411	434	-	382	411	434	-	422	454	480	-
	LO PR	108	115	126	-	114	122	133	-	119	126	138	-	125	133	145	-	131	139	152	-	131	139	152	-	135	144	157	-	
		92.3	95.6	104.8	-	90.1	93.4	102.4	-	88.0	91.2	99.9	-	85.8	89.0	97.5	-	81.6	84.5	92.6	-	81.6	84.5	92.6	-	75.5	78.3	85.8	-	
		S/T	0.73	0.61	0.42	-	0.76	0.63	0.44	-	0.78	0.65	0.45	-	0.80	0.67	0.47	-	0.83	0.70	0.48	-	0.83	0.70	0.48	-	0.84	0.70	0.49	-
	3400	ΔT	18	16	12	-	19	16	12	-	19	16	12	-	19	16	12	-	19	16	12	-	19	16	12	-	17	15	11	-
		kW	6.41	6.54	6.73	-	6.87	7.01	7.22	-	7.28	7.42	7.65	-	7.63	7.79	8.03	-	7.94	8.10	8.36	-	7.94	8.10	8.36	-	8.20	8.37	8.64	-
		Amps	12.5	12.7	12.9	-	13.1	13.4	13.7	-	13.9	14.2	14.5	-	14.6	14.9	15.3	-	15.3	15.6	16.0	-	15.3	15.6	16.0	-	16.0	16.3	16.7	-
HI PR	231	249	263	-	260	279	295	-	295	318	336	-	336	362	382	-	378	407	430	-	378	407	430	-	418	450	475	-		
	107	114	124	-	113	120	132	-	118	125	137	-	124	132	144	-	130	138	150	-	130	138	150	-	134	143	156	-		
	85.2	88.3	96.7	-	83.2	86.2	94.5	-	81.2	84.2	92.2	-	79.2	82.1	90.0	-	75.3	78.0	85.5	-	75.3	78.0	85.5	-	69.7	72.3	79.2	-		
2720	S/T	0.71	0.59	0.41	-	0.73	0.61	0.42	-	0.75	0.63	0.43	-	0.78	0.65	0.45	-	0.80	0.67	0.47	-	0.80	0.67	0.47	-	0.81	0.68	0.47	-	
	ΔT	20	18	13	-	21	18	14	-	21	18	14	-	21	18	14	-	20	18	13	-	20	18	13	-	19	17	13	-	
	kW	6.27	6.39	6.58	-	6.71	6.85	7.05	-	7.11	7.25	7.47	-	7.45	7.61	7.84	-	7.75	7.91	8.16	-	7.75	7.91	8.16	-	8.00	8.17	8.43	-	
HI PR	12.2	12.4	12.7	-	12.9	13.1	13.4	-	13.7	13.9	14.2	-	14.3	14.6	15.0	-	15.0	15.3	15.7	-	15.0	15.3	15.7	-	15.7	16.0	16.4	-		
	224	242	255	-	252	271	286	-	286	308	326	-	326	351	371	-	367	395	417	-	367	395	417	-	406	436	461	-		
	104	111	121	-	110	117	128	-	114	121	133	-	120	128	139	-	126	134	146	-	126	134	146	-	130	138	151	-		
<b>75</b>	Airflow	MBh	96.7	99.5	107.7	115.6	94.4	97.2	105.2	112.9	92.2	94.9	102.7	110.2	89.9	92.6	100.2	107.6	85.4	88.0	95.2	102.2	85.4	88.0	95.2	102.2	79.1	81.5	88.2	94.6
		S/T	0.87	0.78	0.59	0.38	0.91	0.81	0.61	0.39	0.93	0.83	0.63	0.40	0.96	0.86	0.65	0.42	0.99	0.89	0.67	0.43	0.99	0.89	0.67	0.43	1.00	0.90	0.68	0.44
		ΔT	20	19	15	11	21	19	16	11	21	19	16	11	21	19	16	11	20	19	15	11	20	19	15	11	19	18	14	10
	3825	kW	6.51	6.64	6.83	7.04	6.98	7.12	7.33	7.56	7.39	7.54	7.77	8.02	7.75	7.92	8.16	8.42	8.06	8.23	8.49	8.77	8.06	8.23	8.49	8.77	8.33	8.51	8.78	9.06
		Amps	12.6	12.8	13.1	13.5	13.3	13.5	13.9	14.2	14.1	14.4	14.7	15.1	14.8	15.1	15.5	15.9	15.5	15.8	16.2	16.7	15.5	15.8	16.2	16.7	16.2	16.5	17.0	17.5
		HI PR	236	254	268	280	265	285	301	314	301	324	342	357	343	369	390	407	386	415	439	458	386	415	439	458	427	459	485	506
	LO PR	109	116	127	135	116	123	134	143	120	128	139	149	126	134	146	156	132	141	154	163	132	141	154	163	137	145	159	169	
		93.8	96.6	104.6	112.3	91.7	94.4	102.2	109.6	89.5	92.1	99.7	107.0	87.3	89.9	97.3	104.4	82.9	85.4	92.4	99.2	82.9	85.4	92.4	99.2	76.8	79.1	85.6	91.9	
		S/T	0.83	0.75	0.56	0.36	0.86	0.77	0.58	0.38	0.89	0.79	0.60	0.39	0.91	0.82	0.62	0.40	0.95	0.85	0.64	0.41	0.95	0.85	0.64	0.41	0.96	0.86	0.65	0.42
	3400	ΔT	21	19	16	11	21	20	16	11	21	20	16	11	22	20	16	11	21	20	16	11	21	20	16	11	20	18	15	10
		kW	6.46	6.59	6.78	6.99	6.92	7.06	7.28	7.50	7.33	7.48	7.71	7.95	7.69	7.85	8.10	8.36	8.00	8.17	8.43	8.70	8.00	8.17	8.43	8.70	8.27	8.44	8.71	8.99
		Amps	12.5	12.7	13.0	13.4	13.2	13.5	13.8	14.1	14.0	14.3	14.6	15.0	14.7	15.0	15.4	15.8	15.4	15.7	16.1	16.6	15.4	15.7	16.1	16.6	16.1	16.4	16.8	17.3
HI PR	234	252	266	277	262	282	298	311	298	321	339	354	340	366	386	403	382	411	434	453	382	411	434	453	422	454	480	501		
	108	115	126	134	114	122	133	141	119	126	138	147	125	133	145	154	131	139	152	162	131	139	152	162	135	144	157	167		
	86.6	89.2	96.5	103.6	84.6	87.1	94.3	101.2	82.6	85.0	92.0	98.8	80.6	83.0	89.8	96.4	76.5	78.8	85.3	91.6	76.5	78.8	85.3	91.6	70.9	73.0	79.0	84.8		
2720	S/T	0.80	0.72	0.54	0.35	0.83	0.74	0.56	0.36	0.85	0.76	0.58	0.37	0.88	0.79	0.60	0.38	0.91	0.82	0.62	0.40	0.91	0.82	0.62	0.40	0.92	0.83	0.62	0.40	
	ΔT	24	22	18	12	24	22	18	12	24	22	18	12	24	22	18	13	24	22	18	12	24	22	18	12	22	20	17	12	
	kW	6.32	6.44	6.63	6.83	6.77	6.90	7.11	7.33	7.16	7.31	7.53	7.77	7.51	7.67	7.91	8.15	7.81	7.97	8.22	8.49	7.81	7.97	8.22	8.49	8.07	8.24	8.50	8.77	
HI PR	12.3	12.5	12.8	13.1	13.0	13.2	13.5	13.9	13.8	14.0	14.3	14.7	14.4	14.7	15.1	15.5	15.1	15.4	15.8	16.2	15.1	15.4	15.8	16.2	15.8	16.1	16.5	17.0		
	227	244	258	269	254	274	289	302	289	311	329	343	330	355	375	391	371	399	421	439	371	399	421	439	410	441	466	486		
	105	112	122	130	111	118	129	137	115	123	134	143	121	129	141	150	127	135	147	157	127	135	147	157	131	140	153	162		

IDB: Entering Indoor Dry Bulb Temperature  
 High and low pressures are measured at the liquid and suction access fittings.  
 Shaded area reflects ACCA (TVA) Rating Conditions  
 Design Superheat 7±2 °F, Design Subcooling 12 ±2 °F, pressures measured @ the suction and liquid service ports, AHRI 95 test conditions  
 Amps: Unit amps (comp + evaporator + condenser fan motors)

COOLING DATA — 8½ TONS (CONT.)

IDB	AIRFLOW	OUTDOOR AMBIENT TEMPERATURE												ENTERING INDOOR WET BULB TEMPERATURE													
		65				75				85				95				105				115					
		59	63	67	71	59	63	67	71	59	63	67	71	59	63	67	71	59	63	67	71	59	63	67	71		
80	3825	MBh	98.4	100.5	107.4	114.8	96.1	98.2	104.9	112.1	93.8	95.9	102.4	109.5	91.5	93.5	99.9	106.8	86.9	88.8	94.9	101.5	80.5	82.3	87.9	94.0	
		S/T	0.96	0.90	0.73	0.55	1.00	0.93	0.76	0.57	1.00	0.96	0.78	0.58	1.00	1.00	0.80	0.60	1.00	1.00	0.83	0.62	1.00	1.00	0.84	0.63	
	3400	ΔT	23	22	19	15	23	22	19	15	23	22	19	15	22	22	22	15	21	21	19	15	19	20	18	14	
		kW	6.56	6.69	6.88	7.09	7.03	7.17	7.39	7.62	7.45	7.60	7.83	8.08	7.81	7.98	8.23	8.49	8.13	8.30	8.56	8.84	8.40	8.58	8.85	9.14	
	2720	Amps	12.7	12.9	13.2	13.5	13.4	13.6	14.0	14.3	14.2	14.5	14.8	15.2	14.9	15.2	15.6	16.0	15.6	15.9	16.3	16.8	16.4	16.7	17.1	17.6	
		HI PR	238	257	271	283	268	288	304	317	304	328	346	361	347	373	394	411	390	420	443	462	431	464	490	511	
	3825	LO PR	110	118	128	137	117	124	136	144	121	129	141	150	127	136	148	158	134	142	155	165	138	147	160	171	
		MBh	95.5	97.6	104.3	111.5	93.3	95.3	101.9	108.9	91.1	93.1	99.4	106.3	88.9	90.8	97.0	103.7	84.4	86.3	92.2	98.5	78.2	79.9	85.4	91.2	
	85	3825	S/T	0.91	0.86	0.70	0.52	0.95	0.89	0.72	0.54	0.97	0.91	0.74	0.55	1.00	0.94	0.77	0.57	1.00	0.98	0.79	0.59	1.00	0.98	0.80	0.60
			ΔT	24	23	20	16	24	23	20	16	24	23	20	16	24	23	20	16	23	23	20	16	21	21	18	15
3400		kW	6.51	6.64	6.83	7.04	6.98	7.12	7.33	7.56	7.39	7.54	7.77	8.02	7.75	7.92	8.16	8.42	8.06	8.23	8.49	8.77	8.33	8.51	8.78	9.06	
		Amps	12.6	12.8	13.1	13.5	13.3	13.5	13.9	14.2	14.1	14.4	14.7	15.1	14.8	15.1	15.5	15.9	15.5	15.8	16.2	16.7	16.2	16.5	17.0	17.5	
2720		HI PR	236	254	268	280	265	285	301	314	301	324	342	357	343	369	390	407	386	415	439	458	427	459	485	506	
		LO PR	109	116	127	135	116	123	134	143	120	128	139	149	126	134	147	156	132	141	154	164	137	145	159	169	
3825		MBh	88.2	90.1	96.2	102.9	86.1	88.0	94.0	100.5	84.1	85.9	91.8	98.1	82.0	83.8	89.5	95.7	77.9	79.6	85.1	90.9	72.2	73.7	78.8	84.2	
		S/T	0.88	0.83	0.67	0.50	0.91	0.86	0.70	0.52	0.94	0.88	0.71	0.53	0.97	0.91	0.74	0.55	1.00	0.94	0.77	0.57	1.01	0.95	0.77	0.58	
85		3825	ΔT	26	25	22	17	27	25	22	18	27	25	22	18	27	26	22	18	26	25	22	18	25	24	21	16
			kW	6.36	6.49	6.68	6.88	6.82	6.95	7.16	7.38	7.22	7.37	7.59	7.83	7.57	7.73	7.97	8.22	7.87	8.04	8.29	8.55	8.13	8.30	8.57	8.84
	3400	Amps	12.4	12.6	12.9	13.2	13.1	13.3	13.6	14.0	13.9	14.1	14.4	14.8	14.5	14.8	15.2	15.6	15.2	15.5	15.9	16.3	15.9	16.2	16.6	17.1	
		HI PR	229	246	260	271	257	277	292	305	292	315	332	346	333	358	378	395	375	403	426	444	414	445	470	490	
	2720	LO PR	106	113	123	131	112	119	130	139	116	124	135	144	122	130	142	151	128	136	149	159	133	141	154	164	
		MBh	100.1	102.0	106.9	114.0	97.8	99.7	104.4	111.4	95.4	97.3	101.9	108.7	93.1	94.9	99.4	106.1	88.5	90.2	94.4	100.8	81.9	83.5	87.5	93.3	
	85	3825	S/T	1.00	0.97	0.87	0.71	1.00	1.00	0.91	0.74	1.00	1.00	0.93	0.75	1.00	1.00	0.96	0.78	1.00	1.00	1.00	0.81	1.00	1.00	1.00	0.81
			ΔT	24	24	22	19	24	24	23	20	23	23	20	20	22	23	23	20	21	22	23	20	20	20	20	18
		3400	kW	6.60	6.74	6.94	7.15	7.08	7.23	7.45	7.68	7.50	7.66	7.90	8.15	7.88	8.04	8.29	8.56	8.19	8.37	8.63	8.91	8.47	8.65	8.92	9.21
			Amps	12.8	13.0	13.3	13.6	13.5	13.7	14.0	14.4	14.3	14.6	14.9	15.3	15.0	15.3	15.7	16.1	15.8	16.1	16.5	16.9	16.5	16.8	17.2	17.7
2720		HI PR	241	259	274	285	270	291	307	320	307	331	349	364	350	377	398	415	394	424	448	467	435	468	495	516	
		LO PR	112	119	130	138	118	125	137	146	122	130	142	152	129	137	149	159	135	143	157	167	139	148	162	173	
3825		MBh	97.2	99.1	103.8	110.7	94.9	96.8	101.3	108.1	92.7	94.5	98.9	105.5	90.4	92.2	96.5	103.0	85.9	87.5	91.7	97.8	79.6	81.1	84.9	90.6	
		S/T	0.96	0.92	0.83	0.68	0.99	0.96	0.86	0.70	1.00	0.98	0.89	0.72	1.00	1.00	0.92	0.74	1.00	1.00	0.95	0.77	1.00	1.00	0.96	0.78	
85		3825	ΔT	25	25	23	20	25	25	24	21	25	25	24	21	24	25	24	21	23	24	24	20	22	22	22	19
			kW	6.56	6.69	6.88	7.09	7.03	7.17	7.39	7.62	7.45	7.60	7.83	8.08	7.81	7.98	8.23	8.49	8.13	8.30	8.56	8.84	8.40	8.58	8.85	9.14
	3400	Amps	12.7	12.9	13.2	13.5	13.4	13.6	14.0	14.3	14.2	14.5	14.8	15.2	14.9	15.2	15.6	16.0	15.6	15.9	16.3	16.8	16.4	16.7	17.1	17.6	
		HI PR	238	257	271	283	268	288	304	317	304	328	346	361	347	373	394	411	390	420	443	462	431	464	490	511	
	2720	LO PR	110	118	128	137	117	124	136	144	121	129	141	150	127	136	148	158	134	142	155	165	138	147	160	171	
		MBh	89.7	91.4	95.8	102.2	87.6	89.3	93.5	99.8	85.5	87.2	91.3	97.4	83.4	85.1	89.1	95.0	79.3	80.8	84.6	90.3	73.4	74.9	78.4	83.6	
	85	3825	S/T	0.92	0.89	0.80	0.65	0.96	0.92	0.83	0.68	0.98	0.95	0.85	0.69	1.00	0.98	0.88	0.72	1.00	1.00	0.92	0.74	1.00	1.00	0.92	0.75
			ΔT	28	28	26	23	28	28	26	23	28	28	26	23	28	28	27	23	27	27	26	23	25	25	24	21
		3400	kW	6.41	6.54	6.73	6.93	6.87	7.01	7.22	7.44	7.27	7.42	7.65	7.89	7.63	7.79	8.03	8.29	7.93	8.10	8.36	8.62	8.20	8.37	8.64	8.91
			Amps	12.5	12.7	12.9	13.3	13.1	13.4	13.7	14.0	13.9	14.2	14.5	14.9	14.6	14.9	15.3	15.7	15.3	15.6	16.0	16.5	16.0	16.3	16.7	17.2
2720		HI PR	231	249	263	274	260	279	295	308	295	318	335	350	336	362	382	399	378	407	430	448	418	450	475	495	
		LO PR	107	114	124	133	113	120	131	140	118	125	137	146	124	131	144	153	130	138	150	160	134	143	156	166	

IDB: Entering Indoor Dry Bulb Temperature  
 High and low pressures are measured at the liquid and suction access fittings.  
 Shaded area reflects AHRI Rating Conditions  
 Design Superheat 7±2 °F; Design Subcooling 12 ±2 °F; pressures measured @ the suction and liquid service ports, AHRI 95 test conditions  
 Amps: Unit amps (comp + evaporator + condenser fan motors)

# COOLING DATA — 10 TONS

IDB		OUTDOOR AMBIENT TEMPERATURE																											
		65				75				85				95				105				115							
		59	63	67	71	59	63	67	71	59	63	67	71	59	63	67	71	59	63	67	71	59	63	67	71				
		ENTERING INDOOR WET BULB TEMPERATURE																											
AIRFLOW		59	63	67	71	59	63	67	71	59	63	67	71	59	63	67	71	59	63	67	71	59	63	67	71	59	63	67	71
3938	MBh	114	118	129	-	111	115	126	-	108	112	123	-	106	110	120	-	100	104	114	-	93	96	106	-				
	S/T	0.73	0.61	0.42	-	0.76	0.63	0.44	-	0.78	0.65	0.45	-	0.80	0.67	0.47	-	0.83	0.70	0.48	-	0.84	0.70	0.49	-				
	ΔT	19.5	16.8	12.8	-	19.7	17.1	12.9	-	19.7	17.1	13.0	-	19.9	17.2	13.0	-	19.6	16.9	12.9	-	18.3	15.8	12.0	-				
	kW	8.2	8.4	8.6	-	8.8	8.9	9.2	-	9.3	9.4	9.7	-	9.7	9.9	10.2	-	10.0	10.2	10.5	-	10.4	10.6	10.9	-				
70	Hi PR	247	266	281	-	277	298	315	-	315	339	358	-	359	386	408	-	404	435	459	-	446	480	507	-				
	Lo PR	105	111	122	-	111	118	128	-	115	122	134	-	121	128	140	-	127	135	147	-	131	139	152	-				
	MBh	110	114	125	-	108	112	122	-	105	109	119	-	103	106	117	-	98	101	111	-	90	94	103	-				
	S/T	0.70	0.58	0.40	-	0.72	0.61	0.42	-	0.74	0.62	0.43	-	0.77	0.64	0.44	-	0.80	0.66	0.46	-	0.80	0.67	0.46	-				
2800	ΔT	20.3	17.5	13.3	-	20.5	17.8	13.5	-	20.5	17.8	13.5	-	20.7	17.9	13.6	-	20.4	17.7	13.4	-	19.1	16.5	12.5	-				
	kW	8.2	8.3	8.5	-	8.7	8.9	9.1	-	9.2	9.4	9.6	-	9.6	9.8	10.1	-	10.0	10.2	10.5	-	10.3	10.5	10.8	-				
	Hi PR	245	263	278	-	274	295	312	-	312	336	355	-	355	383	404	-	400	430	454	-	442	476	502	-				
	Lo PR	104	110	120	-	110	117	127	-	114	121	132	-	120	127	139	-	125	133	146	-	130	138	151	-				
75	MBh	102	106	116	-	99	103	113	-	97	101	110	-	95	98	108	-	90	93	102	-	83	86	95	-				
	S/T	0.67	0.56	0.39	-	0.70	0.58	0.40	-	0.72	0.60	0.41	-	0.74	0.62	0.43	-	0.77	0.64	0.44	-	0.77	0.65	0.45	-				
	ΔT	22.6	19.5	14.8	-	22.8	19.8	15.0	-	22.9	19.8	15.0	-	23.0	19.9	15.1	-	22.7	19.6	14.9	-	21.2	18.3	13.9	-				
	kW	8.0	8.1	8.4	-	8.5	8.7	8.9	-	9.0	9.2	9.4	-	9.4	9.6	9.9	-	9.7	9.9	10.2	-	10.0	10.2	10.6	-				
3938	Hi PR	237	255	270	-	266	286	302	-	303	326	344	-	345	371	392	-	388	417	441	-	429	461	487	-				
	Lo PR	101	107	117	-	106	113	123	-	110	117	128	-	116	123	135	-	122	129	141	-	126	134	146	-				
	MBh	116	119	129	138	113	116	126	135	110	113	123	132	108	111	120	129	102	105	114	122	95	97	105	113				
	S/T	0.83	0.75	0.56	0.4	0.86	0.77	0.58	0.4	0.89	0.79	0.60	0.4	0.91	0.82	0.62	0.4	0.95	0.85	0.64	0.4	0.96	0.86	0.65	0.4				
3500	ΔT	22.5	20.7	17.0	11.7	22.8	21.0	17.2	11.9	22.8	21.0	17.2	11.9	23.0	21.1	17.3	12.0	22.6	20.8	17.1	11.8	21.1	19.5	15.9	11.0				
	kW	8.3	8.4	8.7	8.9	8.8	9.0	9.3	9.5	9.3	9.5	9.8	10.1	9.8	9.9	10.2	10.5	10.1	10.3	10.6	10.9	10.4	10.6	11.0	11.3				
	Hi PR	250	269	284	296	280	301	318	332	318	343	362	377	363	390	412	430	408	439	464	484	451	485	512	534				
	Lo PR	106	113	123	131	112	119	130	138	116	124	135	144	122	130	142	151	128	136	148	158	132	141	154	164				
75	MBh	112	116	125	134	110	113	122	131	107	110	119	128	104	107	116	125	99	102	111	119	92	95	102	110				
	S/T	0.79	0.71	0.54	0.3	0.82	0.74	0.56	0.4	0.84	0.76	0.57	0.4	0.87	0.78	0.59	0.4	0.90	0.81	0.61	0.4	0.91	0.82	0.62	0.4				
	ΔT	23.4	21.6	17.7	12.2	23.7	21.8	17.9	12.4	23.7	21.9	17.9	12.4	23.9	22.0	18.0	12.5	23.6	21.7	17.8	12.3	22.0	20.3	16.6	11.5				
	kW	8.2	8.4	8.6	8.8	8.8	8.9	9.2	9.5	9.3	9.4	9.7	10.0	9.7	9.9	10.2	10.5	10.0	10.2	10.5	10.9	10.4	10.6	10.9	11.2				
2800	Hi PR	247	266	281	293	277	298	315	329	315	339	358	374	359	386	408	426	404	435	459	479	446	480	507	529				
	Lo PR	105	111	122	130	111	118	128	137	115	122	134	142	121	128	140	149	127	135	147	157	131	139	152	162				
	MBh	104	107	115	124	101	104	113	121	99	102	110	118	96	99	107	115	92	94	102	109	85	87	95	101				
	S/T	0.77	0.69	0.52	0.3	0.79	0.71	0.54	0.3	0.81	0.73	0.55	0.4	0.84	0.75	0.57	0.4	0.87	0.78	0.59	0.4	0.88	0.79	0.60	0.4				
75	ΔT	26.1	24.0	19.7	13.6	26.4	24.3	19.9	13.7	26.4	24.3	19.9	13.8	26.6	24.5	20.1	13.9	26.2	24.2	19.8	13.7	24.5	22.6	18.5	12.8				
	kW	8.1	8.2	8.4	8.7	8.6	8.7	9.0	9.2	9.1	9.2	9.5	9.8	9.5	9.7	9.9	10.2	9.8	10.0	10.3	10.6	10.1	10.3	10.6	11.0				
	Hi PR	240	258	272	284	269	289	306	319	306	329	348	362	348	375	396	413	392	422	445	464	433	466	492	513				
	Lo PR	102	108	118	126	107	114	125	133	112	119	130	138	117	125	136	145	123	131	143	152	127	135	148	157				

IDB: Entering Indoor Dry Bulb Temperature  
 High and low pressures are measured at the liquid and suction access fittings.  
 Shaded area reflects ACCA (TVA) Rating Conditions  
 Design Superheat 7±2 °F, Design Subcooling 12 ±2 °F pressures measured @ the suction and liquid service ports, AHRI 95 test conditions  
 Amps: Unit amps (comp.+ evaporator + condenser fan motors)

# COOLING DATA — 10 TONS (CONT.)

IDB		OUTDOOR AMBIENT TEMPERATURE																																															
		65								75								85								95								105								115							
		59	63	67	71	59	63	67	71	59	63	67	71	59	63	67	71	59	63	67	71	59	63	67	71	59	63	67	71	59	63	67	71																
AIRFLOW		118	120	128	137	115	117	125	134	112	115	122	131	109	112	119	128	104	106	114	121	104	106	114	121	96	98	105	112																				
MBh		0.91	0.86	0.70	0.5	0.95	0.89	0.72	0.5	1.00	0.91	0.74	0.6	1.00	0.94	0.77	0.6	1.00	1.00	0.79	0.6	1.00	1.00	0.79	0.6	1.00	1.00	0.80	0.6																				
S/T		25.1	24.1	20.9	16.7	25.4	24.4	21.2	16.9	26.2	24.4	21.2	16.9	25.6	24.6	21.4	17.1	24.3	24.8	21.1	16.8	22.5	23.0	21.1	16.8	22.5	23.0	19.7	15.7																				
ΔT		8.3	8.5	8.7	9.0	8.9	9.1	9.3	9.6	9.4	9.6	9.8	10.1	9.8	10.0	10.3	10.6	10.2	10.4	10.7	11.0	10.5	10.7	11.0	10.5	10.7	11.0	11.4	11.4																				
kW		252	271	286	299	283	304	321	335	322	346	366	381	366	394	416	434	412	444	468	489	455	490	517	540	455	490	517	540																				
Hi PR		107	114	124	132	113	120	131	140	117	125	136	145	123	131	143	152	129	137	150	160	134	142	155	165	134	142	155	165																				
Lo PR		114	117	125	133	112	114	122	130	109	111	119	127	106	109	116	124	101	103	110	118	94	96	102	109	94	96	102	109																				
MBh		0.87	0.82	0.67	0.50	0.90	0.85	0.69	0.52	0.93	0.87	0.71	0.53	0.96	0.90	0.73	0.55	0.99	0.93	0.76	0.57	1.00	0.94	0.76	0.6	1.00	0.94	0.76	0.6																				
S/T		26.2	25.1	21.8	17.4	26.5	25.4	22.1	17.6	26.5	25.4	22.1	17.6	26.7	25.6	22.2	17.8	26.3	25.2	21.9	17.5	24.6	23.6	20.5	16.4	24.6	23.6	20.5	16.4																				
ΔT		8.3	8.4	8.7	8.9	8.8	9.0	9.3	9.5	9.3	9.5	9.8	10.1	9.8	9.9	10.2	10.5	10.1	10.3	10.6	11.0	10.4	10.6	11.0	10.4	10.6	11.0	11.3	11.3																				
kW		250	269	284	296	280	301	318	332	318	343	362	377	363	390	412	430	408	439	464	484	451	485	512	534	451	485	512	534																				
Hi PR		106	113	123	131	112	119	130	138	116	124	135	144	122	130	142	151	128	136	149	158	132	141	154	164	132	141	154	164																				
Lo PR		105	108	115	123	103	105	112	120	101	103	110	117	98	100	107	114	93	95	102	109	86	88	94	101	86	88	94	101																				
MBh		0.84	0.79	0.64	0.5	0.87	0.82	0.67	0.5	0.89	0.84	0.68	0.5	0.92	0.86	0.70	0.5	0.96	0.90	0.73	0.5	0.97	0.91	0.74	0.6	0.97	0.91	0.74	0.6																				
S/T		29.1	27.9	24.3	19.4	29.5	28.2	24.5	19.6	29.5	28.3	24.6	19.6	29.7	28.5	24.7	19.8	29.3	28.1	24.4	19.5	27.3	26.2	22.8	18.2	27.3	26.2	22.8	18.2																				
ΔT		8.1	8.3	8.5	8.7	8.6	8.8	9.1	9.3	9.1	9.3	9.6	9.8	9.5	9.7	10.0	10.3	9.9	10.1	10.4	10.7	10.2	10.4	10.7	11.0	10.2	10.4	10.7	11.0																				
kW		242	261	275	287	272	292	309	322	309	332	351	366	352	379	400	417	396	426	450	469	437	471	497	518	437	471	497	518																				
Hi PR		103	109	119	127	108	115	126	134	113	120	131	139	118	126	137	146	124	132	144	153	128	136	149	159	128	136	149	159																				
Lo PR		120	122	128	136	117	119	125	133	114	116	122	130	111	114	119	127	106	108	113	120	98	100	105	112	98	100	105	112																				
MBh		0.96	0.92	0.83	0.7	0.99	0.96	0.86	0.7	1.00	0.98	0.89	0.7	1.00	1.00	0.92	0.7	1.00	1.00	0.95	0.8	1.00	1.00	0.96	0.8	1.00	1.00	0.96	0.8																				
S/T		26.8	26.3	24.9	21.6	27.1	26.7	25.2	21.8	26.7	26.7	25.2	21.8	26.0	26.5	25.4	22.0	24.7	25.2	25.1	21.7	22.9	23.3	23.4	20.3	22.9	23.3	23.4	20.3																				
ΔT		8.4	8.6	8.8	9.0	9.0	9.1	9.4	9.7	9.5	9.6	9.9	10.2	9.9	10.1	10.4	10.7	10.3	10.5	10.8	11.1	10.6	10.8	11.1	11.5	10.6	10.8	11.1	11.5																				
kW		255	274	289	302	286	307	325	339	325	350	369	385	370	398	420	439	416	448	473	493	460	495	523	545	460	495	523	545																				
Hi PR		108	115	125	133	114	121	132	141	118	126	138	147	124	132	145	154	130	139	151	161	135	144	157	167	135	144	157	167																				
Lo PR		116	118	124	132	114	116	121	129	111	113	118	126	108	110	115	123	103	105	110	117	95	97	102	108	95	97	102	108																				
MBh		0.91	0.88	0.80	0.65	0.95	0.91	0.82	0.67	0.97	0.94	0.85	0.69	1.00	0.97	0.87	0.71	1.00	1.00	0.91	0.74	1.00	1.00	0.91	0.7	1.00	1.00	0.91	0.7																				
S/T		27.9	27.4	25.9	22.5	28.2	27.8	26.3	22.7	28.3	27.8	26.3	22.8	28.4	28.0	26.5	22.9	27.0	27.5	26.1	22.6	25.0	25.5	24.4	21.1	25.0	25.5	24.4	21.1																				
ΔT		8.3	8.5	8.7	9.0	8.9	9.1	9.3	9.6	9.4	9.6	9.8	10.1	9.8	10.0	10.3	10.6	10.2	10.4	10.7	11.0	10.5	10.7	11.0	11.4	10.5	10.7	11.0	11.4																				
kW		252	271	286	299	283	304	321	335	322	346	366	381	366	394	416	434	412	444	468	489	455	490	517	540	455	490	517	540																				
Hi PR		107	114	124	132	113	120	131	140	117	125	136	145	123	131	143	152	129	137	150	160	134	142	155	165	134	142	155	165																				
Lo PR		107	109	115	122	105	107	112	119	102	104	109	116	100	102	107	114	95	97	101	108	88	90	94	100	88	90	94	100																				
MBh		0.88	0.85	0.77	0.6	0.91	0.88	0.80	0.6	0.94	0.90	0.82	0.7	0.97	0.93	0.84	0.7	1.00	0.97	0.87	0.7	1.00	0.98	0.88	0.7	1.00	0.98	0.88	0.7																				
S/T		31.0	30.5	28.9	25.0	31.4	30.9	29.2	25.3	31.5	30.9	29.2	25.3	31.7	31.2	29.4	25.5	31.1	30.7	29.0	25.1	28.8	28.7	27.1	23.5	28.8	28.7	27.1	23.5																				
ΔT		8.2	8.3	8.5	8.8	8.7	8.9	9.1	9.4	9.2	9.4	9.6	9.9	9.6	9.8	10.1	10.4	10.0	10.2	10.5	10.8	10.3	10.5	10.8	11.1	10.3	10.5	10.8	11.1																				
kW		244	263	278	290	274	295	312	325	312	336	355	370	355	382	404	421	400	430	454	474	442	475	502	524	442	475	502	524																				
Hi PR		104	110	120	128	109	116	127	135	114	121	132	141	120	127	139	148	125	133	145	155	130	138	150	160	130	138	150	160																				
Lo PR		104	110	120	128	109	116	127	135	114	121	132	141	120	127	139	148	125	133	145	155	130	138	150	160	130	138	150	160																				

IDB		OUTDOOR AMBIENT TEMPERATURE																																															
		65								75								85								95								105								115							
		59	63	67	71	59	63	67	71	59	63	67	71	59	63	67	71	59	63	67	71	59	63	67	71	59	63	67	71	59	63	67	71																
AIRFLOW		118	120	128	137	115	117	125	134	112	115	122	131	109	112	119	128	104	106	114	121	104	106	114	121	96	98	105	112																				
MBh		0.91	0.86	0.70	0.5	0.95	0.89	0.72	0.5	1.00	0.91	0.74	0.6	1.00	0.94	0.77	0.6	1.00	1.00	0.79	0.6	1.00	1.00	0.79	0.6	1.00	1.00	0.80	0.6																				
S/T		25.1	24.1	20.9	16.7	25.4	24.4	21.2	16.9	26.2	24.4	21.2	16.9	25.6	24.6	21.4	17.1	24.3	24.8	21.1	16.8	22.5	23.0	21.1	16.8	22.5	23.0	19.7	15.7																				
ΔT		8.3	8.5	8.7	9.0	8.9	9.1	9.3	9.6	9.4	9.6	9.8	10.1	9.8	10.0	10.3	10.6	10.2	10.4	10.7	11.0	10.5	10.7	11.0	11.4	10.5	10.7	11.0	11.4																				
kW		252	271	286	299	283	304	321	335	322	346	366	381	366	394	416	434	412	444	468	489	455	490	517	540	455	490	517	540																				
Hi PR		107	114	124	132	113	120	131	140	117	125	136	145	123	131	143	152	129	137	150	160	134	142	155	165	134	142	155	165																				
Lo PR		114	117	125	133	112	114	122	130	109	111	119	127	106	109	116	124	101	103	110	118	94	96	102	109	94	96	102	109																				
MBh		0.87	0.82	0.67	0.50	0.90	0.85	0.69	0.52	0.93	0.87	0.71	0.53	0.96	0.90	0.73	0.55	0.99	0.93	0.76	0.57	1.00	0.94	0.76	0.6	1.00	0.94	0.76	0.6																				
S/T		26.2	25.1	21.8	17.4	26.5	25.4	22.1	17.6	26.5	25.4	22.1																																					

# AIRFLOW DATA — 7½ TONS

## STANDARD BELT DRIVE — HORIZONTAL

ESP (" W.C.)	TURNS OPEN																	
	0			1			2			3			4			5		
	CFM	RPM	BHP	CFM	RPM	BHP	CFM	RPM	BHP	CFM	RPM	BHP	CFM	RPM	BHP	CFM	RPM	BHP
0.1	---	---	---	---	---	---	---	---	---	---	---	---	3434	745	0.96	3264	701	0.79
0.3	---	---	---	---	---	---	---	---	---	3424	800	1.05	3165	747	0.90	2921	704	0.79
0.5	---	---	---	---	---	---	3496	850	1.14	3102	803	0.92	2785	749	0.83	2545	706	0.66
0.7	---	---	---	3397	900	1.32	3158	851	1.06	2735	805	0.82	2345	753	0.73	---	---	---
0.9	3440	946	1.44	3079	901	1.16	2778	855	1.01	---	---	---	---	---	---	---	---	---
1.1	3122	948	1.27	2745	906	1.07	2382	857	0.86	---	---	---	---	---	---	---	---	---
1.3	---	---	---	---	---	---	---	---	---	---	---	---	---	---	---	---	---	---

## HIGH-STATIC BELT DRIVE — HORIZONTAL

ESP (" W.C.)	TURNS OPEN																	
	0			1			2			3			4			5		
	CFM	RPM	BHP	CFM	RPM	BHP	CFM	RPM	BHP	CFM	RPM	BHP	CFM	RPM	BHP	CFM	RPM	BHP
0.7	---	---	---	---	---	---	---	---	---	---	---	---	3446	902	1.26	3098	849	1.11
0.9	---	---	---	---	---	---	---	---	---	---	---	---	3110	905	1.17	2745	851	0.96
1.1	---	---	---	---	---	---	---	---	---	3200	963	1.37	2769	909	1.09	---	---	---
1.3	---	---	---	---	---	---	3256	1017	1.66	2889	964	1.31	---	---	---	---	---	---
1.5	---	---	---	3443	1087	1.91	2923	1022	1.47	---	---	---	---	---	---	---	---	---
1.7	3586	1129	2.18	3038	1081	1.62	2509	1029	1.28	---	---	---	---	---	---	---	---	---
1.9	3221	1137	1.87	2588	1073	1.50	---	---	---	---	---	---	---	---	---	---	---	---
2.1	2827	1144	1.71	---	---	---	---	---	---	---	---	---	---	---	---	---	---	---

## STANDARD BELT DRIVE — DOWN SHOT

ESP (" W.C.)	TURNS OPEN																	
	0			1			2			3			4			5		
	CFM	RPM	BHP	CFM	RPM	BHP	CFM	RPM	BHP	CFM	RPM	BHP	CFM	RPM	BHP	CFM	RPM	BHP
0.1	---	---	---	---	---	---	---	---	---	---	---	---	3481	747	0.95	3240	698	0.78
0.3	---	---	---	---	---	---	---	---	---	3498	795	1.09	3197	748	0.88	2889	702	0.71
0.5	---	---	---	---	---	---	3414	844	1.22	3091	796	0.91	2837	749	0.79	2491	701	0.59
0.7	3720	935	1.58	3414	889	1.35	3060	845	1.14	2715	800	0.85	---	---	---	---	---	---
0.9	3351	940	1.45	3066	894	1.18	2688	847	0.99	---	---	---	---	---	---	---	---	---
1.1	3114	942	1.34	2677	896	1.05	---	---	---	---	---	---	---	---	---	---	---	---
1.3	---	---	---	---	---	---	---	---	---	---	---	---	---	---	---	---	---	---

## HIGH-STATIC BELT DRIVE — DOWN SHOT

ESP (" W.C.)	TURNS OPEN																	
	0			1			2			3			4			5		
	CFM	RPM	BHP	CFM	RPM	BHP	CFM	RPM	BHP	CFM	RPM	BHP	CFM	RPM	BHP	CFM	RPM	BHP
0.7	---	---	---	---	---	---	---	---	---	---	---	---	3428	900	1.25	3045	846	1.06
0.9	---	---	---	---	---	---	---	---	---	3521	958	1.49	3084	905	1.14	2679	850	0.95
1.1	---	---	---	---	---	---	---	---	---	3181	964	1.31	2756	908	1.06	---	---	---
1.3	---	---	---	---	---	---	3358	1020	1.59	2885	967	1.22	---	---	---	---	---	---
1.5	---	---	---	3470	1075	1.81	2950	1024	1.40	2452	972	1.13	---	---	---	---	---	---
1.7	3465	1130	2.11	3065	1080	1.67	2492	1030	1.25	---	---	---	---	---	---	---	---	---
1.9	3147	1136	1.89	2706	1087	1.53	---	---	---	---	---	---	---	---	---	---	---	---
2.1	2719	1142	1.70	---	---	---	---	---	---	---	---	---	---	---	---	---	---	---

**NOTES**

- Assume dry coil with filter in place; CFM correction for wet coil = 3%
- Any adjustment made to the blower should not cause the motor to draw more than the motor rated RLA. Applications that exceed the above could require a larger motor. Minimum rated SCFM is 350 per ton.

# AIRFLOW DATA — 8½ TONS

## STANDARD BELT DRIVE — HORIZONTAL

ESP (" W.C.)	TURNS OPEN																	
	0			1			2			3			4			5		
	CFM	RPM	BHP	CFM	RPM	BHP	CFM	RPM	BHP	CFM	RPM	BHP	CFM	RPM	BHP	CFM	RPM	BHP
0.1	---	---	---	---	---	---	---	---	---	4190	792	1.29	3862	743	1.02	3546	695	0.86
0.3	---	---	---	---	---	---	4141	839	1.41	3850	794	1.19	3540	747	1.00	3152	699	0.81
0.5	---	---	---	4057	883	1.46	3759	843	1.27	3471	798	1.12	3175	747	0.91	2692	700	0.67
0.7	4120	934	1.61	3775	894	1.41	3415	846	1.14	3097	800	0.99	2652	752	0.70	---	---	---
0.9	3780	938	1.49	3338	894	1.27	3030	850	1.04	2497	805	0.82	---	---	---	---	---	---
1.1	3311	942	1.36	2904	899	1.06	2375	855	0.87	---	---	---	---	---	---	---	---	---
1.3	---	---	---	---	---	---	---	---	---	---	---	---	---	---	---	---	---	---

## HIGH-STATIC BELT DRIVE — HORIZONTAL

ESP (" W.C.)	TURNS OPEN																	
	0			1			2			3			4			5		
	CFM	RPM	BHP	CFM	RPM	BHP	CFM	RPM	BHP	CFM	RPM	BHP	CFM	RPM	BHP	CFM	RPM	BHP
0.7	---	---	---	---	---	---	---	---	---	4157	938	1.73	3462	854	1.24	3338	832	1.15
0.9	---	---	---	---	---	---	4160	969	1.89	3865	941	1.60	3237	873	1.17	2855	838	0.96
1.1	---	---	---	---	---	---	3882	985	1.79	3480	949	1.47	2849	886	1.09	---	---	---
1.3	---	---	---	4082	1053	2.15	3495	999	1.55	3097	957	1.32	---	---	---	---	---	---
1.5	4188	1108	2.38	3760	1061	1.87	3108	1010	1.41	---	---	---	---	---	---	---	---	---
1.7	3884	1117	2.15	3371	1070	1.66	---	---	---	---	---	---	---	---	---	---	---	---
1.9	3499	1126	1.98	---	---	---	---	---	---	---	---	---	---	---	---	---	---	---

## STANDARD BELT DRIVE — DOWN SHOT

ESP (" W.C.)	TURNS OPEN																	
	0			1			2			3			4			5		
	CFM	RPM	BHP	CFM	RPM	BHP	CFM	RPM	BHP	CFM	RPM	BHP	CFM	RPM	BHP	CFM	RPM	BHP
0.1	---	---	---	---	---	---	---	---	---	---	---	---	---	---	---	3818	698	1.02
0.3	---	---	---	---	---	---	---	---	---	---	---	---	---	---	---	3450	701	0.84
0.5	---	---	---	---	---	---	---	---	---	3801	795	1.20	3563	773	1.04	3012	704	0.81
0.7	---	---	---	---	---	---	3760	844	1.27	3355	799	1.05	3099	774	0.98	---	---	---
0.9	---	---	---	3724	891	1.44	3350	846	1.17	2707	801	0.90	2497	778	0.78	---	---	---
1.1	3795	947	1.50	3205	897	1.25	2673	851	0.98	---	---	---	---	---	---	---	---	---
1.3	---	---	---	---	---	---	---	---	---	---	---	---	---	---	---	---	---	---

## HIGH-STATIC BELT DRIVE — DOWN SHOT

ESP (" W.C.)	TURNS OPEN																	
	0			1			2			3			4			5		
	CFM	RPM	BHP	CFM	RPM	BHP	CFM	RPM	BHP	CFM	RPM	BHP	CFM	RPM	BHP	CFM	RPM	BHP
0.7	---	---	---	---	---	---	---	---	---	---	---	---	---	---	---	3679	830	1.20
0.9	---	---	---	---	---	---	---	---	---	---	---	---	3784	894	1.35	3265	836	1.12
1.1	---	---	---	---	---	---	---	---	---	3833	952	1.59	3247	900	1.23	2742	843	0.94
1.3	---	---	---	---	---	---	3943	1007	1.88	3361	957	1.45	2867	905	1.08	---	---	---
1.5	---	---	---	---	---	---	3522	1012	1.73	2928	962	1.33	---	---	---	---	---	---
1.7	---	---	---	3638	1469	1.99	3018	1020	1.47	---	---	---	---	---	---	---	---	---
1.9	3725	1118	2.24	3018	1078	1.66	---	---	---	---	---	---	---	---	---	---	---	---
2.1	3326	1126	2.04	---	---	---	---	---	---	---	---	---	---	---	---	---	---	---

**NOTES**

- Assume dry coil with filter in place; CFM correction for wet coil = 3%
- Any adjustment made to the blower should not cause the motor to draw more than the motor rated RLA. Applications that exceed the above could require a larger motor. Minimum rated SCFM is 350 per ton.

# AIRFLOW DATA — 10 TONS

## STANDARD BELT DRIVE — HORIZONTAL

ESP (" W.C.)	TURNS OPEN																	
	0			1			2			3			4			5		
	CFM	RPM	BHP	CFM	RPM	BHP	CFM	RPM	BHP	CFM	RPM	BHP	CFM	RPM	BHP	CFM	RPM	BHP
0.1	---	---	---	---	---	---	---	---	---	4190	792	1.29	3862	743	1.02	3546	695	0.86
0.3	---	---	---	---	---	---	4141	839	1.41	3850	794	1.19	3540	747	1.00	3152	699	0.81
0.5	---	---	---	4057	883	1.46	3759	843	1.27	3471	798	1.12	3175	747	0.91	2692	700	0.67
0.7	4120	934	1.61	3775	894	1.41	3415	846	1.14	3097	800	0.99	2652	752	0.70	---	---	---
0.9	3780	938	1.49	3338	894	1.27	3030	850	1.04	2497	805	0.82	---	---	---	---	---	---
1.1	3311	942	1.36	2904	899	1.06	2375	855	0.87	---	---	---	---	---	---	---	---	---
1.3	---	---	---	---	---	---	---	---	---	---	---	---	---	---	---	---	---	---

## HIGH-STATIC BELT DRIVE — HORIZONTAL

ESP (" W.C.)	TURNS OPEN																	
	0			1			2			3			4			5		
	CFM	RPM	BHP	CFM	RPM	BHP	CFM	RPM	BHP	CFM	RPM	BHP	CFM	RPM	BHP	CFM	RPM	BHP
0.7	---	---	---	---	---	---	---	---	---	4157	938	1.73	3462	854	1.24	3338	832	1.15
0.9	---	---	---	---	---	---	4160	969	1.89	3865	941	1.60	3237	873	1.17	2855	838	0.96
1.1	---	---	---	---	---	---	3882	985	1.79	3480	949	1.47	2849	886	1.09	---	---	---
1.3	---	---	---	4082	1053	2.15	3495	999	1.55	3097	957	1.32	---	---	---	---	---	---
1.5	4188	1108	2.38	3760	1061	1.87	3108	1010	1.41	---	---	---	---	---	---	---	---	---
1.7	3884	1117	2.15	3371	1070	1.66	---	---	---	---	---	---	---	---	---	---	---	---
1.9	3499	1126	1.98	---	---	---	---	---	---	---	---	---	---	---	---	---	---	---

## STANDARD BELT DRIVE — DOWN SHOT

ESP (" W.C.)	TURNS OPEN																	
	0			1			2			3			4			5		
	CFM	RPM	BHP	CFM	RPM	BHP	CFM	RPM	BHP	CFM	RPM	BHP	CFM	RPM	BHP	CFM	RPM	BHP
0.1	---	---	---	---	---	---	---	---	---	---	---	---	---	---	---	3818	698	1.02
0.3	---	---	---	---	---	---	---	---	---	---	---	---	---	---	---	3450	701	0.84
0.5	---	---	---	---	---	---	---	---	---	3801	795	1.20	3563	773	1.04	3012	704	0.81
0.7	---	---	---	---	---	---	3760	844	1.27	3355	799	1.05	3099	774	0.98	---	---	---
0.9	---	---	---	3724	891	1.44	3350	846	1.17	2707	801	0.90	2497	778	0.78	---	---	---
1.1	3795	947	1.50	3205	897	1.25	2673	851	0.98	---	---	---	---	---	---	---	---	---
1.3	---	---	---	---	---	---	---	---	---	---	---	---	---	---	---	---	---	---

## HIGH-STATIC BELT DRIVE — DOWN SHOT

ESP (" W.C.)	TURNS OPEN																	
	0			1			2			3			4			5		
	CFM	RPM	BHP	CFM	RPM	BHP	CFM	RPM	BHP	CFM	RPM	BHP	CFM	RPM	BHP	CFM	RPM	BHP
0.7	---	---	---	---	---	---	---	---	---	---	---	---	---	---	---	3679	830	1.20
0.9	---	---	---	---	---	---	---	---	---	---	---	---	3784	894	1.35	3265	836	1.12
1.1	---	---	---	---	---	---	---	---	---	3833	952	1.59	3247	900	1.23	2742	843	0.94
1.3	---	---	---	---	---	---	3943	1007	1.88	3361	957	1.45	2867	905	1.08	---	---	---
1.5	---	---	---	---	---	---	3522	1012	1.73	2928	962	1.33	---	---	---	---	---	---
1.7	---	---	---	3638	1469	1.99	3018	1020	1.47	---	---	---	---	---	---	---	---	---
1.9	3725	1118	2.24	3018	1078	1.66	---	---	---	---	---	---	---	---	---	---	---	---
2.1	3326	1126	2.04	---	---	---	---	---	---	---	---	---	---	---	---	---	---	---

**NOTES**

- Assume dry coil with filter in place; CFM correction for wet coil = 3%
- Any adjustment made to the blower should not cause the motor to draw more than the motor rated RLA. Applications that exceed the above could require a larger motor. Minimum rated SCFM is 350 per ton.

DIMENSIONS

MODEL TONNAGE	"A"	"B"
7.5 TON COMMERCIAL GAS, HT PUMP, AIR CONDITIONER	53.339	20.055
8.5 TON COMMERCIAL GAS, HT PUMP, AIR CONDITIONER	53.339	20.055
10 TON COMMERCIAL GAS, HT PUMP, AIR CONDITIONER	53.339	20.055
12.5 TON COMMERCIAL GAS, HT PUMP, AIR CONDITIONER	58.839	18.055

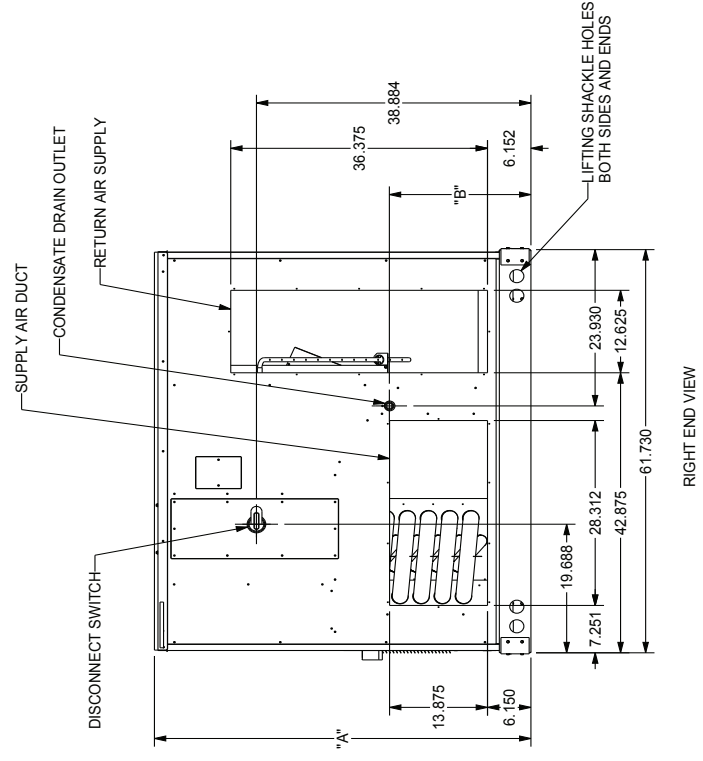
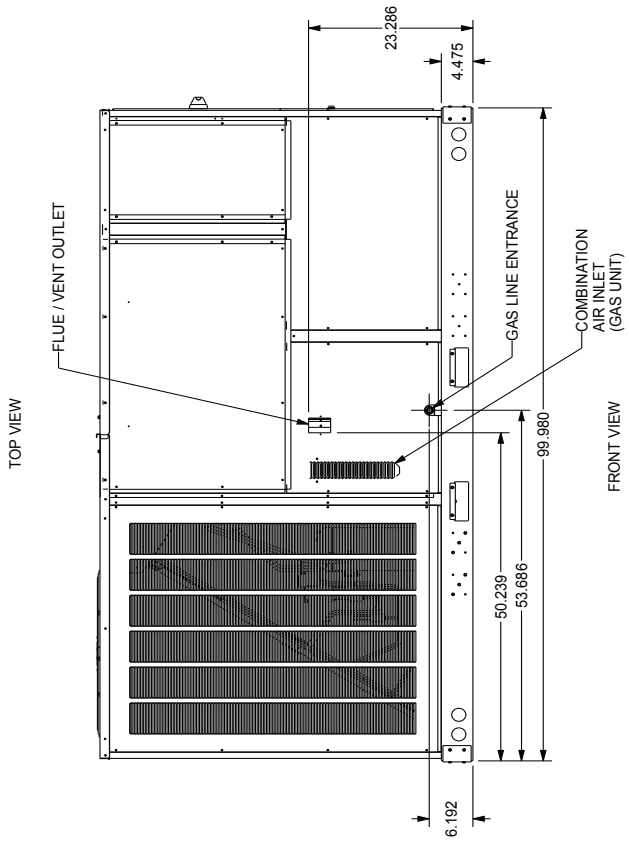
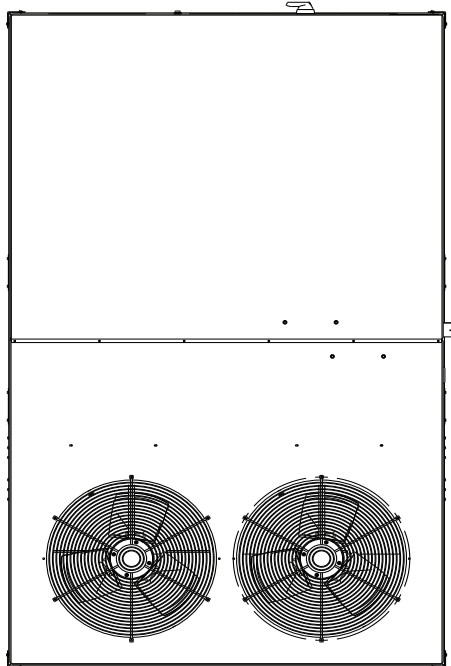

DC\*090-150 \*\*\*

7.5 THRU 12.5 TON COMMERCIAL

ALL DIMENSIONS GIVEN ARE IN INCHES  
ALL DIMENSIONS AND SPECIFICATIONS ARE SUBJECT TO CHANGE WITHOUT NOTICE

## UNIT CLEARANCES

Maintain an adequate clearance around the unit for safety, service, maintenance, and proper unit operation. Leave a total clearance of 75" on the main control panel side of the unit for possible removal of fan shaft, coil, electric heat, and gas furnace. Leave a clearance of 48" on all other sides of the unit for possible compressor removal or service access, and to ensure proper ventilation and condenser airflow. Do not install the unit beneath any obstruction. Install the unit away from all building exhausts to inhibit ingestion of exhaust air into the unit's fresh-air intake.

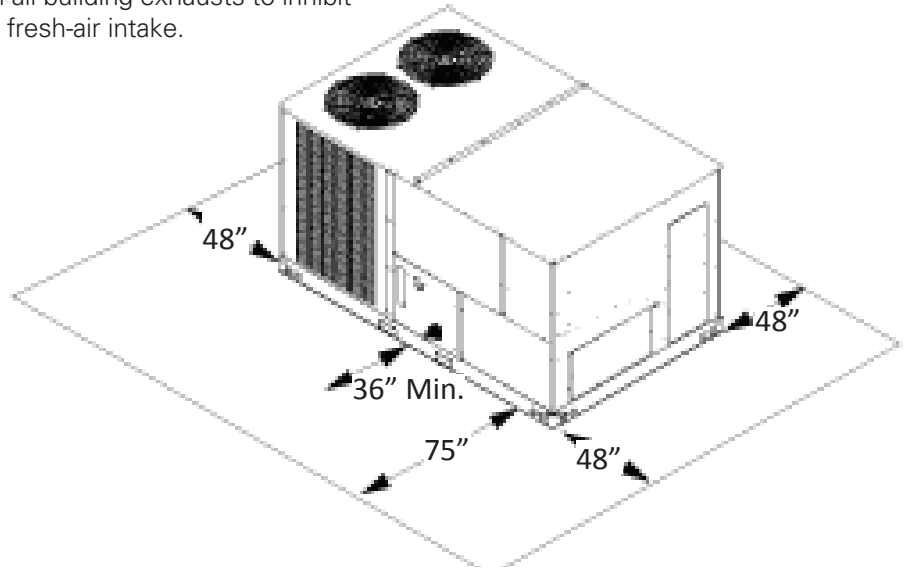

## ELECTRICAL ENTRANCE LOCATIONS

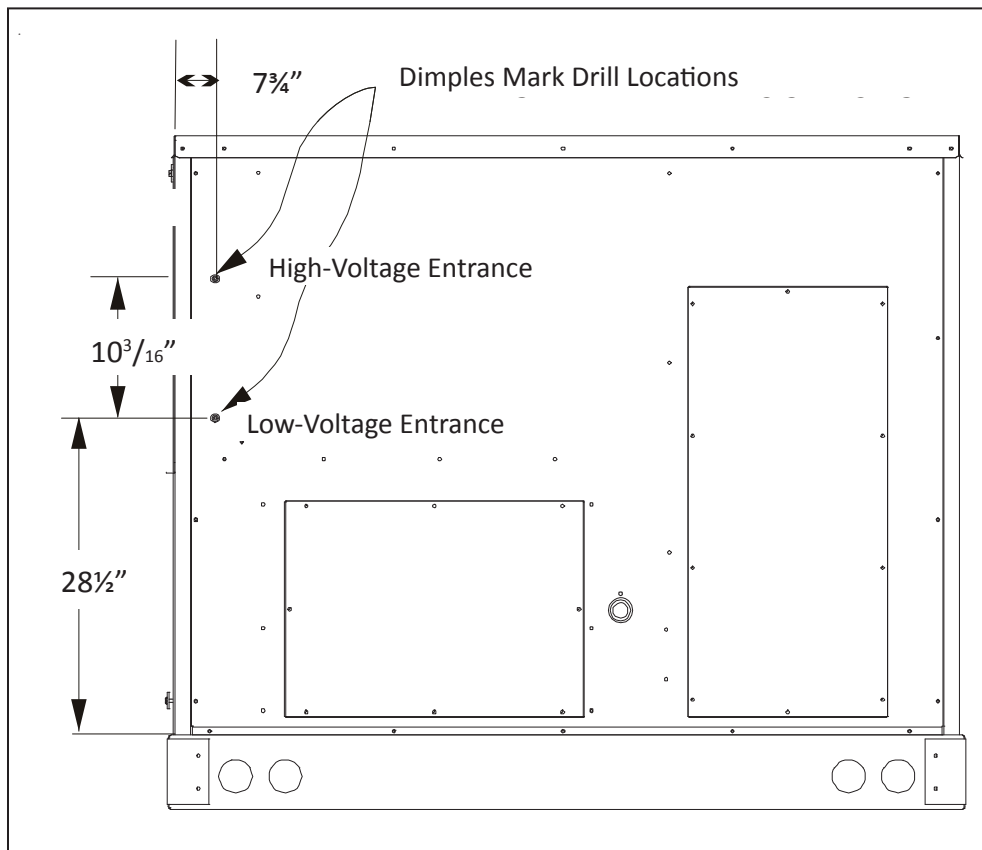

## ROOF CURB INSTALLATION — RIGGING

Provisions for forks have been included in the unit base frame. No other fork locations are approved.

- Unit must be lifted by the four lifting holes located at the base frame corners.
- Lifting cables should be attached to the unit with shackles.
- The distance between the crane hook and the top of the unit must not be less than 60".
- Two spreader bars must span over the unit to prevent damage to the cabinet by the lift cables. Spreader bars must be of sufficient length so that cables do not come in contact with the unit during transport. Remove wood struts mounted beneath unit base frame before setting unit on roof curb. These struts are intended to protect unit base frame from fork lift damage. To remove the struts, extract the sheet metal retainers and pull the struts through the base of the unit. Refer to rigging label on the unit.

**Important:** If using bottom discharge with roof curb, duct-work should be attached to the curb prior to installing the unit. Duct-work dimensions are shown in Roof Curb Installation Instructions Manual.

Refer to the Roof Curb Installation Instructions for proper curb installation. Curbing must be installed in compliance with the National Roofing Contractors Association Manual.

Lower unit carefully onto roof mounting curb. While rigging the unit, the center of gravity will cause the condenser end to be lower than the supply air end.

Bring condenser end of unit into alignment with the curb. With condenser end of the unit resting on curb member and using curb as a fulcrum, lower opposite end of the unit until entire unit is seated on the curb. When a rectangular cantilever curb is used, take care to center the unit. Check for proper alignment and orientation of supply and return openings with duct.

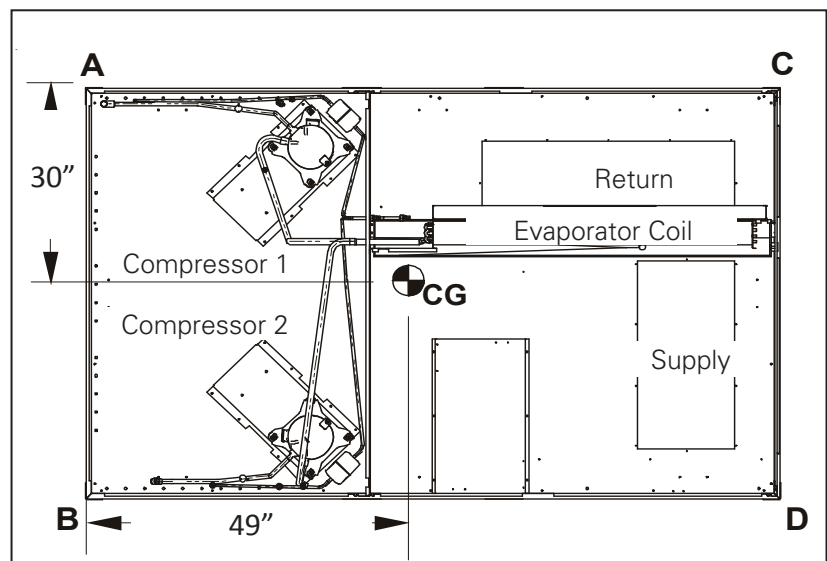
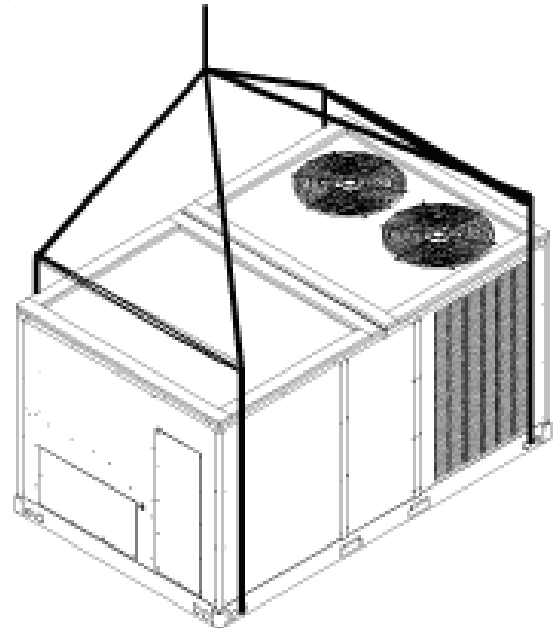

CORNER & CENTER-OF-GRAVITY LOCATIONS

WEIGHT TYPES	7½-TON WEIGHTS (LBS)	8½-TON & 10-TON WEIGHTS (LBS)
Weight A	269	255
Weight B	297	321
Weight C	254	250
Weight D	280	314
Shipping Weight	1175	1215
Operating Weight	1100	1140

To assist in determining rigging requirements, unit weights are shown to the right.

**Note:** These weights are calculated without accessories installed.

## ROOF CURB INSTALLATION (CONT.)

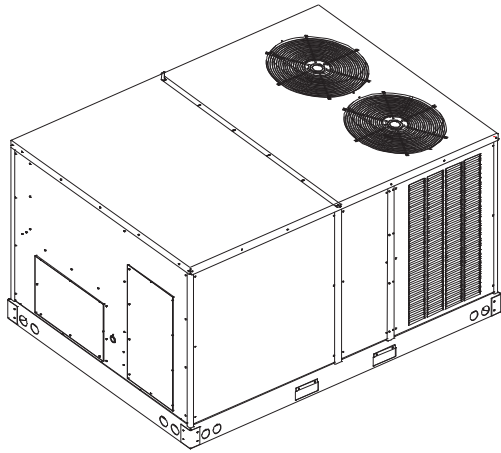

3-D VIEW

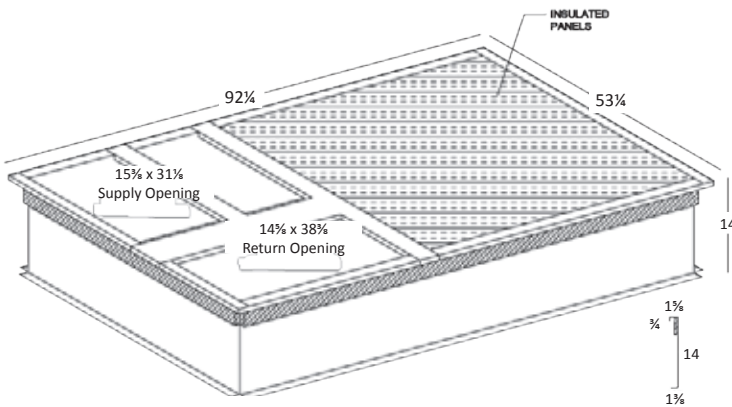

TOP VIEW

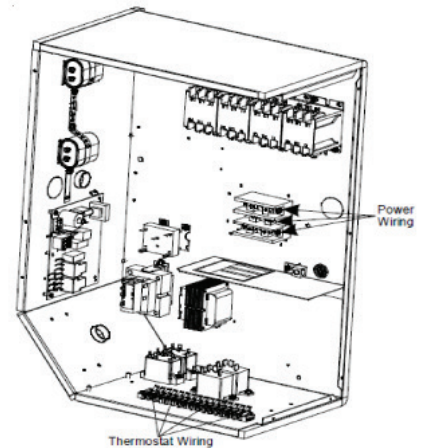
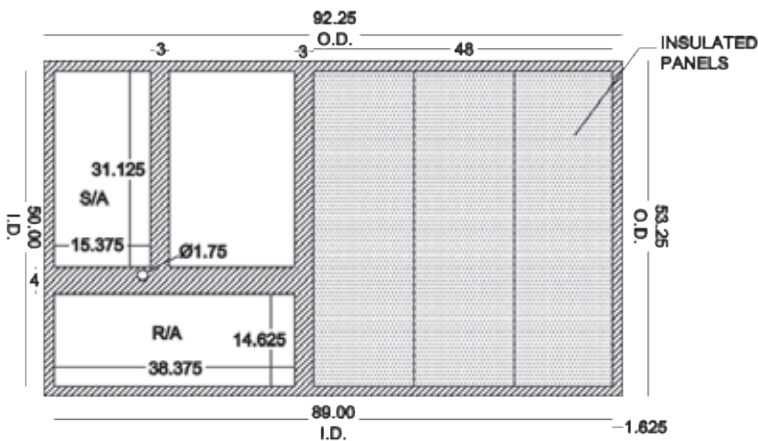

POWER AND LOW-VOLTAGE BLOCK LOCATIONS

Curb installations must comply with local codes and should follow the established guidelines of the National Roofing Contractors Association. Proper unit installation requires that the roof curb be firmly and permanently attached to the roof structure. Check for adequate fastening method prior to setting the unit on the curb.

Full perimeter roof curbs are available from the factory and are shipped unassembled. The installing contractor is responsible for field assembly, squaring, leveling, and mounting on the roof structure. All required hardware necessary for the assembly of the sheet metal curb is included in the curb accessory package.

- Determine sufficient structural support before locating and mounting the curb and package unit.
- Duct-work must be constructed using industry guidelines. The duct-work must be placed into the roof curb before mounting the package unit. Our full perimeter curbs include duct connection frames to be assembled with the curb. Cantilevered-type curbs are not available from the factory.

- Contractor furnishes curb insulation, cant strips, flashing, and general roofing material.
- Support curbs on parallel sides with roof members. To prevent damage to the unit, the roof members cannot penetrate supply and return duct openings.

**Note:** The unit and curb accessories are designed to allow vertical duct installation before unit placement. Duct installation after unit placement is not recommended.

See the manual shipped with the roof curb for assembly and installation instructions.

# DCG 7½ – 10 TONS (400V/ 50 Hz, THREE-PHASE BELT DRIVE)

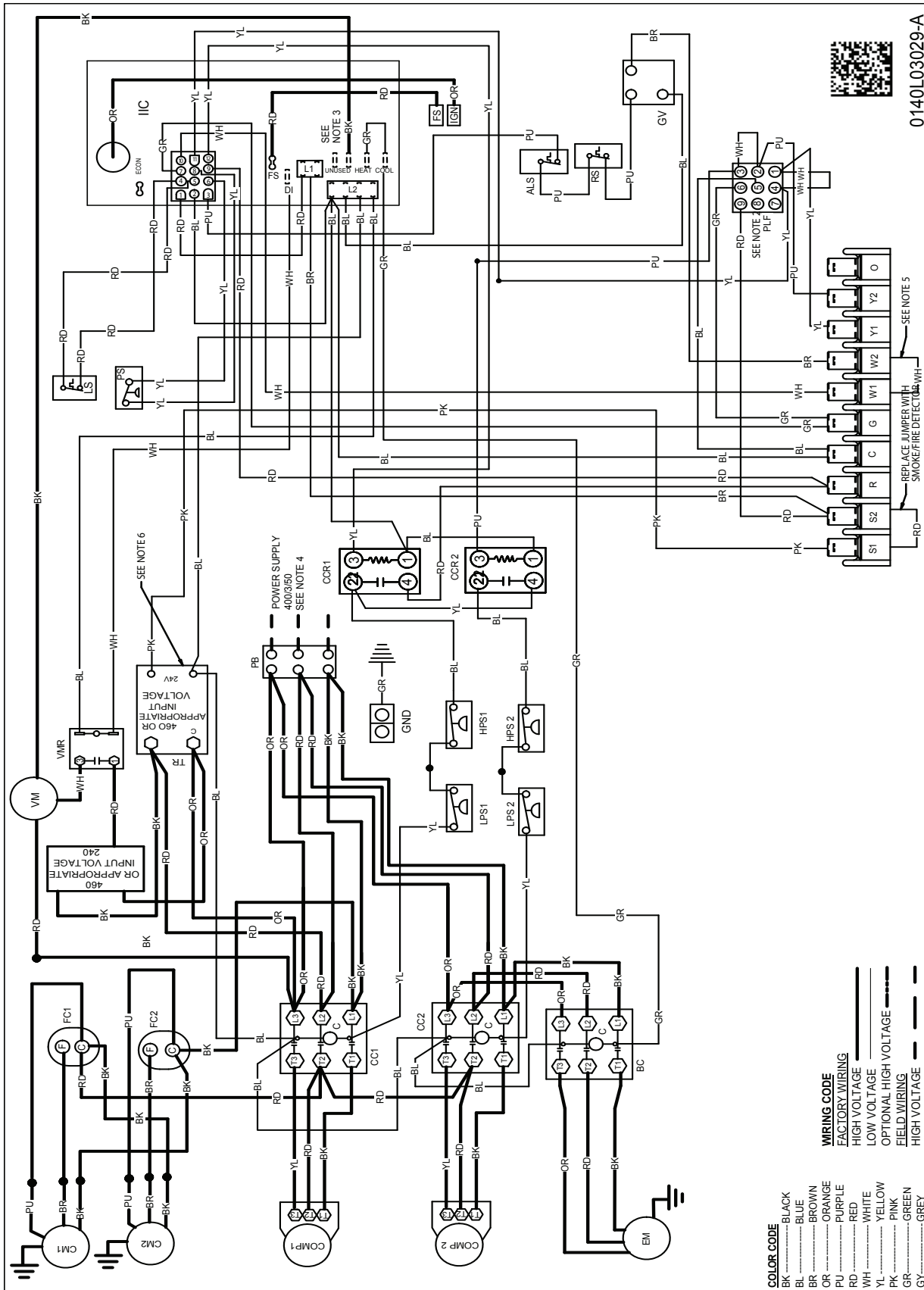

**COLOR CODE**

- BK ..... BLACK
- BL ..... BLUE
- BR ..... BROWN
- OR ..... ORANGE
- PU ..... PURPLE
- RD ..... RED
- WH ..... WHITE
- YL ..... YELLOW
- PK ..... PINK
- GR ..... GREEN
- GY ..... GREY

**WIRING CODE**

- FACTORY WIRING ..... ———
- HIGH VOLTAGE ..... ———
- LOW VOLTAGE ..... ———
- OPTIONAL-HIGH VOLTAGE ..... - - - - -
- FIELD WIRING ..... ———
- HIGH VOLTAGE ..... - - - - -

**WARNING**

**High Voltage:** Disconnect all power before servicing or installing this unit. Multiple power sources may be present. Failure to do so may cause property damage, personal injury, or death.

Wiring is subject to change. Always refer to the wiring diagram or the unit for the most up-to-date wiring.

# DCG 7½ – 10 TONS (400V/ 50 Hz, THREE-PHASE BELT DRIVE)

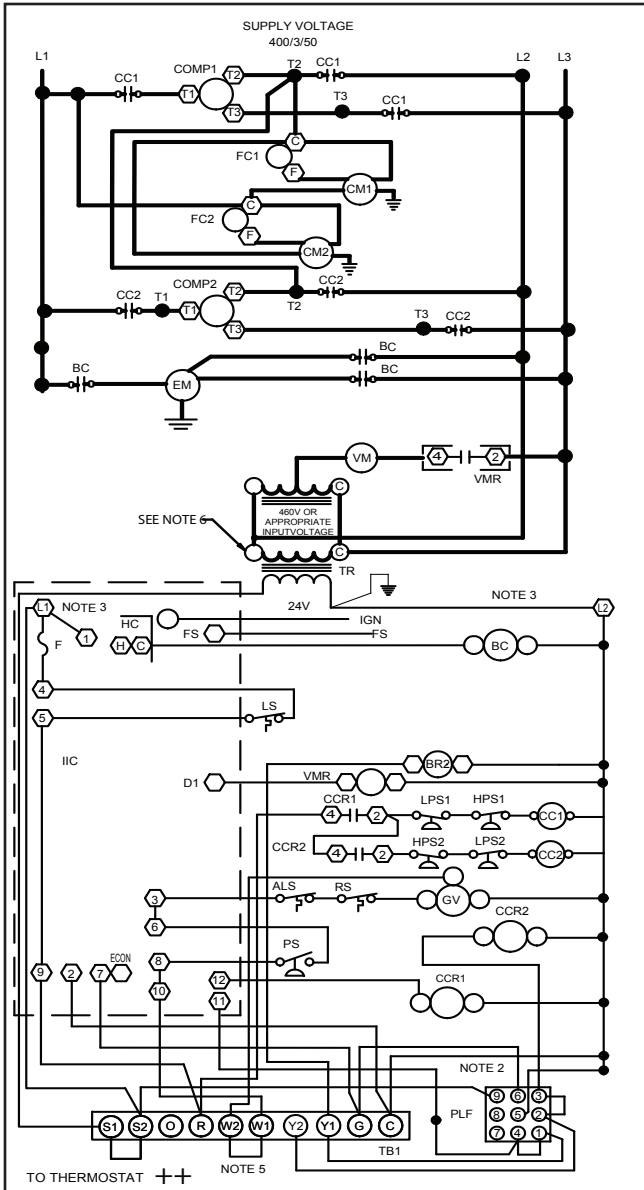

- COMPONENT LEGEND**
- ALS AUXILIARY LIMIT SWITCH
  - BC BLOWER CONTACTOR
  - BR BLOWER RELAY
  - CB CIRCUIT BREAKER
  - CC COMPRESSOR CONTACTOR
  - CCR COMPRESSOR CONTACTOR RELAY
  - CM CONDENSER MOTOR
  - COMP COMPRESSOR
  - EM EVAPORATOR MOTOR
  - F FUSE
  - FC FAN CAPACITOR
  - FS FLAME SENSOR
  - GND EQUIPMENT GROUND
  - GV GAS VALVE
  - HPS HIGH PRESSURE SWITCH
  - IBR INDOOR BLOWER RELAY
  - IIC INTEGRATED IGNITION CONTROL
  - IGN IGNITOR
  - LPS LOW PRESSURE SWITCH
  - LS LIMIT SWITCH
  - PLF FEMALE PLUG/CONNECTOR
  - PS PRESSURE SWITCH
  - RS ROLLOUT SWITCH
  - TB1 TERMINAL BLOCK (24V SIGNAL)
  - TR TRANSFORMER
  - VM VENT MOTOR
  - VMR VENT MOTOR RELAY

- FACTORY WIRING**
- LINE VOLTAGE
  - LOW VOLTAGE
- OPTIONAL HIGH VOLTAGE**
- HIGH VOLTAGE
  - LOW VOLTAGE
- FIELD WIRING**
- HIGH VOLTAGE
  - LOW VOLTAGE
- WIRE CODE**
- BK BLACK
  - BL BLUE
  - BR BROWN
  - GR GREEN
  - OR ORANGE
  - PK PINK
  - PU PURPLE
  - RD RED
  - WH WHITE
  - YL YELLOW
  - YL /PK YELLOW WITH PINK STRIP
  - BL /PK BLUE WITH PINK STRIP

- NOTES**
1. REPLACEMENT WIRE MUST BE THE SAME SIZE AND TYPE OF INSULATION AS ORIGINAL. (USE COPPER CONDUCTOR ONLY).
  2. ACCESSORY ECONOMIZER PLUG ADJACENT TO BLOWER HOUSING IN RETURN AIR COMPARTMENT. REMOVE MALE PLUG AND ATTACH FEMALE PLUG TO THE ECONOMIZER ACCESSORY.
  3. L1 AND L2 ON IIC CONTROL IS 24V INPUT.
  4. USE COPPER CONDUCTORS ONLY. ++ USE NEC CLASS 2 WIRE.
  5. FOR TWO STAGE OPERATION REMOVE W1 TO W2 JUMPER WIRE
  6. MOVE WIRE(S) TO APPROPRIATE INPUT VOLTAGE TERMINAL ON TRANSFORMER.

**High Voltage:** Disconnect all power before servicing or installing this unit. Multiple power sources may be present. Failure to do so may cause property damage, personal injury, or death.

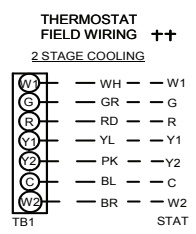

INSTALLER/SERVICEMAN

THE STATUS LIGHT ON THE FURNACE CONTROL MAY BE USED AS A GUIDE TO TROUBLESHOOTING THIS APPLIANCE. STATUS LIGHT CODES ARE AS FOLLOWS:

STATUS LIGHT	EQUIPMENT STATUS	CHECK
ON	NORMAL OPERATION	----
OFF	NO POWER OR INTERNAL CONTROL	CHECK INPUT POWER CHECK FUSE ON CONTROL REPLACE CONTROL
1 BLINK	IGNITION FAILURE	GAS FLOW GAS PRESSURE GAS VALVE
	OPEN ROLLOUT SWITCH	FLAME SENSOR FLAME ROLLOUT BAD SWITCH
2 BLINKS	OPEN AUX. LIMIT SWITCH	AUX. LIMIT OPEN
	PRESSURE SWITCH OPEN	CHECK PRESSURE SWITCH
3 BLINKS	PRESSURE SWITCH CLOSED	CHECK PRESSURE SWITCH
	WITHOUT INDUCER ON	CHECK PRESSURE SWITCH
4 BLINKS	OPEN LIMIT SWITCH	MAIN LIMIT OPEN BAD SWITCH
5 BLINKS	FALSE FLAME SENSED	STICKING GAS VALVE
6 BLINKS	COMPRESSOR OUTPUT DELAY	3 MIN. COMP. ANTI-CYCLE TIMER

SEE UNIT RATING PLATE FOR TYPE AND SIZE OF OVER CURRENT PROTECTION



400V/50Hz 0140L02570-A

Wiring is subject to change. Always refer to the wiring diagram or the unit for the most up-to-date wiring.

## ACCESSORIES

FILED-INSTALLED ITEM #	DESCRIPTION	FITS MODEL SIZES
DDNECNJ90150	Downflow Economizer	7½-10 tons
DHZECNJ90150	Horizontal Economizer	7½-10 tons
	Electric Heat Kits	All Models
HSKT090	High-Static Kit	7½ tons
HSKT120	High-Static Kit	10 tons

## NOTES