

P6 Troubleshooting

P6 Troubleshooting

Zack

Debugging of P6

Diagram of troubleshooting

Current direction confirm

Normal inverter modular confirm

L0/L8/L9 malfunction troubleshooting

L1/L4 malfunction troubleshooting

L2 malfunction troubleshooting

P6 protection will be displayed for 60 seconds then disappear, after that, press the check button 22 times, the digital indicator will display last saved error:

- L0 – Modular protection*
- L1 – Low volt protection of the DC bus bar*
- L2 – High volt protection of the DC bus bar*
- L4 – MEC malfunction*
- L8 – Speed change between two border upon moment more than 15Hz protection*
- L9 – difference between setting speed and actual speed more than 15Hz protection*

•Note: if P6 protection appear 3 times within 30 minutes, the indicator will display H4, system can be recover only after re-electrify.

P6 Troubleshooting

2. Diagram of troubleshooting

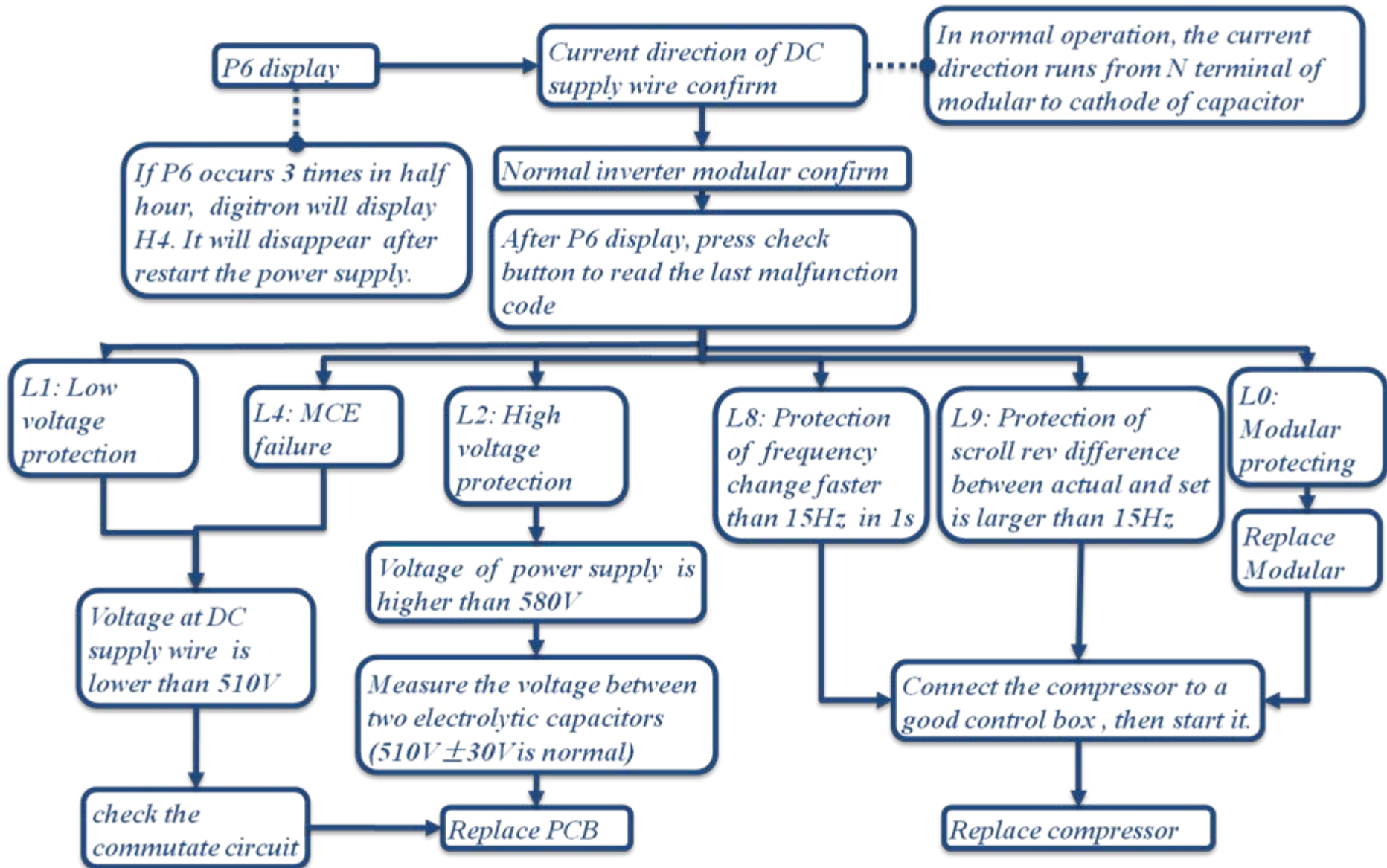

P6 Troubleshooting

3. Outdoor control box

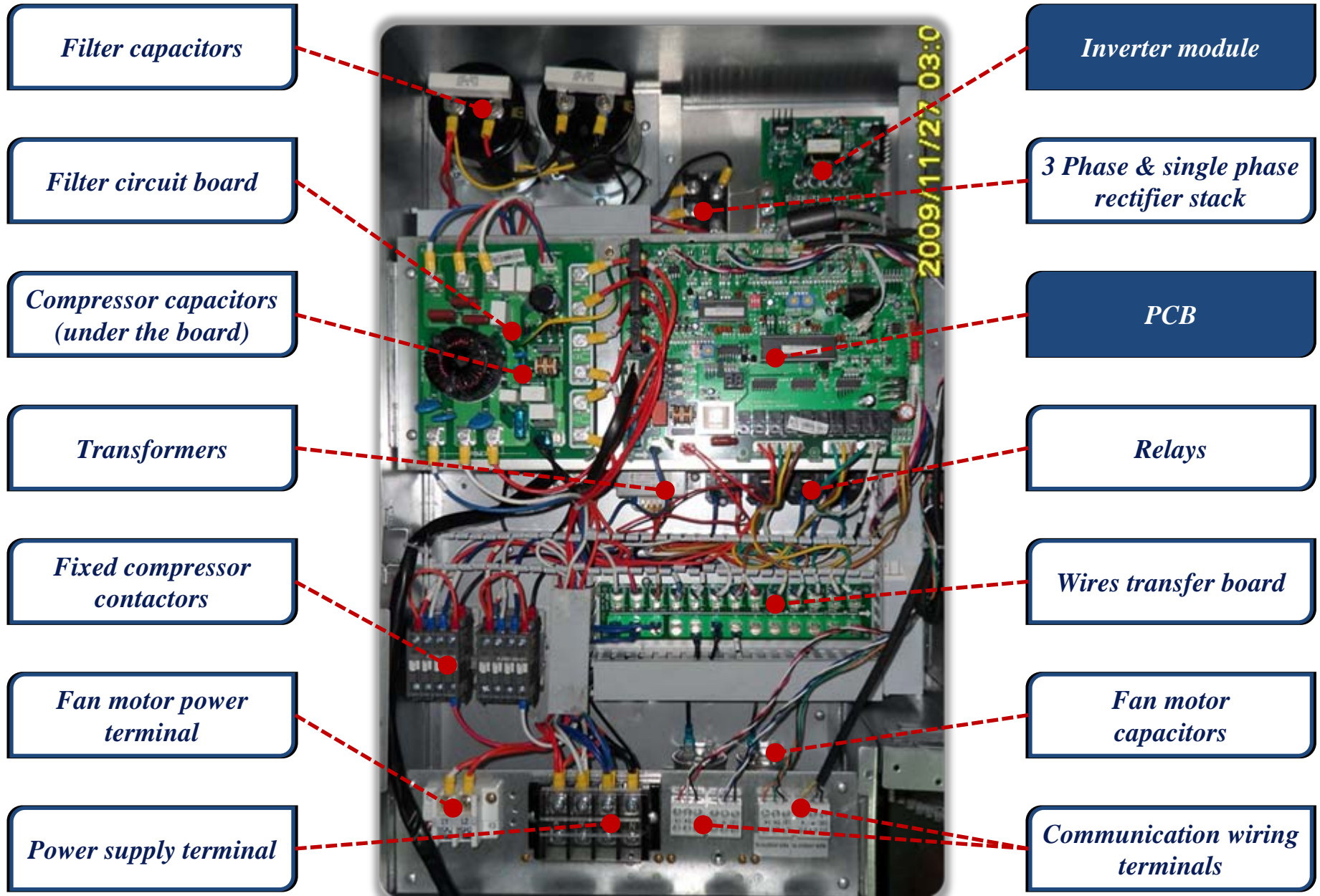

P6 Troubleshooting

4. Outdoor PCB

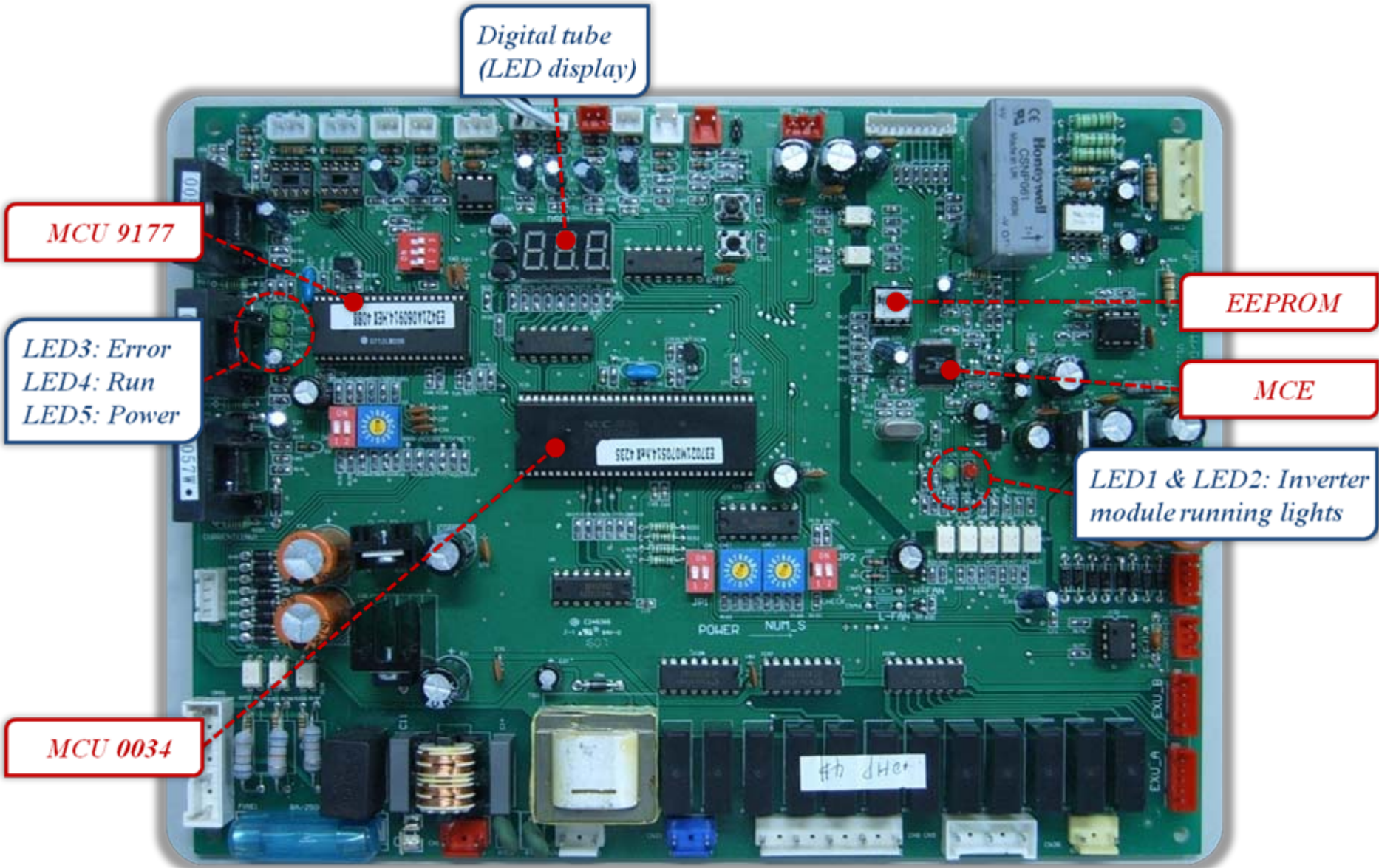



P, N terminal of Rectifier

U, V, W terminal for compressor driving

P6 Troubleshooting

5. Current direction confirm

Normal current direction : 1 → 2 → 3 → 4 → 5 → 6

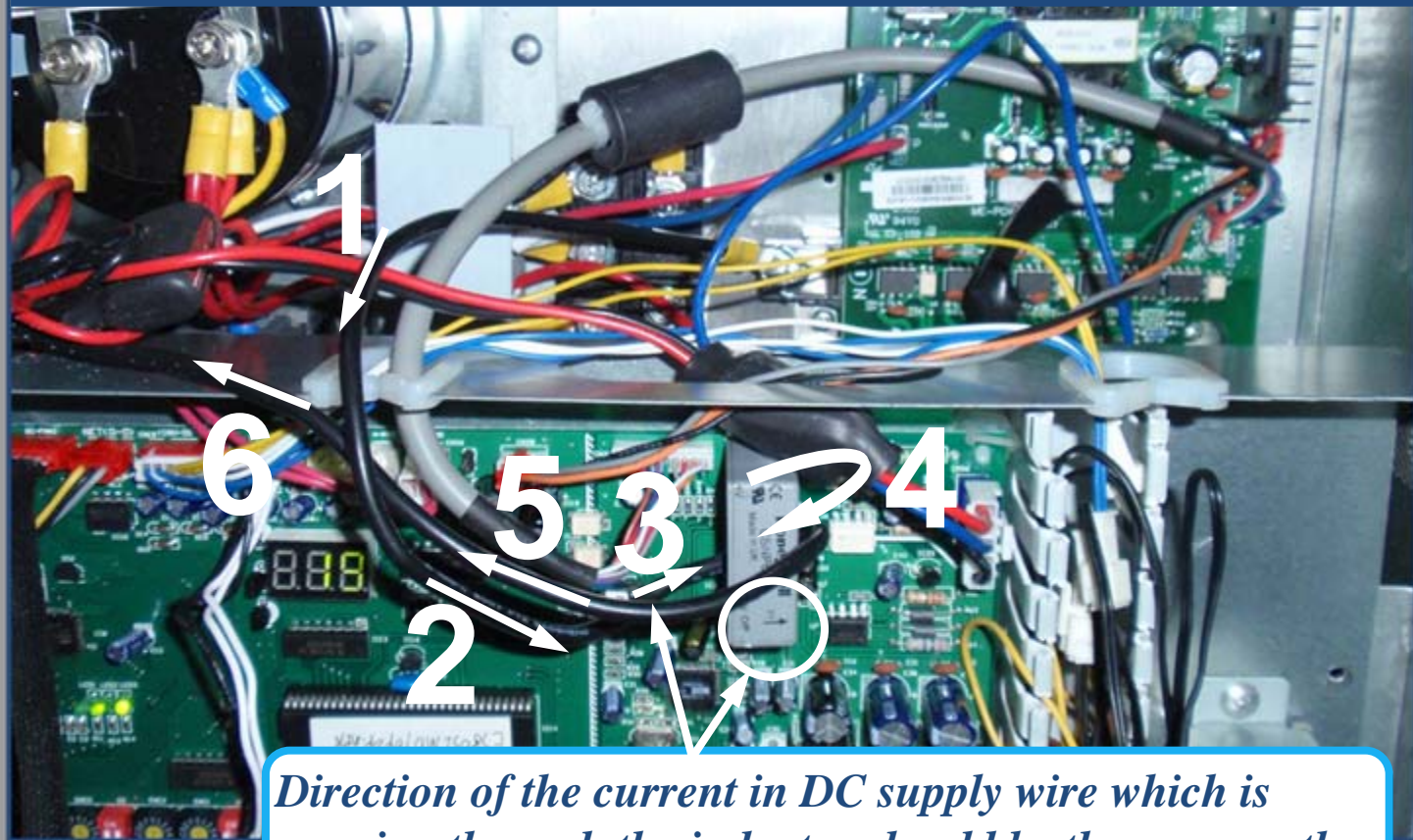

Direction of the current in DC supply wire which is running through the inductor should be the same as the direction of arrow marked on the inductor.

P6 Troubleshooting

6. Normal IPM confirm

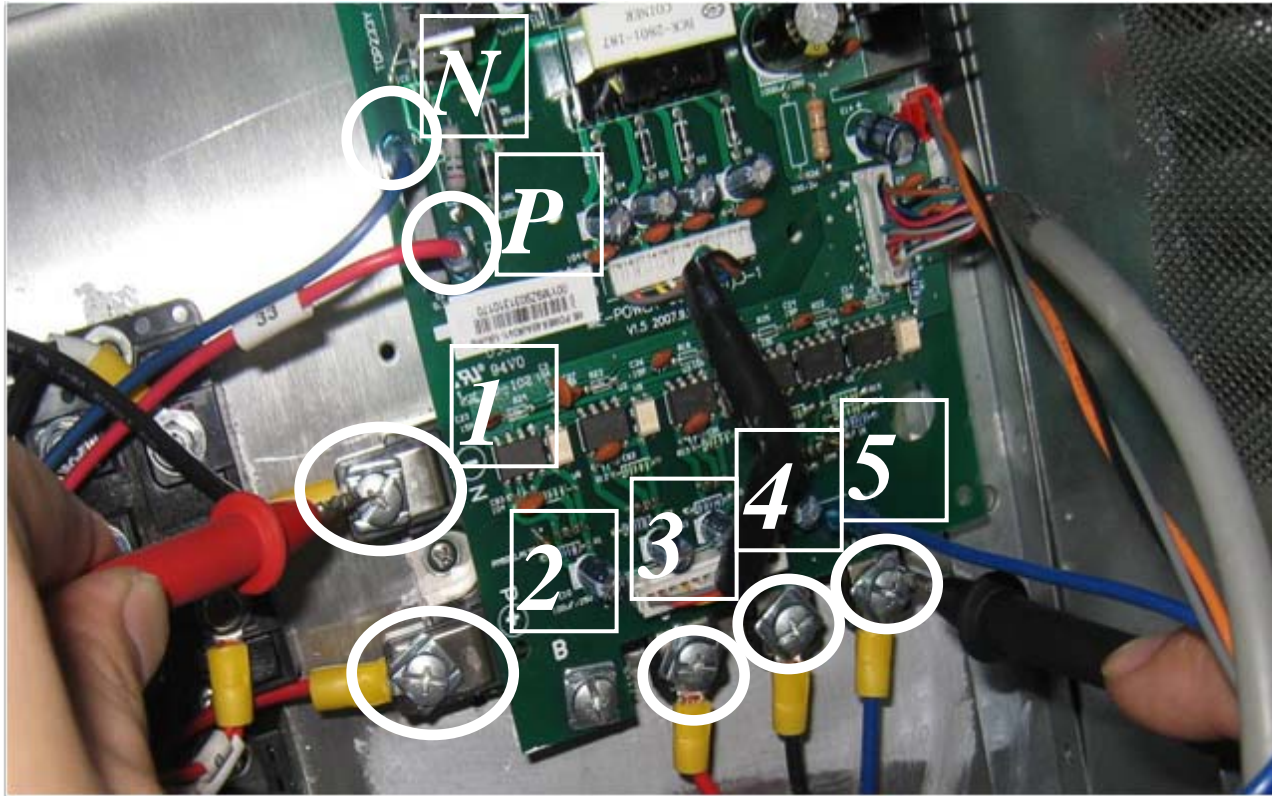

DC voltage between P and N should be about 1.41 times of the local power supply voltage (210V~230V).



DC voltage between 1 and 2 should be 510V to 580V.



Resistance between 1-3, 1-4, 1-5 and 2-3, 2-4, 2-5 should be infinity. If it equal to 0, the modular has been breakdown, needs to be replaced.

First adjust multi-meter to diode position, put the red pen on the 1 point(N terminal), put black pen on the 3 or 4 or 5 point, the value should be approximate 0.378, if the value is 0, the IPM is broken. And then change the red pen to the 2 point(P terminal), the value should be infinity, if the value is 0, the IPM is broken.

P6 Troubleshooting

7. L0/L8/L9 malfunction

Step 1



Replace the modular with correctly wire connected and start the system, if system is still malfunction, then go to step2 to check the compressor.



Step 2

P6 Troubleshooting

7. L0/L8/L9 malfunction

Step2

Control box A, took apart from malfunction system.

Control box B, took apart from normal system.

Malfunction estimate: Connect the compressor took apart from malfunction system with control box B, if the compressor could not start normally, that means compressor has been malfunction, or else, control box A has been malfunction.

Compressor took apart from malfunction system, needs to be checked.

Short-circuit the suction and the discharge, vacuum dry and charge 0.3kg~0.4kg R410A. Connect the U,V,W terminals to control box B.

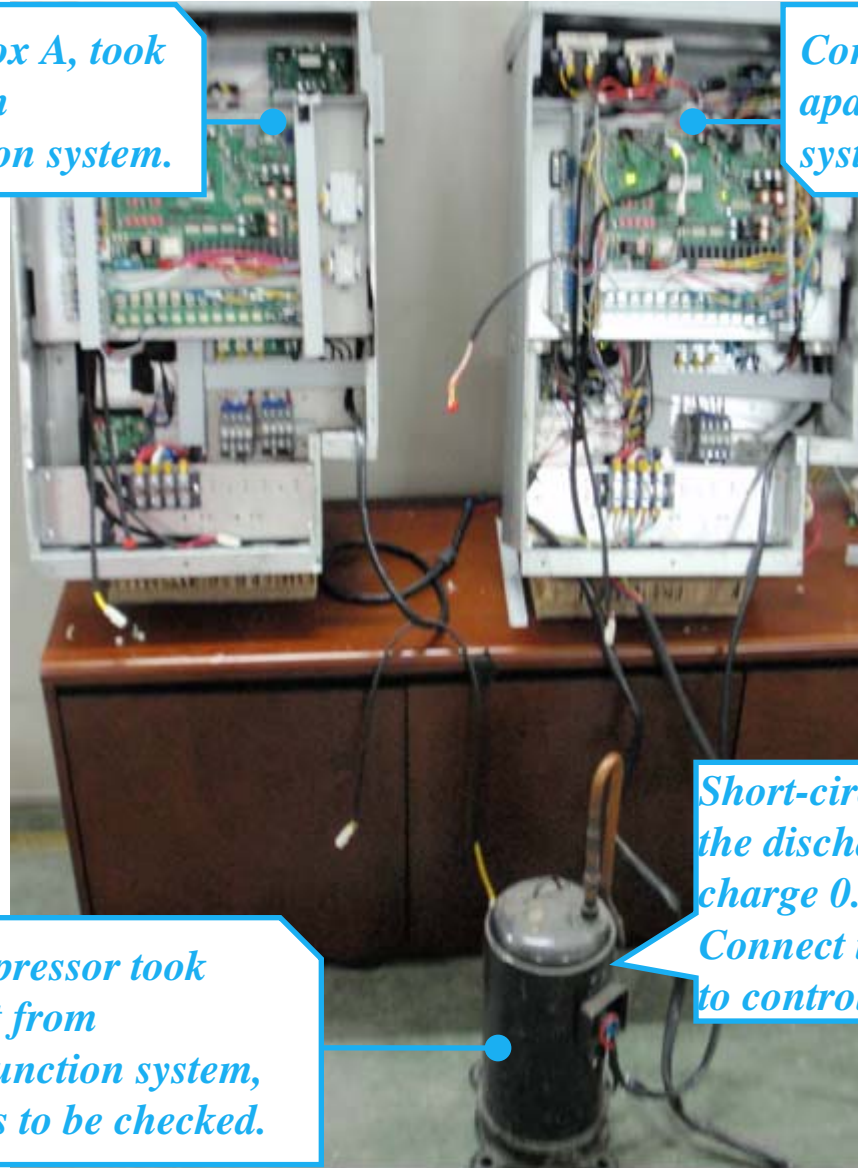

P6 Troubleshooting

7. L0/L8/L9 malfunction

Notice

Notice 1 (Beware when doing below):

1. Measure the resistance between each two of U, V, W terminals, all the resistance should be the same and equal to 0.9~5 Ohms. (Fig. A and Fig. B)

2. Measure the resistance between each of U, V, W terminals to ground (Fig. C), all the resistance should be the same and trend to be infinity (Fig. D), otherwise the compressor has been malfunction, needs to be replaced.

Notice 2:

If the frequency jumps irregularly, just pull out the T3 plug (black) immediately to protect the PCB from damage.

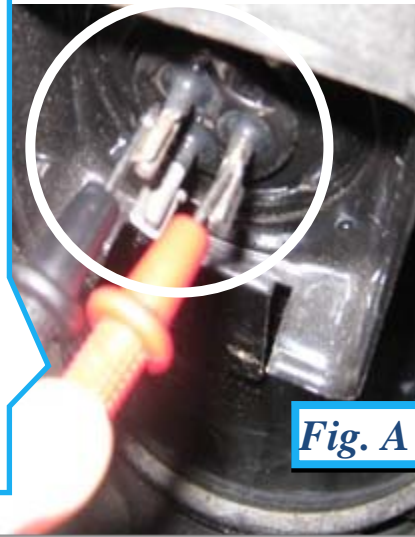

Fig. A



Fig. B

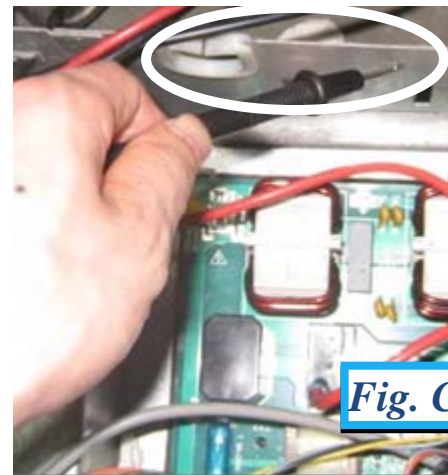
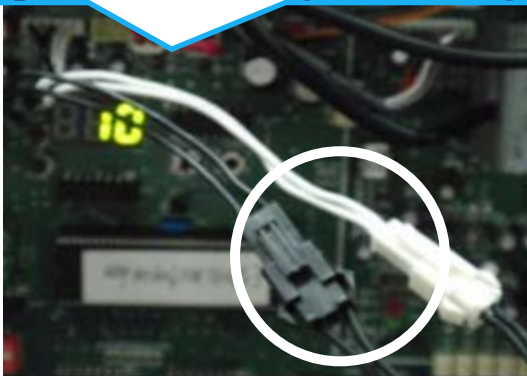

Fig. C



Fig. D



P6 Troubleshooting

8. L1/L4 troubleshooting

Step 1

1. Check the voltage at DC supply wire, normal is: 510V~580V, if lower than 510V, go to step 2.



2. Check if the wire connection of commutate circuit are loose or not.



3. If all the above are ok, then the PCB malfunction, replace it.

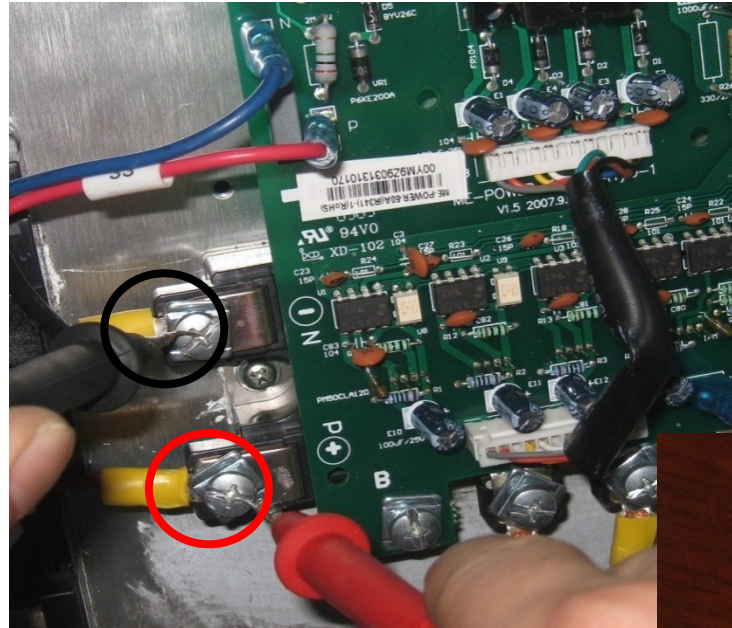

P6 Troubleshooting

8. L1/L4 troubleshooting

Step2

1. Check the voltage at DC supply wire, normal is: 510V~580V, if lower than 510V, go to step 2.

2. Check if the wire connection of commutate circuit are loose or not.

3. If all the above are ok, then the PCB malfunction, replace it.

3-Phase commutate bridge

Single-Phase commutate bridge

Filter board

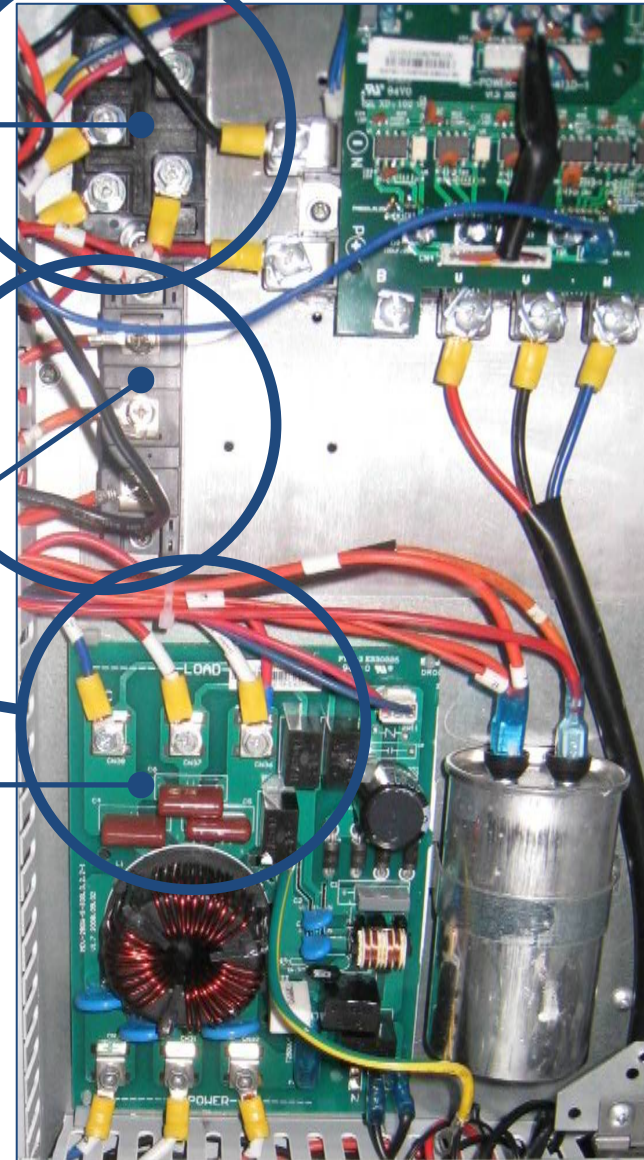

P6 Troubleshooting

8. L1/L4 troubleshooting

Step3

1. Check the voltage at DC supply wire, normal is: 510V~580V, if lower than 510V, go to step 2.



2. Check if the wire connection of commutate circuit are loose or not.



3. If all the above are ok, then the PCB malfunction, replace it.

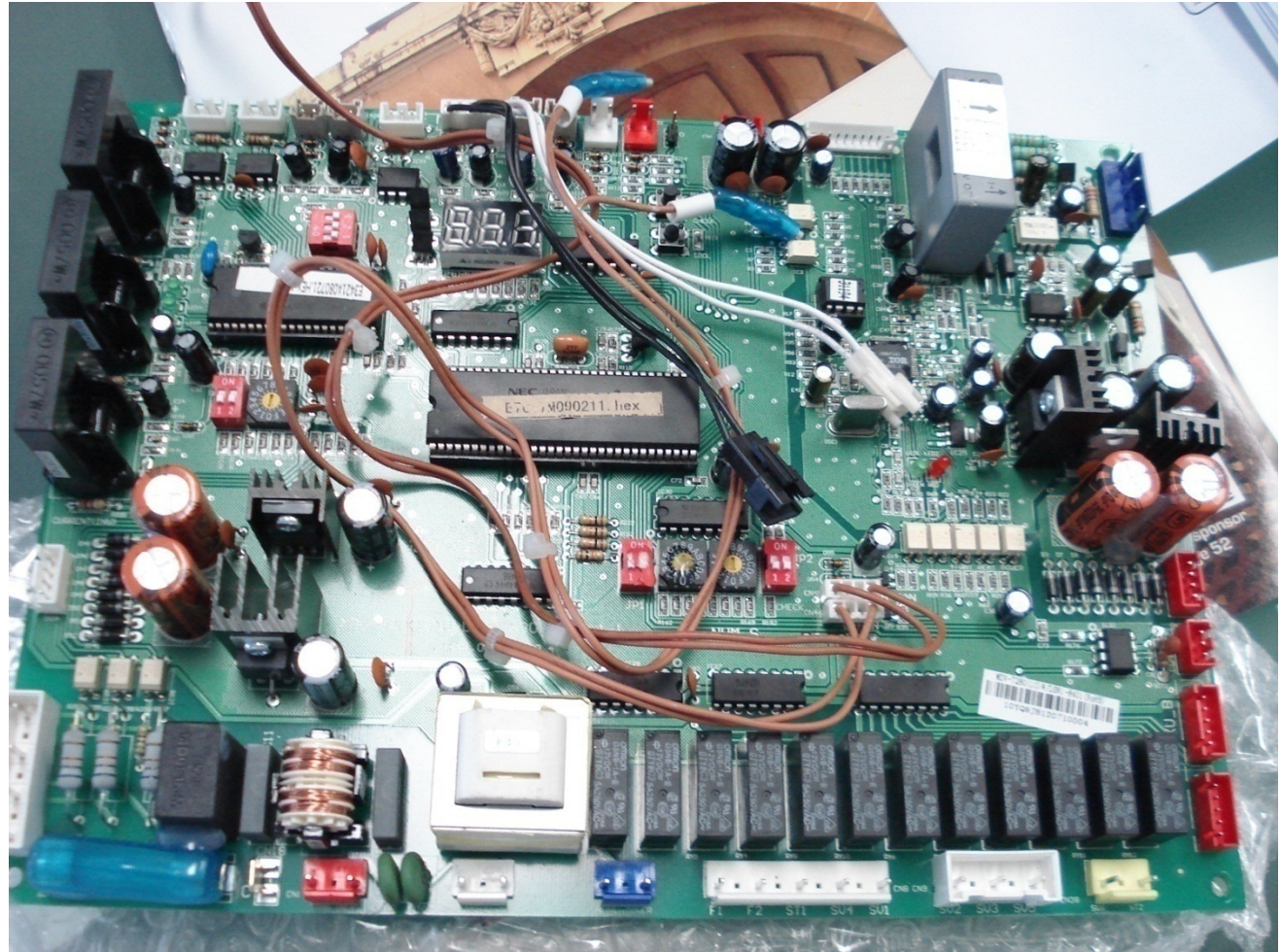

P6 Troubleshooting

9. L2 troubleshooting

Step 1

1. Measure the voltage at DC supply wire, the normal value is: 510V~580V, if higher than 580V, go to step



2. The normal voltage between two electrolytic capacitors is $510V \pm 30V$, if not in the range then the PCB has been malfunction, it needs to be replaced.

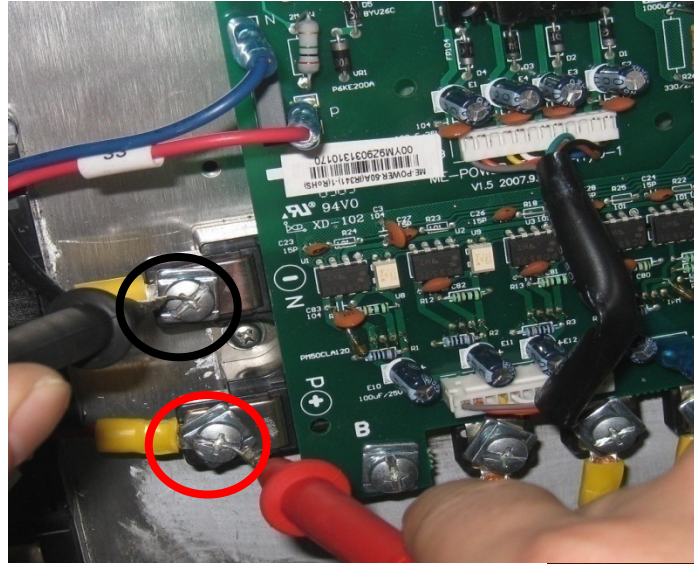

P6 Troubleshooting

9. L2 troubleshooting

Step 2

1. Measure the voltage at DC supply wire, the normal value is: 510V~580V, if higher than 580V, go to step 2.



2. The normal voltage between two electrolytic capacitors is $510V \pm 30V$, if not in the range then the PCB has been malfunction, it needs to be replaced.

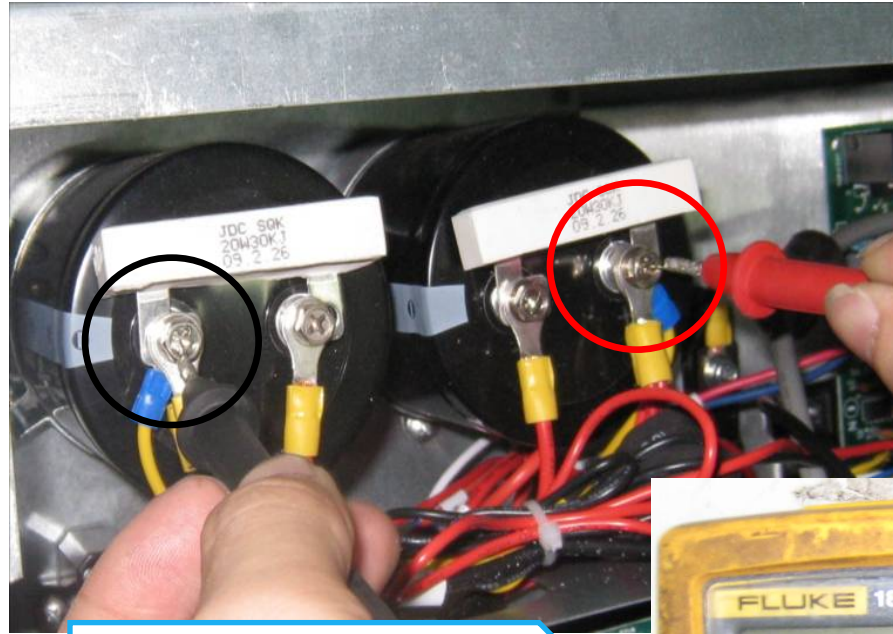

Turn the measure range of the meter to 1kV and measure the voltage between two electrolytic capacitors.

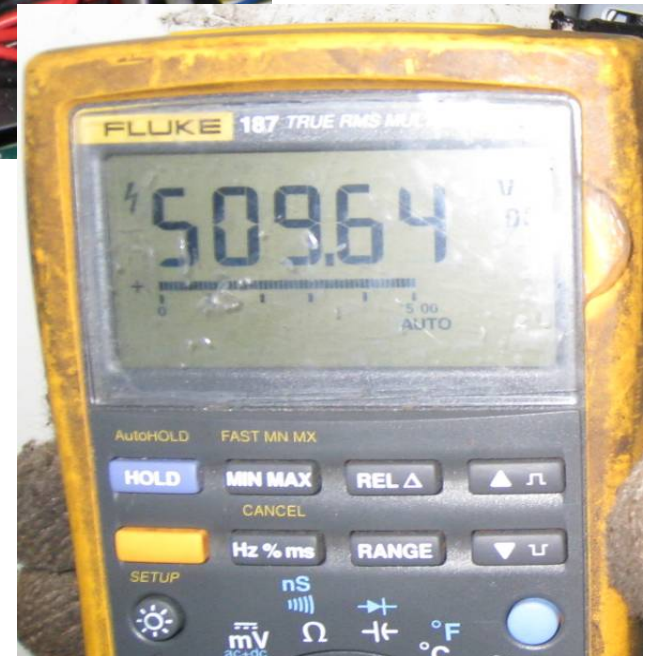

Case Study

Malfunction 1: P6 occurs after running a period of time

Step1. Confirm the PCB chip is correct.

And also check the EEPROM serial number.

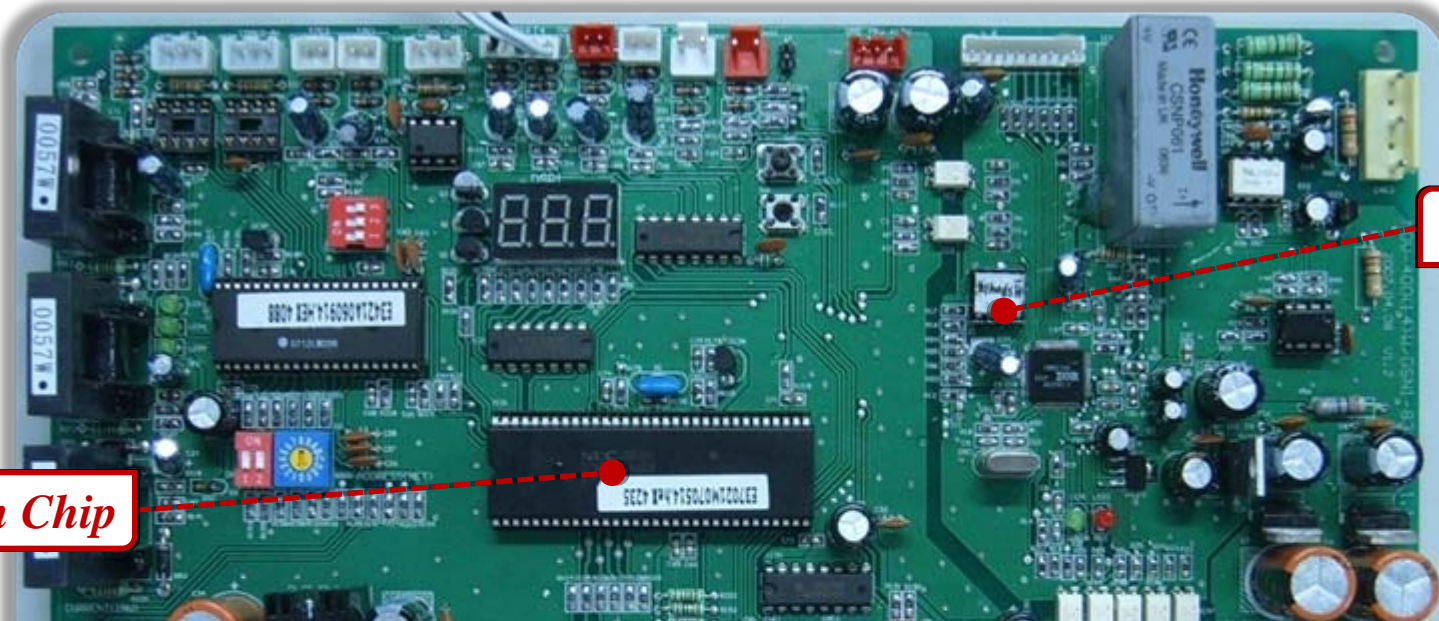

Main Chip

EEPROM

PowerSupply: 380V 50/60Hz ~ , 3N

Code of Main Chip: E37021M090829(70 _6H).hex, 6H'means 6 hours oil return operation

Code of EEPROM: 9326

Power Supply: 220V 60Hz ~, 3N

Code of Main Chip: E37021M090903(70 _6H).hex,

Code of EEPROM : 40431

Malfunction 1: P6 occurs after running a period of time

Step2. Check the inverter modular, after cutting off the power supply, and replace it if it is malfunction.

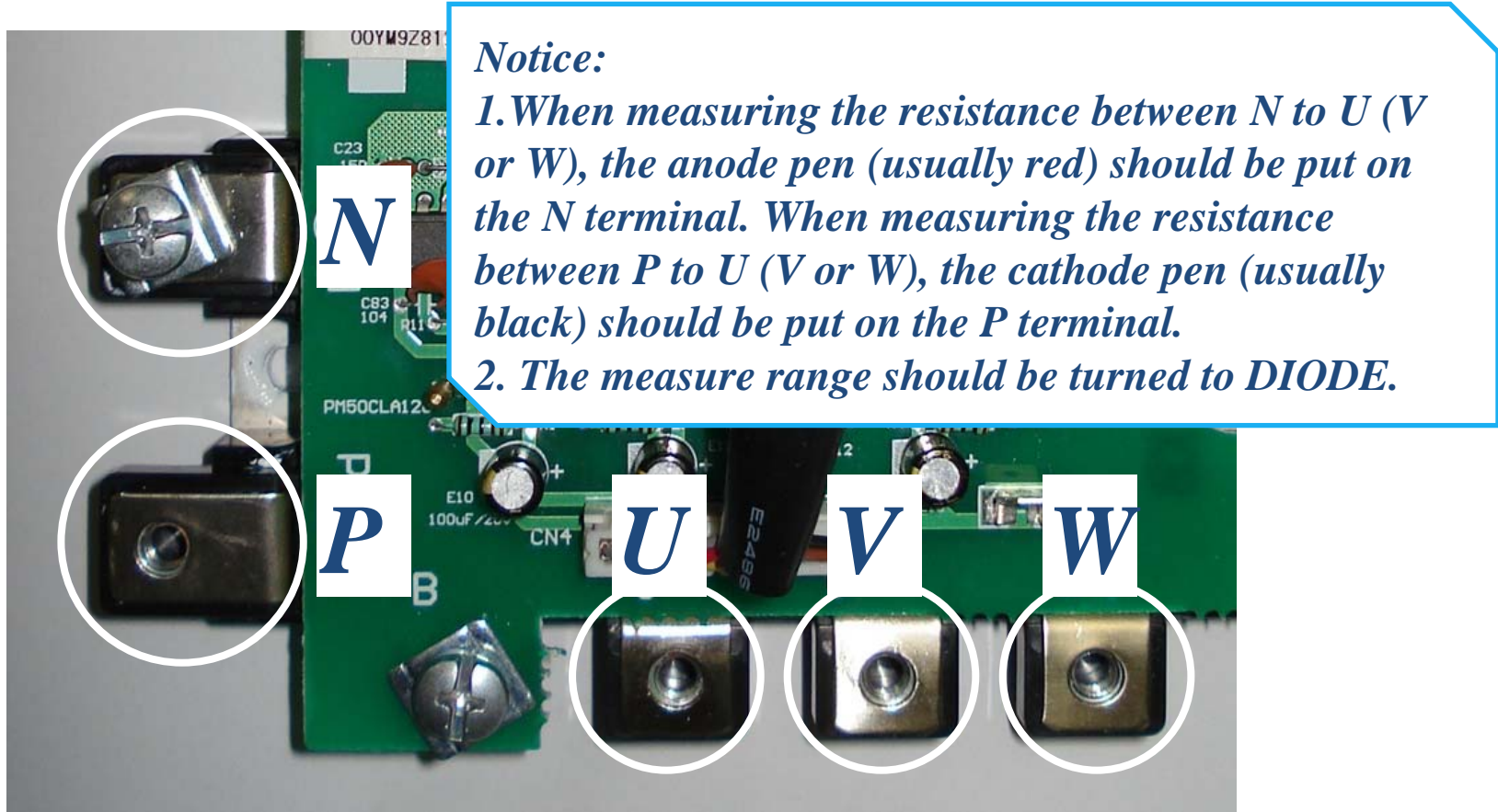

The resistance between P-U P-V P-W and N-U N-V N-W should be the same and equal to 0.387 around.

Malfunction 1: P6 occurs after running a period of time

Step3. *If inverter modular is normal, then start the system for 4 hours with all the indoor units off. By doing this, the refrigerant and the oil could be heating adequately.*

Step4. *Use a screwdriver poking at the relay to force the fixed compressor to start for about 3~5s. Because of the huge start pressure, the impurity in the compressor can be washed away.*

Step5. *After waiting for about 8 minutes, start the system again.*

Step6. *If the system running normally, that means there are some impurity in the system and needs to clean. If P6 occurs, then go to step7.*

Step7. *If the compressor frequency climbs placidly (about 1Hz per second), that means the compressor is normal. If the compressor frequency climbs very fast (up to 37Hz in 2s), then the compressor and the PCB need to be checked.*

Step8. *If compressor current is normal, then the PCB has been malfunction, needs to be replaced.*

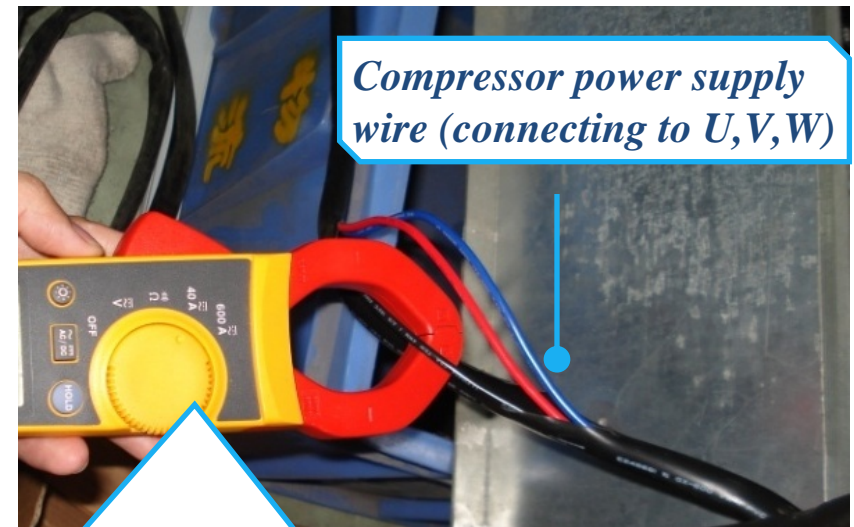

How to check a running compressor?
Using a clamp-ammeter to measure the current each of U, V, W, and the current should be the same and equal to 4A in 37Hz.

Malfunction 1: P6 occurs after running a period of time

Step9. Make a Special Compressor:

Short-circuit the suction and the discharge of the compressor, vacuum dry and charge 0.3kg~0.4kg R410A. Connect the U,V,W terminals to the control box which is need to be checked. If the compressor could not start, then the PCB has been malfunction, replace it.

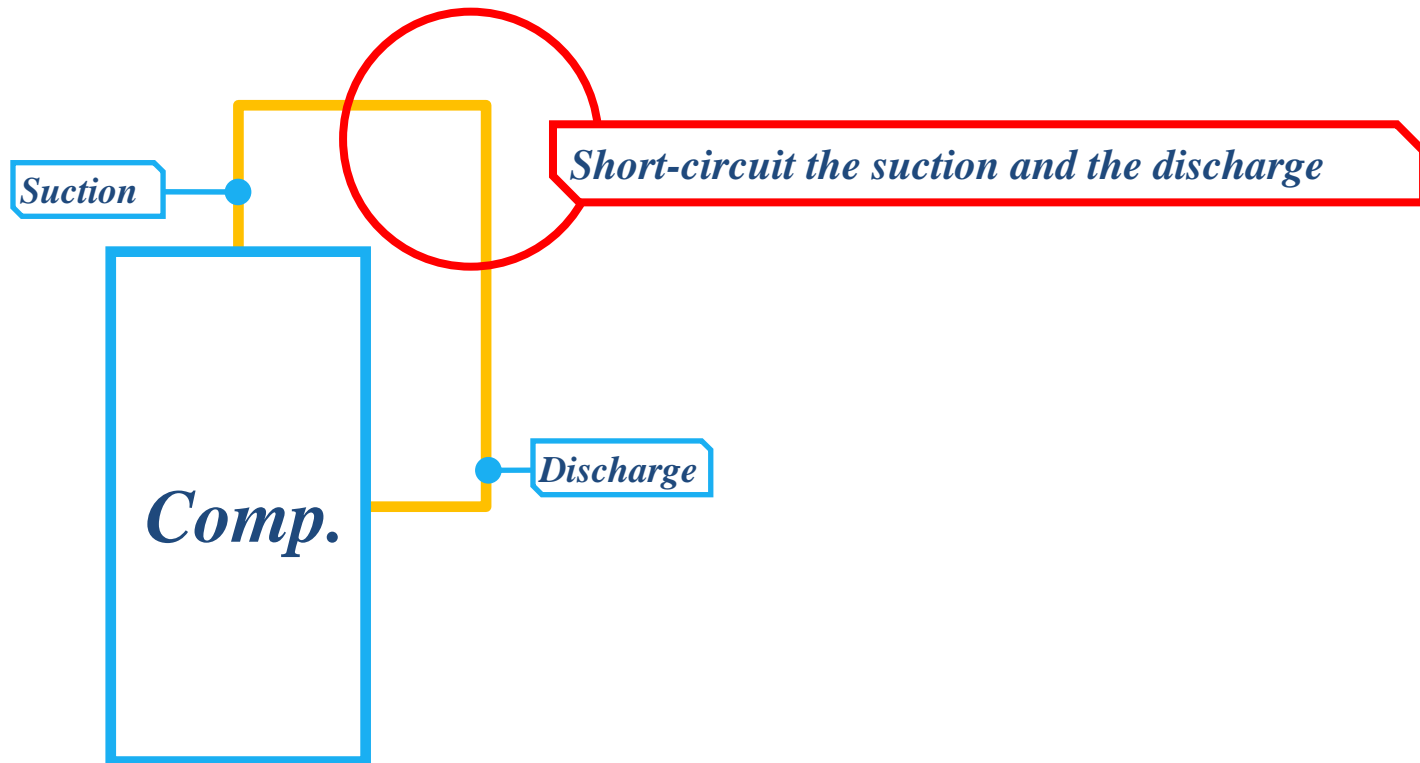

Malfunction 2: P6 occurs immediately when power on

Phenomenon A:

LED 1 (Green) Flash 8 times and stop for 1s, then repeat — Inverter modular malfunction

LED 2 (Red) On — Malfunction

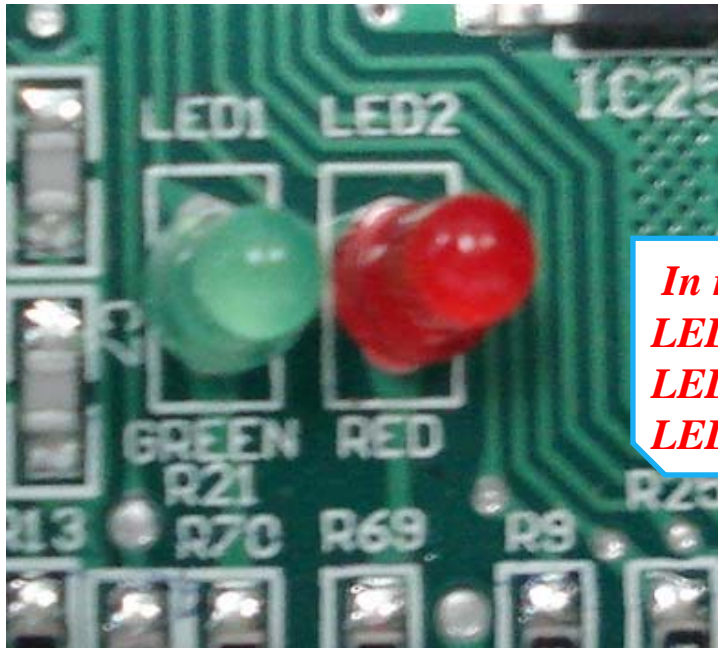

In normal situation:

LED 1: Flash in 1Hz (slowly flash) when standby

LED 1: On when running

LED 2: Off

Malfunction 2: P6 occurs immediately when power on

Step1. Measure the voltage between 0 terminal of CN4 on PCB and ground.

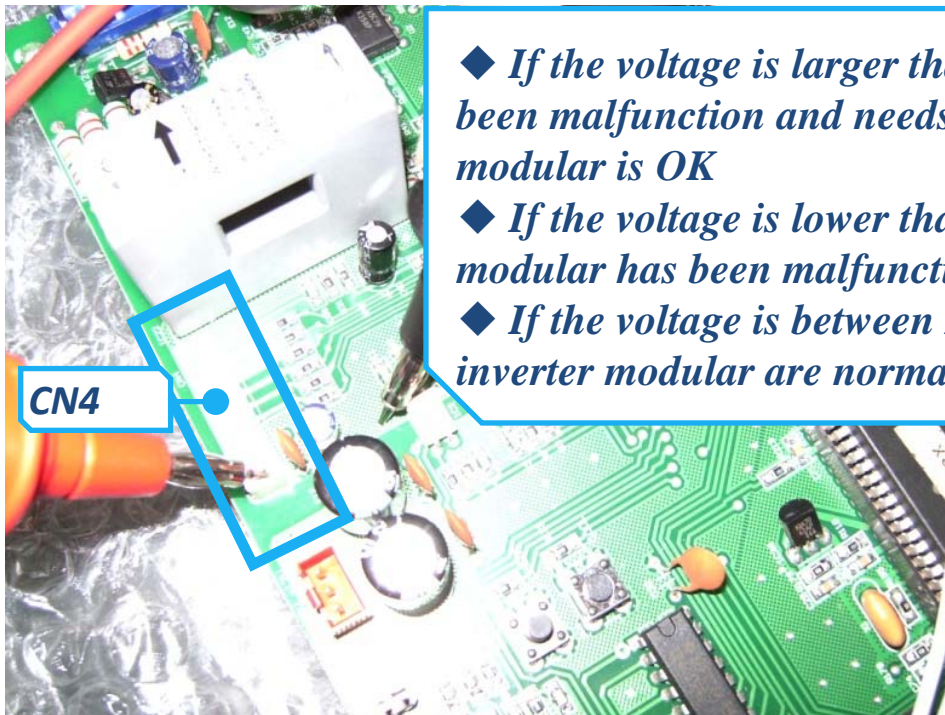

- ◆ *If the voltage is larger than 2.7V, that means PCB has been malfunction and needs to be replaced, but inverter modular is OK*
- ◆ *If the voltage is lower than 2.7V, that means inverter modular has been malfunction and needs to be replaced.*
- ◆ *If the voltage is between 2.7V and 2.8V, both PCB and inverter modular are normal.*

Step2. If step1 is pass, then check the inverter modular (refer to page 6 and 17 for details).

Step3. Check the wire connection of the inverter modular. Are there something loose or not connected (P1 is usually forgotten to connect)?

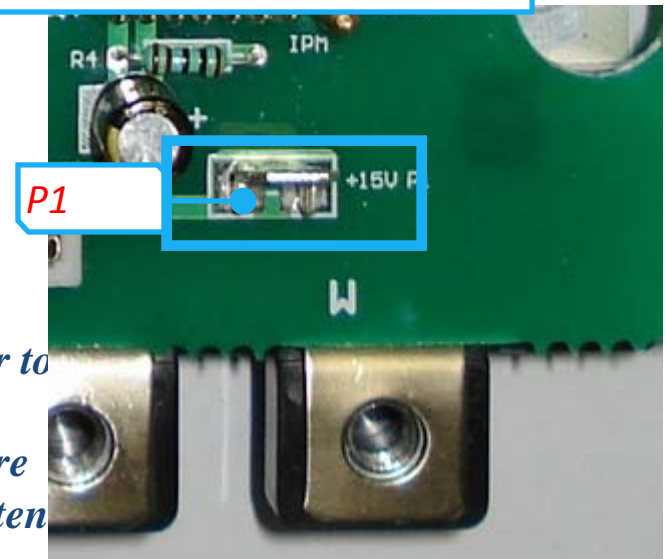

Malfunction 2: P6 occurs immediately when power on

Phenomenon B:

LED 1 (Green) Flash 9 times and stop for 1s, then repeat — Low voltage protection

LED 2 (Red) On — Malfunction

There are three situation could cause low voltage protection.

◆ 1、 *The voltage between two electrolytic capacitors is too low (lower than 450V), so that the relay could not draw in (relay draws in after power on for 2s). If the relay could not draw in, then the PCB or PTC has been malfunction, needs to be replaced.*

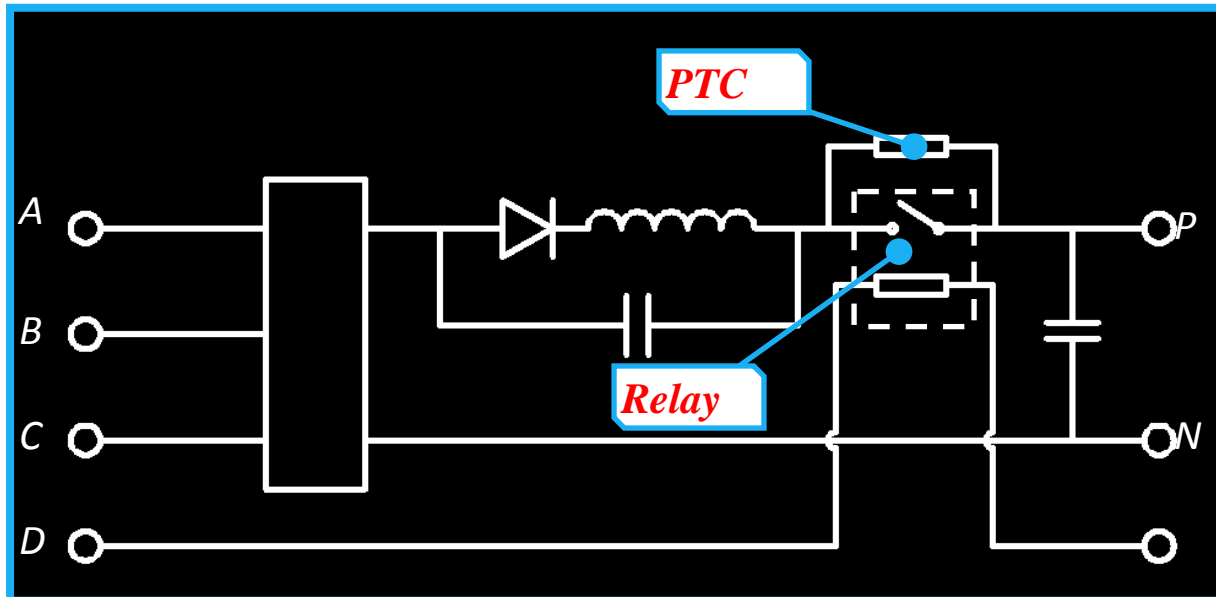

Malfunction 2: P6 occurs immediately when power on

- ◆ *Some wire are loose or some spigots are not connected on the inverter modular.*
- ◆ *PCB has been malfunction.*

The normal voltage between P and N of CN12 on PCB should be 450V~570V, and if the voltage between P(or N) and middle terminal is 15V when P6 shows, that means PCB has been malfunction, needs to be replaced.

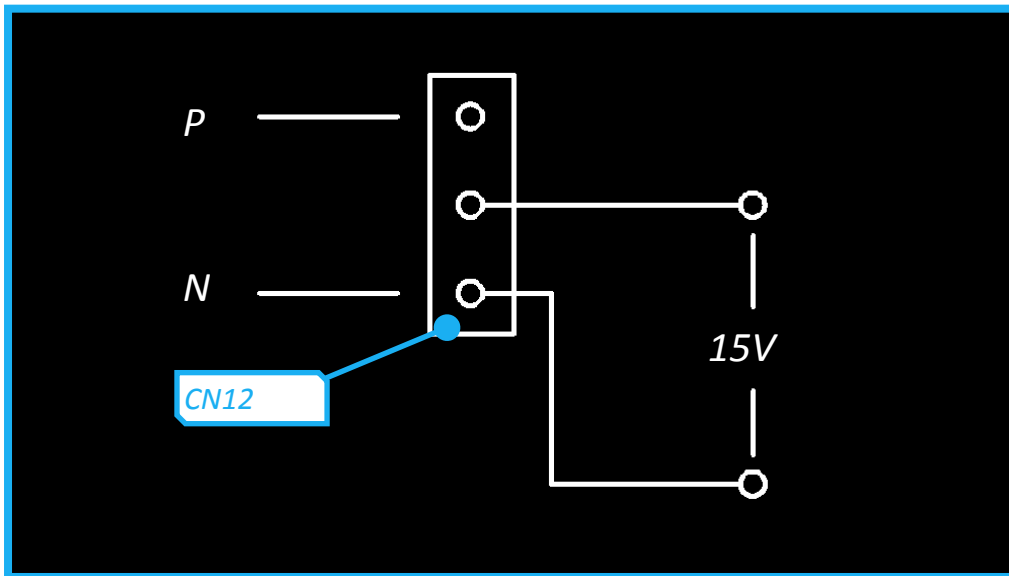

Malfunction 2: P6 occurs immediately when power on

- ◆ *Phenomenon C (seldom):*

 - LED 1 (Green) Flash 10 times and stop for 1s, then repeat — High voltage protection*

 - LED 2 (Red) On — Malfunction*

- ◆ *There are two situation could cause low voltage protection.*

 - ◆ *Voltage of the power supply is higher than 440V.*

 - ◆ *PCB has been malfunction, needs to be replaced.*

Malfunction 2: P6 occurs immediately when power on

For phenomenon 2 and 3, there is another way to check: measure the voltage between C37 and ground, if the value equal to 0.6V, then the power supply is ok, PCB has been malfunction, needs to be replaced.

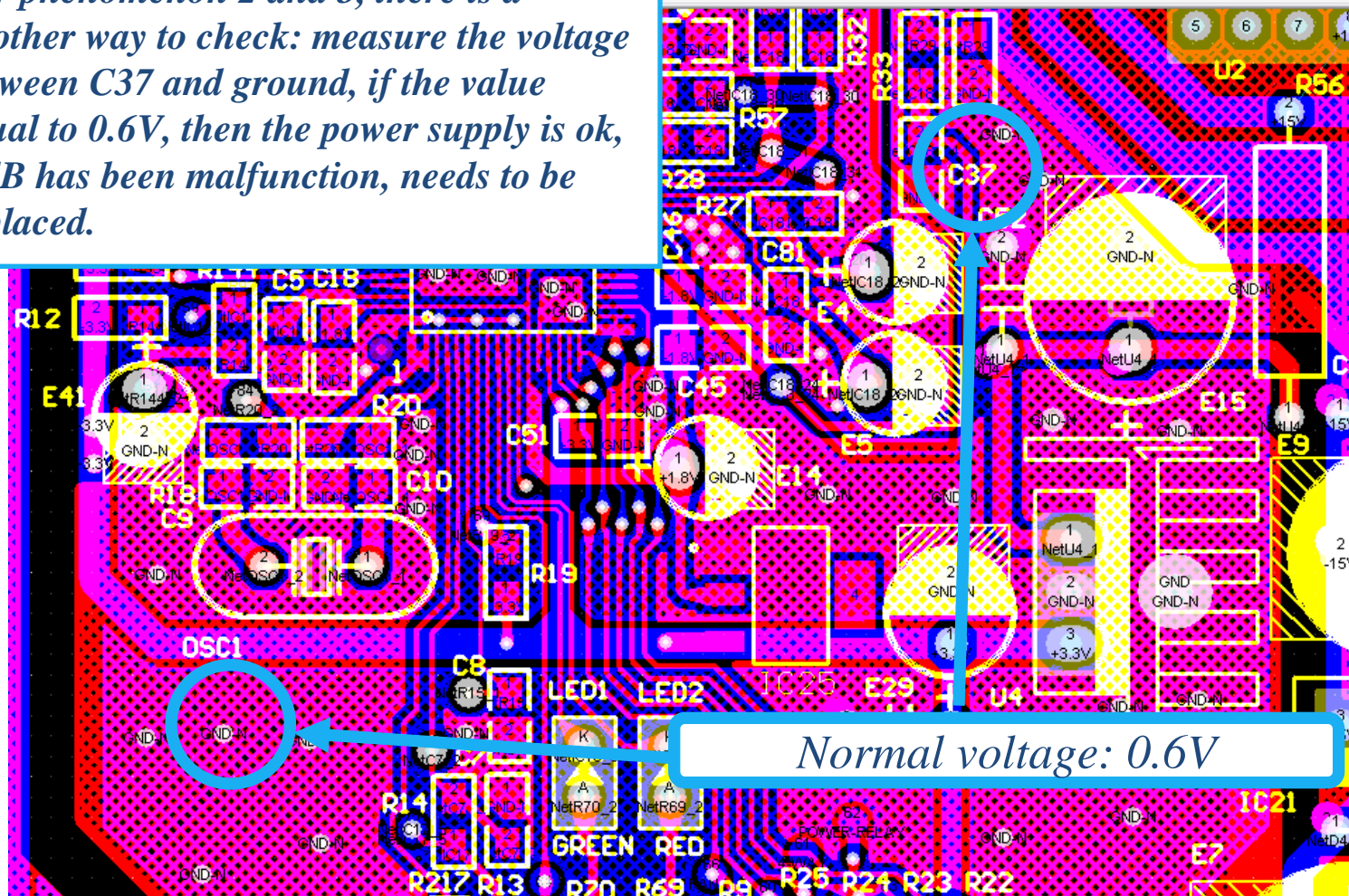

Malfunction 2: P6 occurs immediately when power on

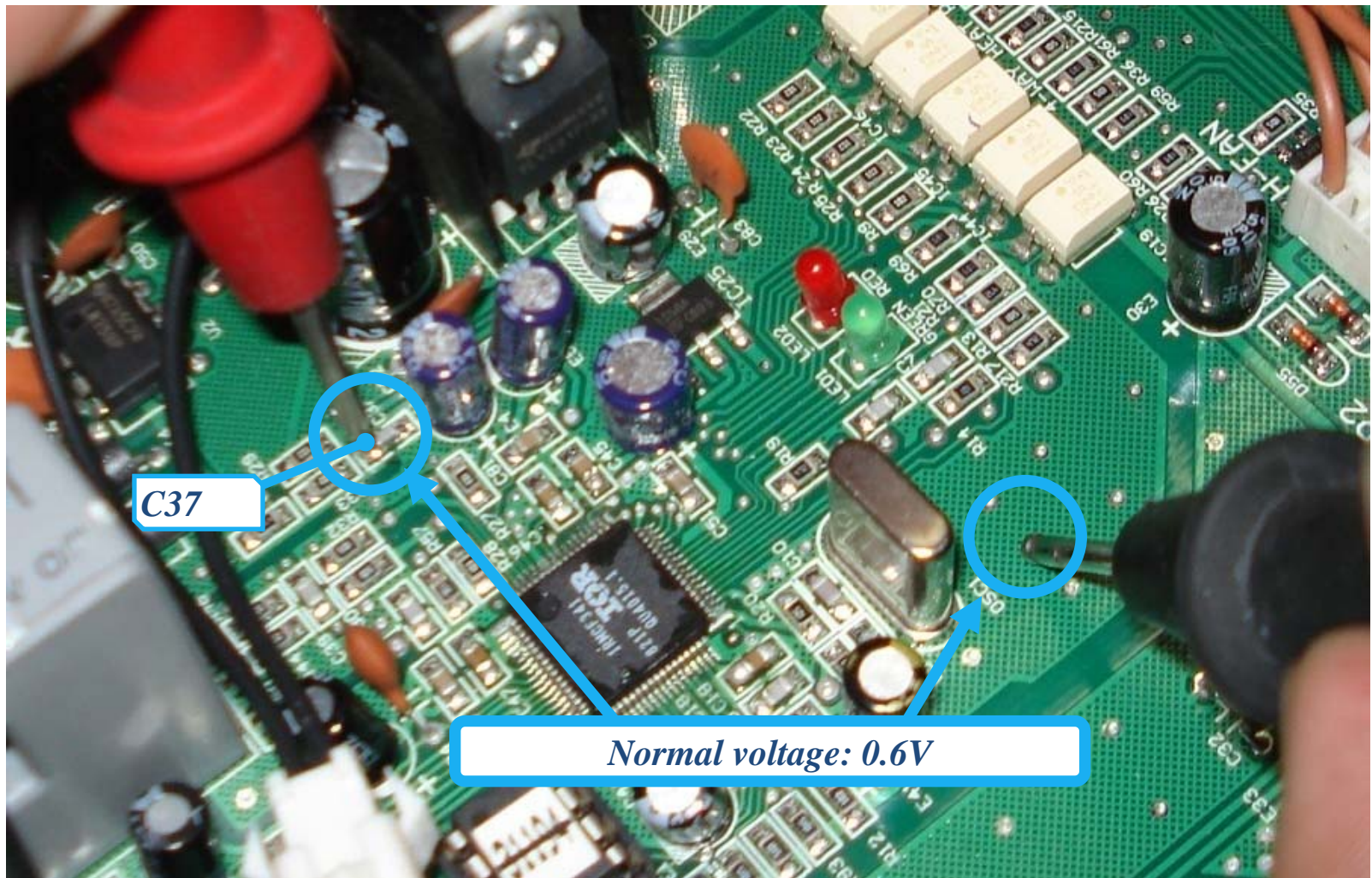

Malfunction 3: Frequency jumps irregularly when startup

◆ *The troubleshooting is the same as Malfunction1.*

Thank you!