



MULTI-POSITION INDUCED DRAFT GAS FURNACES

220V-50 Hz-1PH

NOMINAL CAPACITIES:

66,000 - 132,000 BTU/H (19.3 - 38.7 kW)

■ Contents

Dimensions	2
Product Specifications.....	3
Air Flow	5

■ Standard Features

- Energy-saving, reliable direct spark igniter
- Energy-saving PSC, three-speed, direct-drive blower motors
- Corrosion-resistant, stainless steel tubular heat exchanger
- Quiet, corrosion-resistant, rotating induced-draft blower for venting through the top or right side
- Integrated furnace control with diagnostics
- Low-voltage terminal blocks
- Combination redundant gas valve and regulator
- Aluminized steel in-shot burners
- Blower door safety switch
- Multiple flame roll-out switches
- Outlet air limit switch
- Pressure switch for proof of combustion air

■ Cabinet Features

- Heavy-gauge, reinforced, wrap-around insulated, steel cabinet with durable baked-enamel finish
- Foil-face insulation lines the heat exchanger compartment
- Coil and furnace fit flush for easy installation
- Multi-position installation — upflow, horizontal right or left
- Convenient left or right connection for gas and electric service
- All models can be vertically vented with a water heater using a B-1 vent
- Bottom or side air inlet; Removable, solid bottom

■ Accessories

- LP Conversion Kit for both Honeywell and White-Rodgers valves (LPM-01)
- Sidewall venting (SVB-80-5)

DIMENSIONS (MM)

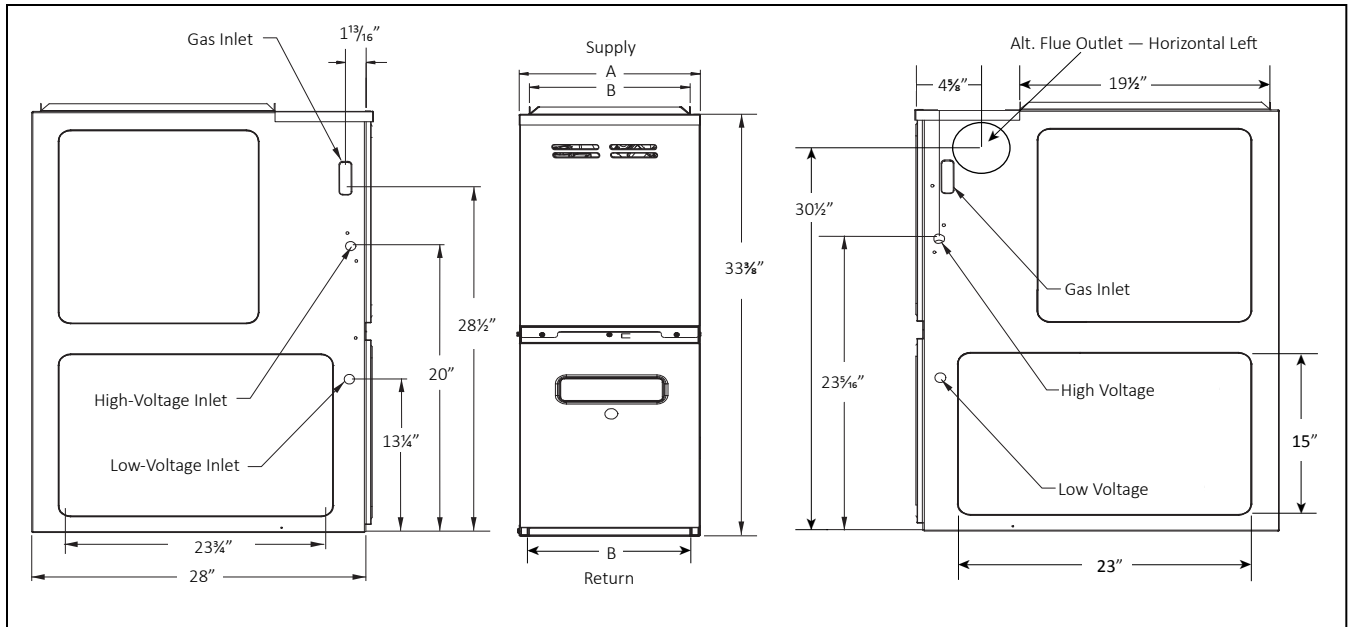

MODEL	A (MM)	B (MM)
DMP075-32	14" (356)	12 1/2" (318)
DMP100-42	17 1/2" (445)	16" (406)

MODEL	A (MM)	B (MM)
DMP125-52	21" (533)	19 1/2" (495)
DMP150-52	24 1/2" (622)	23" (584)

NOTES

- Line voltage wiring can enter through the right or left side of furnace.
Low-voltage wiring can enter through the right or left side of furnace.
- Conversion kits for high-altitude (7,000+ ft) natural gas operation are available.
Contact your Goodman distributor or dealer for details.

CLEARANCES FOR COMBUSTIBLE MATERIAL (MM)

SIDES	REAR	FRONT ¹	VENT ²		TOP
			SW	B-1	
1" (25)	0"	3" (76)	6" (152)	1" (25)	1" (25)

¹ 24" (610 mm) clearance for serviceability recommended.

² Single Wall Vent (SW) to be used only as a connector.

	DMP075-32	DMP100-42	DMP125-52	DMP150-52
HEATING CAPACITY				
Input BTU/h ¹ [kW-h]	66,000 [19.3]	88,000 [25.8]	110,000 [32.2]	132,000 [38.7]
Natural Gas Output BTU/h ¹ [kW-h]	52,800 [15.5]	88,000 [25.8]	88,000 [25.8]	105,600 [30.9]
Steady State Efficiency (SSE)	80%	80%	80%	80%
Cooling SCFM @ 0.5" ESP [Cooling Cubic Meters / Hr.]	1,200 [2,039]	1,560 [2,650]	1,960 [3,313]	1,900 [3,228]
Temperature Rise Range °F [°C]	35-65 [19-36]	40-70 [22-39]	35-65 [19-36]	35-65 [19-36]
CIRCULATOR BLOWER				
Size: Dia." x Width" [mm]	10" x 6" [254 x 152]	10" x 8" [254 x 203]	10" x 10" [254 x 254]	11" x 10" [279 x 254]
Horsepower	¾	¾	1	1
Speeds	3	3	3	3
Vent Diameter In. [mm]	4" [102]	4" [102]	4" [102]	4" [102]
No. of Burners	3	4	5	6
Disposable Filter Size (in ² [cm ²])	580 [3742]	770 [4968]	960 [6194]	960 [6194]
GAS SERVICE CONNECTION				
	½" BPT	½" BPT	½" BPT	½" BPT
ELECTRICAL DATA				
Power Supply [Volts/Hz/Ph]	220 / 50 / 1	220 / 50 / 1	220 / 50 / 1	220 / 50 / 1
FLA	5.51	5.51	7.92	7.92
Min. Circuit Ampacity ²	7	7	9.7	9.7
Max. Overcurrent Protection [amps] ³	15	15	15	15
SHIP WEIGHT (LBS [KG])				
	130 [59]	153 [69]	163 [74]	173 [78]

¹ Natural Gas BTU/h. For altitudes above 2,000', reduce input rating 4% for each 1,000' above sea level.

² Minimum Circuit Ampacity = (1.25 x Circulator Blower Amps) + ID Blower amps. Wire size should be determined in accordance with National Electrical Codes. Extensive wire runs will require larger wire sizes.

³ Refers to maximum recommended fuse or circuit breaker size. May use fuses or HACR-type circuit breakers of the same size as noted.

NOTES

- All furnaces are manufactured for use on 230 VAC, 50 Hz, single-phase electrical supply.
- Gas Service Connection ½" BPT
- Important: Size fuses and wires properly and make electrical connections in accordance with all existing local codes.

AIRFLOW DATA

(STANDARD CFM & TEMPERATURE RISE VS. EXTERNAL STATIC PRESSURE)

FURNACE MODEL MOTOR HP (RISE RANGE)	MOTOR SPEED	TONS AC AT 0.5" ESP	EXTERNAL STATIC PRESSURE (INCHES WATER COLUMN)															
			0.1		0.2		0.3		0.4		0.5		0.6		0.7		0.8	
			CFM	RISE	CFM	RISE	CFM	RISE	CFM	RISE	CFM	RISE	CFM	RISE	CFM	CFM	CFM	
DMP075-32	High	3.0	1289	38	1243	39	1243	39	1228	40	1204	41	1187	1154	1120			
	Med	2.5	1267	39	1247	39	1243	39	1227	40	1186	41	1175	1154	1109			
	Low	2.0	1173	42	1140	43	1129	43	1107	44	1078	45	1054	1024	987			
DMP100-42	High	4.0	1683	39	1650	40	1631	40	1593	41	1560	42	1526	1478	1431			
	Med	3.5	1419	46	1403	46	1378	47	1354	48	1328	49	1296	1252	1209			
	Low	3.0	1268	51	1244	52	1226	53	1198	54	1158	56	1125	1093	1064			
DMP125-52	High	5.0	2149	38	2127	38	2051	40	1988	41	1928	42	1877	1781	1663			
	Med	4.0	1880	43	1806	45	1762	46	1718	47	1654	49	1588	1533	1481			
	Low	3.5	1629	50	1587	51	1537	53	1499	54	1460	56	1406	1342	1299			
DMP150-52	High	5.0	2125	46	2074	47	2030	48	1951	50	1901	51	1843	1766	1675			
	Med	4.0	1753	56	1719	57	1685	58	1620	60	1558	63	1513	1467	1378			
	Low	3.5	1534	64	1481	66	1442	68	1399	70	1358	72	1297	1238	1191			

NOTES

1. CFM in chart is without filter(s). Filters do not ship with this furnace, but must be provided by the installer. If the furnace requires two return filters, this chart assumes both filters are installed.
2. All furnaces ship as high-speed cooling. Installer must adjust blower cooling speed as needed.
3. For most jobs, about 400 CFM per ton when cooling is desirable.
4. INSTALLATION IS TO BE ADJUSTED TO OBTAIN TEMPERATURE RISE WITHIN THE RANGE SPECIFIED ON THE RATING PLATE.
5. The chart is for information only. For satisfactory operation, external static pressure must not exceed value shown on the rating plate. The shaded area indicates ranges in excess of maximum static pressure allowed when heating.