

**DAIKIN**

R407C

# TECHNICAL MANUAL

## Packaged Air Conditioner Rooftop A series

**UATP-A and UATYP-A Series**

**— Cooling only & Heatpump [50Hz] —**





---

# Table of Contents

<b>Nomenclature</b> .....	<b>1</b>
Product Line-Up.....	2
<b>Application Information</b> .....	<b>3</b>
Operating Range .....	3
Refrigerant Circuit Diagrams .....	4
Controllers .....	18
Precaution & Installation.....	22
<b>Sound Data</b> .....	<b>38</b>
NC Curve.....	38
<b>Selection Process</b> .....	<b>44</b>
<b>Engineering &amp; Physical Data</b> .....	<b>55</b>
<b>Performance Data</b> .....	<b>64</b>
Calculation Steps.....	64
Performance Tables.....	70
<b>Outline &amp; Dimension</b> .....	<b>90</b>
<b>Wiring Diagram</b> .....	<b>94</b>
<b>Service &amp; Maintenance</b> .....	<b>103</b>
<b>Troubleshooting</b> .....	<b>106</b>

---

# Nomenclature

UAT Y P 100 A G X Y1

**Product Type**

UAT : Rooftop

**Model Type**

“ ” : Cooling

Y : Heatpump

**Refrigerant**

P : R407C

Q : R410A

“ ” : R22

**Size**

100 : 100,000 Btu/h

**Product series**

A : A Series

**Revision/Specification**

9 : Mechanical Control

“ ” : PCB Control

**Power Supply**

Y1 : 380~415V/3Ph/50Hz

**Product Origin**

X : OYLM

**Product Specification Variation**

G : Gold Fin (Outdoor Coil)

“ ” : Bare Fin (Outdoor Coil)

Product Line-Up

UAT(Y)P

Nomenclature		Classification												
		SLM Controller	Seq. Controller	Capillary Tube	Thermal Expansion Valve (TVX)	Normal Fin	Blue (Hydrophilic) Fin	Gold (NA549) Fin	Scroll Compressor	Air Filter	Down Flow	Side Flow	Convertible	Filter Drier
COOLING	UATP60AGXY1	X			X		X	X	X	X		X		X
	UATP80AGXY1	X		X			X	X	X	X		X	X	X
	UATP100AGXY1	X		X			X	X	X	X		X	X	X
	UATP120AGXY1	X			X		X	X	X	X		X	X	X
	UATP150AGXY1		X	X		X		X	X	X		X	X	X
	UATP200AGXY1		X	X		X		X	X	X		X	X	X
	UATP250AGXY1		X		X		X	X	X	X		X		X
	UATP300AGXY1		X		X		X	X	X	X		X		X
	UATP360AGXY1		X		X			X	X	X		X		X
	UATP420AGXY1		X		X			X	X	X		X		X
HEATPUMP	UATYP60AGXY1	X			X		X	X	X	X		X		X
	UATYP80AGXY1	X			X		X	X	X	X		X	X	X
	UATYP100AGXY1	X			X		X	X	X	X		X	X	X
	UATYP120AGXY1	X			X		X	X	X	X		X	X	X
	UATYP150AGXY1		X		X		X	X	X	X		X	X	X
	UATYP200AGXY1		X		X		X	X	X	X		X	X	X
	UATYP250AGXY1		X		X		X	X	X	X		X		X
	UATYP300AGXY1		X		X		X	X	X	X		X		X
	UATYP360AGXY1		X		X			X	X	X		X		X
	UATYP420AGXY1		X		X			X	X	X		X		X

# Application Information

## Operating Range

Ensure the operating temperature is in allowable range.

### Cooling

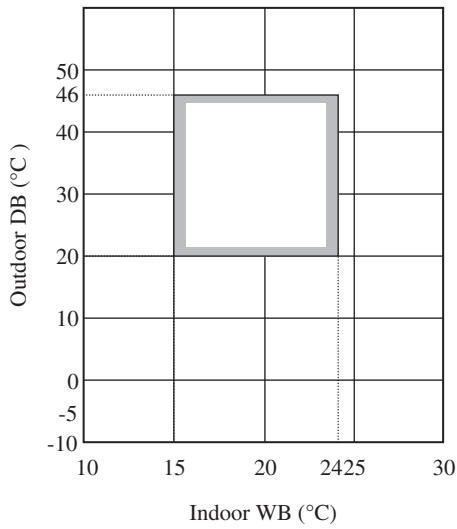

- Note:**
- WB = Wet Bulb
  - DB = Dry Bulb

**⚠ Caution :**

The use of your air conditioner outside the range of working temperature and humidity can result in serious failure.

### Heating

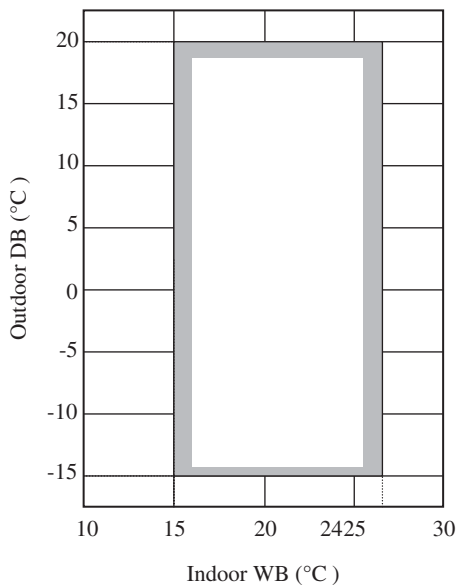

- Note:**
- WB = Wet Bulb
  - DB = Dry Bulb

**⚠ Caution :**

The use of your air conditioner outside the range of working temperature and humidity can result in serious failure.

## Refrigerant Circuit Diagrams

Model: UATP60AGXY1

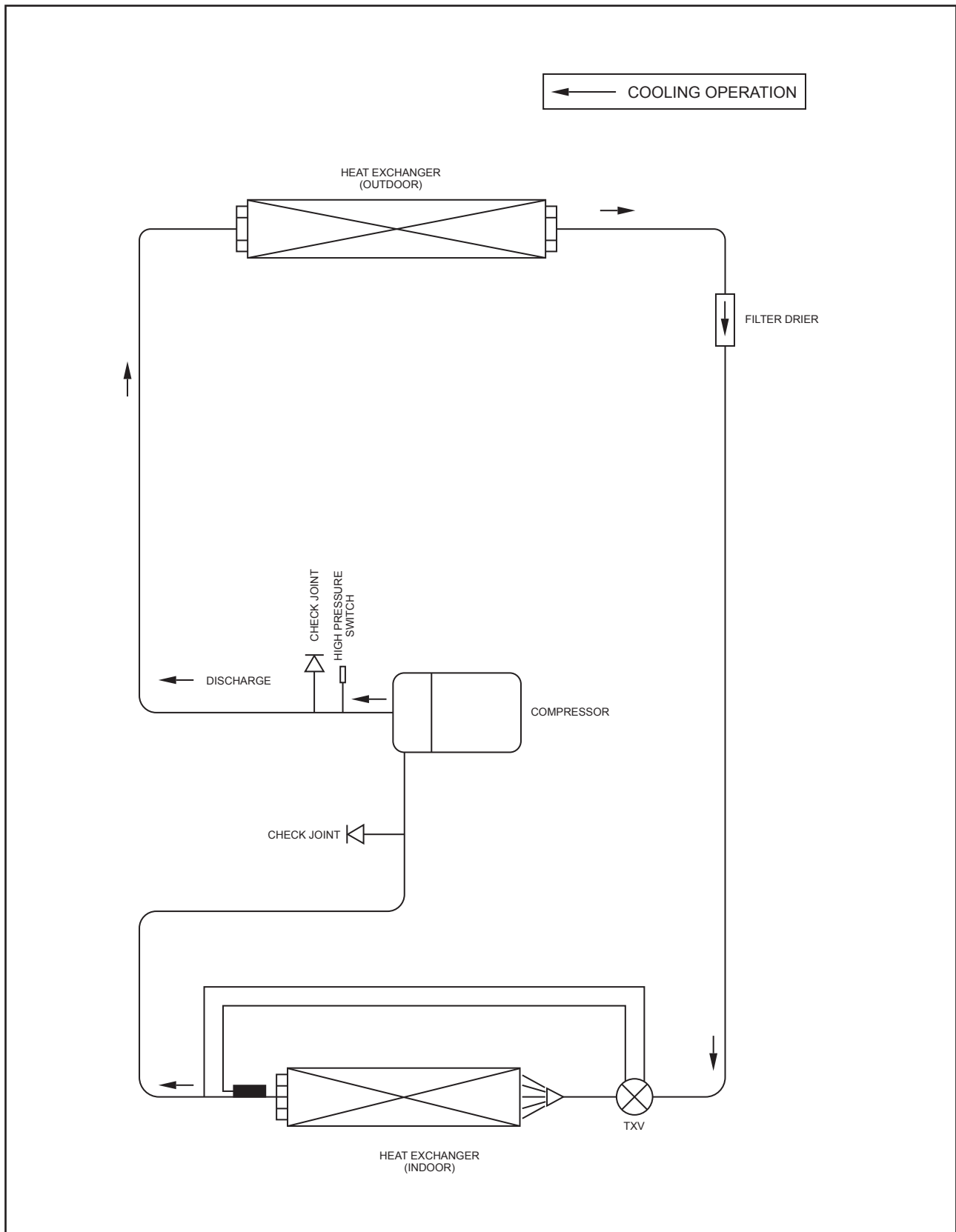

Model: UATP80/100AGXY1

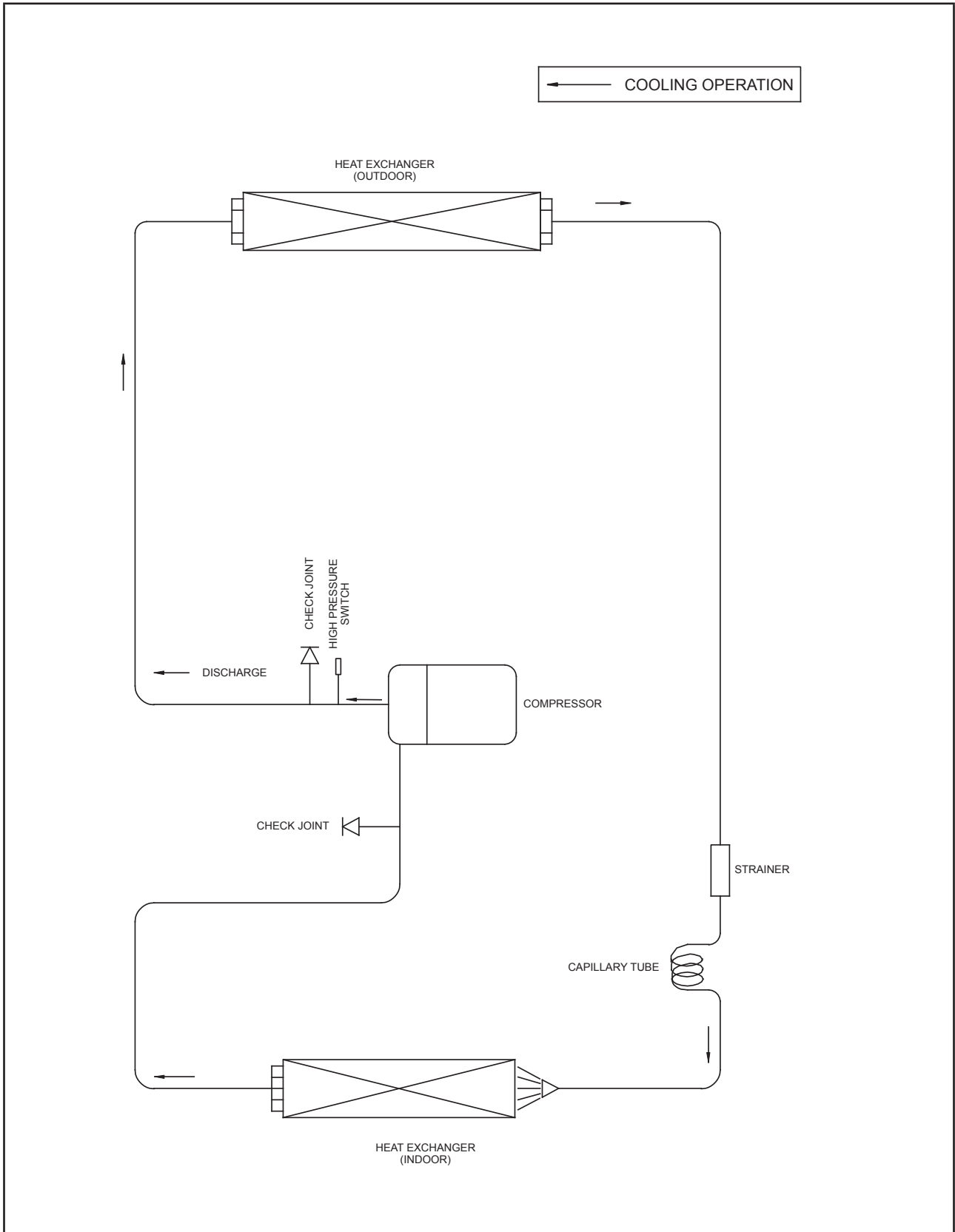

Model: UATP120AGXY1

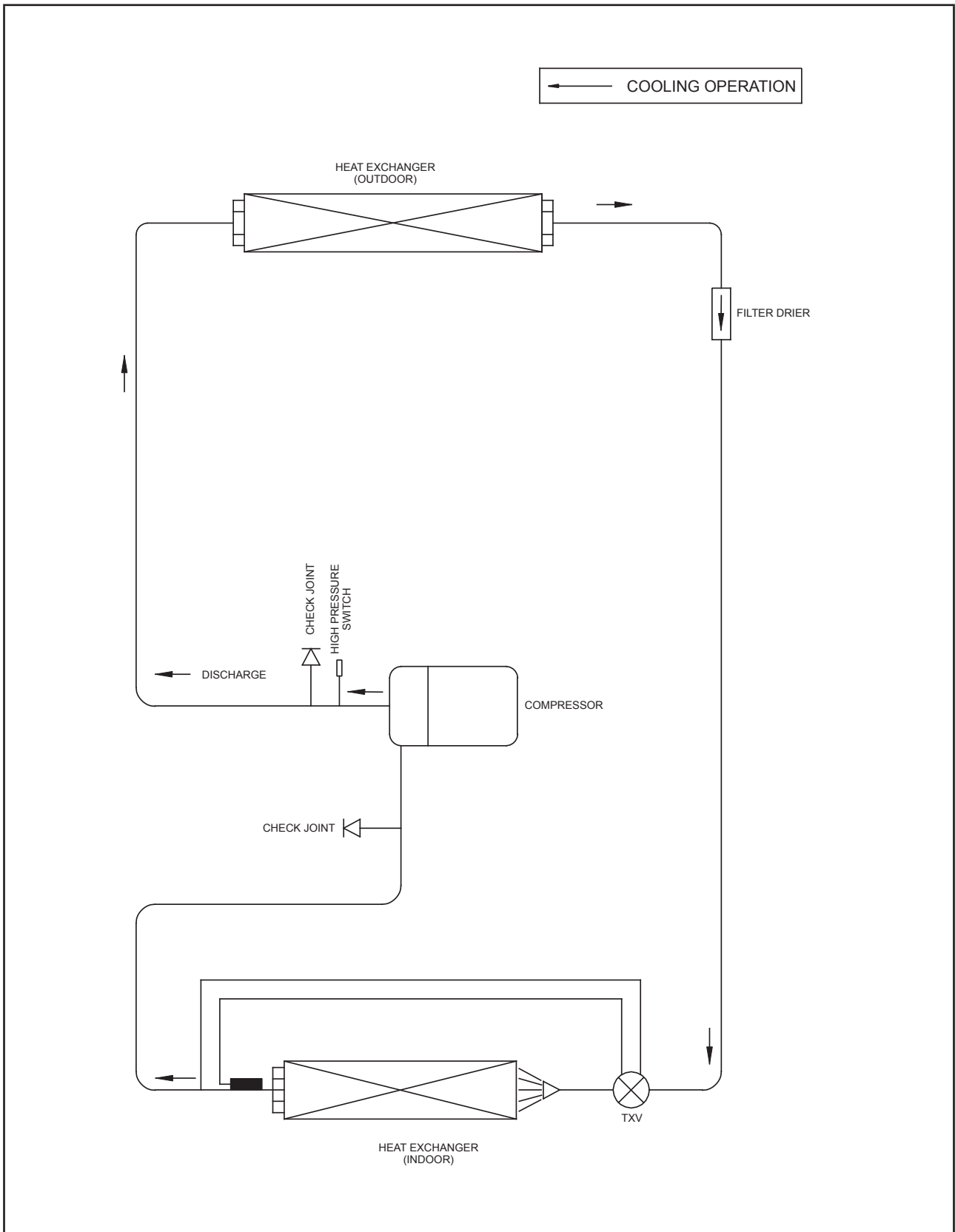

Model: UATP150/200AGXY1

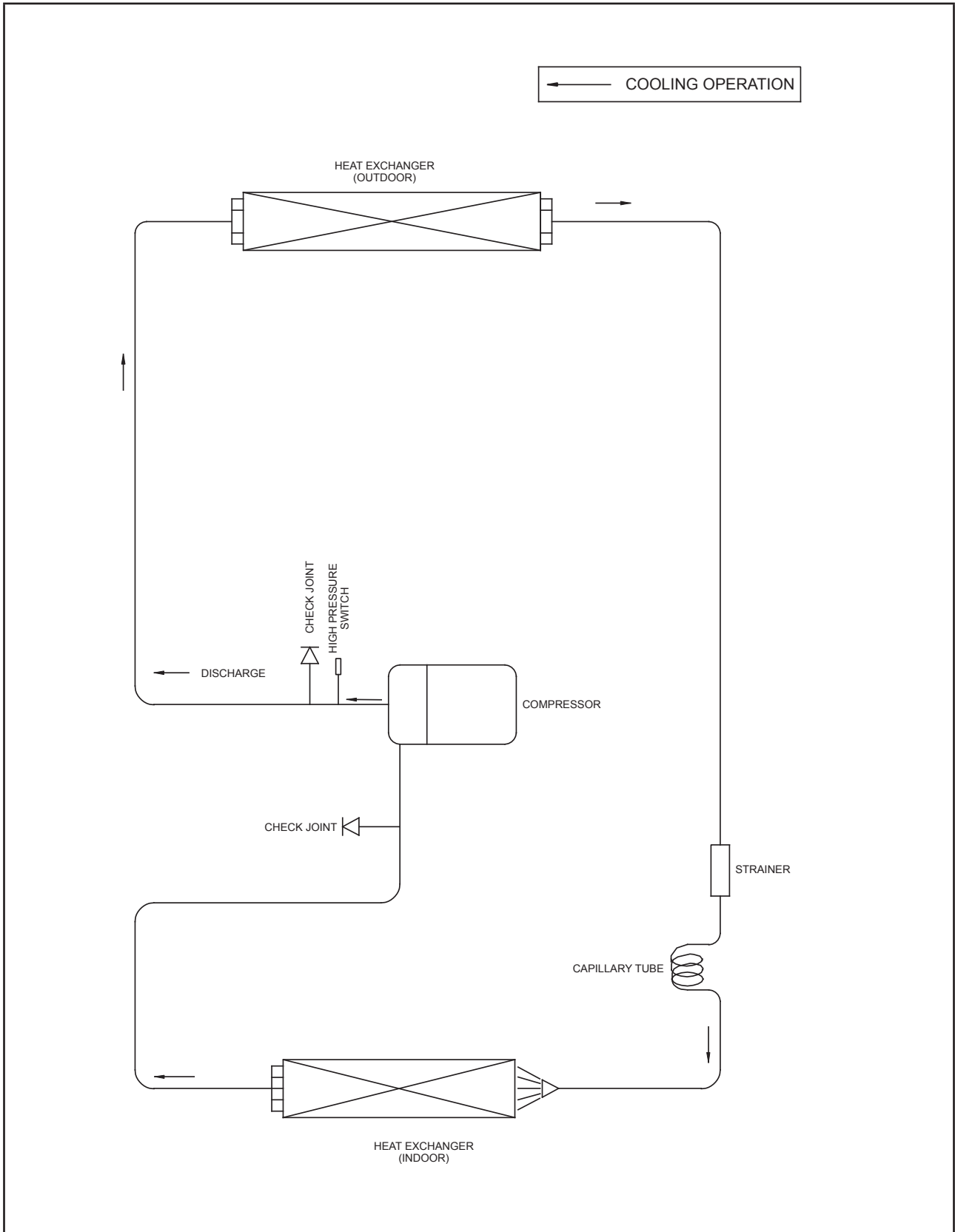

Model: UATP250/300AGXY1

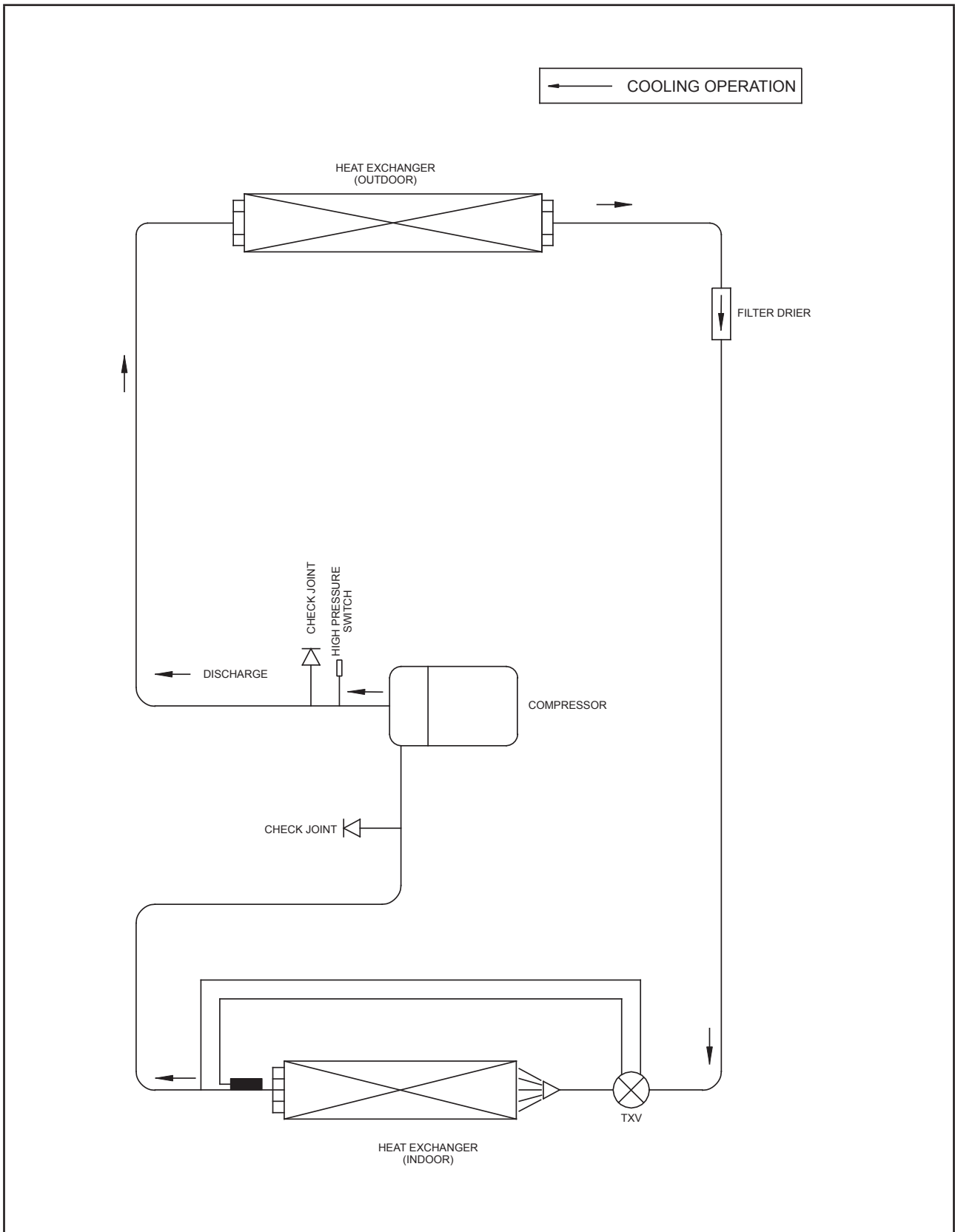

Model: UATP360/420AGXY1

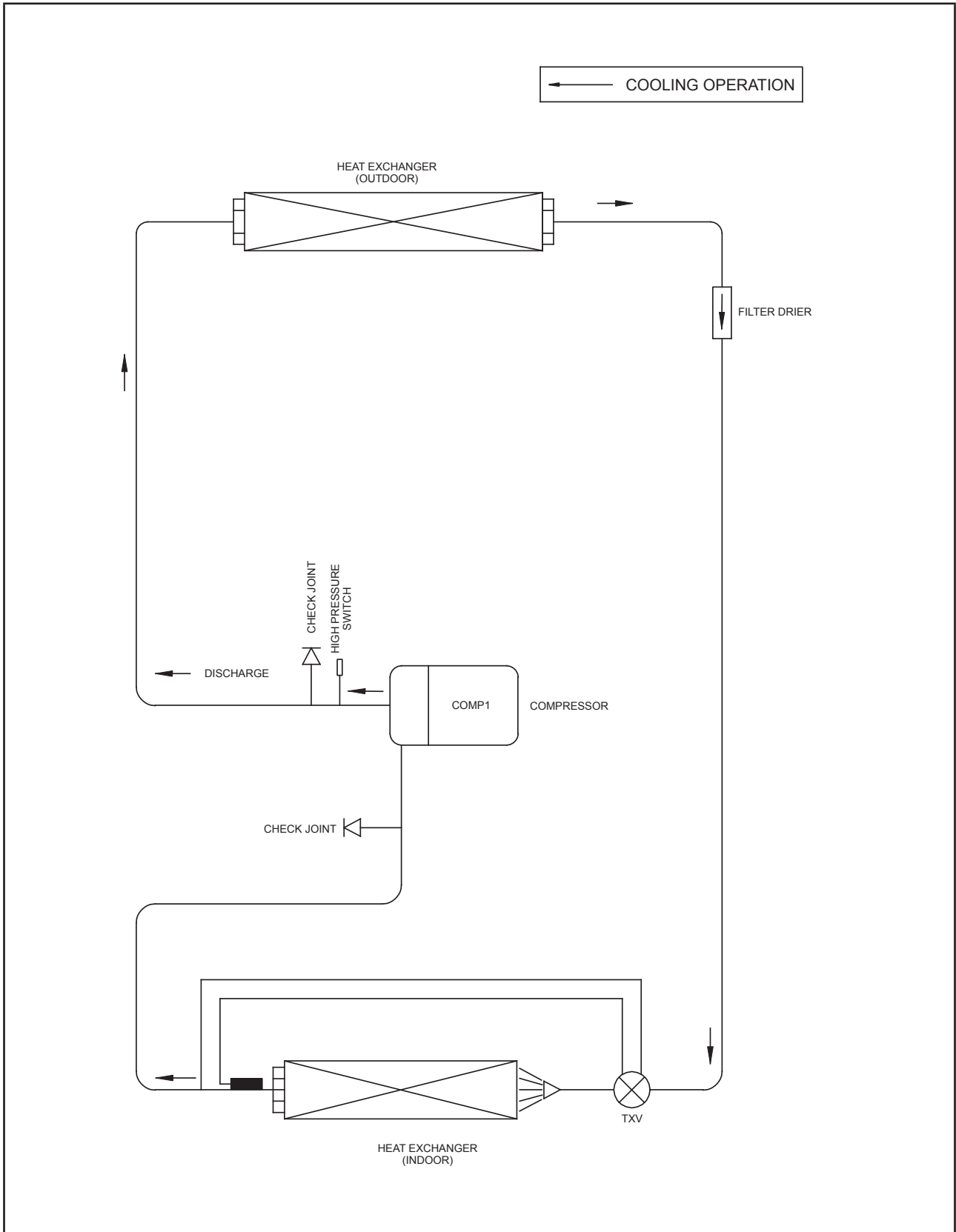

Model: UAT(Y)P60AGXY1

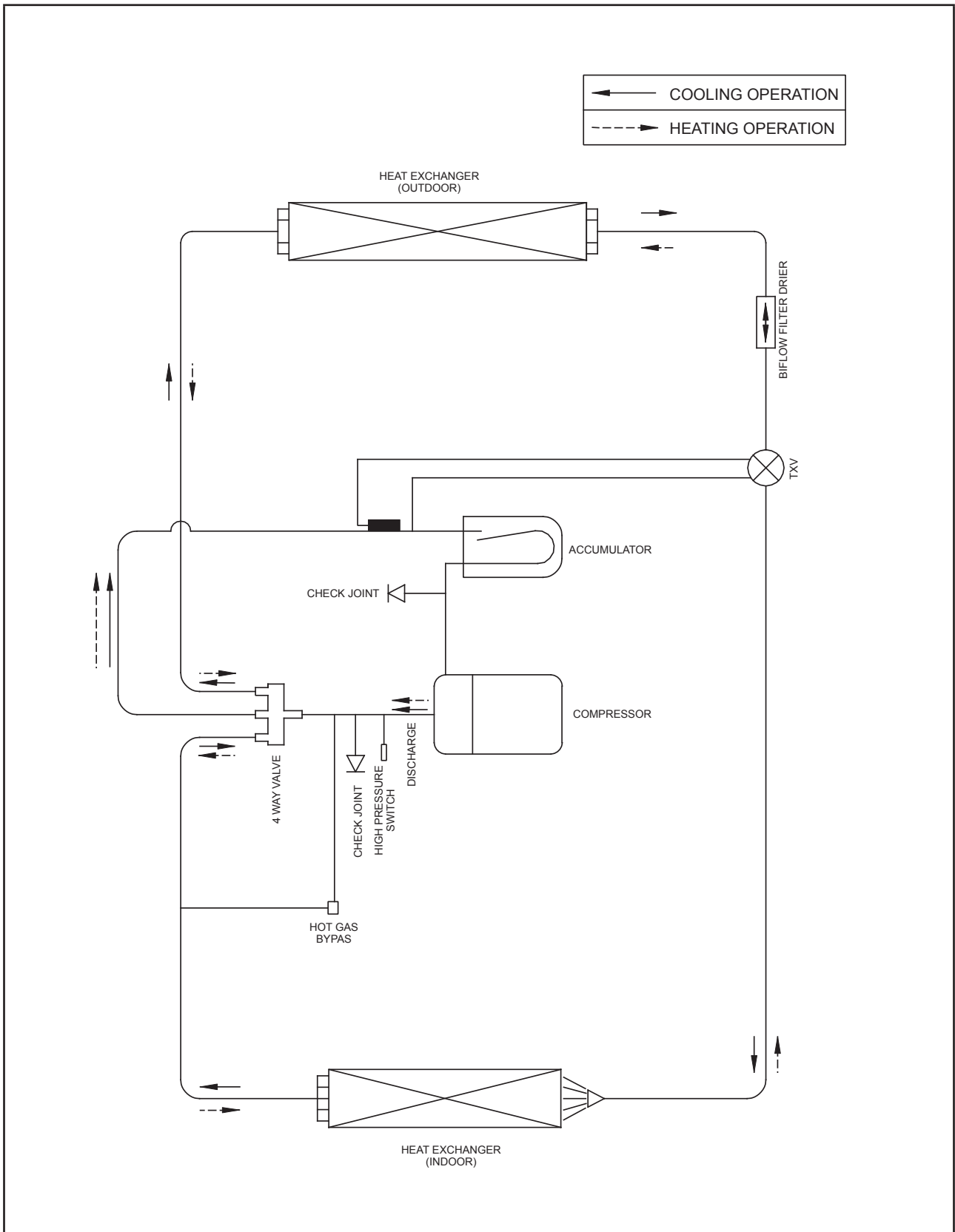

Model: UAT(Y)P80/100AGXY1

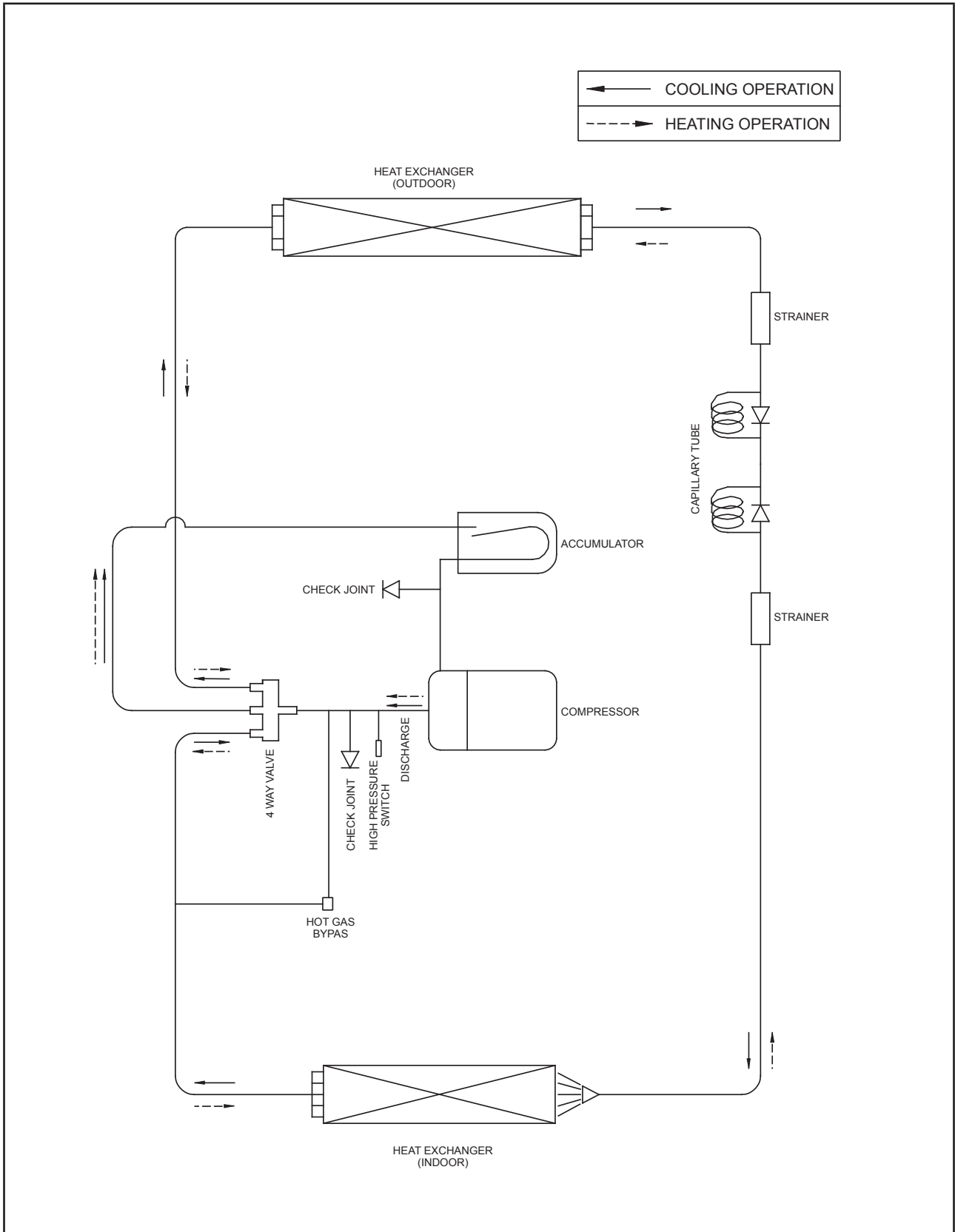

Model: UAT(Y)P80/100AGXY1

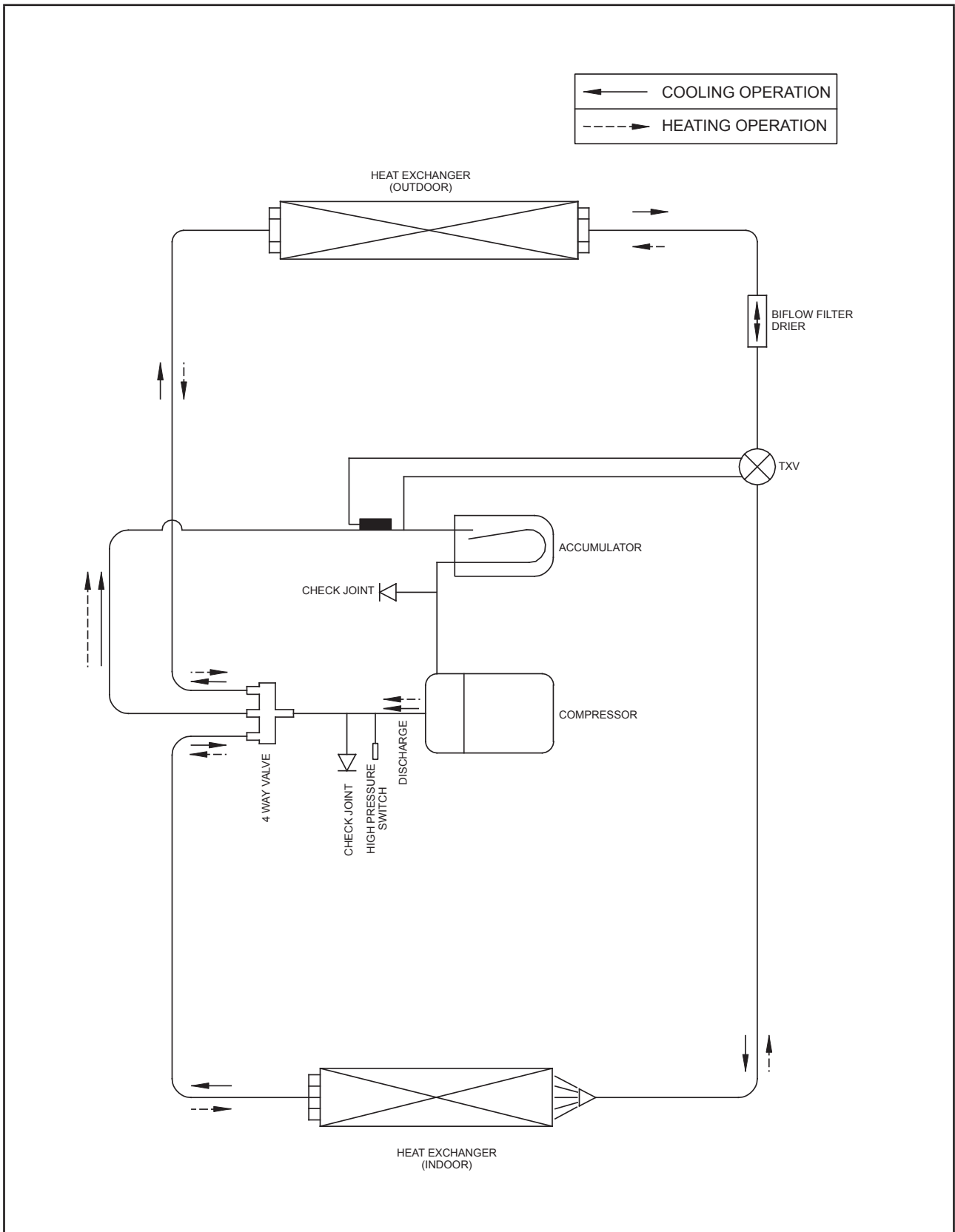

Model: UAT(Y)P120AGXY1

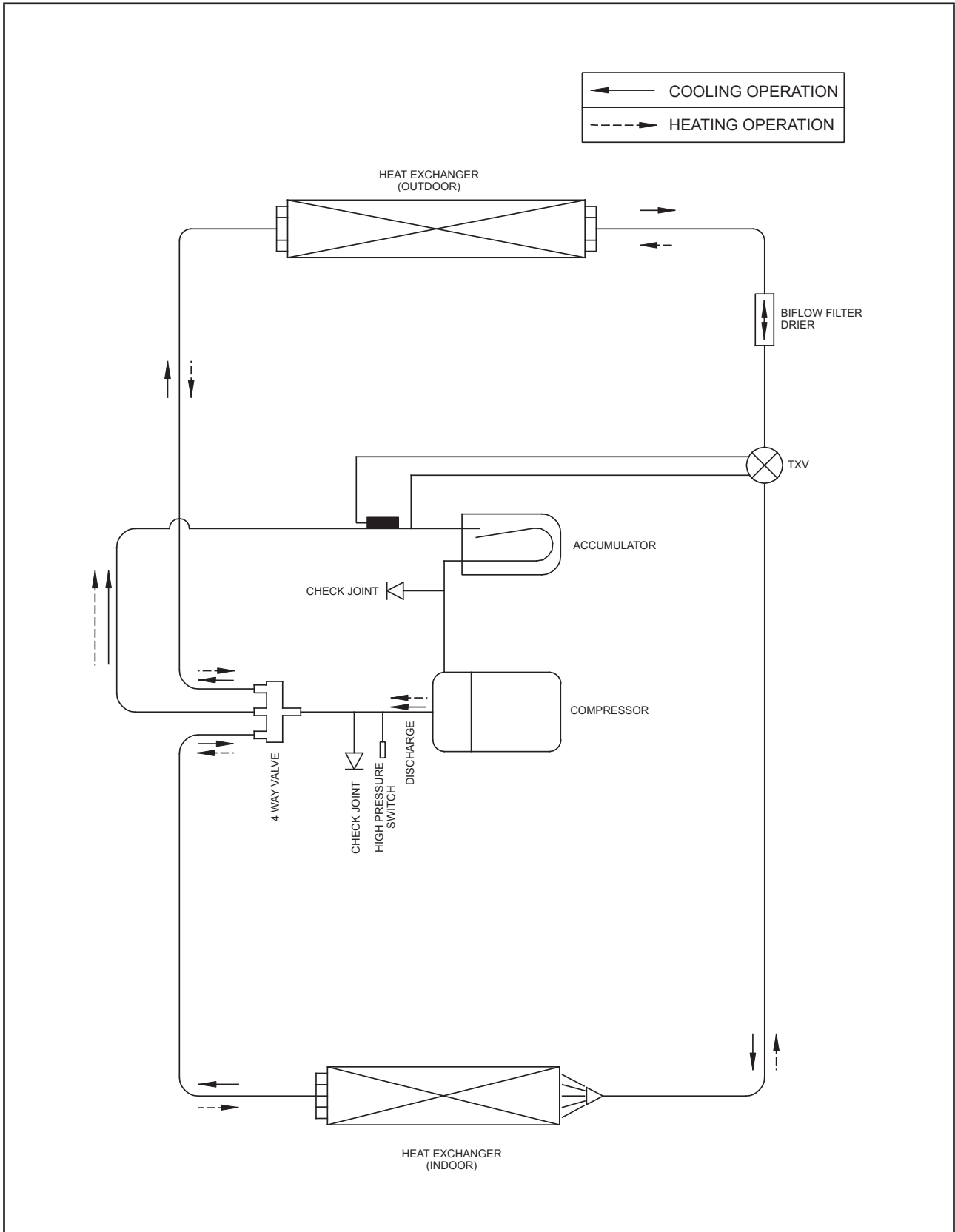

Model: UAT(Y)P150/200AGXY1

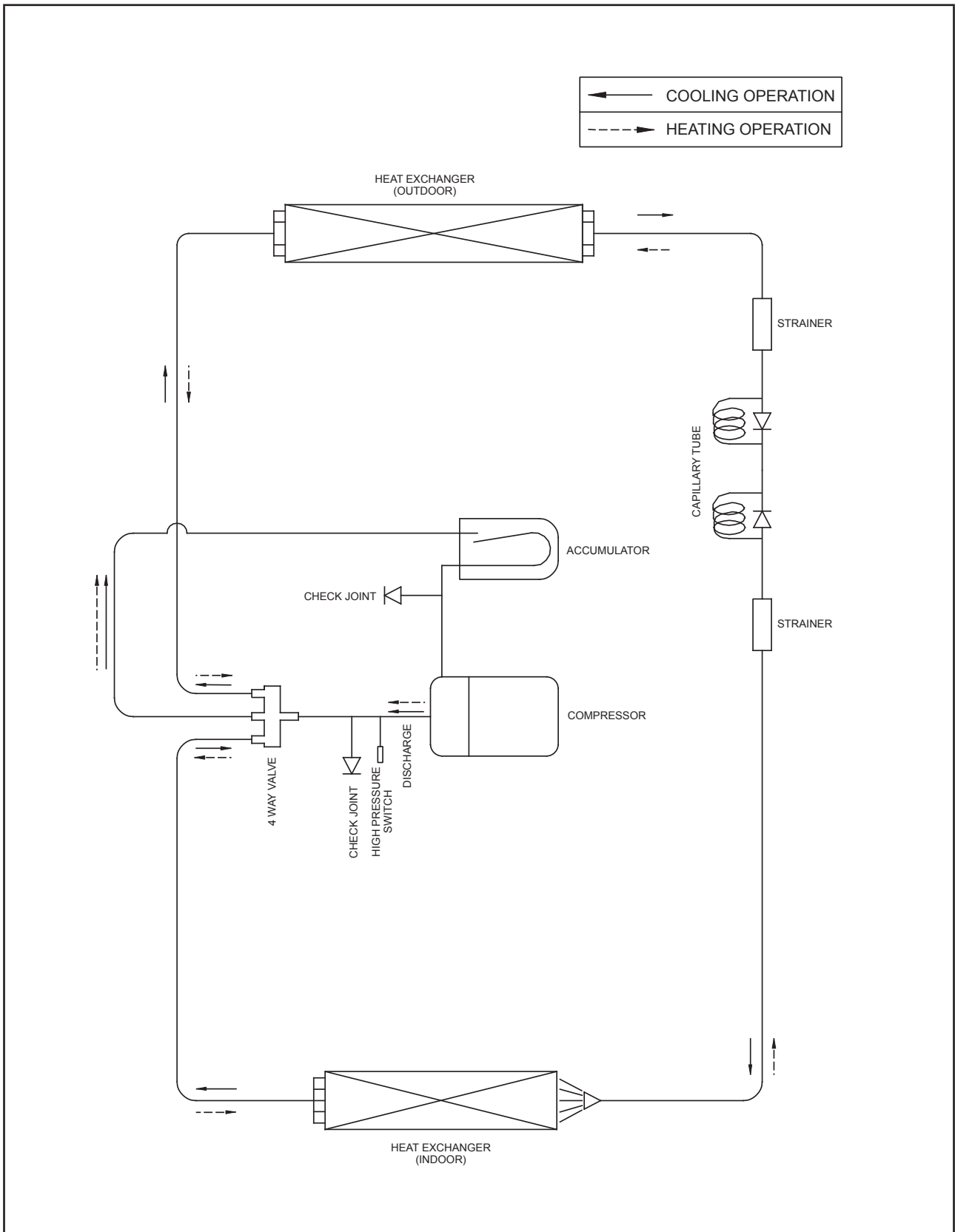

Model: UAT(Y)P150/200AGXY1

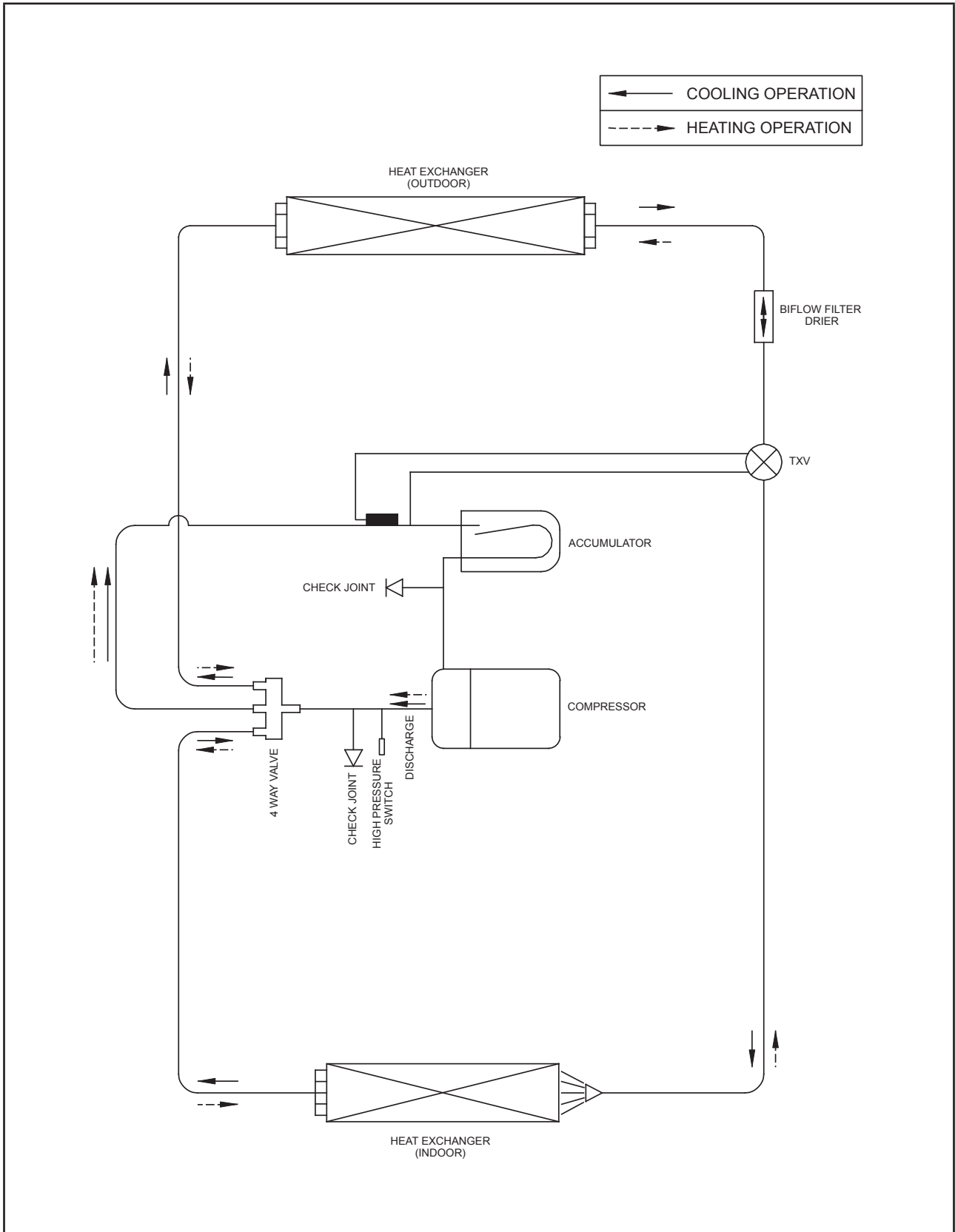

Model: UAT(Y)250/300AGXY1

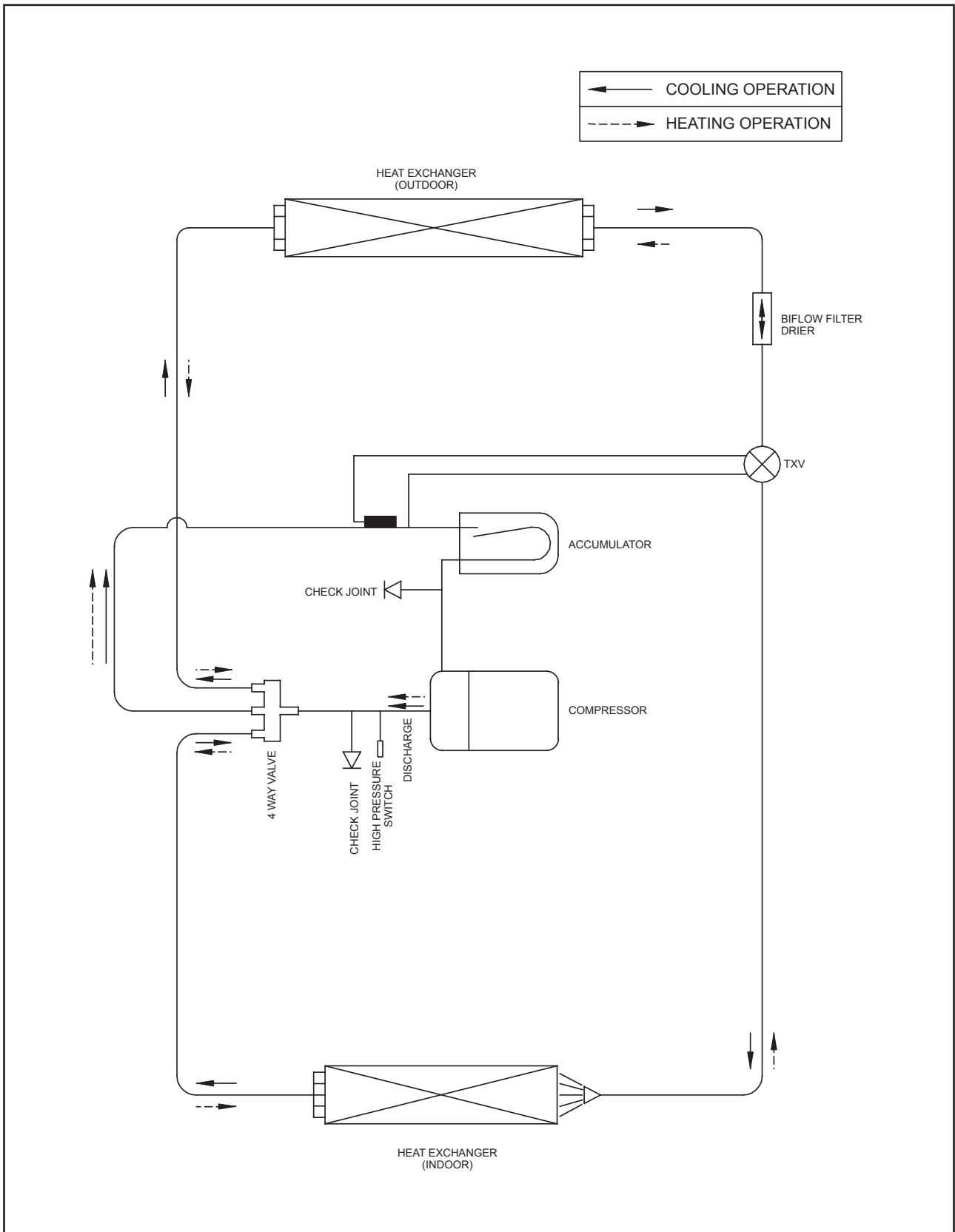

Model: UAT(Y)360/420AGXY1

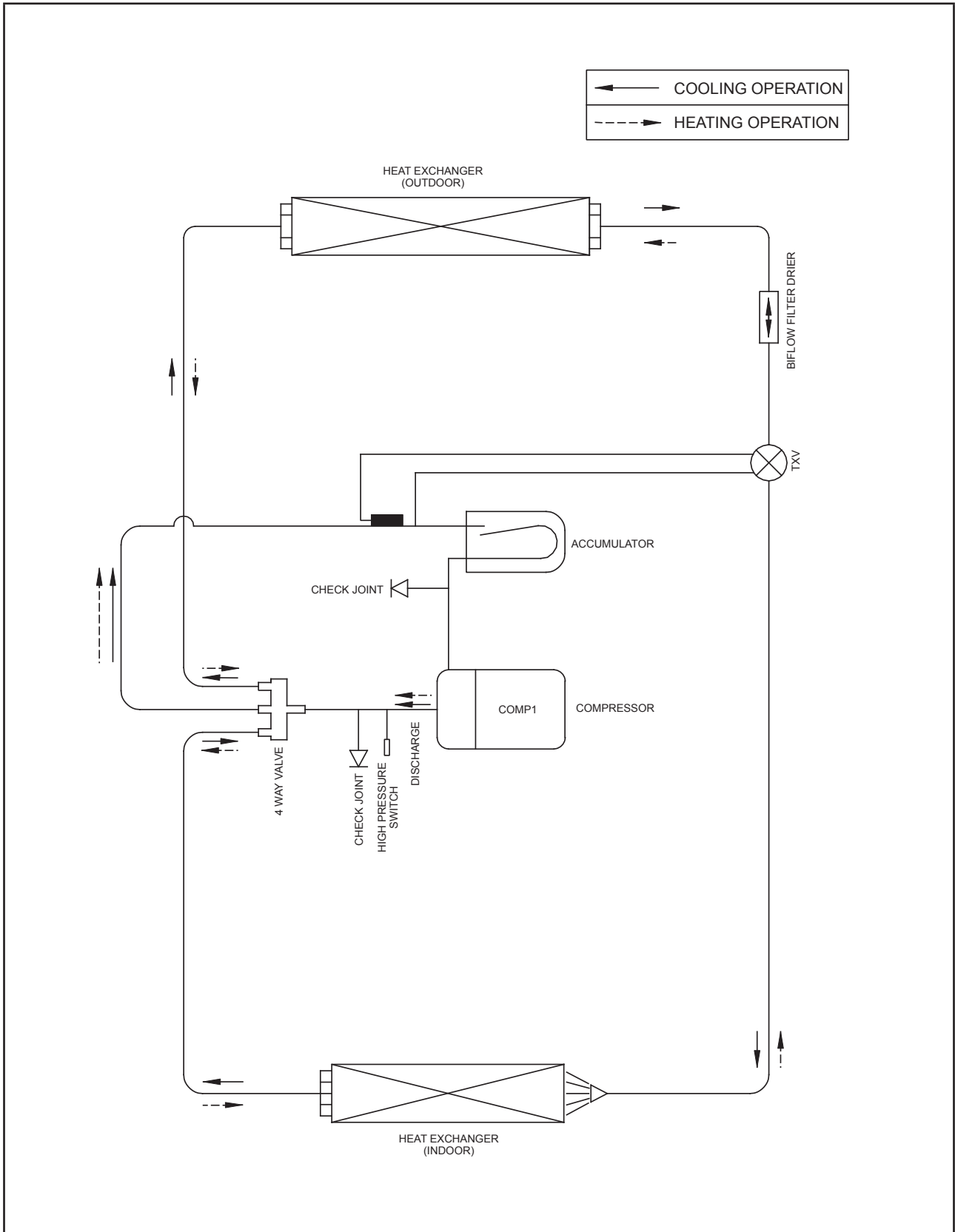

# Controllers

## SLM Wired Controller (Model: UAT(Y)P60/80/100/120AGXY1)

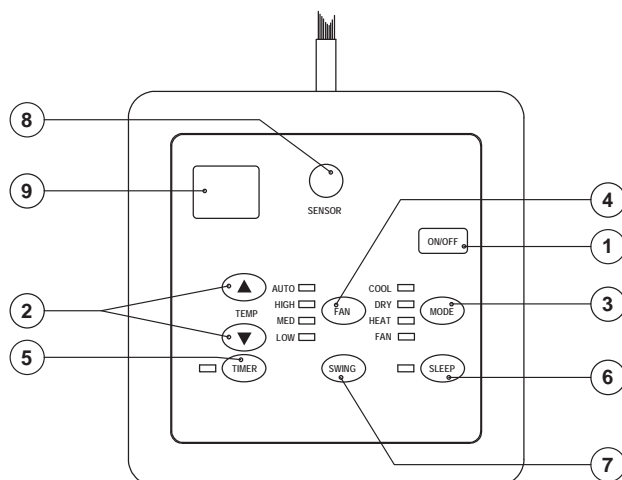

### SLM

1. **“ON/OFF” Switch**
  - Press to start the air conditioner unit.
  - Press again to stop the unit.
2. **Temperature Setting**
  - Set the desired room temperature.
  - Press button to increase or decrease the set temperature. Setting range are between 16°C to 30°C (60°F to 80°F).
3. **Operation Modes**
  - Press the “mode” button for select the type of operating mode.
    - Cooling Only :  
COOL, DRY, FAN
    - Heatpump :  
AUTO, COOL, DRY, HEAT, FAN  
(AUTO mode is represented by both COOL and HEAT LED light on)
4. **Fan Speed Selection**
  - Press the button until the desired fan speed is achieved.
5. **Timer**
  - Press the set button to select the switch timer of the air conditioner unit (the setting range is between 1 to 15 hours).
6. **“SLEEP” Mode**
  - Press button to activate the sleep function. This function can only be activated under “cool” or heating mode operation. When it is activated under “cool” mode operation, the set temperature will increase 0.5°C after 30 minutes, 1°C after 1 hour and 2°C after 2 hours. If it is activated under “HEAT” mode operation, the set temperature will be decreased 0.5°C after 30 minutes, 1°C after 1 hour and 2°C after 2 hours.
7. **Air Swing**
  - Press button to activate the automatic air swing function.
8. **Sensor**
  - Infra red sensor to receive signals from wireless controller.
9. **LED Display**
  - To display the set temperature (in °C) and timer delay setting (in hours).
10. **Transmission Source**
  - To transmit signals to the air conditioner.

Error	Seven Segments
Room Sensor missing/Short	E1 blinking
Indoor coil sensor missing/Short	E2 blinking
Outdoor coil sensor missing/Short	E3 blinking
Compressor overload	E4 blinking
Outdoor abnormal compressor overload trip or gas leak	E5 blinking

## Sequential Controller (Model: UAT(Y)P150/200/250/300/360/420AGXY1)

### Sequential Controller Functions

#### 1) Sequential Controller LCD Display

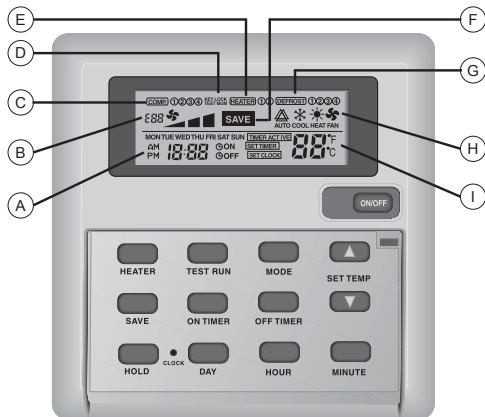

- A : Time display
- B : Error indication
- C : Compressor running display (up to 4 compressors)
- D : Key lock display
- E : Heater display (up to 2 heaters)
- F : Energy saving mode display
- G : Compressor defrost cycle display (up to 4 compressors)
- H : Operation mode display
- I : Temperature set display

#### 2) Operating Guide

##### a) ON/OFF Key

Press once to start the air conditioning unit.

Press again to stop the unit.

The operation lamp next to the key lights up and goes off respectively when the unit is running or not running.

Caution : In the case when the ON/OFF key is pressed immediately after the operation is stopped, the unit will not restart until 3 minutes later to protect the compressor.

##### b) Selecting Operation Mode

Press the MODE key to select the type of operating mode. Consecutive press of the key switches the operation over "COOL", "HEAT", "AUTO" and "FAN"





##### c) Save Mode

Press the SAVE key to select the energy saving function. This option is only available for "COOL", "HEAT" and "AUTO" modes.

##### d) Auxiliary Electric Heater

If the "HEAT" mode provides insufficient heating to a room even at the highest temperature setting (30°C), press the HEATER key to activate the auxiliary electric heater. For models with two heaters, consecutive press of the key allows the selection of one or both heaters active.

##### e) Temperature Setting

To set the desired room temperature, press  or  to increase or decrease the set temperature in the range of 16°C to 30°C. Press both  and  simultaneously to toggle between °C and °F setting.

##### f) Time Setting

###### Real time Clock

Press the CLOCK key once to activate set clock mode.

Press again to disable set clock mode.

Under set clock mode, the time of the present day can be set by pressing the respective MINUTE, HOUR and DAY key.

7-days timer

Press the **ON TIMER** key to activate auto-ON timer mode. Under this mode, press the respective **MINUTE, HOUR** and **DAY** key to select the time of the week when the air-conditioning unit is to automatically start running. Press the **ON TIMER** key again to save the setting.

Press the **OFF TIMER** key to activate auto-OFF timer mode. Under this mode, press the respective **MINUTE, HOUR** and **DAY** key to select the time of the week when the air-conditioning unit is to automatically stop running. Press the **ON TIMER** key again to save the setting.

Then to activate the 7-days timer, press and hold the **TIMER ACTIVE** key until the word "TIMER ACTIVE" appears on the LCD screen. Repeat the same step to disable the 7-days timer.

**g) Other Function**Key Lock

Press the **MINUTE** key 3 times consecutively and fast to activate the key lock. A "KEY LOCK" symbol will appear on the LCD screen. At this point, only the ON/OFF key is valid.

To disable the key lock, again press the **MINUTE** key 3 times consecutively and fast.

Test run

Press the TEST key 2 times consecutively to test run the unit.

**3) Error Code**

When the system is on and an error occurs, the **ON/OFF** LED on the LCD panel will blink and an error code is shown. When the system is off and there is a thermistor error, the **ON/OFF** LED is off but the error code is still displayed. Each error code represents different message as below

Error code	Possible fault	Error code	Possible fault
E01	Require manual reset (possible causes)		
E02	Compressor 1 high temperature (overload)	E20	Indoor coil sensor 1 open
E03	Compressor 2 high temperature(overload)	E21	Indoor coil sensor 2 open
E06	Compressor 1 high pressure trip / contact open	E24	Outdoor coil sensor 1 short
E07	Compressor 2 high pressure trip / contact open	E25	Outdoor coil sensor 2 short
E10	Compressor 1 trip / low R-22 / outdoor abnormal	E28	Outdoor coil sensor 1 open
E11	Compressor 2 trip / low R-22 / outdoor abnormal	E29	Outdoor coil sensor 2 open
E14	Room sensor short	E32	Compressor 1 de-ice
E15	Room sensor open	E33	Compressor 2 de-ice
E16	Indoor coil sensor 1 short		
E17	Indoor coil sensor 2 short		

**4) Installation Of LCD Remote Controller****a) Accessories**

The following accessories are included. If any part is missing, contact your dealer immediately.

- 1 Remote controller
- 2 Wooden screw 4.1 x 16 (2 pieces)
- 3 Instruction manual

**b) Step-by-step guide**

- i) First, open up the casing of the LCD remote controller into its top and bottom case using a screwdriver. To do this, insert the screwdriver into the lower slot and slide it in the outward direction.
- ii) Fix the bottom case onto the wall with the 2 wooden screws provided. Then, insert the 4 connecting wires (from the main board) through the slot on the lower right.
- iii) Connect one end in each of the 4 wires to the terminal block behind the top case as shown below. The wire that goes into the "GND" terminal at the top case must be connected at the other end to the "GND" terminal at the main board. The same goes for the "+5V", "B" and "A" connection.
- iv) Fasten back the top and bottom case into place. Hook the two upper claws into their respective slots and snap the lower part shut.

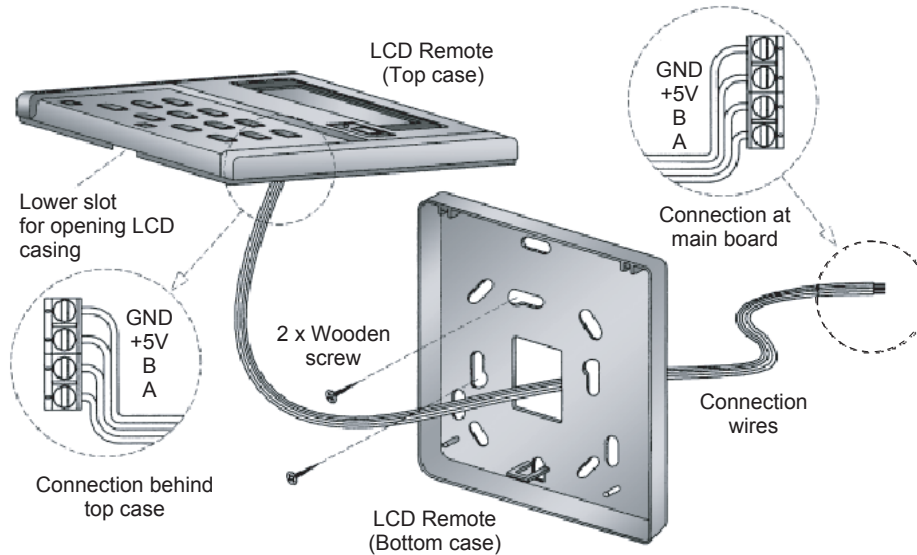

**5) Auto Random Restart**

When power is resumed, the unit will automatically restart and operate at the previous setting as before power failure occurred. (Remove jumper at JH/JP1 to cancel the auto random restart function. Please refer to wiring diagram for the location of JH/JP1 Jumper).

# Precaution & Installation

## Safety Precautions





Before installing the air conditioner unit, please read the following safety precautions carefully.

### **WARNING**

- Installation and maintenance should be performed by qualified persons who are familiar with local code and regulation, and experienced with this type of appliance.
  - All field wiring must be installed in accordance with the national wiring regulation.
  - Ensure that the rated voltage of the unit corresponds to that of the name plate before commencing wiring work.
  - According to the wiring diagram.
  - The unit must be GROUNDED to prevent possible hazard due to insulation failure.
  - All electrical wiring must not touch the refrigerant piping, compressor and any moving parts of the fan motors.
  - Confirm that the unit has been switched OFF before installing or servicing the unit.
- Before installing the air conditioner unit, please read the following safety precautions carefully.

### **CAUTION**

**Please take note of the following important points when installing**

- **Do not install the unit where leakage of flammable gas may occur**
  -  If gas leaks and accumulates around the unit, it may cause fire ignition.
- **Confirm drainage piping is connected properly**
  -  If the drainage piping is not connected perfectly, it may cause water leakage which will dampen the furniture.
- **Do not overcharge the unit**
  -  This unit is factory pre-charged. Over charge will cause over current or damage to the compressor.
- **Ensure that the unit panel is closed after service or installation.**
  -  Unsecured panel will cause unit to operate noisily.

## Installation

All series of air conditioners are designed for outdoor installations and are to be placed on a slab or rooftop. However, if the air conditioner is to be installed in a plant room, please contact your equipment supplier prior to installation for further advise.

Access to the compressors, control wiring, and fans for service and installation purpose must be provided. Please see item 1: Space Required Around Units for recommendations.

### 1. Space Required Around Units.

- (1) Care must be taken to prevent recirculation of air. To stabilize compressor and condensing pressure, it is recommended that wherever possible the condenser air inlet side should be faced away from prevailing winds. Please see diagrams below.
- (2) For rooftop installation, the type of mounting base depends on the construction of the roof. A built-up roof may not support the weight of the unit. Hence, it may be necessary to support the unit by adding structural members below it.
- (3) The units are equipped with hoisting hangers for rigging and hoisting of the unit. Please see item 3: Lifting method for further information.  
The hoisting plates are located on the top of the unit. When hoisting the unit with a crane, spreader bars must be used to prevent damage to side panels by the supporting cables.

**UAT(Y)P60/80/100/120AGXY1**

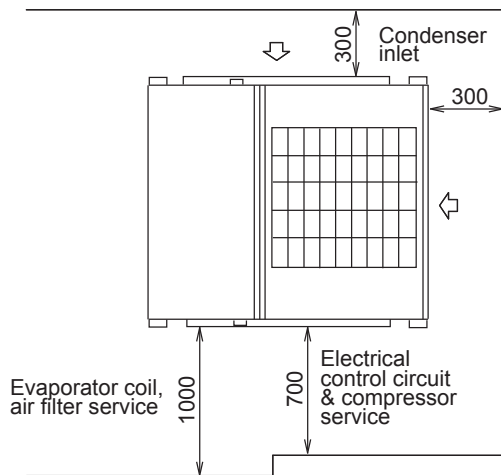

(unit : mm)

**UAT(Y)P150/200AGXY1**

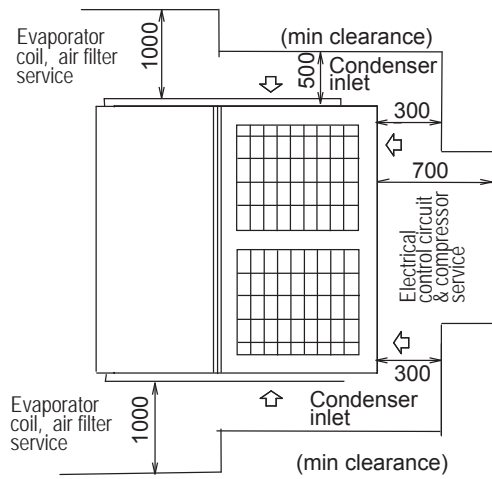

(unit : mm)

**UAT(Y)P250/300AGXY1**

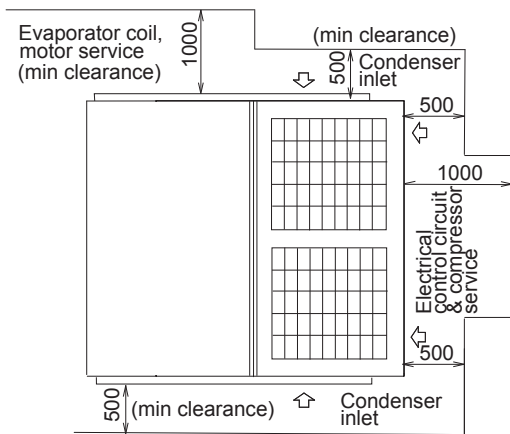

(unit : mm)

**UAT(Y)P360/420AGXY1**

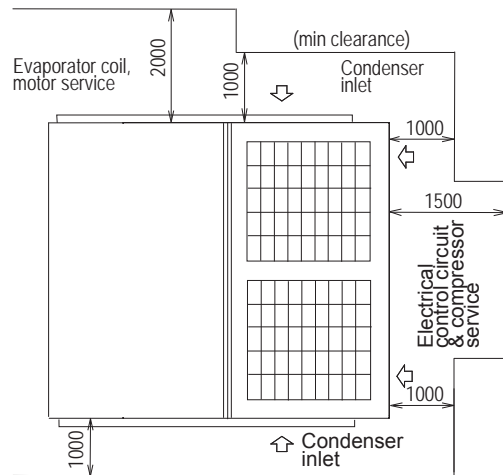

(unit : mm)

## 2. Duct Construction.

- (1) Series MRT side flow units are equipped with horizontal supply and return air openings. Duct connection to the unit should be made with duct flanges and secured directly to the air openings with flexible duct connectors to avoid normal noise transmission.
- (2) For vertical air supply, a field supply plenum should be used. The figure shows the recommended method for duct connection.
- (3) To prevent air leakage, all duct seams should be taped. Duct runs in air spaces that are not air-conditioned must be insulated and provided with a vapor barrier. Ducts exposed outdoors must be weather proofed. For quiet operation, we recommend that the insulation on the supply duct be placed inside, lining the duct.
- (4) Where ducts from outdoors enter a building, the duct openings in the building should be sealed with weather stripping to prevent rain, dirt, sand, etc. from entering the building.
- (5) Correctly sized filters must be fitted. There is no provision within the unit for the placement of filter. However, the filters may be installed in the return air chamber.
- (6) Duct earth wiring must be connected. Please refer to the section "Outlines and dimensions" for the correct position.

Duct connection with a vertical air plenum at MRT side flow unit

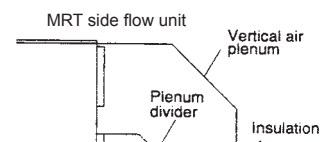

### Optional Feature (Down Flow)\*

Series MRT down flow units are equipped with vertical supply and return air openings. Duct connection to the unit should be made with duct flanges to avoid normal noise transmission.

When connecting duct earth wiring for down flow configuration, we must use accessory screw attached on the control box cover.

\* Site modification required. Please refer to item 6: OPTIONAL FEATURES for details.

Duct connection at MRT down flow unit

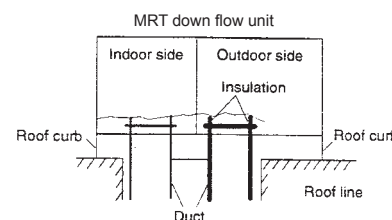

## 3. Lifting Method.

When the unit is to be lifted and moved, attach ropes to the hoisting hangers (4 pieces) provided on the top corners of the unit.

When the unit is lifted, its center of gravity tends to shift the unit to one side. Imbalance such as that in the figure should be attained. The angles at which the ropes suspend the unit should be at least 60° at the compressor end and at least 45° at the condenser end.

Care should be taken to avoid contact with the unit while it is being lifted.

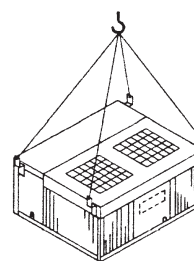

Hook (as directly aligned over the center of gravity as possible)

## 4. Drain Piping.

- (1) The condensate drain fitting (R1) is provided. The drain pipe can be led out at the right or left side. Please see Chapter 10: Outlines & Dimensions for further details.
- (2) The drain pipe must be provided with a trap on the outside of the unit and also installed at an incline for proper drainage, as shown below.
- (3) To prevent condensate formation and leakage, provide the drain pipe with insulation to safeguard against sweating.
- (4) Upon completion of the piping work, check that there is no leakage and that the water drains off properly.

The drain piping should have a drain trap.

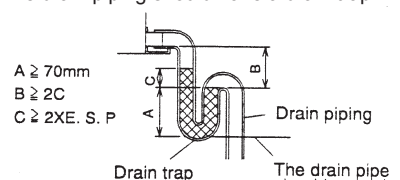

Note: ESP = External Static Pressure  
Drain trap for condensate

### 5. Refrigerant Charge

An additional charge is unnecessary.

The table below shows the amount of the charge when the unit is shipped from the factory.

	UATP60AGXY1	UATP80AGXY1	UATP100AGXY1	UATP120AGXY1	UATP150AGXY1
Refrigerant charge per circuit (kg)	4.6	4.6	5.9	5.6	2 x 3.9
	UATP200AGXY1	UATP250AGXY1	UATP300AGXY1	UATP360AGXY1	UATP420AGXY1
Refrigerant charge per circuit (kg)	2 x 4.2	2 x 9.6	2 x 10.4	14.5 , 18.0	2 x 18.0
	UATYP60AGXY1	UATYP80AGXY1	UATYP100AGXY1	UATYP120AGXY1	UATYP150AGXY1
Refrigerant charge per circuit (kg)	4.3	5.2	6.0	6.0	2 x 5.0
	UATYP200AGXY1	UATYP250AGXY1	UATYP300AGXY1	UATYP360AGXY1	UATYP420AGXY1
Refrigerant charge per circuit (kg)	2 x 5.8	2 x 9.4	2 x 9.6	13.5 , 16	2 x 16

### 6. Optional Features (Down Flow) - Site Modification Required.

#### Reconstruction Method. (From Side Flow To Down Flow)

#### (For UAT(Y)P80/100/120/150/200AGXY1 Only)

Series MRT side flow units are able to be modified to down flow in the field with the help of additional accessory items.

The following diagrams show the necessary steps to reconstruct the unit from side flow to down flow.

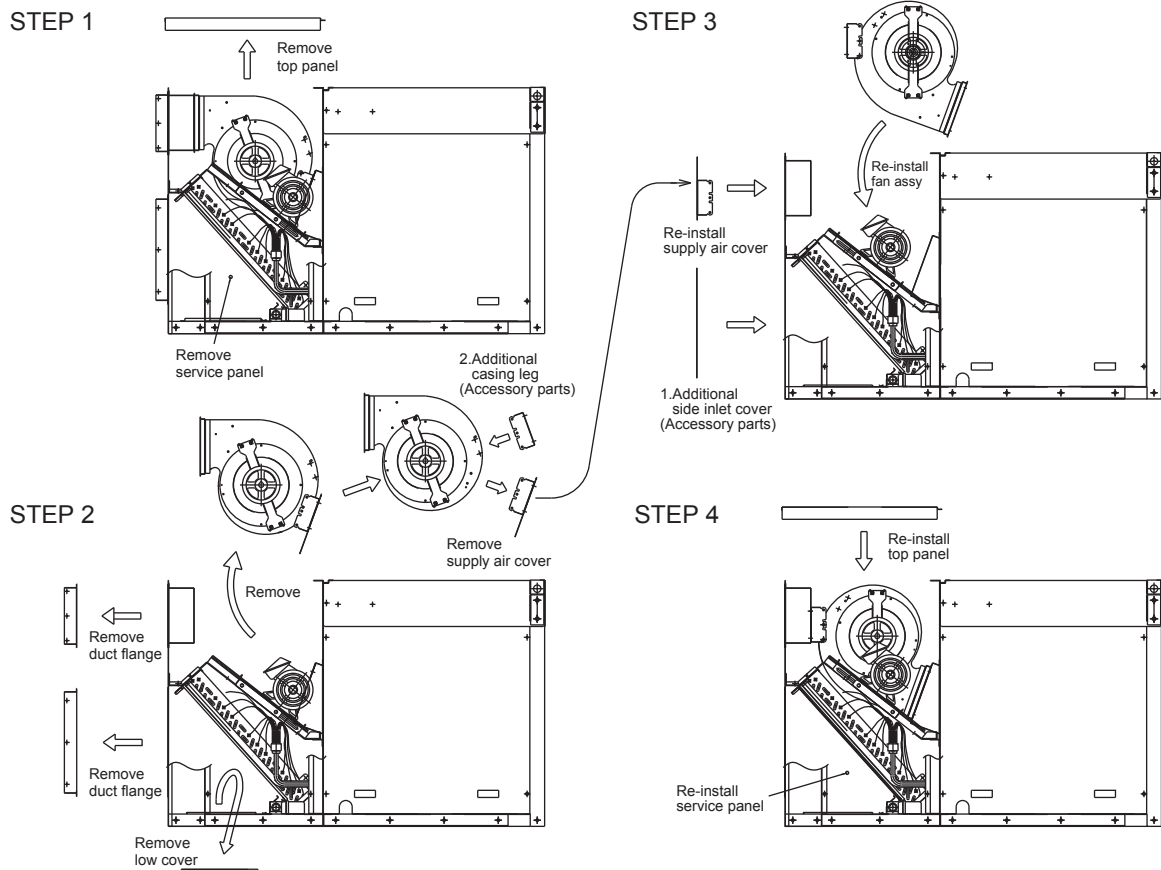

## 7. Special Precautions When Dealing With Refrigerant R407C Unit

### (1) What Is New Refrigerant R407C?

R407C is a zeotropic refrigerant mixture which has Zero Ozone Depletion Potential (ODP = 0) and thus, conforms to the Montreal Protocol regulation. It requires Polyol-ester (POE) oil for its compressor's lubricant. Its refrigerant capacity and performance are about the same as the refrigerant R22.

### (2) Components

Mixture of composition by weight: R32(23%), R125(25%), R134a(52%)

### (3) Characteristic

- R407C liquid and vapor components have different compositions when the fluid evaporates or condenses. Hence, when a leak occurs and only vapor leaks out, the composition of the refrigerant mixture left in the system will change and subsequently affect the system performance. DO NOT add new refrigerant to a leaked system. It is recommended that the system should be evacuated thoroughly before recharging with R407C.
- When refrigerant R407C is used, the composition will differ depending on whether it is in gaseous or liquid phase. Hence when charging R407C, ensure that only liquid is being withdrawn from the cylinder or can. This is to make certain that only original composition of R407C is being charged into the system.
- POE oil is used as a lubricant for R407C compressor, which is different from the mineral oil used for R22 compressor. Extra precaution must be taken to avoid exposing the R407C system to moist air.

### (4) Check List Before Installation/servicing

- Tubing  
Refrigerant R407C is more easily affected by dust or moisture compared with R22, make sure to temporarily cover the ends of the tubing prior to installation
- Compressor oil  
No additional charge of compressor oil is permitted.
- Refrigerant  
No other refrigerant other than R407C
- Tools  
Tools specifically for R407C only (must not be used for R22 or other refrigerant)
  - i) Gauge manifold and charging hose
  - ii) Gas leak detector
  - iii) Refrigerant cylinder/charging cylinder
  - iv) Vacuum pump c/w adapter
  - v) Flare tools
  - vi) Refrigerant recovery machine

### (5) Handling And Installation Guidelines

Like R22 systems, the handling and installation of R407C systems are closely similar. All precautionary measures; such as ensuring no moisture, no dirt or chips in the system, clean brazing using nitrogen, and thorough leak check and vacuuming are equally important requirements. However, due to the zeotropic nature of R407C and its hydroscopic POE oil, additional precautions must be taken to ensure optimum and trouble-free system operation.

- (a) Filter-dryer must be installed along the liquid line for all R407C air conditioners. This is to minimise the contamination of moisture and dirt in the refrigerant system. Filter-dryer must be of molecular sieve type. For a heat-pump system, install a two-way flow filter dryer along the liquid line.
- (b) During installation or servicing, avoid prolonged exposure of the internal part of the refrigerant system to moist air. Residual POE oil in the piping and components can absorb moisture from the air.
- (c) Ensure that the compressor is not exposed to open air for more than the recommended time specified by its manufacturer (typically less than 10 minutes). Remove the seal-plugs only when the compressor is about to be brazed.
- (d) The system should be thoroughly vacuumed to 1.0 Pa (-700mmHg) or lower. This vacuuming level is more stringent than R22 system so as to ensure no incompressible gas and moisture in the system.

- (e) When charging R407C, ensure that only liquid is being withdrawn from the cylinder or can. This is to ensure that only the original composition of R407C is being delivered into the system. The liquid composition can be different from the vapor composition.

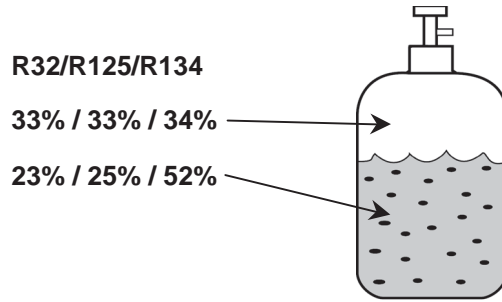

Composition of R407C in vapour phase is different from liquid phase.

- (f) Normally, the R407C cylinder or can is being equipped with a dip-pipe for liquid withdrawal. However, if the dip -pipe is not available, invert the cylinder or can so as to withdraw liquid from the valve at the bottom.

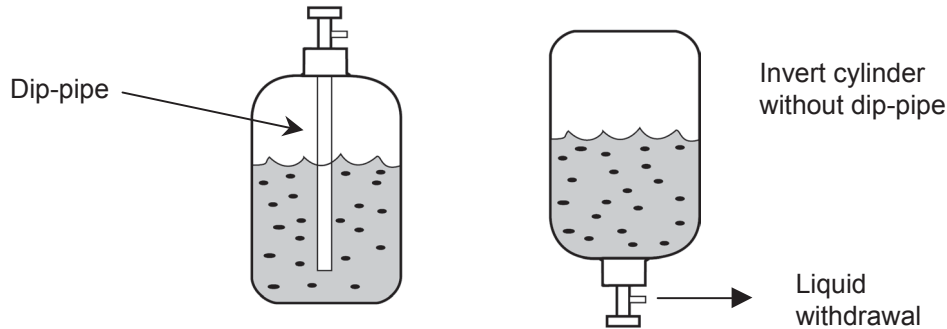

- (g) When servicing leaks, the top-up method, commonly practiced for R22 system, is not recommended for R407C systems. Unlike R22 where the refrigerant is of a single component, the composition of R407C (which is made-up of three different components) may have changed during the leak. Consequently, atop-up may not ensure that the R407C in the system is of the original composition. This composition shift may adversely affect the system performance. It is recommended that the system be evacuated thoroughly before recharging with R407C.

## 8. Electric Wiring

### Construct The Earth Connection.

All electrical work must be carried out by a suitable qualified electrical trades-person and in accordance with local supply authority requirements and associated regulators.

The unit is to be wired directly from an electrical distribution board either by a circuit breaker (preferred) or HRC fuse.

Fix power source wiring to control box by using buffer bushing for sensible force (PG connection or the like). Connect control wiring to control terminal block through the knockout hole of control box using ordinary bushing.

NOTE : Earth wiring must be connected.

**Arrangement such as terminal block in control box.**

**Method For Connecting Electric Wire**

Please carry out the wiring after consulting with local electric power company on local regulations.

(I) The entire wiring diagram of unit.

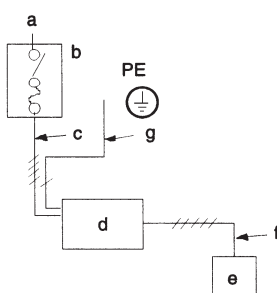

a.	Power supply
b.	Main switch/fuse (field supply)
c.	Power supply wiring for unit
d.	Unit
e.	Remote controller
f.	Connection wiring for unit / remote controller (no polarity)
g.	Earth

(II) Electrical wiring

Remove the panel on the right side M(4)RT060~120A/AR or the rear side M(4)RT150~420A/AR of the unit and connect the units power supply wiring to the proper terminals in the control box.

Connect the wires by following the wiring diagram. Mis-connection will damage the controller.

(III) Wiring example and selection of earth leakage breaker

380~415V, 50Hz, 3Ø

Model	Power cable	Breaker capacity	Over current protection switch	Earth cable
UAT(Y)P60AGXY1	8 mm <sup>2</sup>	40A	40A	8 mm <sup>2</sup> over
UATYP80AGXY1	14 mm <sup>2</sup>	50A	50A	14 mm <sup>2</sup> over
UATYP100AGXY1	14 mm <sup>2</sup>	50A	50A	14 mm <sup>2</sup> over
UATYP120AGXY1	14 mm <sup>2</sup>	50A	50A	14 mm <sup>2</sup> over
UATYP150AGXY1	22 mm <sup>2</sup>	100A	100A	22 mm <sup>2</sup> over
UATYP200AGXY1	22 mm <sup>2</sup>	100A	100A	22 mm <sup>2</sup> over
UATYP250AGXY1	38 mm <sup>2</sup>	125A	125A	38 mm <sup>2</sup> over
UATYP300AGXY1	38 mm <sup>2</sup>	125A	125A	38 mm <sup>2</sup> over
UATYP360AGXY1	38 mm <sup>2</sup>	125A	125A	22 mm <sup>2</sup> over
UATYP420AGXY1	38 mm <sup>2</sup>	125A	125A	22 mm <sup>2</sup> over

The grounding wire must be of the same diameter as the power cable wires. The table above is an example.

The selection of other capacities should be determined in accordance with the relevant local standards, in the country of installation.

Note:

All electrical wiring must comply with local electrical authority regulations.

### Control Module Of Unit UATP60AGXY1

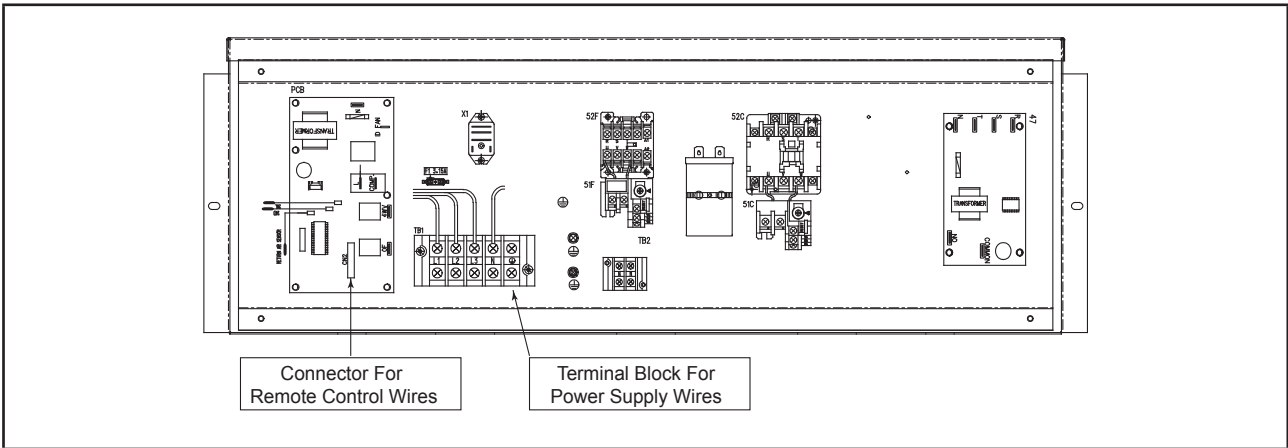

### Control Module Of Unit UATP80/100AGXY1

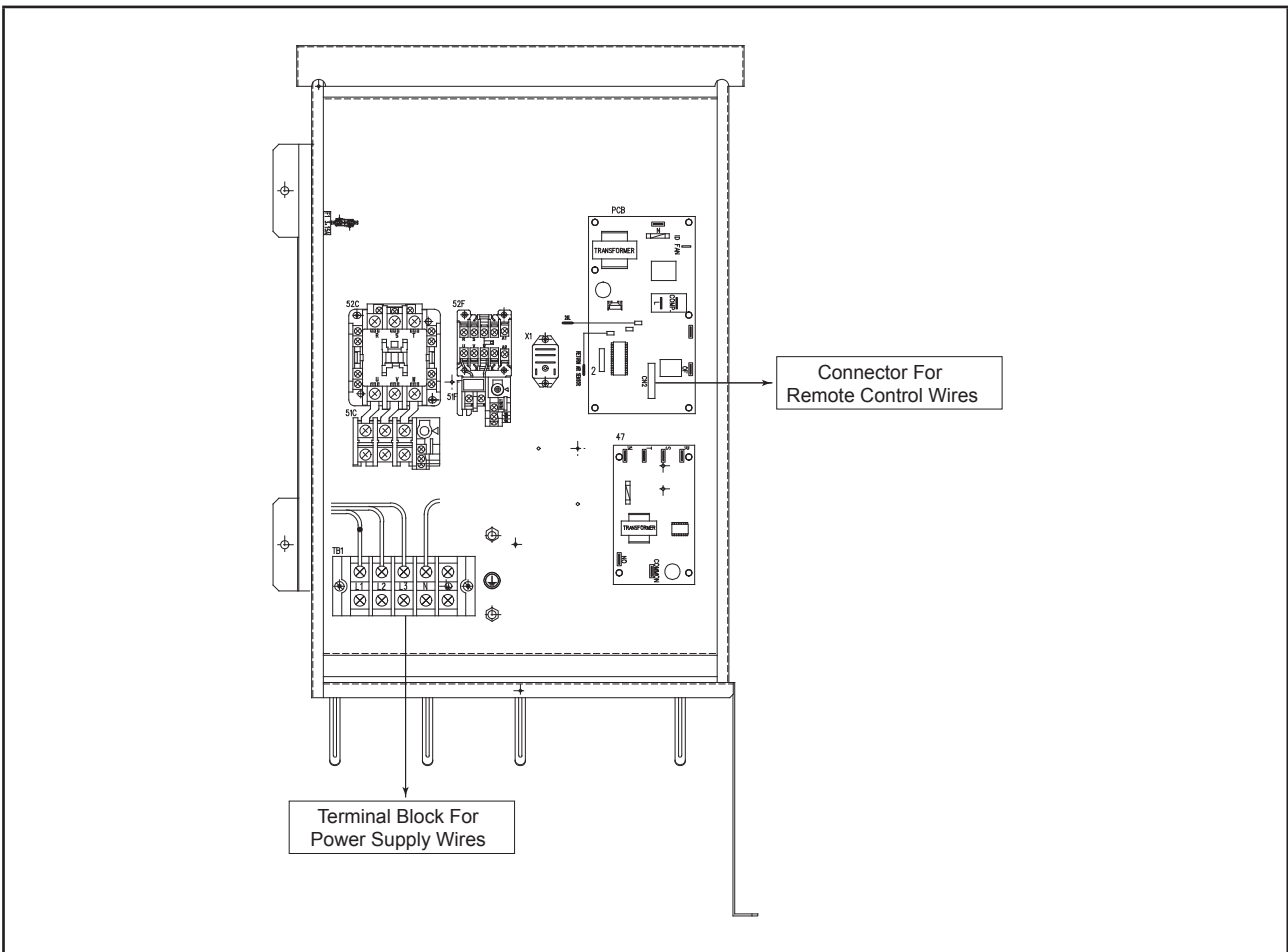

**Control Module Of Unit UATP120AGXY1**

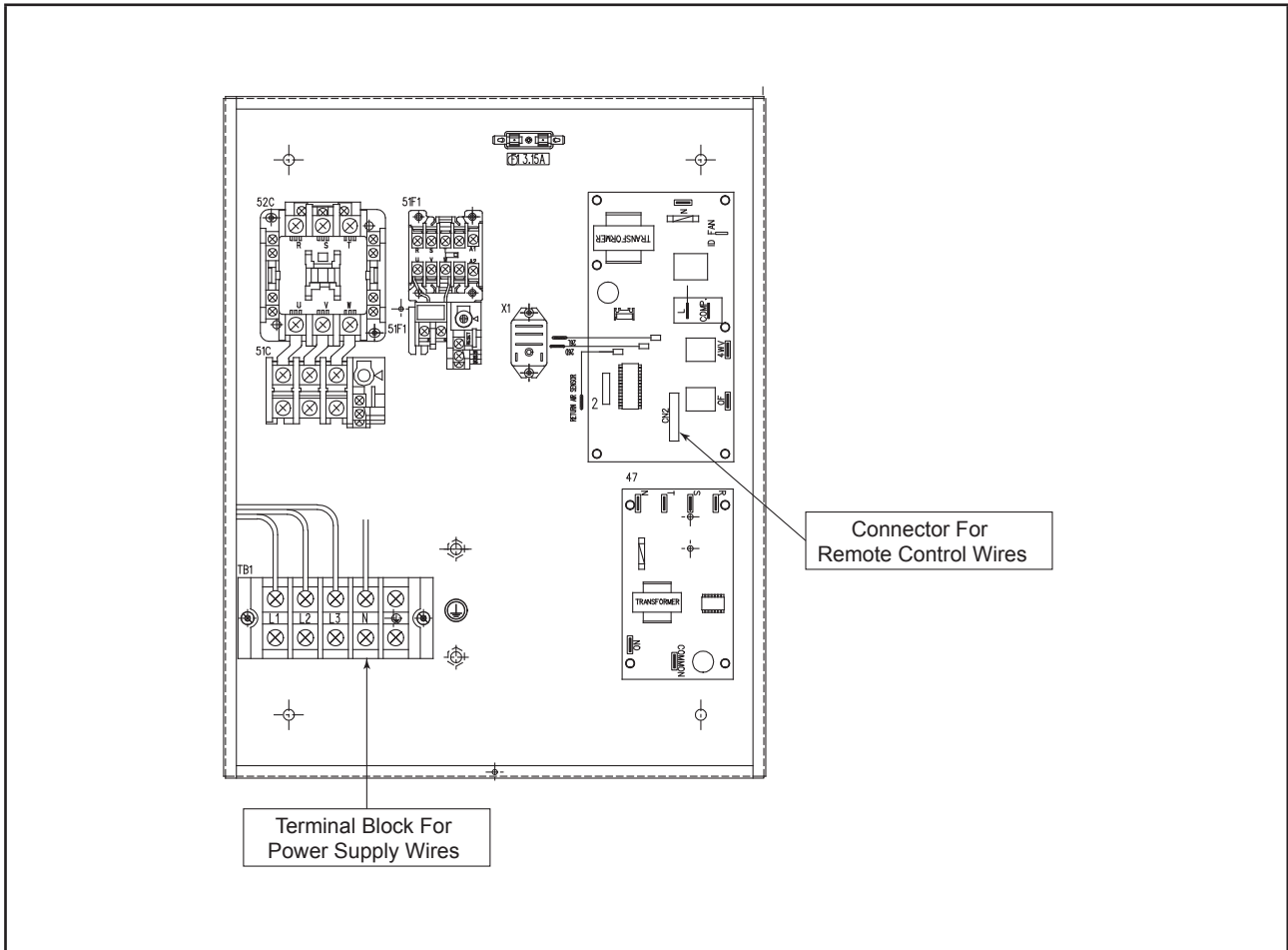

**Control Module Of Unit UATP150/200AGXY1**

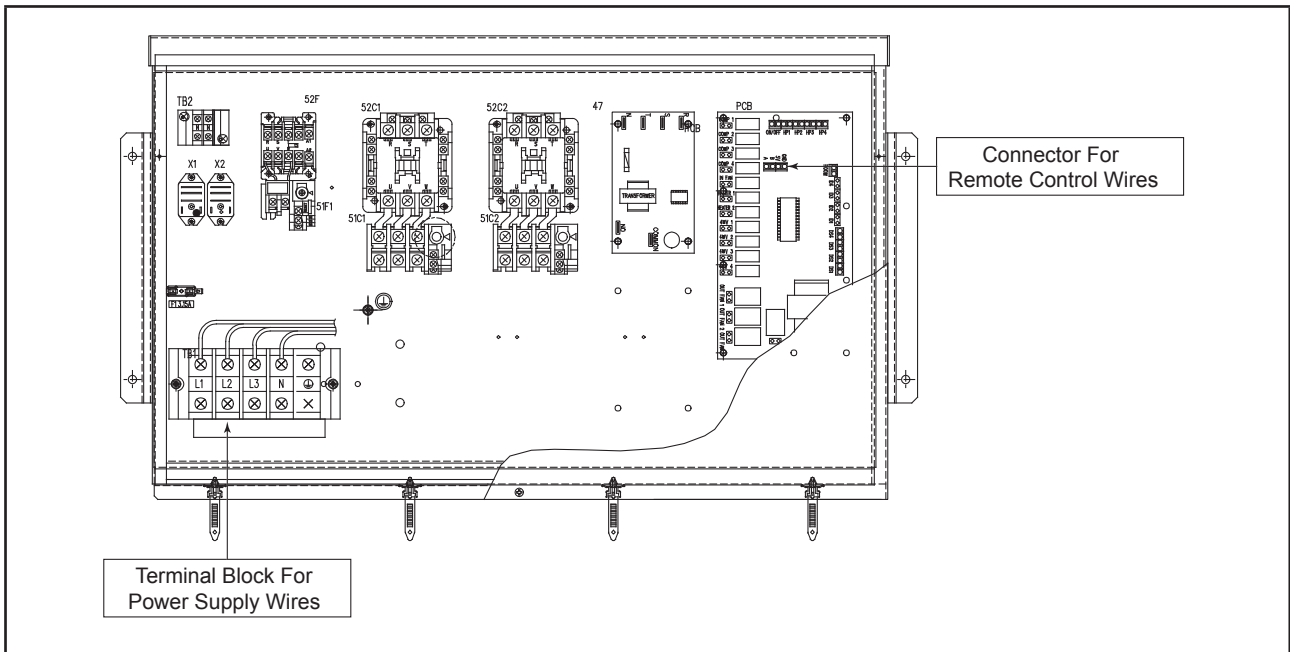

### Control Module Of Unit UATP250/300AGXY1

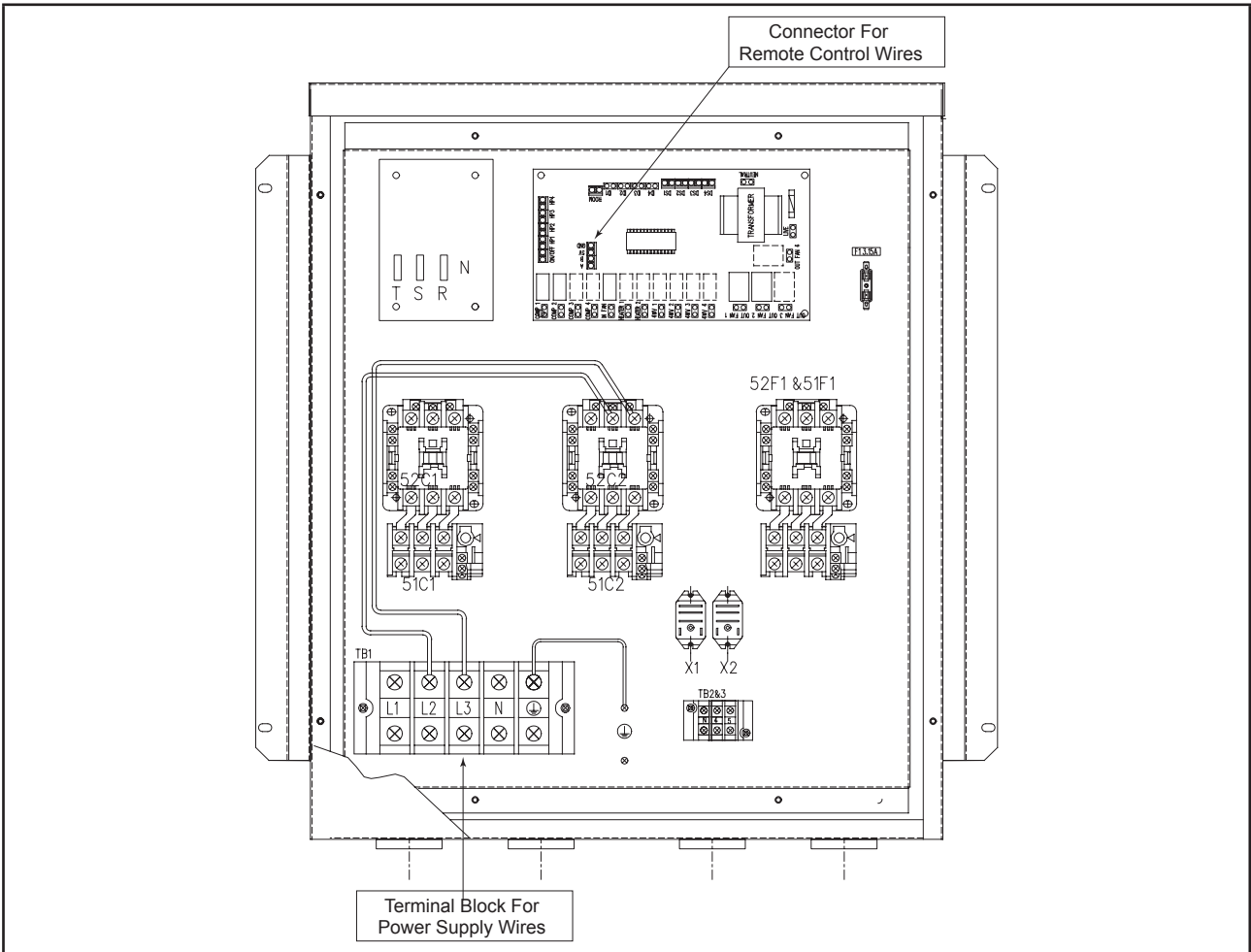

### Control Module Of Unit UATYP60AGXY1

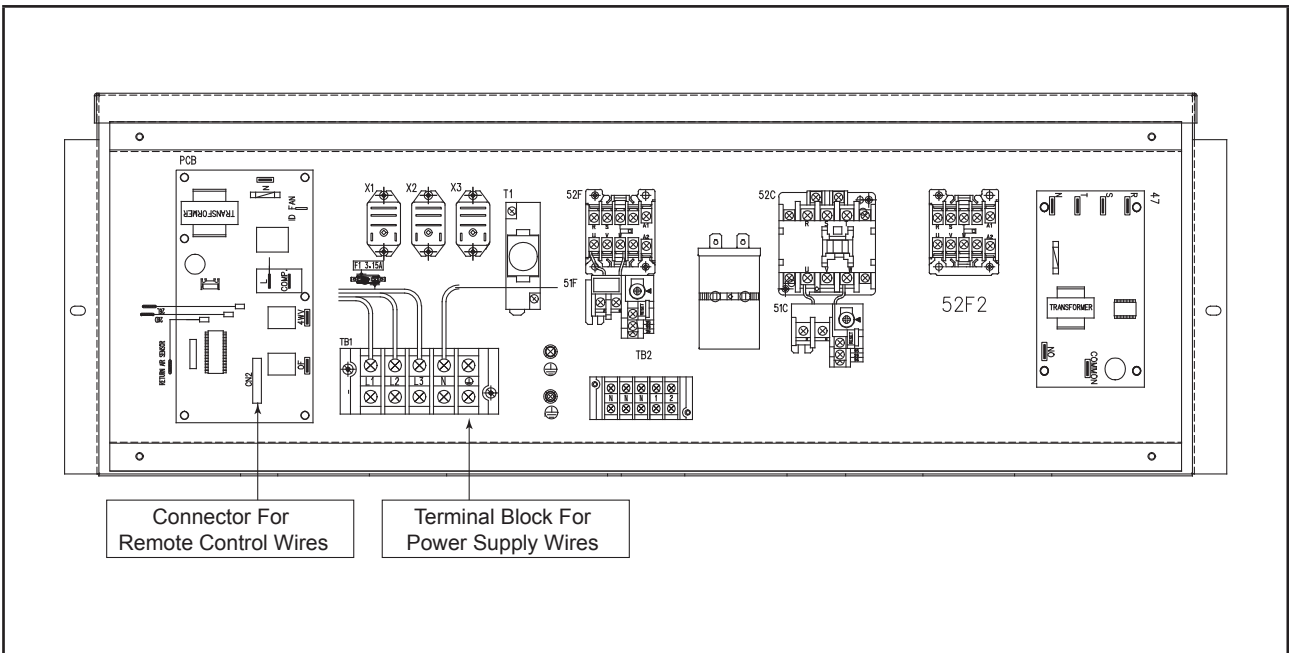

Control Module Of Unit UATYP80/100AGXY1

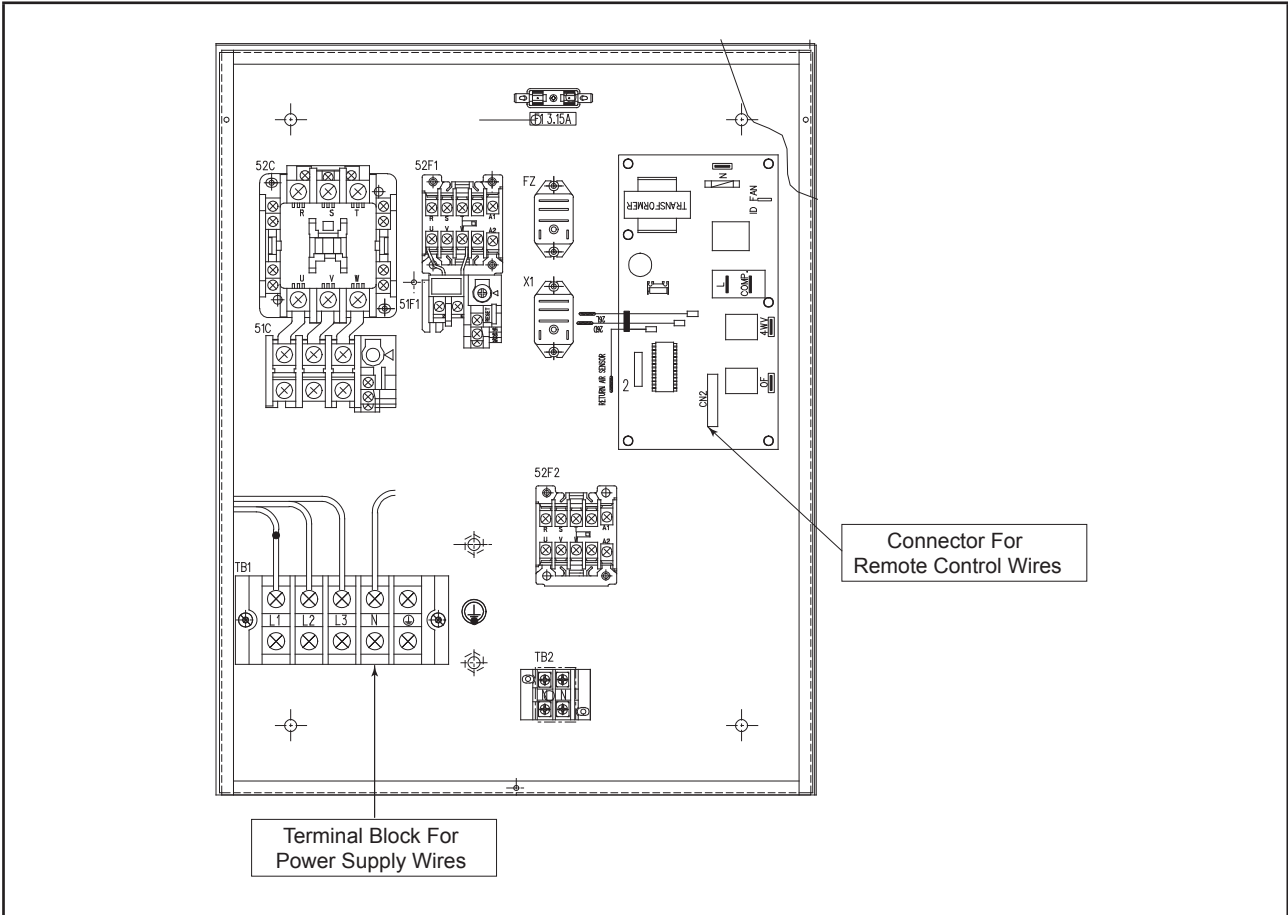

Control Module Of Unit UATYP80/100AGXY1

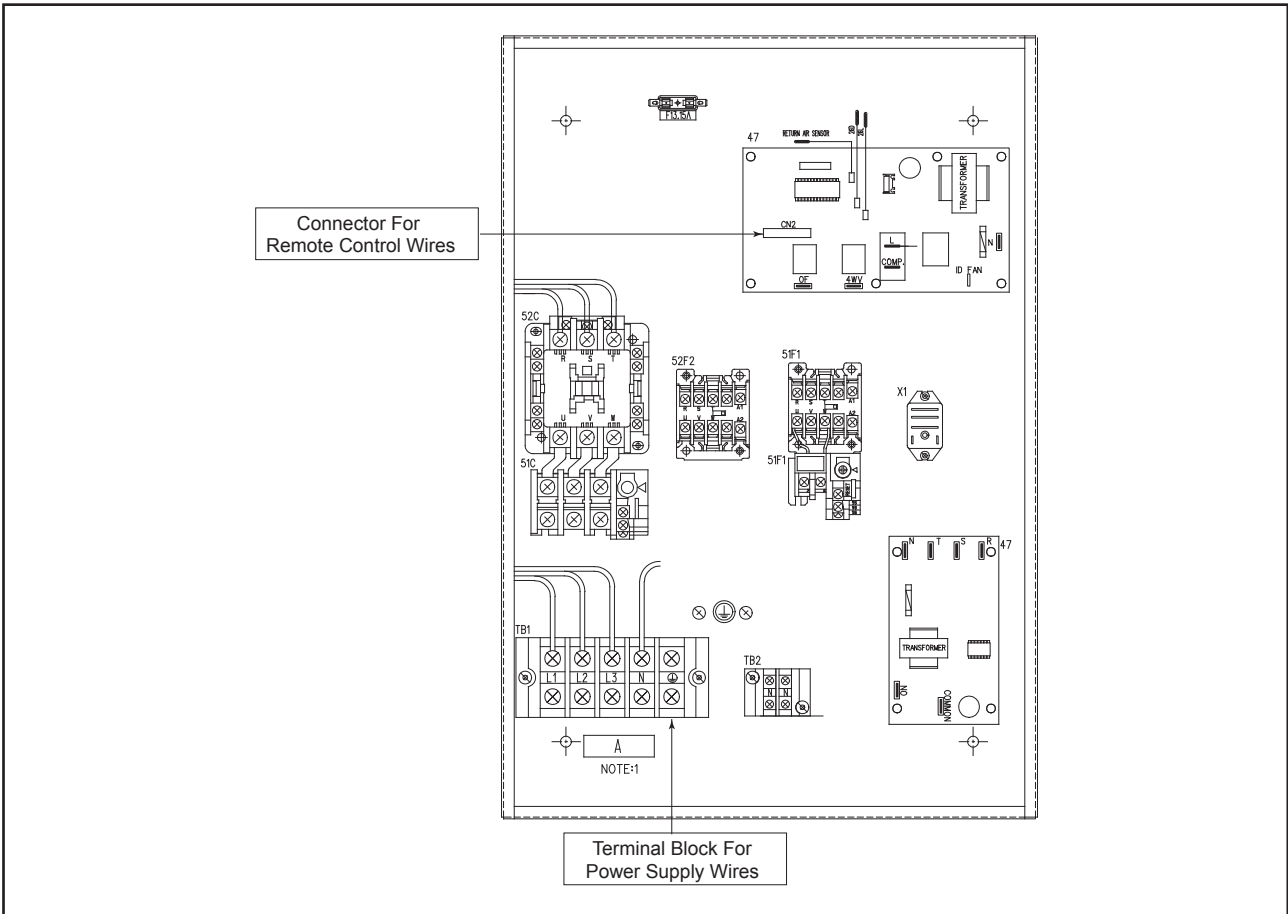

**Control Module Of Unit UATYP120AGXY1**

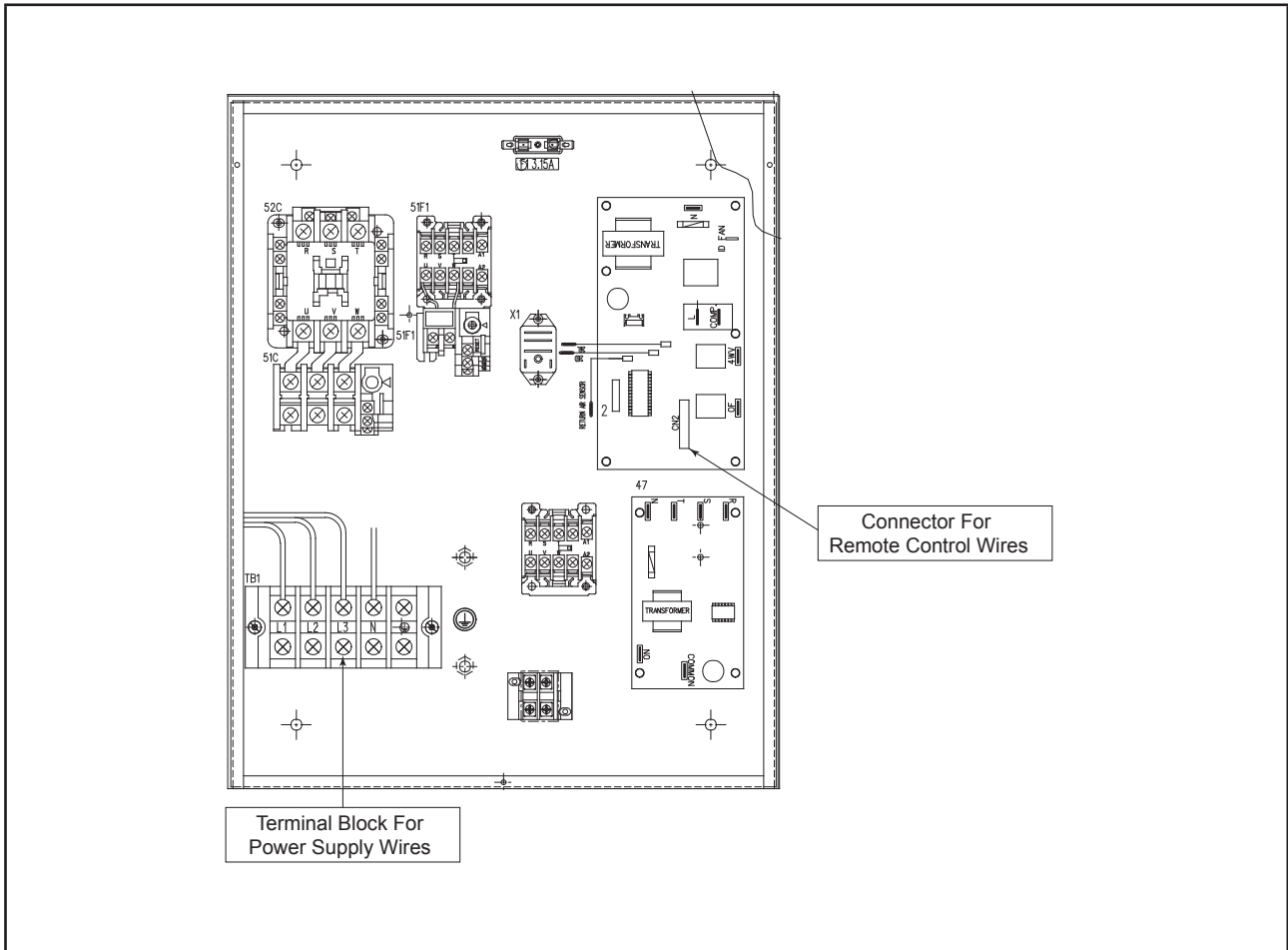

**Control Module Of Unit UATYP150/200AGXY1**

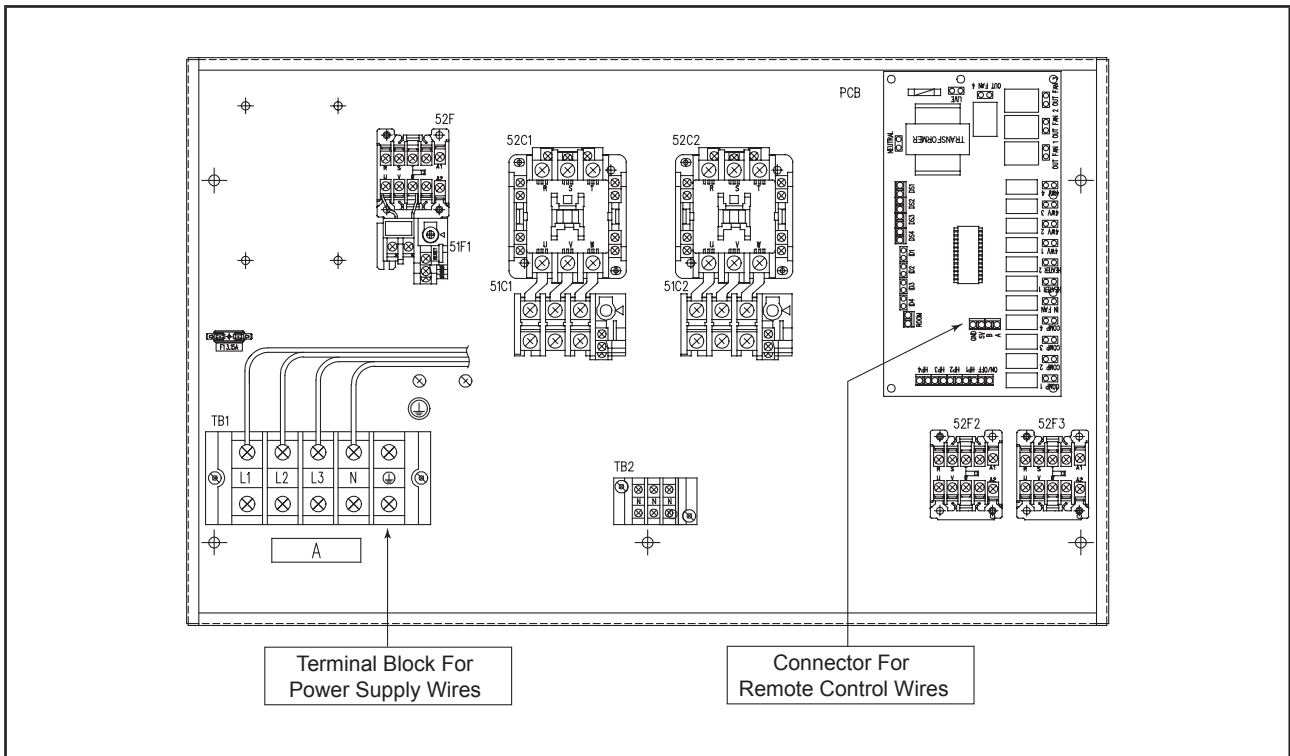

**Control Module Of Unit UATYP150/200AGXY1**

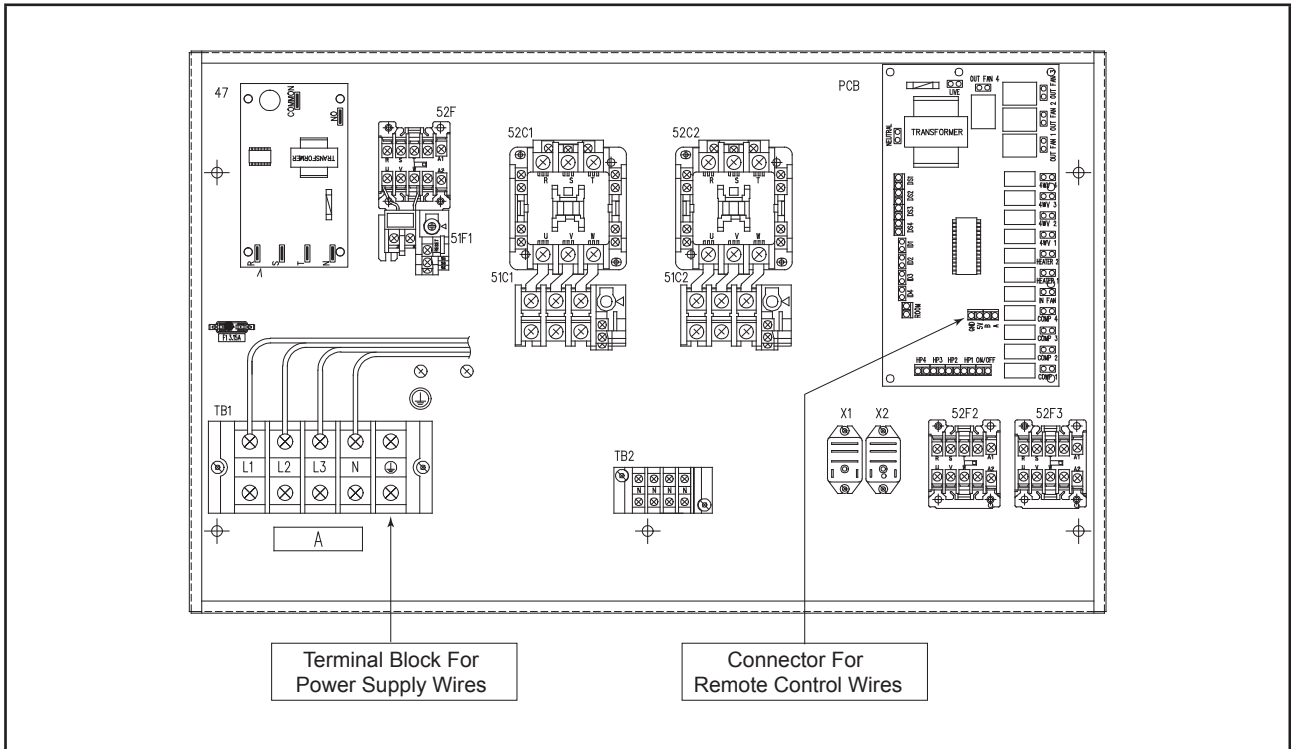

**Control Module Of Unit UATYP250/300AGXY1**

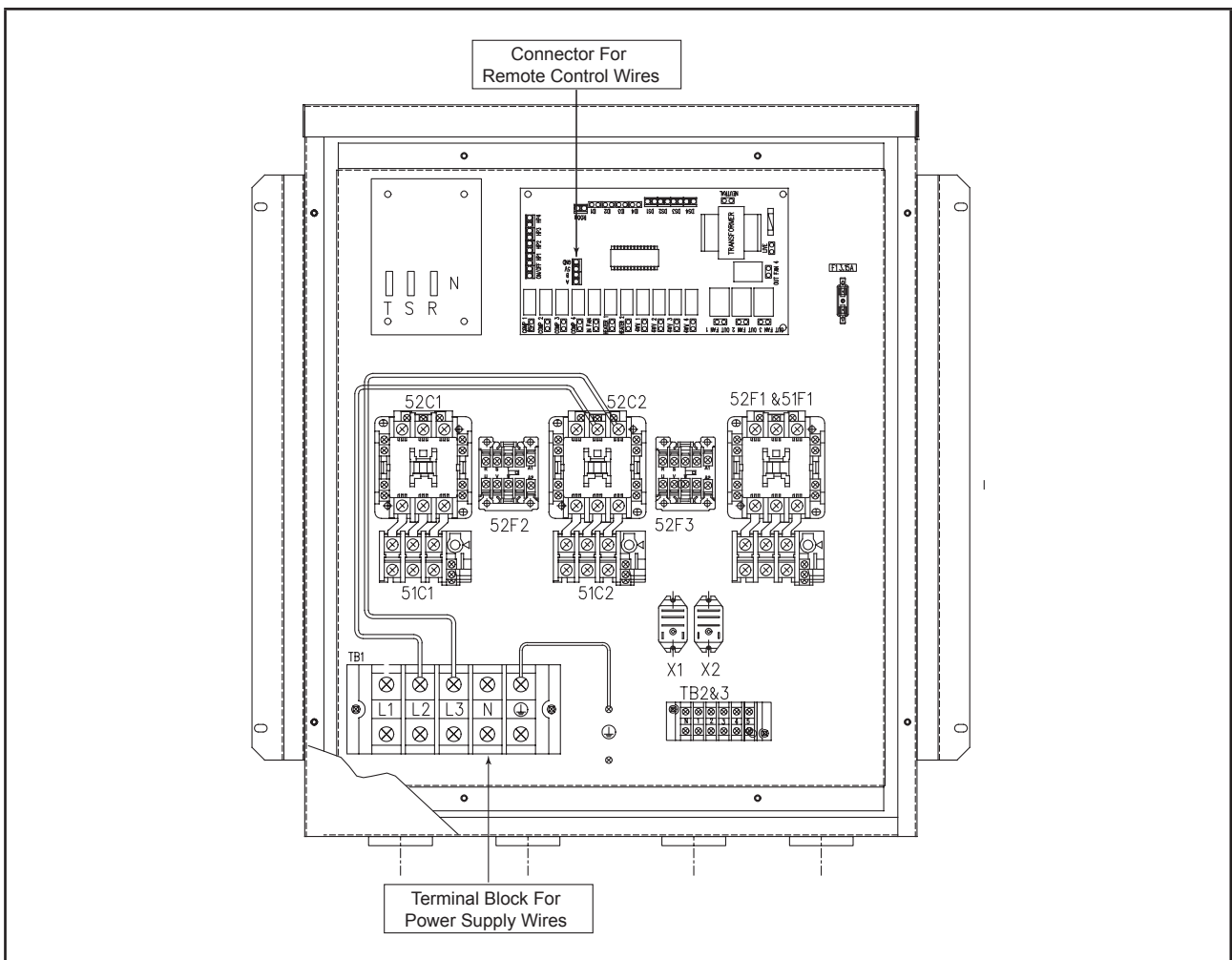

### Control Module Of Unit UAT(Y)P360/420AGXY1

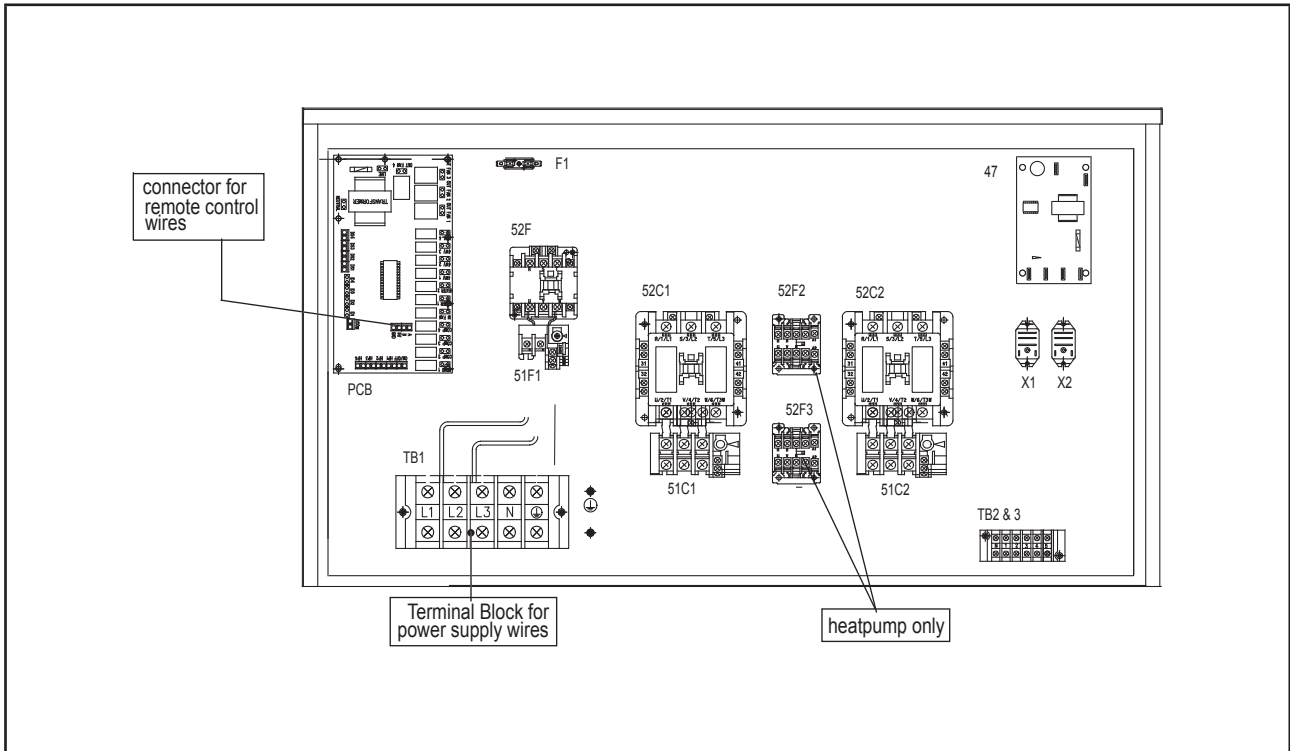

## 9. The Putting Condition Of The Belt

1. Set the parallel angle of the fan and the motor pulley as shown in table 1 and figure 1.
2. Set the tension of one belt when the flexion load is within the range as shown in figure 2 and table 2 at the proper flexion. ( $A = 0.016 \times C$  mm)
3. Adjust the suitable tension after the belt sit properly across the pulley (after working for 24-28 hours). When a new belt is used, adjust the suitable tension about 1.3 times the maximum value of the flexion load.
4. Readjust the belt every 2,000 hours after the first adjustment.  
Exchange the belt when the belt's surroundings length has expanded by 2% including the first expansion (about 1%) of the belt (after approximately 8,000 hours converted working time).

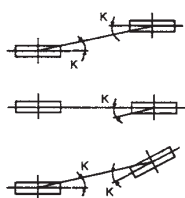

figure 1 Parallel degree of pulley

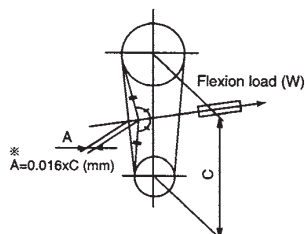

figure 2 Belt tension

Table 1

Parallel angle	K(i)	note
pulley	10 or less	Gap of 3mm every 1m
pulley		

Table 2

Size of Pulley Motor		Flexion load W(kgf)
mm	inch	
60-80	2.5-3.0	1.1-1.4
81-90	3.5	1.3-1.7
91-105	4	1.6-2.0
106-above	4.5-above	1.9-2.9

## 10. Before Starting The Trial Run

After having installed the unit, check that :

- (1) The unit is fixed securely.
- (2) The unit is installed properly.
- (3) The drain pipe is provided with a drain trap.
- (4) The electrical wiring has been connected correctly and the terminal screws have been properly tightened.
- (5) The duct work has been performed correctly.

Before turning the unit on:

- (1) Measure the resistance between the terminals of the electrical parts and ground to ensure that the value is at least 1.0M ohm.  
If the measured value is below 1.0M ohm, do not operate the unit.
- (2) The unit is using a phase protector.  
If wiring phase of power supply is mistaken, the unit does not run.  
Please reconfirm and modify wiring phase.

After the unit is turned on:

- (1) Check that the fans are rotating in the proper direction.
- (2) Check to see whether there are refrigerant leakage, and slack in power or transmission cable.
- (3) Check the operation of high-pressure switch.  
If the two lead wires of the outdoor unit fan motor are disconnected from the contactor and cooling is performed, the high-pressure switch should function and stop the unit after 5 to 10 minutes.  
Perform trial operation after completion of above items.

## 11. Before Operating The Unit

### 1. Check points for operation

Check the following points before you operate your air conditioner.

(1) Check that there is nothing blocking the flow of air from the air outlet into the air inlet.

#### Indoor Side

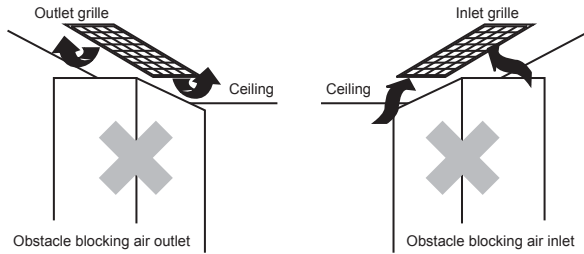

#### Outdoor Side

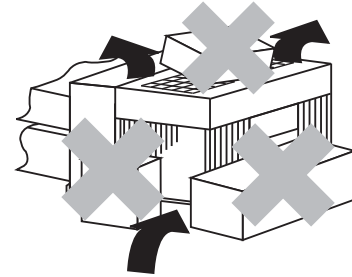

(2) Make sure the air conditioner is properly grounded by checking the ground terminal.

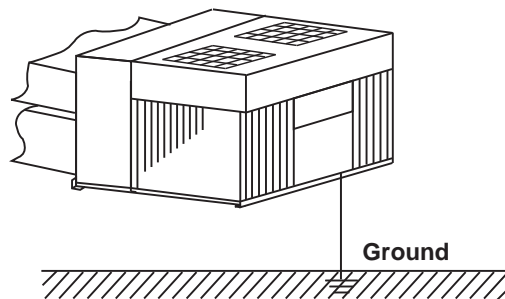

### 2. Caution for use

Keep the following points in mind to safeguard against failures and breakdowns.

- For safety, confirm that the earth terminal has been connected to the earth wire correctly.
- Never block or cover the unit's intakes or outlets. It will reduce the unit's efficiency.
- To start the unit again after it is stopped, ensure 3 minutes has elapsed before turning the unit ON. Repeated stopping and starting within 3 minutes gives improper force to the machine. This can cause the fuse or power source to trip.

# Sound Data

## Sound Pressure Level

Model	1/1 Octave Sound Pressure (dB, ref 20µPa)							Overall (dBA)	Noise Criteria
	125Hz	250Hz	500Hz	1kHz	2kHz	4kHz	8kHz		
UAT(Y)P60AGXY1	67	61	59	60	55	49	42	63	59
UAT(Y)P80AGXY1	68	65	64	62	54	49	39	65	61
UAT(Y)P100AGXY1	69	67	64	60	56	51	42	66	58
UAT(Y)P120AGXY1	68	64	62	65	60	53	45	68	64
UAT(Y)P150AGXY1	74	68	68	67	60	53	44	70	66
UAT(Y)P200AGXY1	74	69	67	66	60	52	43	70	65
UAT(Y)P250AGXY1	76	72	70	71	65	55	46	74	70*
UAT(Y)P300AGXY1	77	72	71	72	65	55	46	74	71*
UAT(Y)P360AGXY1	67	74	74	75	76	69	60	80	>70*
UAT(Y)P420AGXY1	72	76	76	75	75	69	58	80	>70*

Note:

- UAT(Y)P80AGXY1, UAT(Y)P100AGXY1, UAT(Y)P150AGXY1 and UAT(Y)P200AGXY1  
- Microphone position: 1 m in front of the unit and 1 m above the floor.
- UAT(Y)P60AGXY1, UAT(Y)P120AGXY1, UAT(Y)P250AGXY1, UAT(Y)P300AGXY1, UAT(Y)P360AGXY1 and UAT(Y)P420AGXY1  
- Microphone position: 1 m from the service panel and 1 m height from the floor level.

## NC Curve

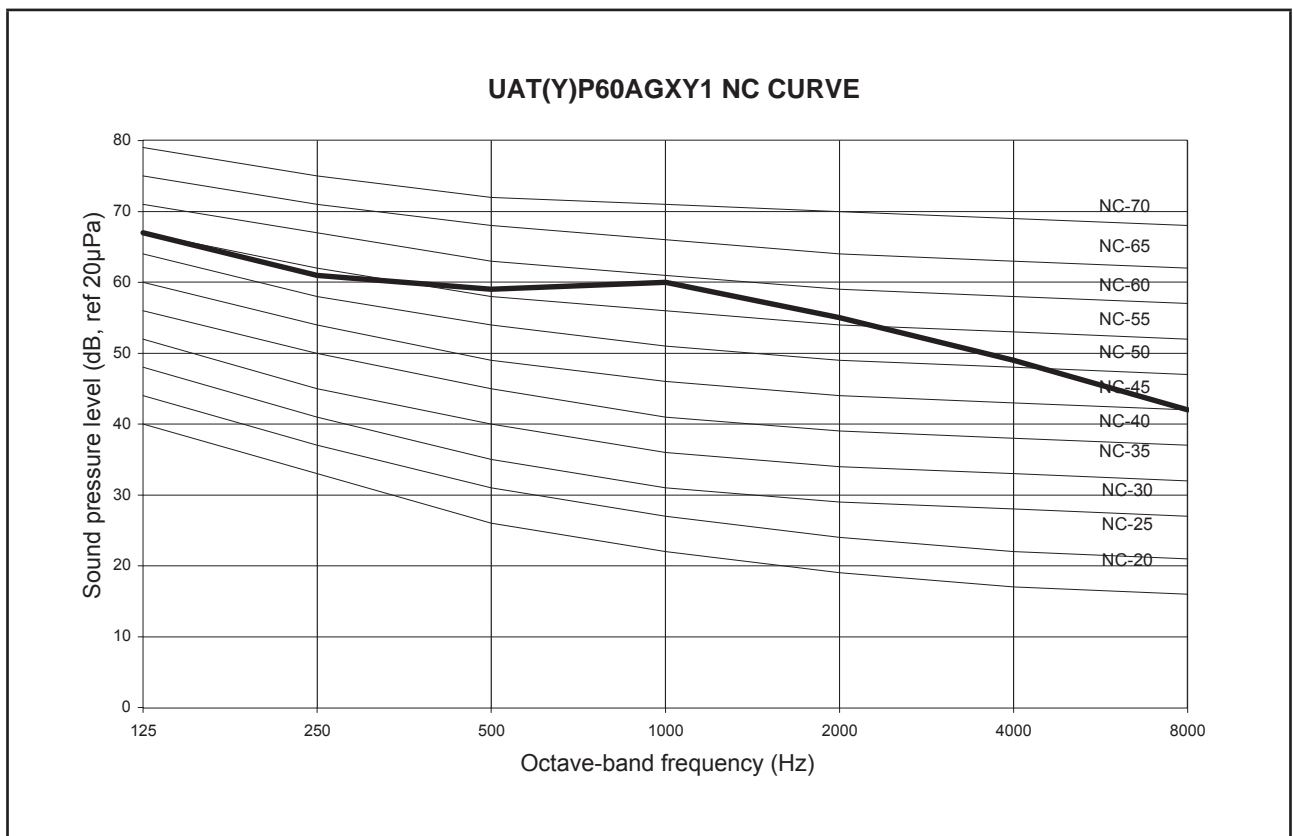

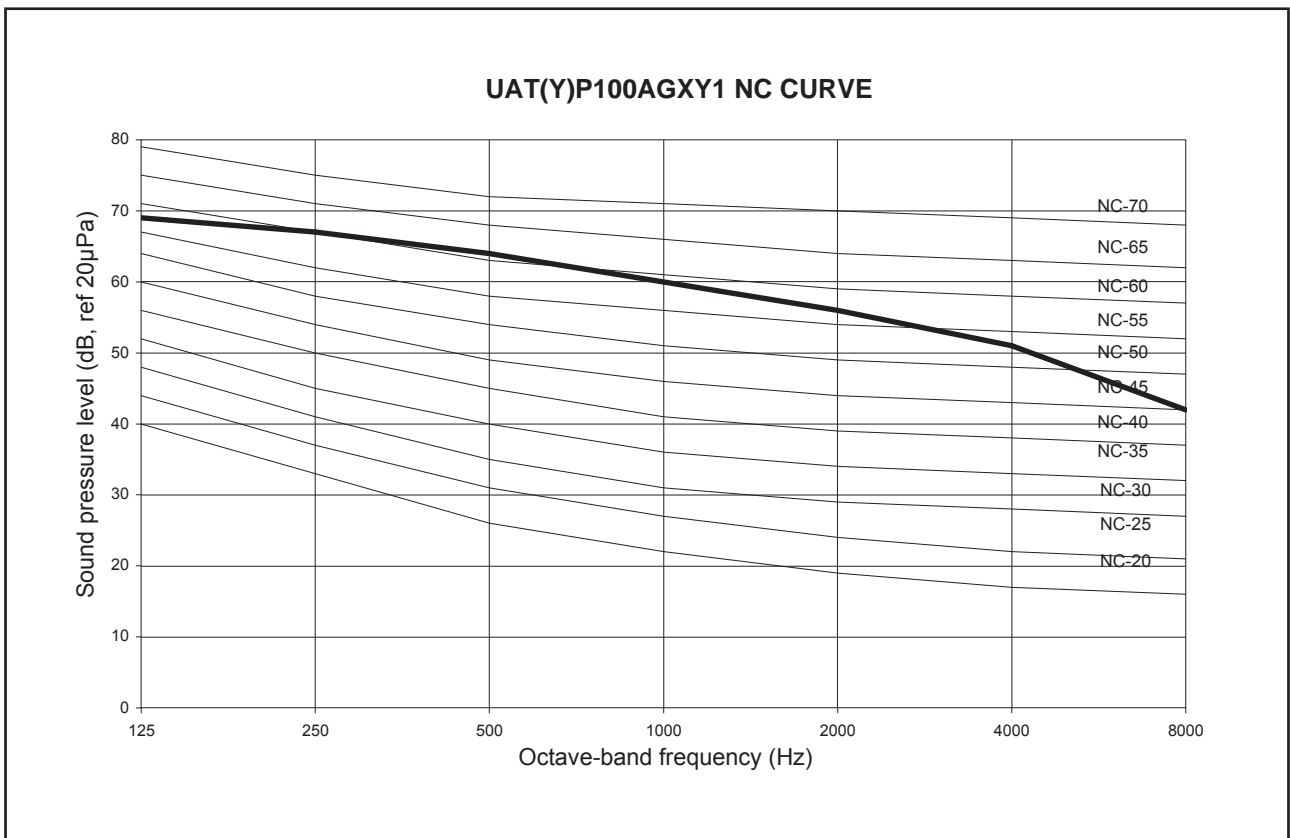
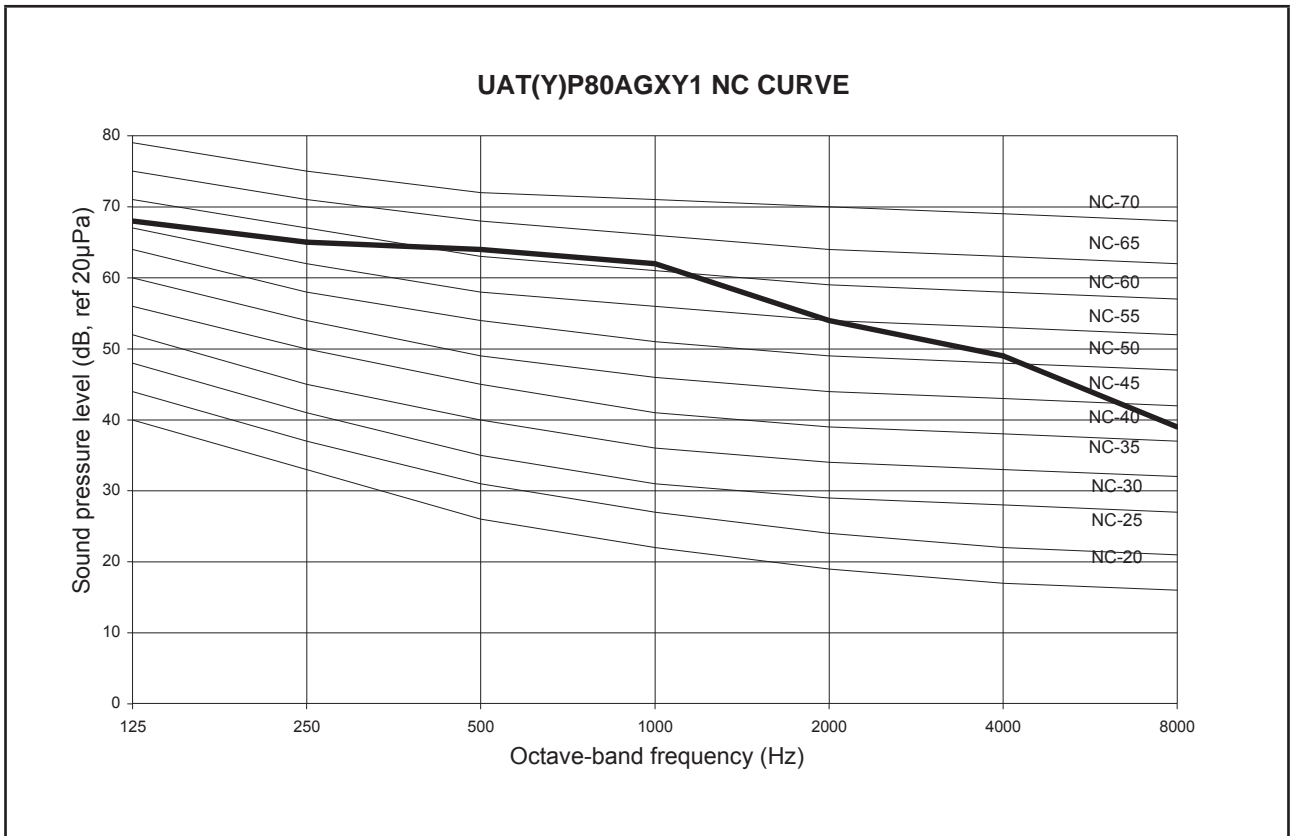

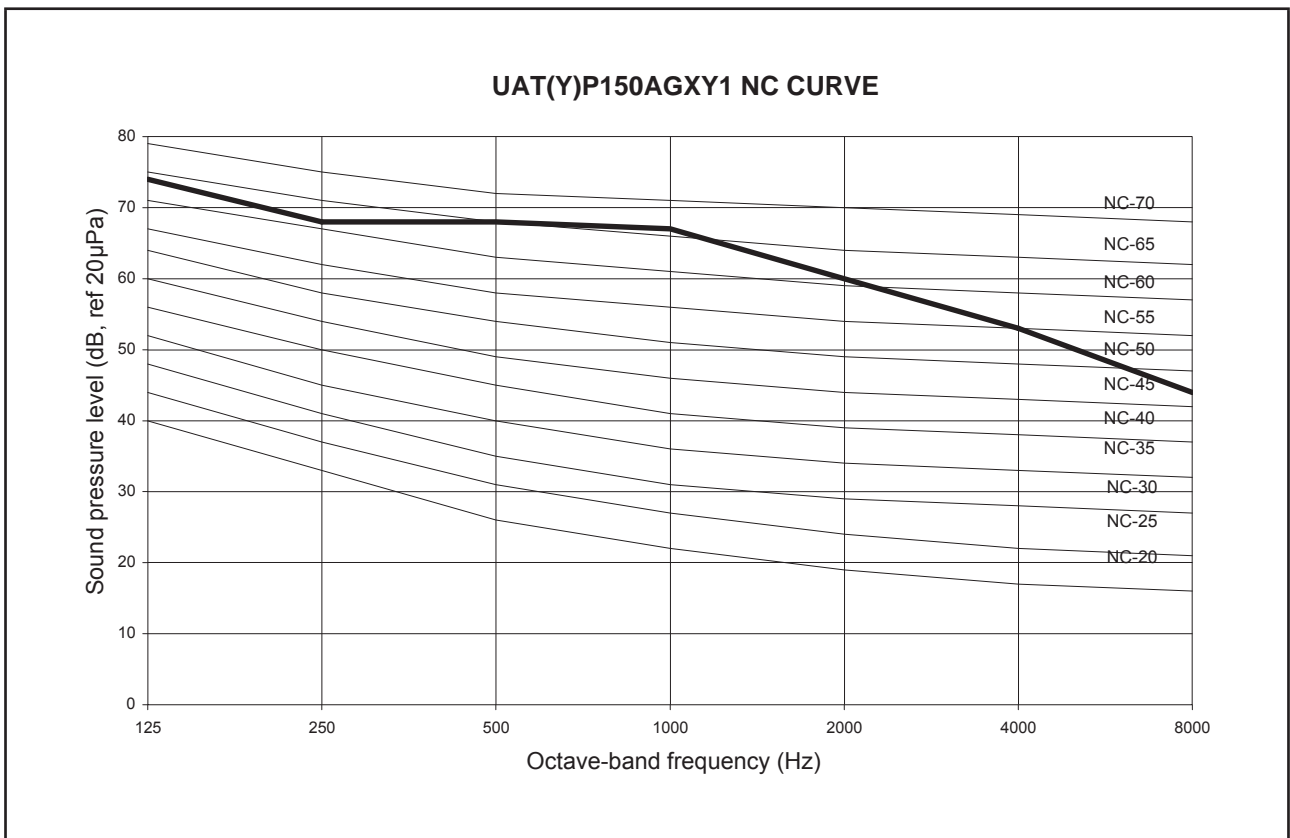
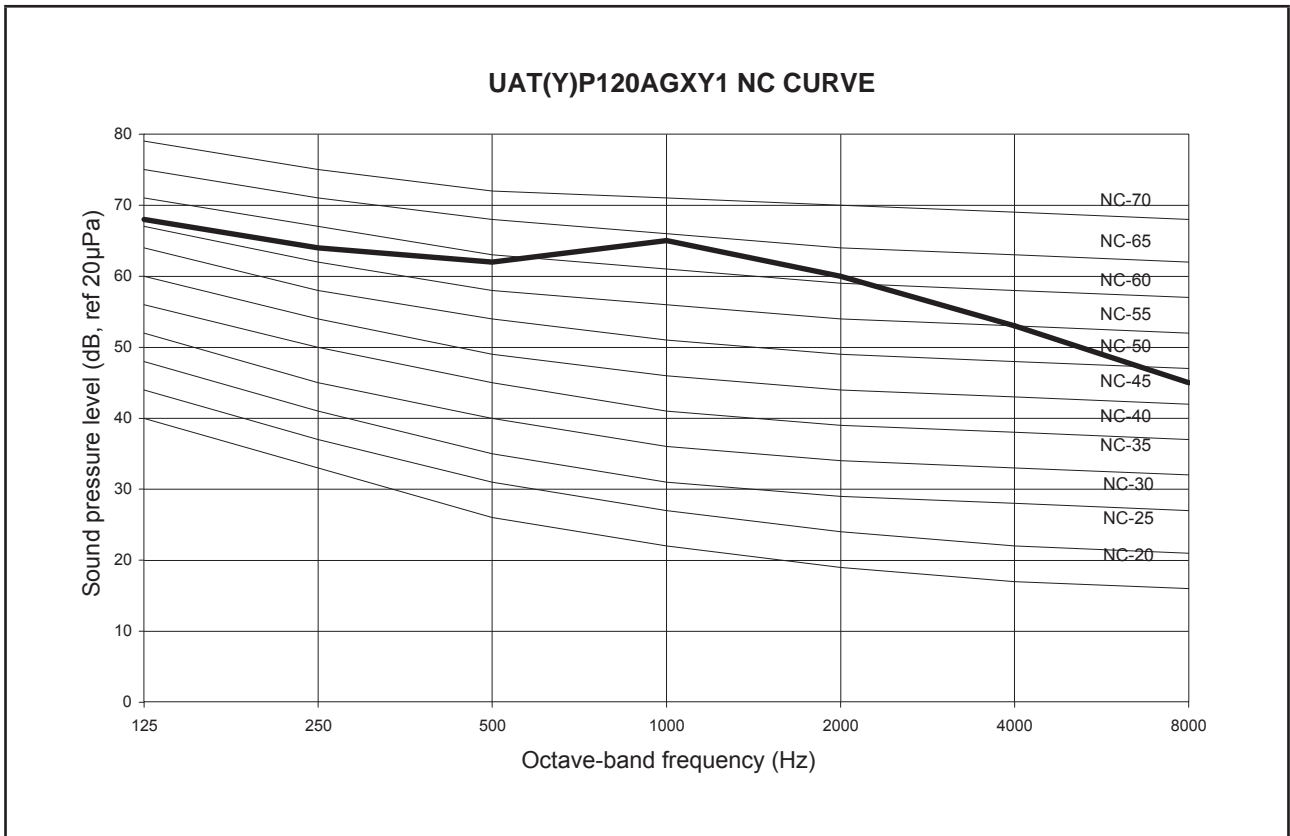

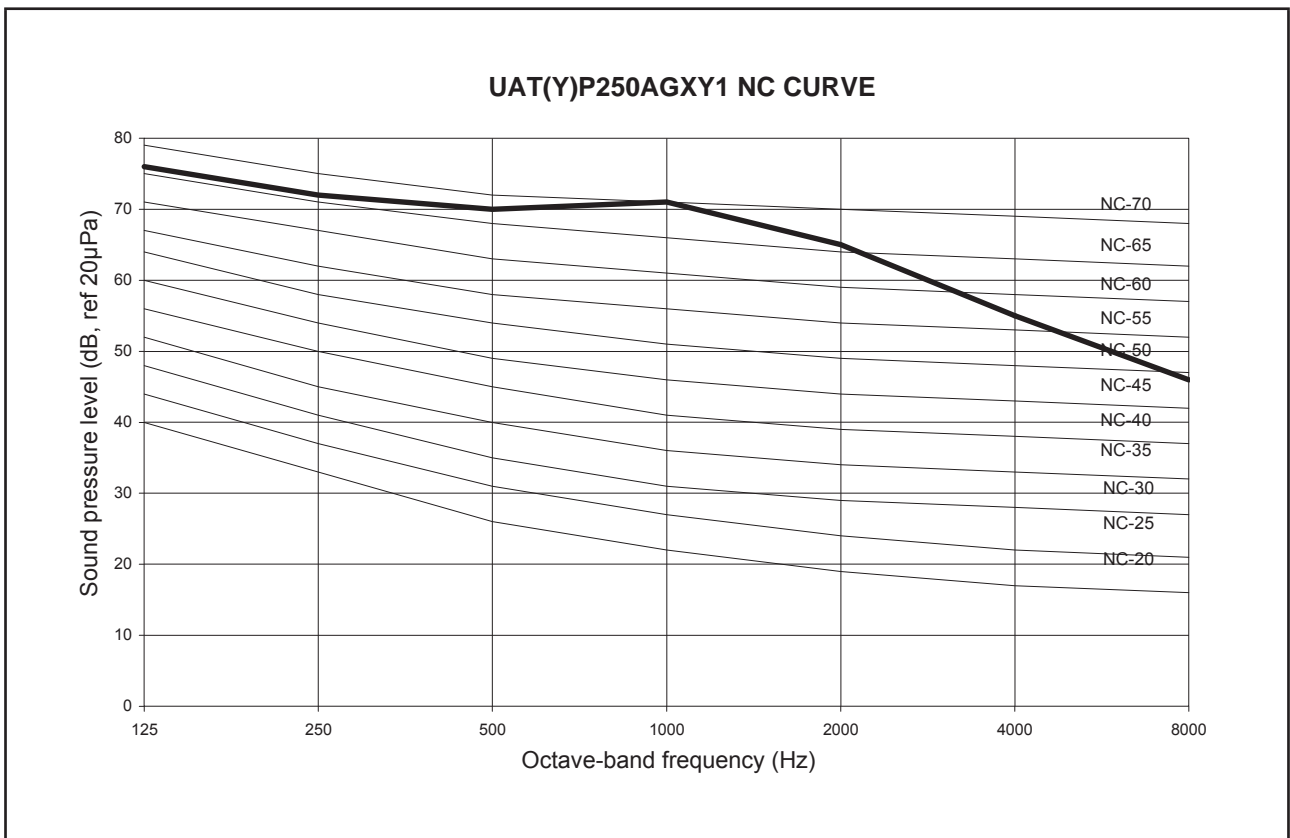
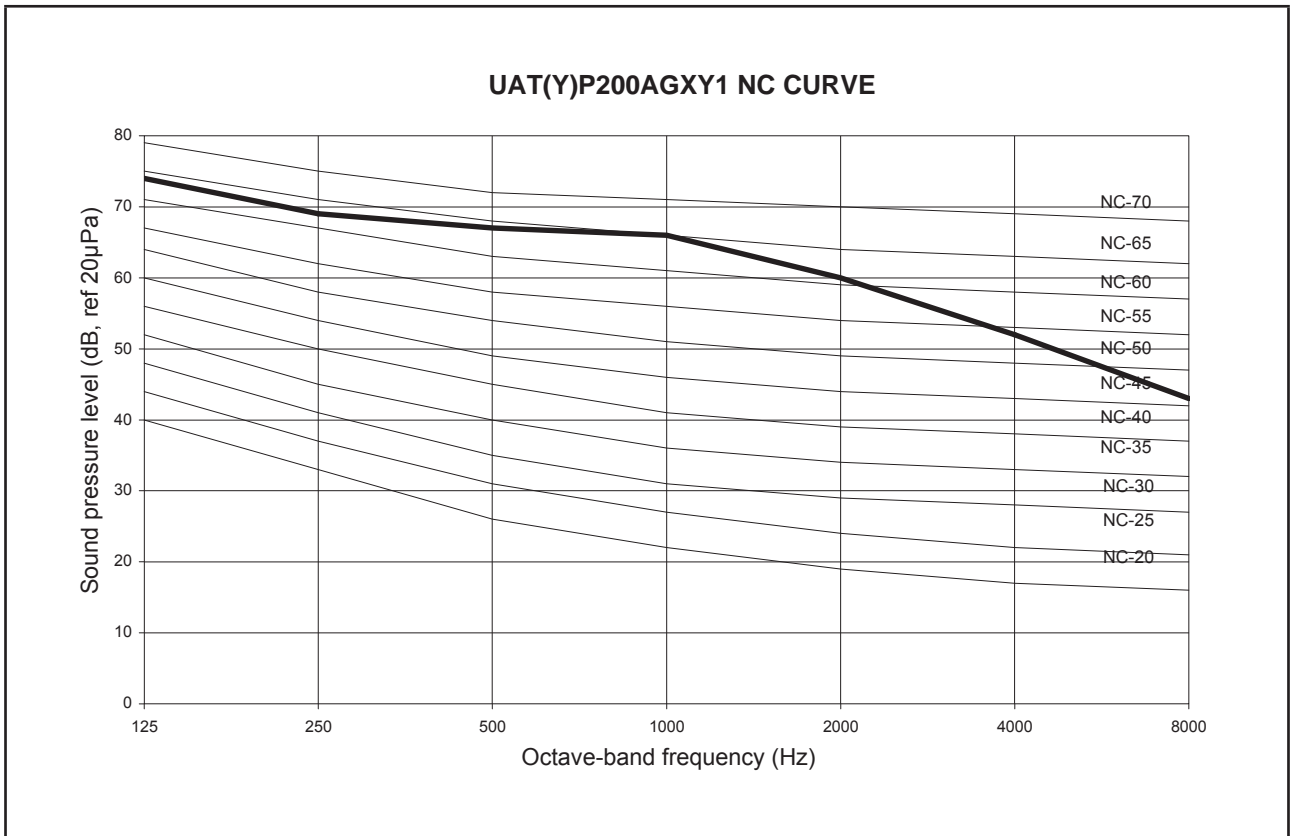

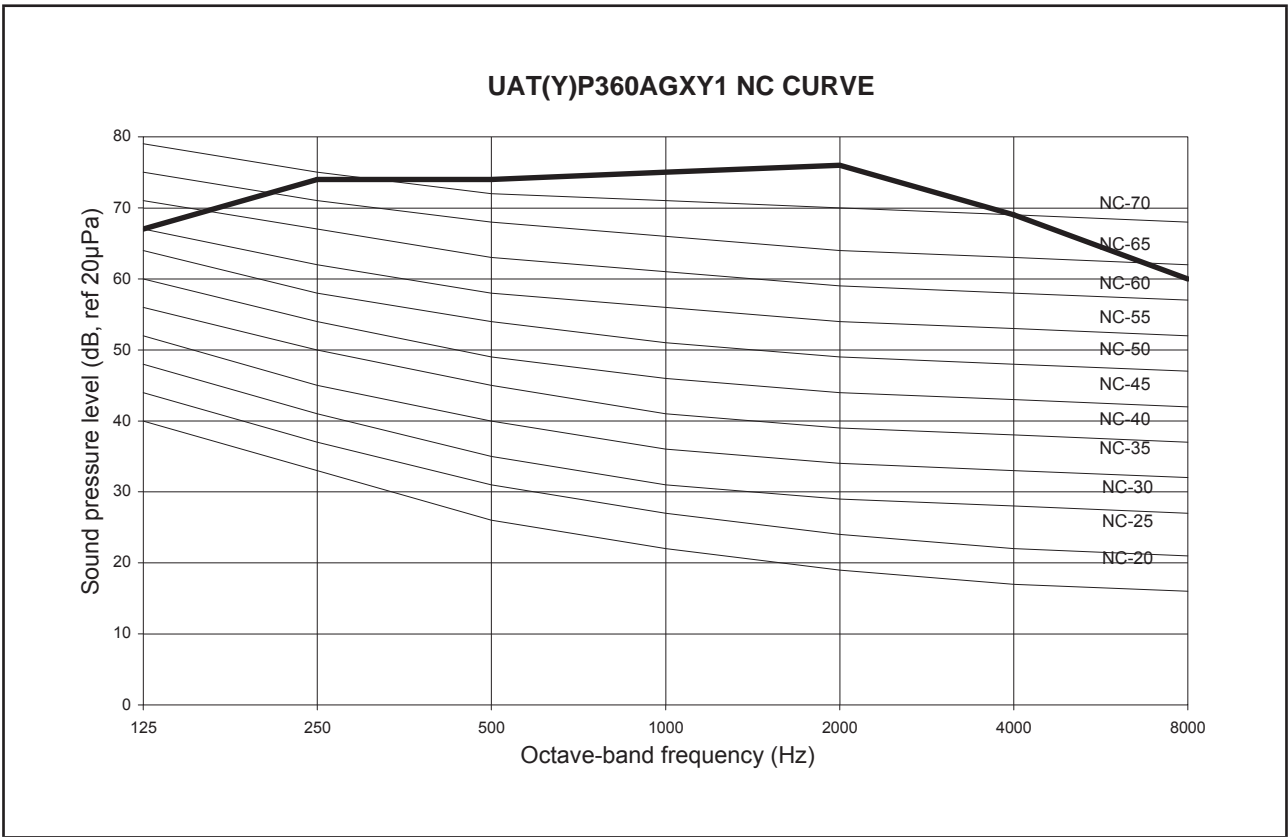
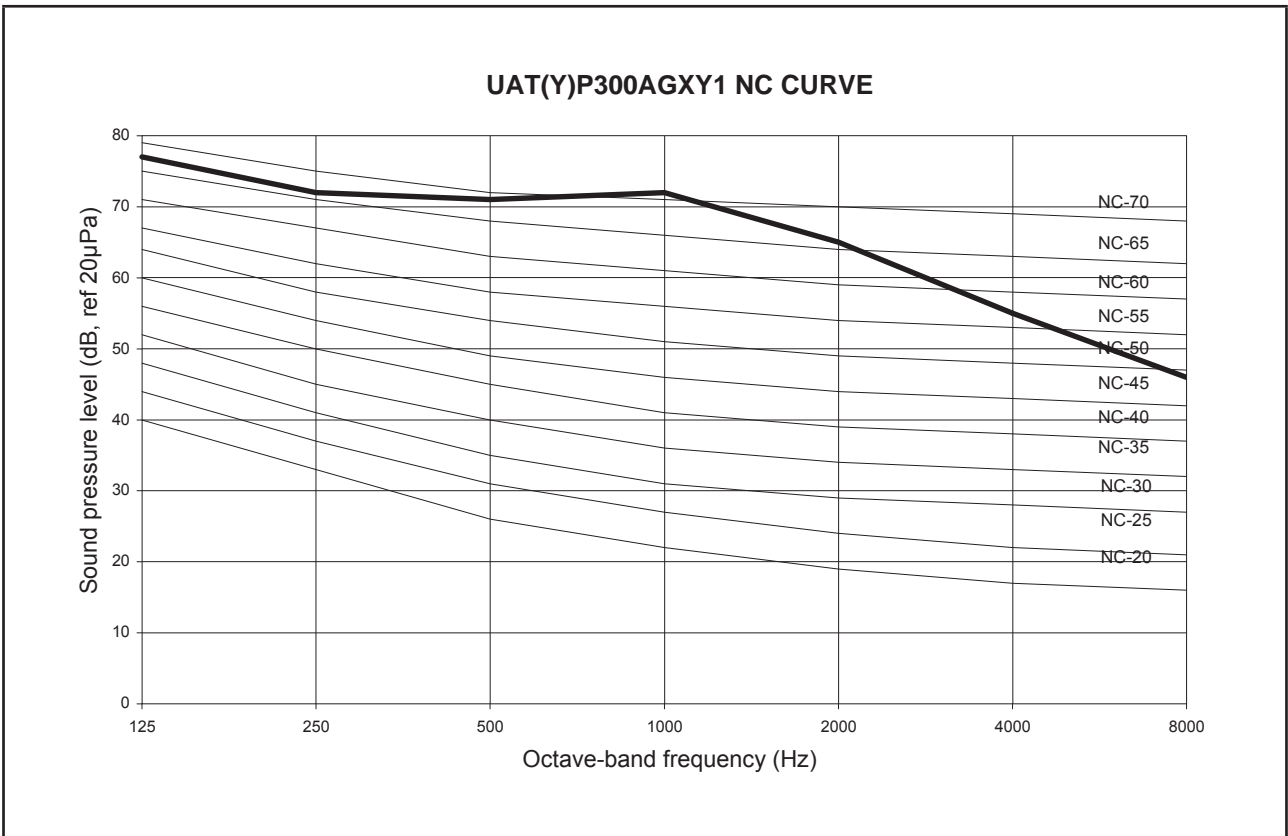

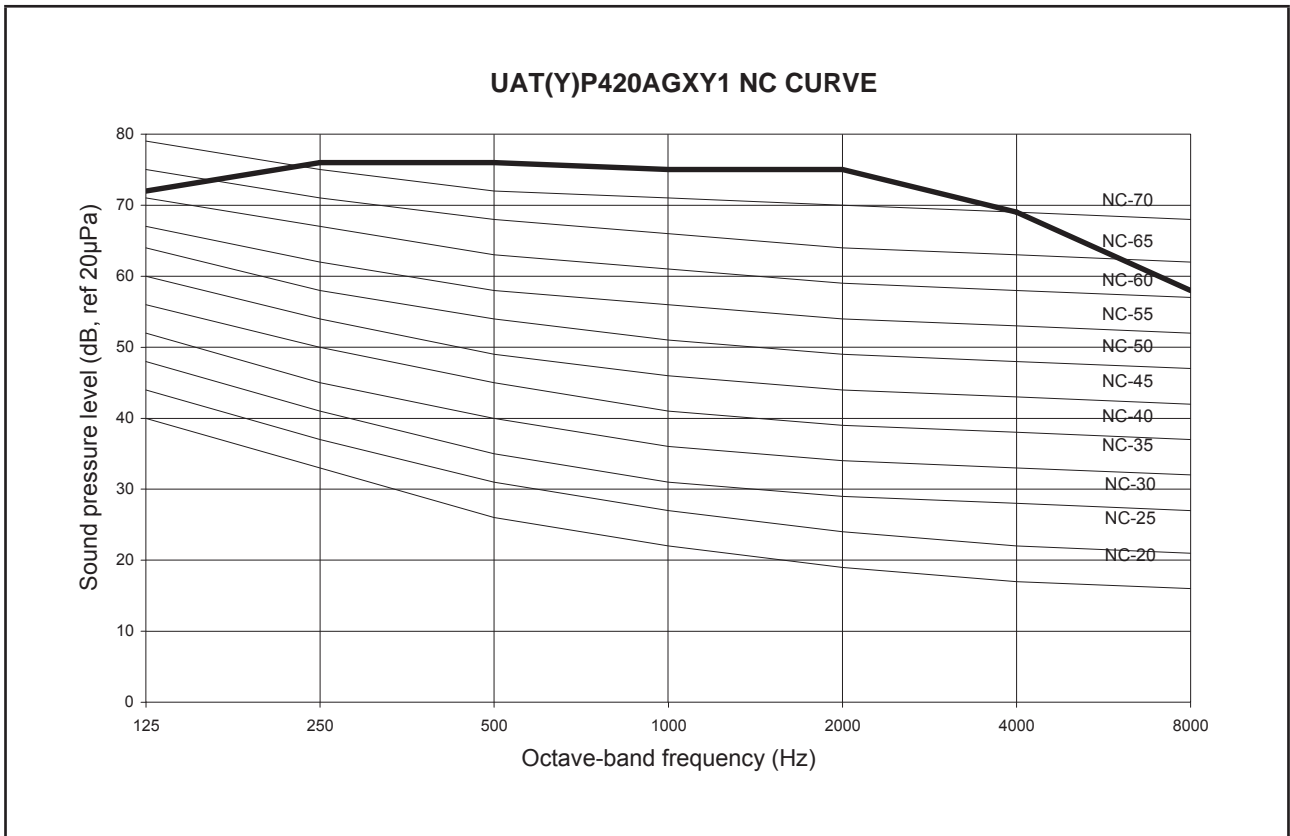

# Selection Process

## Drive Package

The following are the design requirements for UATP100AGXY1 unit:	
<b>Model:</b>	<b>UATP100AGXY1</b>
Supply Air Quantity	= 3800 CFM
External Static Pressure	= 150 Pa
Step 1:	From the fan curve (at 3800 CFM), Standard operating system; Internal Static Pressure = <b>160</b> Pa
Step 2:	Therefore at 3800 CFM and 150 Pa external static pressure, Total Static Pressure = 150 + 160 Pa = <b>310</b> Pa
Step 3:	From the blower curve, the design requirement calls for RPM about 1200 RPM. From the table: Motor pulley = 106 mm Blower pulley = 125 mm Motor RPM = 1420  In order to obtain 1380 RPM, we calculate the new blower pulley as: (while maintaining the motor pulley) Db = 106 x (1420/1380) = 109.1 mm  Let us take close approximation of 110 mm diameter pulley size Recheck, with Db = <b>110mm</b> Blower pulley = 1420 x (106/110) = <b>1368.4. RPM</b>  We thus need to change the blower pulley from 125 mm to 110 mm in order to obtain the higher operating static pressure.
Step 4:	When the pulley is changed, the V-belt length must be rechecked. We have for horizontal air throw configuration: V-belt length, L = 2C + 1.57 (Db + Dm) = (2 x 174) + 1.57(110+ 106) = 687.12 We thus can use a belt with a length of <b>687mm</b>  where, C = distance between the centres of the two pulleys Db = diameter of blower pulley Dm = diameter of motor pulley
Step 5:	From the blower curve, we can also notice that the motor power input has maintained within the current operating range of the standard unit's motor. <b>Summary:</b> i) Fan motor kW = <b>2.2</b> kW ii) Blower pulley diameter = <b>110</b> mm iii) V-belt siz = <b>687</b> mm

Note: Factory supplied rooftop is only with standard drive package.  
All other changes are only given as example and need to be field supply.

## DIMENSIONAL DATA

Below tables summarizes the pulley data, motor size used for the RT series, as manufactured.

Model	Blower Pulley, Db		Motor Pulley, Dm		V Belt	
	Type	Diameter (mm)	Type	Diameter (mm)	Type	Length (mm)
UAT(Y)P60AGXY1	SPZ 1	125	SPZ 1	95	SPZ	750
UAT(Y)P80AGXY1	SPZ 1	140	SPZ 1	100	SPZ	737
UAT(Y)P100AGXY1	SPZ 1	125	SPZ 1	106	SPZ	710
UAT(Y)P120AGXY1	SPZ 1	125	SPZ 1	106	SPZ	710
UAT(Y)P150AGXY1	SPA 2	160	SPA 2	90	SPA	782
UAT(Y)P200AGXY1	SPA 2	170	SPA 2	100	SPA	757
UAT(Y)P250AGXY1	SPA 2	224	SPA 2	125	SPZ	1662
UAT(Y)P300AGXY1	SPA 2	224	SPA 2	140	SPZ	1700
UAT(Y)P360AGXY1	SPA	280	VPT	139	SPA	2132
UAT(Y)P420AGXY1	SPA	250	VPT	139	SPA	2060

Model	Pulley Center Distance, C (mm)			Motor	
	Nom	Min	Max	kw	RPM
UAT(Y)P60AGXY1	203	203	245	0.75	1420
UAT(Y)P80AGXY1	180	175	190	1.1	1420
UAT(Y)P100AGXY1	174	170	185	1.5	1420
UAT(Y)P120AGXY1	174	170	185	1.5	1420
UAT(Y)P150AGXY1	195	190	205	2.2	1430
UAT(Y)P200AGXY1	167	165	180	3.7	1430
UAT(Y)P250AGXY1	558	558	572	5.5	1440
UAT(Y)P300AGXY1	565	558	572	7.5	1440
UAT(Y)P360AGXY1	748	730	763	7.5	1440
UAT(Y)P420AGXY1	739	730	763	7.5	1440

Blower Curve

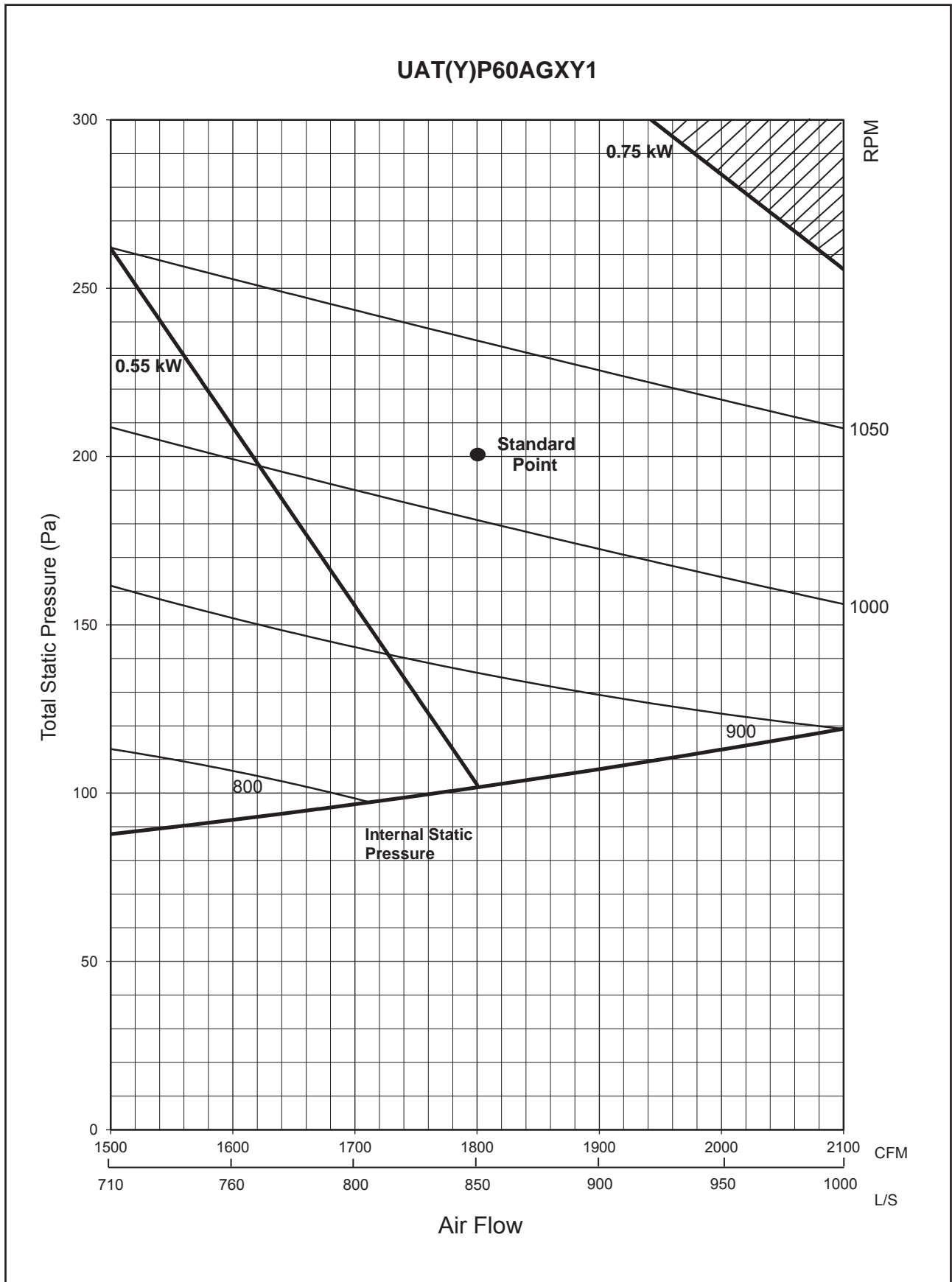

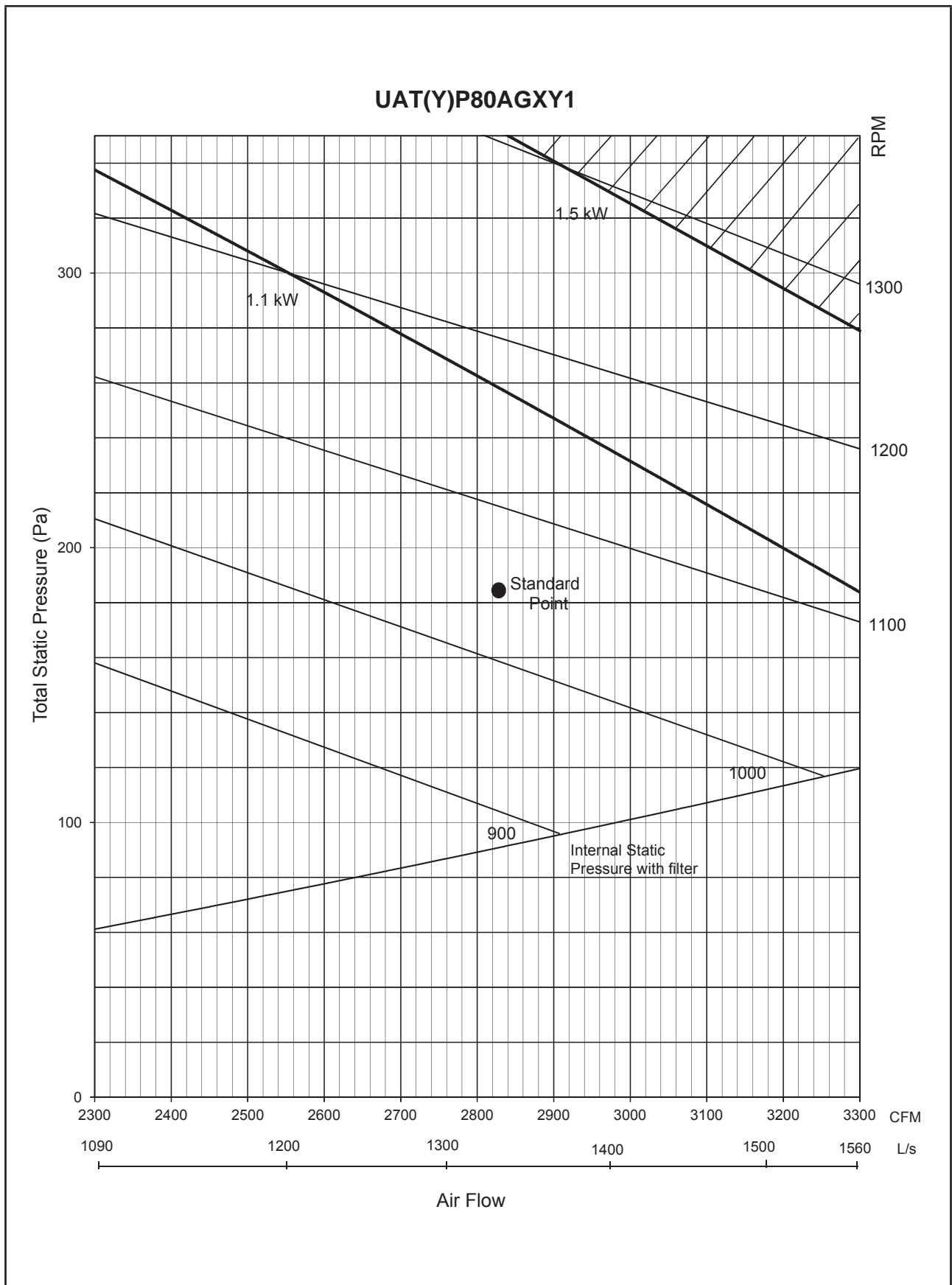

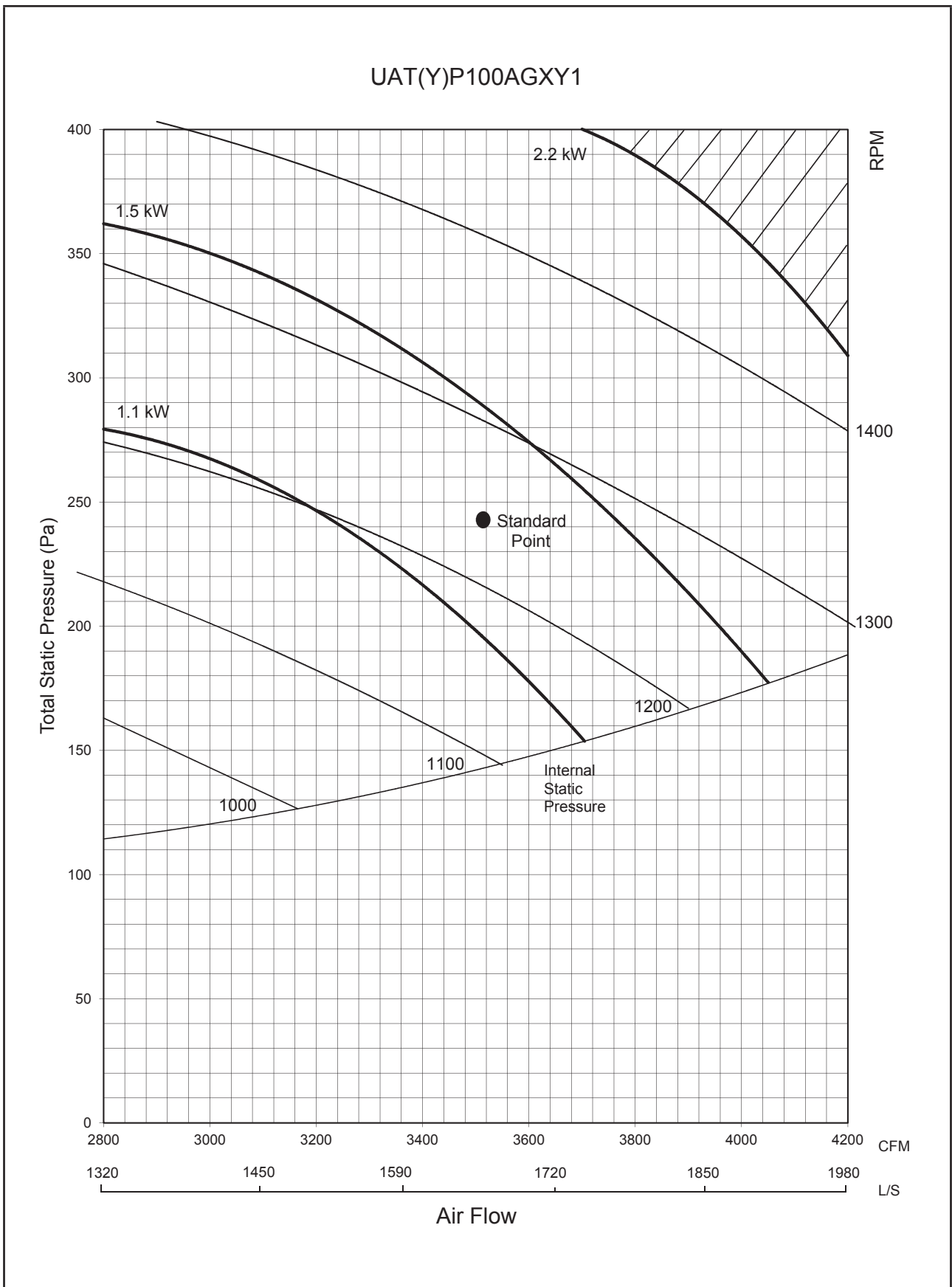

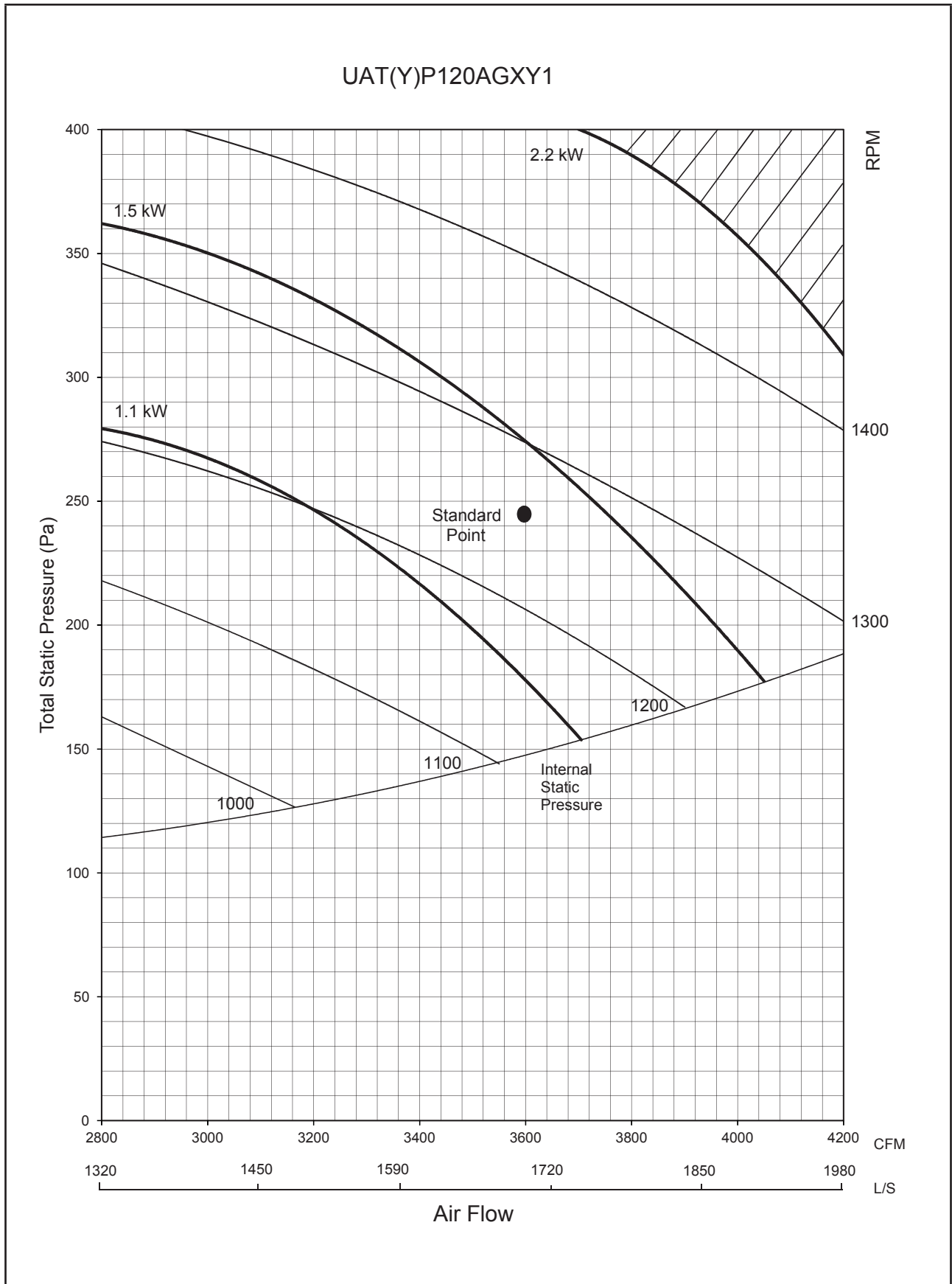

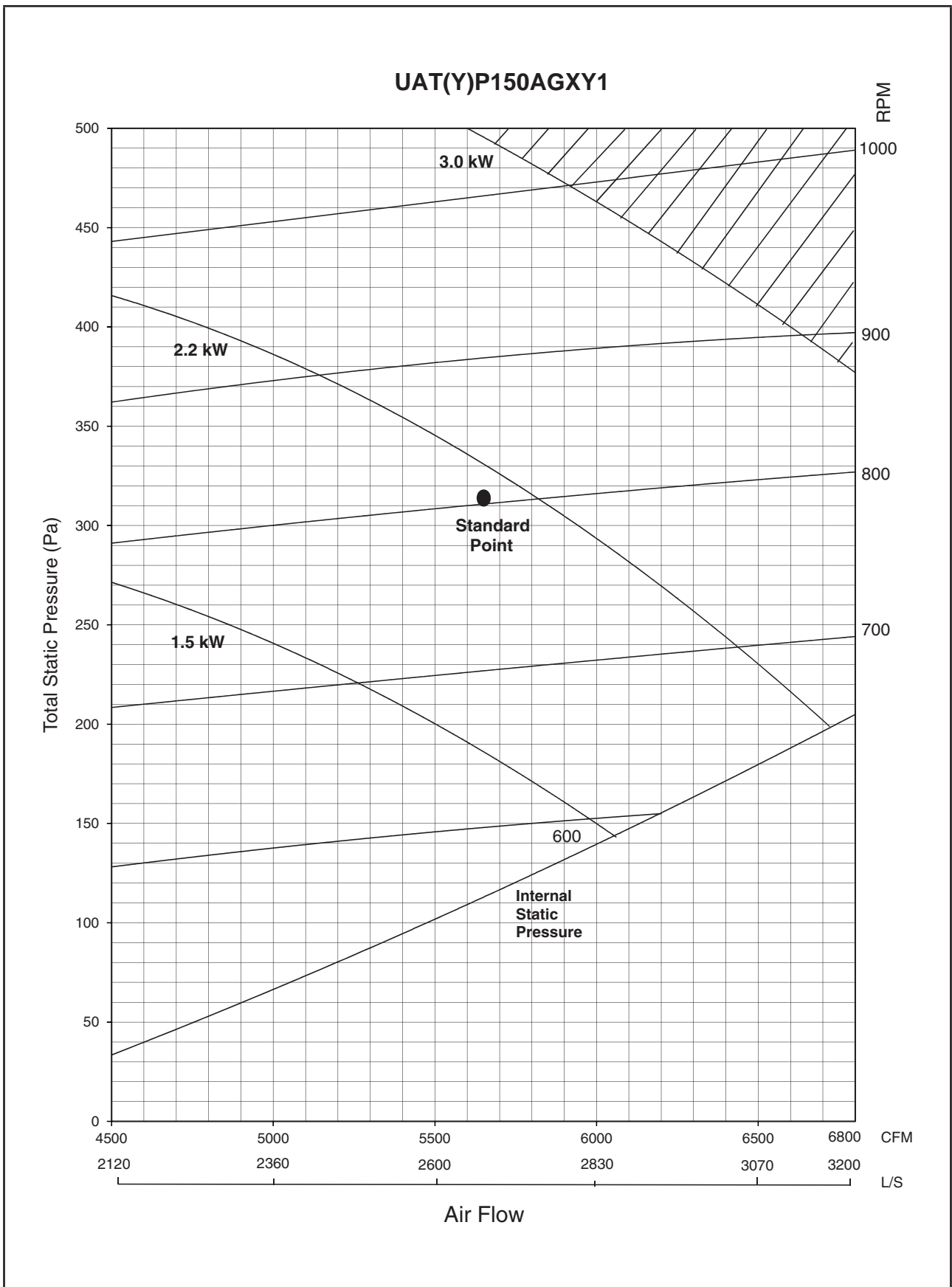

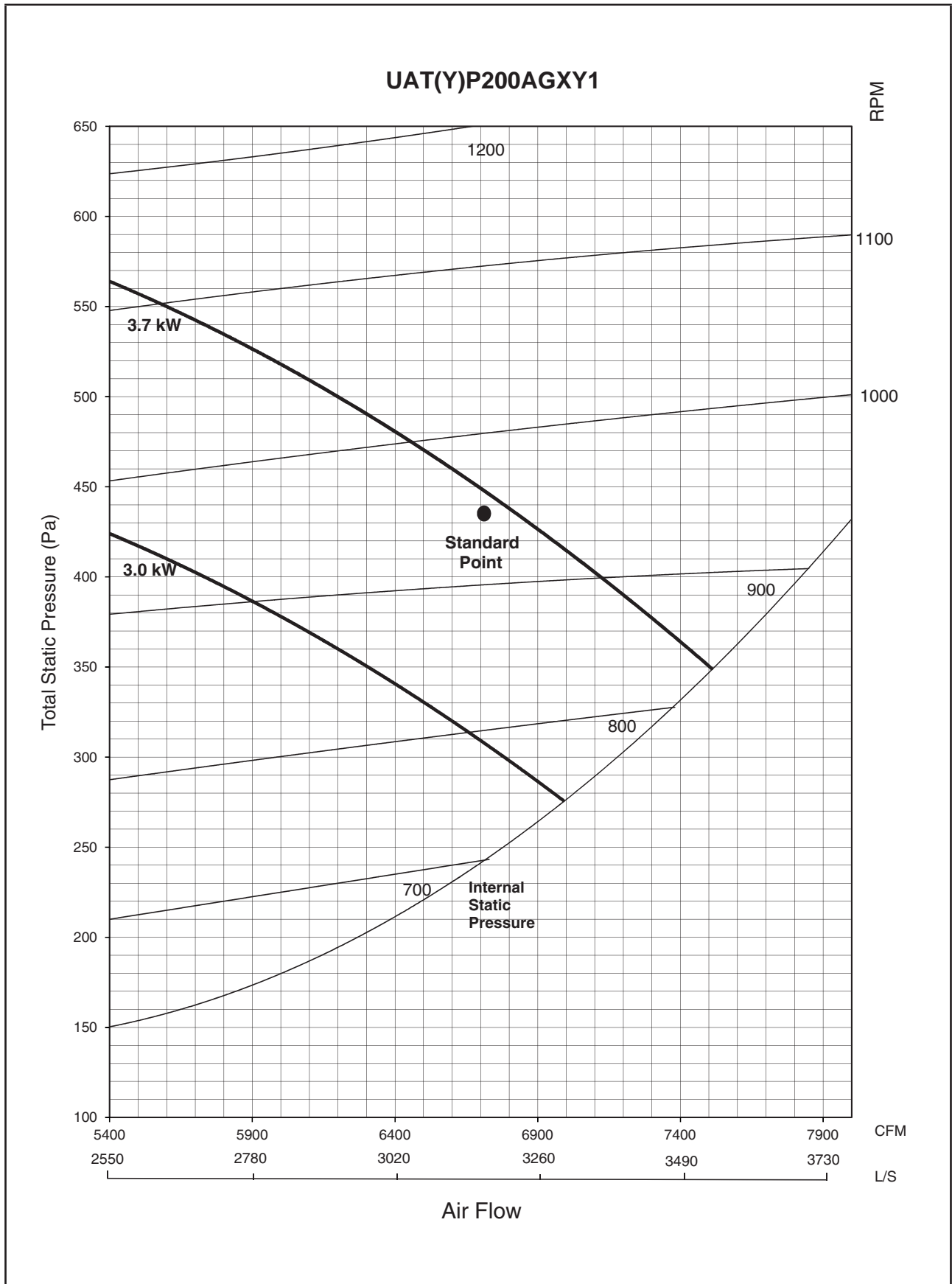

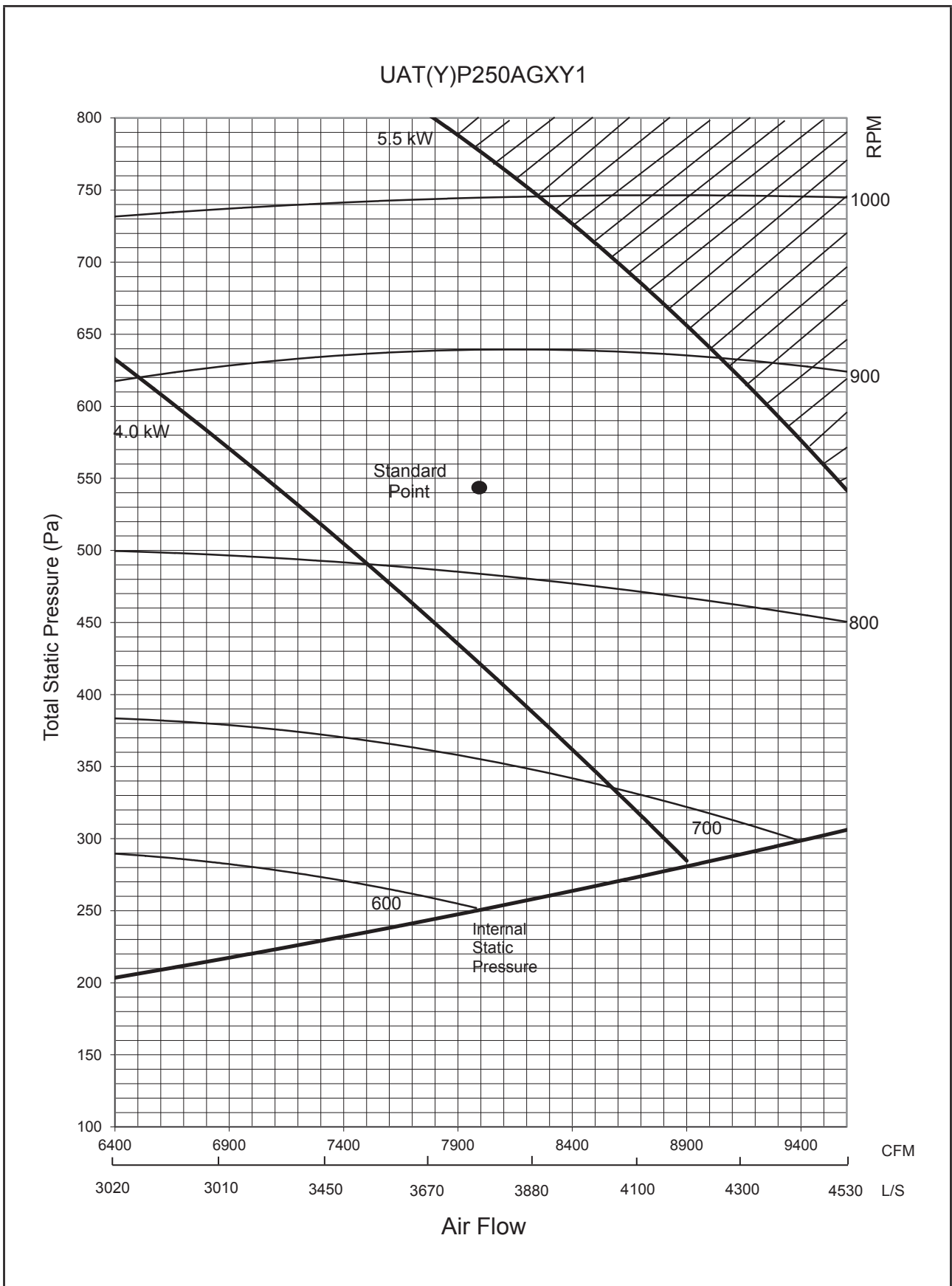

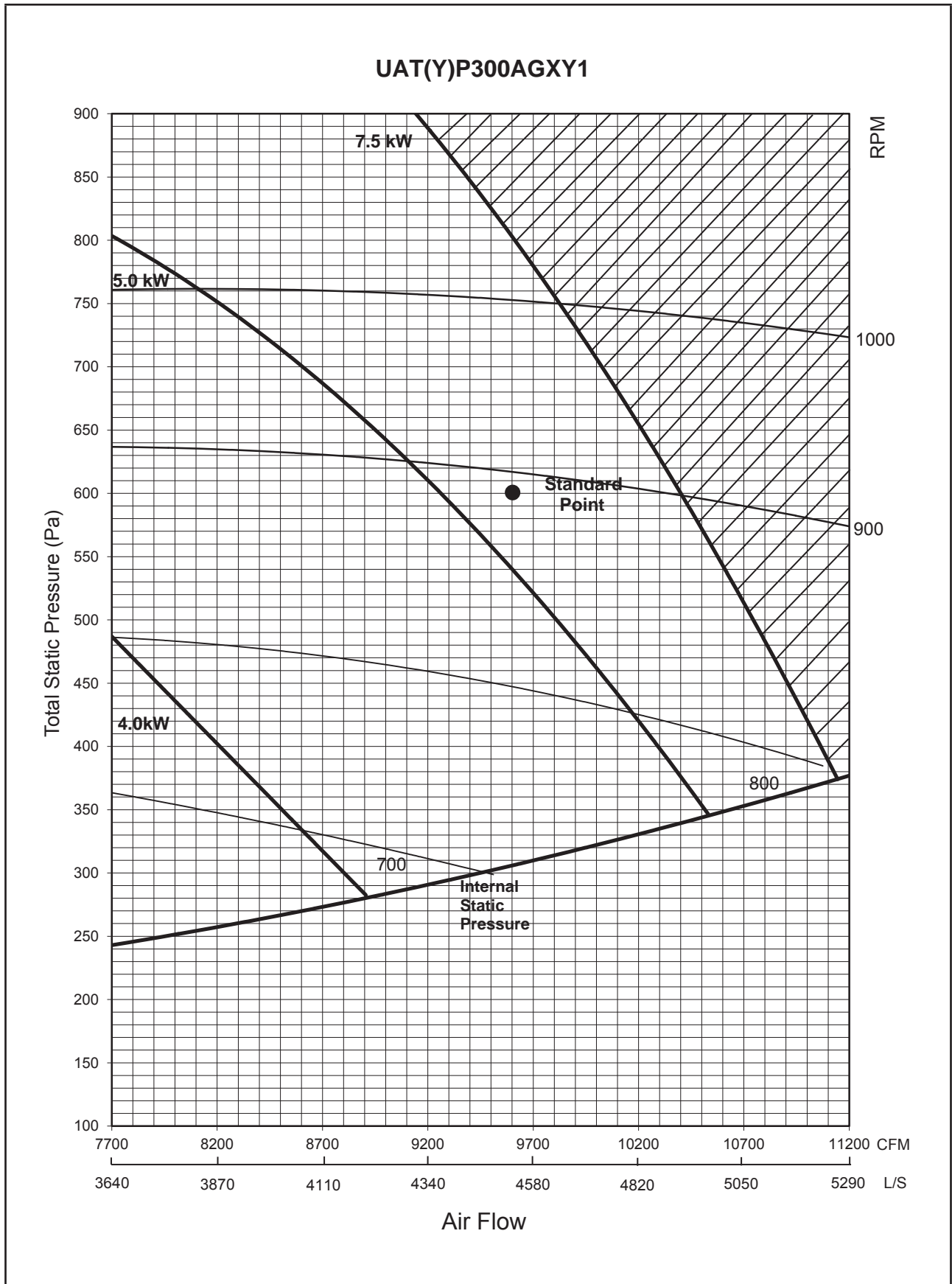

### UAT(Y)P360AGXY1

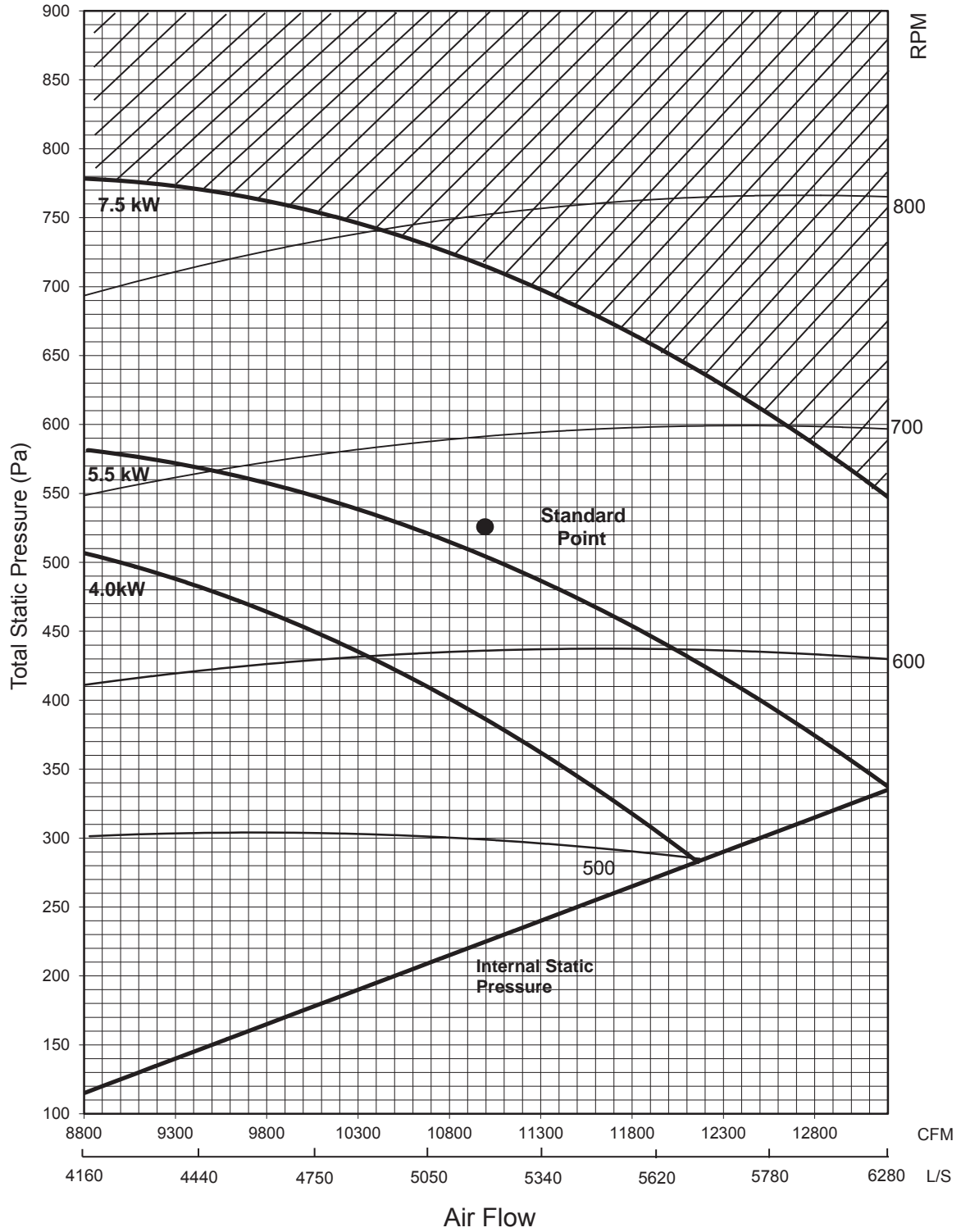

# Engineering & Physical Data

## Engineering Data – R407C COOLING MODEL

MODEL		UATP60AGXY1	UATP80AGXY1	UATP100AGXY1	UATP120AGXY1		
NOMINAL COOLING CAPACITY	Btu/h	59000	72000	95000	110000		
	W	17291	21101	27840	32238		
NOMINAL TOTAL INPUT POWER (COOLING)	W	5890	8700	11600	12180		
NOMINAL RUNNING CURRENT (COOLING)	A	10.90	16.30	20.20	22.80		
EER	W/W	2.94	2.43	2.40	2.65		
REFRIGERANT CONTROL (EXPANSION DEVICE)		TXV					
REFRIGERANT CHARGE	kg	4.60	4.60	5.90	5.60		
POWER SOURCE	V/Ph/Hz	380-415/3/50					
REFRIGERANT TYPE		R407C					
INDOOR UNIT	CONTROL		DUCTED				
	AIR DISCHARGE OPERATION		WIRED CONTROL				
	AIR FLOW	l/s / CFM	850 / 1800	1334 / 2826	1667 / 3532	1699 / 3600	
	EXTERNAL STATIC PRESSURE	Pa (in.wg.)	98 / 10	98	98	98	
	SOUND PRESSURE LEVEL	dBA	63	65	66	68	
	CONDENSATE DRAIN SIZE	mm	25.4				
	FAN	TYPE		CENTRIFUGAL			
		DRIVE		BELT DRIVE			
	FAN MOTOR	TYPE		INDUCTION MOTOR			
		INDEX OF PROTECTION (IP)		IP22			
		INSULATION GRADE		F			
		RATED INPUT POWER	W	470	1200	1900	1340
		RATED RUNNING CURRENT	A	1.49	2.10	2.70	2.59
	MOTOR MAX OUTPUT	W	750	1100	1500	1500	
	POLES		4	4	4	4	
	COIL	TUBE	MATERIAL	COPPER			
			DIAMETER	9.52			
		FIN	MATERIAL	ALUMINIUM	ALUMINIUM	ALUMINIUM	ALUMINIUM
			FACE AREA	0.53	0.65	0.65	0.63
	ROW		3	3	4	4	
AIR QUALITY	TYPE	SARANET					
QUANTITY	pc	1	1	1	2 + 4		
AIR FLOW	l/s / CFM	2124 / 4500	2667 / 5650	2667 / 5650	3776 / 8000		
SOUND PRESSURE LEVEL	dBA	63	65	66	68		
UNIT DIMENSION	HEIGHT X WIDTH X DEPTH	mm	1000 x 1100 x 1530	1000 x 1300 x 1530	1000 x 1300 x 1530	1000 x 1300 x 1530	
PACKING DIMENSION	HEIGHT X WIDTH X DEPTH	mm	1090 x 1250 x 1680	1090 x 1450 x 1680	1090 x 1450 x 1680	1090 x 1450 x 1680	
UNIT WEIGHT	kg	295	370	400	425		
OUTDOOR UNIT	FAN	TYPE		PROPELLER			
		DRIVE		DIRECT			
	FAN MOTOR	TYPE		INDUCTION MOTOR			
		INDEX OF PROTECTION (IP)		IP55			
		INSULATION GRADE		F			
		RATED INPUT POWER	W	590	670	670	960
		RATED RUNNING CURRENT	A	2.53	1.30	1.30	2.40
	MOTOR MAX OUTPUT	W	400	550	550	580	
	POLES		6	6	6	8	
	COMPRESSOR	TYPE		SCROLL			
		OIL TYPE		MINERAL OIL			
		OIL AMOUNT	cm <sup>3</sup>	1770	2510	3250	3250
		RATED INPUT POWER	W	4820	6830	9030	10220
		RATED RUNNING CURRENT	A	8.50	12.90	16.20	17.80
	LOCKED ROTOR AMP.	A	74	95	125	125	
	COIL	TUBE	MATERIAL	COPPER			
			DIAMETER	9.52			
		FIN	MATERIAL	ALUMINIUM	ALUMINIUM	ALUMINIUM	ALUMINIUM
			FACE AREA	1.42	1.40	1.38	1.38
	ROW		2	2	3	3	
CASING	COLOUR	LIGHT GREY					

ALL UNITS ARE BEING TESTED AND COMPLY TO ISO 5151 (NON-DUCTED UNIT) OR ISO 13253 (DUCTED UNIT).

COOLING	HEATING
INDOOR: 27°C DB/ 19°C WB	INDOOR: 20°C DB
OUTDOOR: 35°C DB/ 24°C WB	OUTDOOR: 8°C DB/ 6°C WB

## Engineering Data – R407C COOLING MODEL

MODEL				UATP150AGXY1	UATP200AGXY1	UATP250AGXY1	UATP300AGXY1
NOMINAL COOLING CAPACITY		Btu/h	140000	190000	230000	275000	
		W	41030	55684	67409	80600	
NOMINAL TOTAL INPUT POWER (COOLING)		W	17200	25100	28700	37850	
NOMINAL RUNNING CURRENT (COOLING)		A	32.10	43.80	53.00	65.80	
EER		W/W	2.39	2.22	2.20	2.13	
REFRIGERANT CONTROL (EXPANSION DEVICE)				TXV			
REFRIGERANT CHARGE		kg	3.90	4.20	9.60	10.4 / 10.4	
POWER SOURCE		V/Ph/Hz	380-415/3/50				
REFRIGERANT TYPE				R407C			
CONTROL		AIR DISCHARGE OPERATION	DUCTED				
			WIRED CONTROL				
AIR FLOW		l/s / CFM	2667 / 5651	3167 / 6710	3776 / 8000	4531 / 9600	
EXTERNAL STATIC PRESSURE		Pa (in.wg.)	196	196	294	294	
SOUND PRESSURE LEVEL		dBa	70	70	74	74	
CONDENSATE DRAIN SIZE		mm	25.4				
FAN		TYPE	CENTRIFUGAL				
		DRIVE	BELT DRIVE				
FAN MOTOR		TYPE	INDUCTION MOTOR				
		INDEX OF PROTECTION (IP)	IP22				
		INSULATION GRADE	F				
RATED INPUT POWER		W	2200	3500	4700	6900	
RATED RUNNING CURRENT		A	3.80	4.90	9.10	11.70	
MOTOR MAX OUTPUT		W	2200	3700	5500	7500	
POLES			4				
COIL		TUBE MATERIAL DIAMETER	COPPER				
		mm	9.52				
		FIN MATERIAL	ALUMINIUM	ALUMINIUM	ALUMINIUM	ALUMINIUM	
FACE AREA		m <sup>2</sup>	0.57	0.57	1.83	0.91	
ROW			3	4	4	4	
AIR QUALITY		FILTER TYPE	SARANET				
		QUANTITY	2	2	2	2	
AIR FLOW		l/s / CFM	5333 / 11300				
SOUND PRESSURE LEVEL		dBa	70	70	74	74	
UNIT DIMENSION		HEIGHT X WIDTH X DEPTH	1200 x 1990 x 1800	1200 x 1990 x 1800	1735 x 2250 x 2800	1735 x 2250 x 2800	
PACKING DIMENSION		HEIGHT X WIDTH X DEPTH	1320 x 2100 x 1810	1320 x 2100 x 1810	1900 x 2250 x 2900	1900 x 2250 x 2900	
UNIT WEIGHT		kg	665	765	1200	1350	
FAN		TYPE	PROPELLER				
		DRIVE	DIRECT				
FAN MOTOR		TYPE	INDUCTION MOTOR				
		INDEX OF PROTECTION (IP)	IP55				
		INSULATION GRADE	F				
RATED INPUT POWER		W	1280	1280	4200	1980	
RATED RUNNING CURRENT		A	2.7	2.7	7.2	3.4	
MOTOR MAX OUTPUT		W	550	550	1500	1500	
POLES			6	6	6	6	
COMPRESSOR		TYPE	SCROLL				
		OIL TYPE	MINERAL OIL				
OIL AMOUNT		cm <sup>3</sup>	2510	3250	3250	3253 & 3253	
RATED INPUT POWER		W	13720	20320	19800	27200	
RATED RUNNING CURRENT		A	25.60	36.20	36.70	47.40	
LOCKED ROTOR AMP.		A	95	125	125	174 & 174	
COIL		TUBE MATERIAL DIAMETER	COPPER				
		mm	9.52				
		FIN MATERIAL	ALUMINIUM	ALUMINIUM	ALUMINIUM	ALUMINIUM	
FACE AREA		m <sup>2</sup>	1.25	1.21	2.98	2.98	
ROW			2	3	2	2 & 2	
CASING		COLOUR	LIGHT GREY				

ALL UNITS ARE BEING TESTED AND COMPLY TO ISO 5151 (NON-DUCTED UNIT) OR ISO 13253 (DUCTED UNIT).

COOLING	HEATING
INDOOR: 27°C DB/ 19°C WB	INDOOR: 20°C DB
OUTDOOR: 35°C DB/ 24°C WB	OUTDOOR: 8°C DB/ 6°C WB

## Engineering Data – R407C COOLING MODEL

MODEL				UATP360AGXY1	UATP420AGXY1
NOMINAL COOLING CAPACITY		Btu/h	331000	415000	
		W	97007	121624	
NOMINAL TOTAL INPUT POWER (COOLING)		W	41870	48800	
NOMINAL RUNNING CURRENT (COOLING)		A	74.20	83.70	
EER		W/W	2.32	2.49	
REFRIGERANT CONTROL (EXPANSION DEVICE)				TXV	
REFRIGERANT CHARGE		kg	14.5 / 18.0	18.0 / 18.0	
POWER SOURCE		V/Ph/Hz	380-415/3/50		
REFRIGERANT TYPE				R407C	
INDOOR UNIT	CONTROL		DUCTED		
	AIR DISCHARGE OPERATION		WIRED CONTROL		
	AIR FLOW		l/s / CFM	5191 / 11000	5900 / 12500
	EXTERNAL STATIC PRESSURE		Pa (in.wg.)	294 / 30	294 / 30
	SOUND PRESSURE LEVEL		dBA	80	80
	CONDENSATE DRAIN SIZE		mm	25.4	
	FAN		CENTRIFUGAL		
	DRIVE		BELT DRIVE		
	FAN MOTOR		INDUCTION MOTOR		
	TYPE		F		
	INDEX OF PROTECTION (IP)		IP22		
	INSULATION GRADE		F		
	RATED INPUT POWER		W	5870	7500
	RATED RUNNING CURRENT		A	11.30	13.30
	MOTOR MAX OUTPUT		W	7500	7500
	POLES		4		
	COIL		COPPER		
	TUBE		MATERIAL	9.52	
			DIAMETER	mm	
	FIN		MATERIAL	ALUMINIUM	ALUMINIUM
		FACE AREA	3.02	3.02	
		ROW	3 & 4	4	
AIR QUALITY		SARANET			
FILTER		TYPE			
		QUANTITY	2 + 4	2 + 4	
OUTDOOR UNIT	AIR FLOW		l/s / CFM	20000	20000
	SOUND PRESSURE LEVEL		dBA	80	80
	UNIT DIMENSION		HEIGHT X WIDTH X DEPTH	1974 x 2252 x 3180	1974 x 2252 x 3180
	PACKING DIMENSION		HEIGHT X WIDTH X DEPTH	2150 x 2300 x 3250	2150 x 2300 x 3250
	UNIT WEIGHT		kg	1510	1600
	FAN		PROPELLER		
	DRIVE		DIRECT		
	FAN MOTOR		INDUCTION MOTOR		
	TYPE		IP55		
	INDEX OF PROTECTION (IP)		F		
	INSULATION GRADE		F		
	RATED INPUT POWER		W	4500	4500
	RATED RUNNING CURRENT		A	8.4	8.40
	MOTOR MAX OUTPUT		W	1250	1250
	POLES		6		
	COMPRESSOR		SCROLL		
	OIL TYPE		MINERAL OIL		
	OIL AMOUNT		cm <sup>3</sup>	6200 & 8000	8000
	RATED INPUT POWER		W	31500	36800
	RATED RUNNING CURRENT		A	54.50	62.00
LOCKED ROTOR AMP.		A	175 & 215	215 & 215	
COIL		COPPER			
TUBE		MATERIAL	9.52		
		DIAMETER	mm		
FIN		MATERIAL	ALUMINIUM	ALUMINIUM	
		FACE AREA	3.50	3.5	
		ROW	2 & 3	3	
CASING		COLOUR	LIGHT GREY		

ALL UNITS ARE BEING TESTED AND COMPLY TO ISO 5151 (NON-DUCTED UNIT) OR ISO 13253 (DUCTED UNIT).

COOLING	HEATING
INDOOR: 27°C DB/ 19°C WB	INDOOR: 20°C DB
OUTDOOR: 35°C DB/ 24°C WB	OUTDOOR: 8°C DB/ 6°C WB

ALL SPECIFICATIONS ARE SUBJECT TO CHANGE BY THE MANUFACTURER WITHOUT PRIOR NOTICE.

Standard for User Setting

## Engineering Data – R407C HEATPUMP MODEL

MODEL		UATYP60AGXY1	UATYP80AGXY1	UATYP100AGXY1	UATYP120AGXY1		
NOMINAL COOLING CAPACITY	Btu/h	56000	72000	88000	100000		
	W	16705	21101	25790	29307		
NOMINAL HEATING CAPACITY	Btu/h	56000	77000	102000	122000		
	W	16705	22566	29893	35755		
NOMINAL TOTAL INPUT POWER (COOLING)	W	6650	8410	10820	12810		
NOMINAL TOTAL INPUT POWER (HEATING)	W	6580	7540	9810	11260		
NOMINAL RUNNING CURRENT (COOLING)	A	13.2	16	20.6	23.20		
NOMINAL RUNNING CURRENT (HEATING)	A	12.9	15.4	19.3	21.20		
EER	W/W	2.47	2.51	2.38	2.29		
COP	W/W	3.07	2.99	3.05	3.17		
REFRIGERANT CONTROL (EXPANSION DEVICE)		TXV					
REFRIGERANT CHARGE	kg	4.30	5.20	6.00	6.00		
POWER SOURCE	V/Ph/Hz	380-415/3/50					
REFRIGERANT TYPE		R407C					
INDOOR UNIT	CONTROL OPERATION		DUCTED WIRED CONTROL				
	AIR FLOW	l/s / CFM	850 / 1800	1334 / 2826	3532	3600	
	EXTERNAL STATIC PRESSURE	Pa (in. wg.)	98 / 10	98 / 10	98 / 10	98 / 10	
	SOUND PRESSURE LEVEL	dBA	63	65	66	68	
	CONDENSATE DRAIN SIZE	mm	25.4				
	FAN	TYPE	CENTRIFUGAL				
		DRIVE	BELT DRIVE				
	FAN MOTOR	TYPE		INDUCTION MOTOR			
		INDEX OF PROTECTION (IP)		IP22			
		INSULATION GRADE		F			
		RATED INPUT POWER	W	650	810	1170	1340
		RATED RUNNING CURRENT	A	1.5	1.8	2.6	2.59
	MOTOR MAX OUTPUT	W	750	1100	1500	1500	
	POLES		4				
	COIL	TUBE	MATERIAL	COPPER			
			DIAMETER	9.52			
		FIN	MATERIAL	ALUMINIUM	ALUMINIUM	ALUMINIUM	ALUMINIUM
			FACE AREA	0.53	0.65	0.65	0.65
ROW		3	3	4	4		
AIR QUALITY	FILTER	SARANET					
	TYPE						
	QUANTITY	pc					
OUTDOOR UNIT	AIR FLOW	l/s / CFM	2124 / 4500	2667 / 5650	2667 / 5650	4719 / 10000	
	SOUND PRESSURE LEVEL	dBA	63	65	66	68	
	UNIT DIMENSION	HEIGHT X WIDTH X DEPTH	mm	1000 x 1100 x 1530	1000 x 1300 x 1530	1000 x 1300 x 1530	1000 x 1300 x 1530
	PACKING DIMENSION	HEIGHT X WIDTH X DEPTH	mm	1090 x 1250 x 1680	1090 x 1450 x 1680	1090 x 1450 x 1680	1090 x 1450 x 1680
	UNIT WEIGHT	kg	320	385	415	440	
	FAN	TYPE	PROPELLER				
		DRIVE	DIRECT				
	FAN MOTOR	TYPE		INDUCTION MOTOR			
		INDEX OF PROTECTION (IP)		IP55			
		INSULATION GRADE		F			
		RATED INPUT POWER	W	580 & 600	600	960	1600
		RATED RUNNING CURRENT	A	2.54 & 2.52	1.2	2.4	3.1
	MOTOR MAX OUTPUT	W	400	550	580	1250	
	POLES		6	6	8	6	
	COMPRESSOR	TYPE		SCROLL			
		OIL TYPE		MINERAL OIL			
		OIL AMOUNT	cm <sup>3</sup>	1770	2510	3250	3250
		RATED INPUT POWER	W	5670 & 5600	7000 & 6130	8700 & 7690	10210 & 8660
RATED RUNNING CURRENT		A	10.9 & 10.6	13.0 & 12.4	16.3 & 15.0	17.5 & 15.5	
LOCKED ROTOR AMP.	A	101	95	125	125		
COIL	TUBE	MATERIAL	COPPER				
		DIAMETER	9.52				
	FIN	MATERIAL	ALUMINIUM	ALUMINIUM	ALUMINIUM	ALUMINIUM	
		FACE AREA	1.39 & 1.42	1.39 & 1.41	1.38	1.38	
ROW		2	2	3	3		
CASING	COLOUR	LIGHT GREY					

ALL UNITS ARE BEING TESTED AND COMPLY TO ISO 5151 (NON-DUCTED UNIT) OR ISO 13253 (DUCTED UNIT).

COOLING	HEATING
INDOOR: 27°C DB/ 19°C WB	INDOOR: 20°C DB
OUTDOOR: 35°C DB/ 24°C WB	OUTDOOR: 8°C DB/ 6°C WB

ALL SPECIFICATIONS ARE SUBJECT TO CHANGE BY THE MANUFACTURER WITHOUT PRIOR NOTICE.

Standard for User Setting

## Engineering Data – R407C HEATPUMP MODEL

MODEL		UATYP150AGXY1	UATYP200AGXY1	UATYP250AGXY1	UATYP300AGXY1		
NOMINAL COOLING CAPACITY	Btu/h	149000	190000	230000	268200		
	W	43668	55684	67406	78600		
NOMINAL HEATING CAPACITY	Btu/h	160000	21160	255000	299500		
	W	46891	67406	74733	87780		
NOMINAL TOTAL INPUT POWER (COOLING)	W	16570	21160	29200	38160		
NOMINAL TOTAL INPUT POWER (HEATING)	W	15710	20300	26220	34780		
NOMINAL RUNNING CURRENT (COOLING)	A	32.2	34.7	52.1	65.50		
NOMINAL RUNNING CURRENT (HEATING)	A	31.2	33.2	48.6	61.90		
EER	W/W	2.75	2.63	2.30	2.07		
COP	W/W	3.12	3.32	2.73	2.55		
REFRIGERANT CONTROL (EXPANSION DEVICE)		TXV					
REFRIGERANT CHARGE	kg	2 x 5.0	2 x 5.8	2 x 9.4	2 x 9.6		
POWER SOURCE	V/Ph/Hz	380-415/3/50					
REFRIGERANT TYPE		R407C					
INDOOR UNIT	CONTROL OPERATION		DUCTED WIRED CONTROL				
	AIR FLOW	l/s / CFM	5651	6710	8000	9600	
	EXTERNAL STATIC PRESSURE	Pa (in.wg.)	196	196	294	294	
	SOUND PRESSURE LEVEL	dBA	70	70	74	74	
	CONDENSATE DRAIN SIZE	mm	25.4				
	FAN	TYPE		CENTRIFUGAL			
		DRIVE		BELT DRIVE			
	FAN MOTOR	TYPE		INDUCTION MOTOR			
		INDEX OF PROTECTION (IP)		IP22			
		INSULATION GRADE		F			
		RATED INPUT POWER	W	1650	2700	4700	6700
		RATED RUNNING CURRENT	A	3.5	5.2	9.1	11.7
	MOTOR MAX OUTPUT	W	2200	3700	5500	7500	
	POLES		4				
	COIL	TUBE	MATERIAL	COPPER			
DIAMETER			9.52				
FIN		MATERIAL	ALUMINIUM	ALUMINIUM	ALUMINIUM	ALUMINIUM	
		FACE AREA	0.57	0.57	1.83	1.83	
ROW		3	4	4	4		
AIR QUALITY	FILTER	SARANET					
	QUANTITY	2	2	2	2		
AIR FLOW		l/s / CFM	5333 / 11300	5333 / 11300	9439 / 20000	9439 / 20000	
SOUND PRESSURE LEVEL		dBA	70	70	74	74	
UNIT DIMENSION	HEIGHT X WIDTH X DEPTH	mm	1200 x 1990 x 1800	1200 x 1990 x 1800	1735 x 2250 x 2800	1735 x 2250 x 2800	
PACKING DIMENSION	HEIGHT X WIDTH X DEPTH	mm	1320 x 2100 x 1938	1320 x 2100 x 1938	1900 x 2250 x 2900	1900 x 2250 x 2900	
UNIT WEIGHT		kg	700	800	1200	1350	
OUTDOOR UNIT	FAN	TYPE		PROPELLER			
		DRIVE		DIRECT			
	FAN MOTOR	TYPE		INDUCTION MOTOR			
		INDEX OF PROTECTION (IP)		IP55			
		INSULATION GRADE		F			
		RATED INPUT POWER	W	1220	1280	4200	4200
		RATED RUNNING CURRENT	A	2.6	2.7	7.2	7.2
	MOTOR MAX OUTPUT	W	500	550	1500	1500	
	POLES		6	6	6	6	
	COMPRESSOR	TYPE		SCROLL			
		OIL TYPE		MINERAL OIL			
		OIL AMOUNT	cm <sup>3</sup>	2510	3250	3250	4140
		RATED INPUT POWER	W	13700 & 12840	17180 & 16320	20300 & 17320	27260 & 23880
		RATED RUNNING CURRENT	A	26.1 & 25.1	32 & 30.5	35.8 & 32.3	46.6 & 43.0
	LOCKED ROTOR AMP.	A	95	125	125	198	
COIL	TUBE	MATERIAL	COPPER				
		DIAMETER	9.52				
	FIN	MATERIAL	ALUMINIUM	ALUMINIUM	ALUMINIUM	ALUMINIUM	
		FACE AREA	1.34 & 1.37	1.3 & 1.33 & 1.36	2.98	2.98	
ROW		2	3	2	2		
CASING	COLOUR	LIGHT GREY					

ALL UNITS ARE BEING TESTED AND COMPLY TO ISO 5151 (NON-DUCTED UNIT) OR ISO 13253 (DUCTED UNIT).

COOLING	HEATING
INDOOR: 27°C DB/ 19°C WB	INDOOR: 20°C DB
OUTDOOR: 35°C DB/ 24°C WB	OUTDOOR: 8°C DB/ 6°C WB

ALL SPECIFICATIONS ARE SUBJECT TO CHANGE BY THE MANUFACTURER WITHOUT PRIOR NOTICE.

Standard for User Setting

## Engineering Data – R407C HEATPUMP MODEL

MODEL			UATYP360AGXY1	UATYP420AGXY1	
NOMINAL COOLING CAPACITY	Btu/h		345000	374000	
	W		101110	109609	
NOMINAL HEATING CAPACITY	Btu/h		349000	431000	
	W		102290	126314	
NOMINAL TOTAL INPUT POWER (COOLING)	W		43170	48200	
NOMINAL TOTAL INPUT POWER (HEATING)	W		41670	46800	
NOMINAL RUNNING CURRENT (COOLING)	A		74.2	82.9	
NOMINAL RUNNING CURRENT (HEATING)	A		72	81.1	
EER	W/W		2.34	2.27	
COP	W/W		2.45	2.70	
REFRIGERANT CONTROL (EXPANSION DEVICE)			TXV		
REFRIGERANT CHARGE			13.5 / 20	20 x 2	
POWER SOURCE			V/Ph/Hz 380-415/3/50		
REFRIGERANT TYPE			R407C		
INDOOR UNIT	CONTROL OPERATION	AIR DISCHARGE			
		DUCTED			
	WIRED CONTROL				
	AIR FLOW	l/s / CFM	11000	12500	
	EXTERNAL STATIC PRESSURE	Pa (in.wg.)	294	294	
	SOUND PRESSURE LEVEL	dBA	80	80	
	CONDENSATE DRAIN SIZE	mm	25.4		
	FAN DRIVE	TYPE			
		CENTRIFUGAL			
	FAN MOTOR	TYPE			
		INDUCTION MOTOR			
	FAN MOTOR	INDEX OF PROTECTION (IP)			
		IP22			
	FAN MOTOR	INSULATION GRADE			
		F			
	FAN MOTOR	RATED INPUT POWER	W	5870	7500
		RATED RUNNING CURRENT	A	11.3	13.3
	FAN MOTOR	MOTOR MAX OUTPUT	W	5107	6525
		POLES			
				4	
COIL	TUBE	MATERIAL	COPPER		
		DIAMETER	9.52		
	FIN	MATERIAL	ALUMINIUM	ALUMINIUM	
		FACE AREA	1.56 & 1.47	1.55 & 1.47	
COIL	ROW	3 & 4			
	ROW	4			
AIR QUALITY FILTER	TYPE				
	SARANET				
AIR QUALITY FILTER	QUANTITY	pc	2 + 4	2 + 4	
OUTDOOR UNIT	AIR FLOW	l/s / CFM	9439 / 20000	9439 / 20000	
	SOUND PRESSURE LEVEL	dBA	80	80	
	UNIT DIMENSION	HEIGHT X WIDTH X DEPTH	mm	1974 x 2252 x 3180	1974 x 2252 x 3180
	PACKING DIMENSION	HEIGHT X WIDTH X DEPTH	mm	2150 x 2300 x 3250	2150 x 2300 x 3250
	UNIT WEIGHT	kg	1510	1600	
	FAN DRIVE	TYPE			
		PROPELLER			
	FAN MOTOR	TYPE			
		INDUCTION MOTOR			
	FAN MOTOR	INDEX OF PROTECTION (IP)			
		IP55			
	FAN MOTOR	INSULATION GRADE			
		F			
	FAN MOTOR	RATED INPUT POWER	W	4500	4500
		RATED RUNNING CURRENT	A	8.4	8.4
	FAN MOTOR	MOTOR MAX OUTPUT	W	3465	3465
		POLES			
				6	
	COMPRESSOR	TYPE			
		SCROLL			
COMPRESSOR	OIL TYPE				
	MINERAL OIL				
COMPRESSOR	OIL AMOUNT	cm <sup>3</sup>	8000	8000	
	RATED INPUT POWER	W	32800 & 31300	36200 & 34800	
COMPRESSOR	RATED RUNNING CURRENT	A	54.50 & 52.30	61.20 & 59.40	
	LOCKED ROTOR AMP.	A	215	215	
COIL	TUBE	MATERIAL	COPPER		
		DIAMETER	9.52		
	FIN	MATERIAL	ALUMINIUM	ALUMINIUM	
		FACE AREA	3.5	3.5	
COIL	ROW	2 & 3			
	ROW	3			
CASING	COLOUR	LIGHT GREY			

ALL UNITS ARE BEING TESTED AND COMPLY TO ISO 5151 (NON-DUCTED UNIT) OR ISO 13253 (DUCTED UNIT).

COOLING	HEATING
INDOOR: 27°C DB/ 19°C WB	INDOOR: 20°C DB
OUTDOOR: 35°C DB/ 24°C WB	OUTDOOR: 8°C DB/ 6°C WB

ALL SPECIFICATIONS ARE SUBJECT TO CHANGE BY THE MANUFACTURER WITHOUT PRIOR NOTICE.

Standard for User Setting

## Safety Devices (R407C)

MODEL			UATP60AGXY1	UATP80AGXY1
SAFETY DEVICE	HIGH PRESSURE SWITCH	TYPE	NC	
		OPEN	kPa/psi	3241 / 470
		CLOSE	kPa/psi	2648 / 384
	LOW PRESSURE SWITCH	TYPE	N/A	
		OPEN	kPa/psi	N/A
		CLOSE	kPa/psi	N/A
	PHASE SEQUENCER			N/A
DISCHARGE THERMOSTAT SETTING		°C / °F	125 / 257	

MODEL			UATP100AGXY1	UATP120AGXY1
SAFETY DEVICE	HIGH PRESSURE SWITCH	TYPE	NC	
		OPEN	kPa/psi	3241 / 470
		CLOSE	kPa/psi	2648 / 384
	LOW PRESSURE SWITCH	TYPE	N/A	
		OPEN	kPa/psi	N/A
		CLOSE	kPa/psi	N/A
	PHASE SEQUENCER			N/A
DISCHARGE THERMOSTAT SETTING		°C / °F	125 / 257	

MODEL			UATP150AGXY1	UATP200AGXY1
SAFETY DEVICE	HIGH PRESSURE SWITCH	TYPE	NC	
		OPEN	kPa/psi	3241 / 470
		CLOSE	kPa/psi	2648 / 384
	LOW PRESSURE SWITCH	TYPE	N/A	
		OPEN	kPa/psi	N/A
		CLOSE	kPa/psi	N/A
	PHASE SEQUENCER			YES
DISCHARGE THERMOSTAT SETTING		°C / °F	N/A	

MODEL			UATP250AGXY1	UATP300AGXY1
SAFETY DEVICE	HIGH PRESSURE SWITCH	TYPE	NC	
		OPEN	kPa/psi	3241 / 470
		CLOSE	kPa/psi	2648 / 384
	LOW PRESSURE SWITCH	TYPE	N/A	
		OPEN	kPa/psi	N/A
		CLOSE	kPa/psi	N/A
	PHASE SEQUENCER			YES
DISCHARGE THERMOSTAT SETTING		°C / °F	N/A	

1) ALL SPECIFICATIONS ARE SUBJECTED TO CHANGE BY THE MANUFACTURER WITHOUT PRIOR NOTICE.

## Safety Devices (R407C)

MODEL			UATP360AGXY1	UATP420AGXY1
SAFETY DEVICE	HIGH PRESSURE SWITCH	TYPE	NC	
		OPEN	kPa/psi	3241 / 470
		CLOSE	kPa/psi	2648 / 384
	LOW PRESSURE SWITCH	TYPE	N/A	
		OPEN	kPa/psi	N/A
		CLOSE	kPa/psi	N/A
	PHASE SEQUENCER			YES
DISCHARGE THERMOSTAT SETTING		°C / °F	N/A	

MODEL			UATYP60AGXY1	UATYP80AGXY1
SAFETY DEVICE	HIGH PRESSURE SWITCH	TYPE	NC	
		OPEN	kPa/psi	3241 / 470
		CLOSE	kPa/psi	2648 / 384
	LOW PRESSURE SWITCH	TYPE	N/A	
		OPEN	kPa/psi	N/A
		CLOSE	kPa/psi	N/A
	PHASE SEQUENCER			YES
DISCHARGE THERMOSTAT SETTING		°C / °F	125 / 257	

MODEL			UATYP100AGXY1	UATYP120AGXY1
SAFETY DEVICE	HIGH PRESSURE SWITCH	TYPE	NC	
		OPEN	kPa/psi	3241 / 470
		CLOSE	kPa/psi	2648 / 384
	LOW PRESSURE SWITCH	TYPE	N/A	
		OPEN	kPa/psi	N/A
		CLOSE	kPa/psi	N/A
	PHASE SEQUENCER			YES
DISCHARGE THERMOSTAT SETTING		°C / °F	125 / 257	

MODEL			UATYP150AGXY1	UATYP200AGXY1
SAFETY DEVICE	HIGH PRESSURE SWITCH	TYPE	NC	
		OPEN	kPa/psi	3241 / 470
		CLOSE	kPa/psi	2648 / 384
	LOW PRESSURE SWITCH	TYPE	N/A	
		OPEN	kPa/psi	N/A
		CLOSE	kPa/psi	N/A
	PHASE SEQUENCER			YES
DISCHARGE THERMOSTAT SETTING		°C / °F	N/A	

1) ALL SPECIFICATIONS ARE SUBJECTED TO CHANGE BY THE MANUFACTURER WITHOUT PRIOR NOTICE.

**Safety Devices (R407C)**

MODEL			UATYP250AGXY1	UATYP300AGXY1
SAFETY DEVICE	HIGH PRESSURE SWITCH	TYPE	NC	
		OPEN	kPa/psi	3241 / 470
		CLOSE	kPa/psi	2648 / 384
	LOW PRESSURE SWITCH	TYPE	N/A	
		OPEN	kPa/psi	N/A
		CLOSE	kPa/psi	N/A
	PHASE SEQUENCER			YES
DISCHARGE THERMOSTAT SETTING		°C / °F	N/A	

MODEL			UATYP360AGXY1	UATYP420AGXY1
SAFETY DEVICE	HIGH PRESSURE SWITCH	TYPE	NC	
		OPEN	kPa/psi	3241 / 470
		CLOSE	kPa/psi	2648 / 384
	LOW PRESSURE SWITCH	TYPE	N/A	
		OPEN	kPa/psi	N/A
		CLOSE	kPa/psi	N/A
	PHASE SEQUENCER			YES
DISCHARGE THERMOSTAT SETTING		°C / °F	N/A	

1) ALL SPECIFICATIONS ARE SUBJECTED TO CHANGE BY THE MANUFACTURER WITHOUT PRIOR NOTICE.

# Performance Data

## Calculation Steps

Interpolation method can be used to get the total capacity, TC and sensible capacity, SC and power input, PI at those temperatures which are not stated out in the table. Extrapolation method are not allowed to be used to get the TC, SC and PI.

### Example:

**Model:** UATP200AGXY1

**Indoor Condition:** 25°C DB, 17°C WB

**Outdoor Condition:** 37°C DB

**Fan Speed:** High (6710CFM)

### Solution:

#### Overall

Based on the Performance Table

1. Refer to the Indoor DB column,
  - **25°C** is located between 24°C and 27°C for 16°CWB (Thus, Interpolation need to be applied)
  - **25°C** is located between 24°C and 27°C for 19°CWB (Thus, Interpolation need to be applied)
2. Refer to the Indoor WB column,
  - **17°C** is located between 16°CWB and 19°CWB for 25°CDB (Thus, Interpolation need to be applied)
3. Refer to the Outdoor DB column,
  - **37°C** is located between 35°C and 40°C. (Thus, Interpolation need to be applied)

Please follow the steps below in order to get the required capacity.

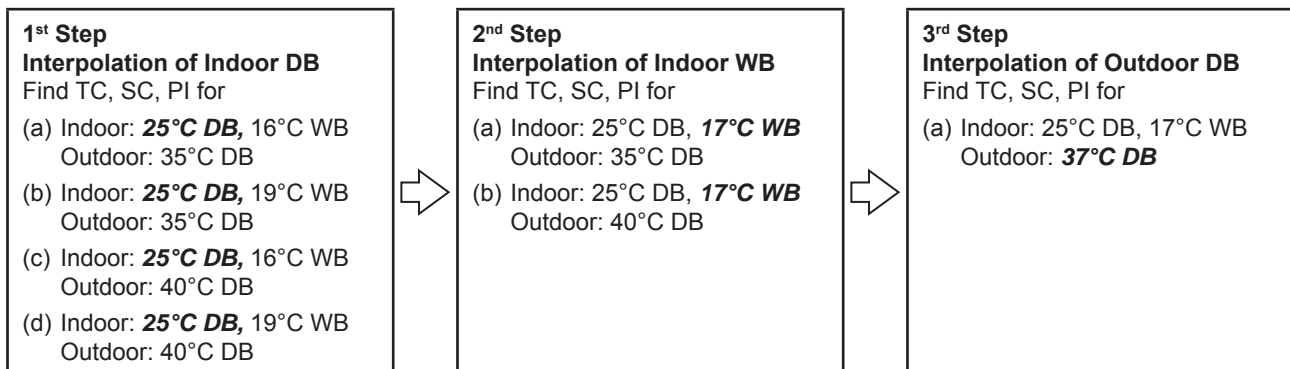

**Details:****1<sup>st</sup> Step:**

To obtain the Total capacity and Sensible capacity and Power input for

**(a) Indoor Condition: 25°C DB, 16°C WB**

**Outdoor Condition: 35°C DB**

Indoor WB °C	Indoor DB °C	Outdoor DB, °C			
		35			
		TC (kW)	SHC (kW)	PI (kW)	
16					
	24	53.36	47.36	20.24	
	25	-----	$x_1$	$y_1$	$z_1$
	27	54.44	54.22	20.33	

Total capacity, TC

Interpolation Method:

$$\Rightarrow \frac{27^\circ \text{C} - 24^\circ \text{C}}{27^\circ \text{C} - 25^\circ \text{C}} = \frac{54.44\text{kW} - 53.36\text{kW}}{54.44\text{kW} - x_1\text{kW}}$$

$$\Rightarrow x_1 = 53.72\text{kW}$$

Sensible capacity, SHC

Interpolation Method:

$$\Rightarrow \frac{27^\circ \text{C} - 24^\circ \text{C}}{27^\circ \text{C} - 25^\circ \text{C}} = \frac{54.22\text{kW} - 47.36\text{kW}}{54.22\text{kW} - y_1\text{kW}}$$

$$\Rightarrow y_1 = 49.65\text{kW}$$

Power Input, PI

Interpolation Method:

$$\Rightarrow \frac{27^\circ \text{C} - 24^\circ \text{C}}{27^\circ \text{C} - 25^\circ \text{C}} = \frac{20.33\text{kW} - 20.24\text{kW}}{20.33\text{kW} - z_1\text{kW}}$$

$$\Rightarrow z_1 = 20.27\text{kW}$$

**(b) Indoor Condition: 25°C DB, 16°C WB****Outdoor Condition: 40°C DB**

Indoor WB °C	Indoor DB °C	Outdoor DB, °C		
		40		
		TC (kW)	SHC (kW)	PI (kW)
16	24	48.02	43.38	21.89
	25	-----	$y_2$	$z_2$
	27	49.37	49.37	22.02

Total capacity, TC

Interpolation Method:

$$\Rightarrow \frac{27^\circ \text{C} - 24^\circ \text{C}}{27^\circ \text{C} - 25^\circ \text{C}} = \frac{49.37\text{kW} - 48.02\text{kW}}{49.37\text{kW} - x_2\text{kW}}$$

$$\Rightarrow x_2 = 48.47\text{kW}$$

Sensible capacity, SHC

Interpolation Method:

$$\Rightarrow \frac{27^\circ \text{C} - 24^\circ \text{C}}{27^\circ \text{C} - 25^\circ \text{C}} = \frac{49.37\text{kW} - 43.38\text{kW}}{49.37\text{kW} - y_2\text{kW}}$$

$$\Rightarrow y_2 = 45.38\text{kW}$$

Power Input, PI

Interpolation Method:

$$\Rightarrow \frac{27^\circ \text{C} - 24^\circ \text{C}}{27^\circ \text{C} - 25^\circ \text{C}} = \frac{22.02\text{kW} - 21.89\text{kW}}{22.02\text{kW} - z_2\text{kW}}$$

$$\Rightarrow z_2 = 21.93\text{kW}$$

**\* Repeat process (a) and (b) in 1st step for the condition below:****(c) Indoor Condition: 25°C DB, 19°C WB****Outdoor Condition: 35°C DB**

$$\Rightarrow x_3 = 58.42\text{kW}$$

$$\Rightarrow y_3 = 39.60\text{kW}$$

$$\Rightarrow z_3 = 20.69\text{kW}$$

**(d) Indoor Condition: 25°C DB, 19°C WB****Outdoor Condition: 40°C DB**

$$\Rightarrow x_4 = 52.61\text{kW}$$

$$\Rightarrow y_4 = 36.24\text{kW}$$

$$\Rightarrow z_4 = 22.35\text{kW}$$

**2<sup>nd</sup> Step:**

To obtain the Total capacity, Sensible capacity and Power Input for

**(a) Indoor Condition: 25°C DB, 17°C WB**

**Outdoor Condition: 35°C DB**

Indoor WB °C	Indoor DB °C	Outdoor DB, °C			
			35		
			TC (kW)	SHC (kW)	PI (kW)
			∣	∣	
16	25		53.72	49.65	20.27
17		-----	$x_5$	$y_5$	$z_5$
19			58.42	39.60	20.69

Total capacity, TC

Interpolation Method:

$$\Rightarrow \frac{19^\circ\text{C} - 16^\circ\text{C}}{19^\circ\text{C} - 17^\circ\text{C}} = \frac{58.42\text{kW} - 53.72\text{kW}}{58.42\text{kW} - x_5\text{kW}}$$

$$\Rightarrow x_5 = 55.29\text{kW}$$

Sensible capacity, SHC

Interpolation Method:

$$\Rightarrow \frac{19^\circ\text{C} - 16^\circ\text{C}}{19^\circ\text{C} - 17^\circ\text{C}} = \frac{39.60\text{kW} - 49.65\text{kW}}{39.60\text{kW} - y_5\text{kW}}$$

$$\Rightarrow y_5 = 46.30\text{kW}$$

Power Input, PI

Interpolation Method:

$$\Rightarrow \frac{19^\circ\text{C} - 16^\circ\text{C}}{19^\circ\text{C} - 17^\circ\text{C}} = \frac{20.69\text{kW} - 20.27\text{kW}}{20.69\text{kW} - z_5\text{kW}}$$

$$\Rightarrow z_5 = 20.41\text{kW}$$

(b) Indoor Condition: 25°C DB, 17°C WB

Outdoor Condition: 40°C DB

Indoor WB °C	Indoor DB °C	Outdoor DB, °C		
		40		
		TC (kW)	SHC (kW)	PI (kW)
		↓	↓	
16	25	48.47	45.38	21.93
17		----- $x_6$	$y_6$	$z_6$
19		52.61	36.24	22.35

Total capacity, TC

Interpolation Method:

$$\Rightarrow \frac{19^\circ\text{C} - 16^\circ\text{C}}{19^\circ\text{C} - 17^\circ\text{C}} = \frac{52.61\text{kW} - 48.47\text{kW}}{52.61\text{kW} - x_6\text{kW}}$$

$$\Rightarrow x_6 = 49.85\text{kW}$$

Sensible capacity, SHC

Interpolation Method:

$$\Rightarrow \frac{19^\circ\text{C} - 16^\circ\text{C}}{19^\circ\text{C} - 17^\circ\text{C}} = \frac{36.24\text{kW} - 45.38\text{kW}}{36.24\text{kW} - y_6\text{kW}}$$

$$\Rightarrow y_6 = 42.33\text{kW}$$

Power Input, PI

Interpolation Method:

$$\Rightarrow \frac{19^\circ\text{C} - 16^\circ\text{C}}{19^\circ\text{C} - 17^\circ\text{C}} = \frac{22.35\text{kW} - 21.93\text{kW}}{22.35\text{kW} - z_6\text{kW}}$$

$$\Rightarrow z_6 = 22.07\text{kW}$$

**3<sup>rd</sup> Step:**

To obtain the Total capacity and Sensible capacity for

**(a) Indoor Condition: 25°C DB, 17°C WB**

**Outdoor Condition: 37°C DB**

Indoor WB °C	Indoor DB °C	Outdoor DB, °C									
			35			37			40		
			TC (kW)	SHC (kW)	PI (kW)	TC (kW)	SHC (kW)	PI (kW)	TC (kW)	SHC (kW)	PI (kW)
25	17	-----	55.29	46.30	20.41	x	y	z	49.85	42.33	22.07

Total capacity, TC

Interpolation Method:

$$\Rightarrow \frac{40^{\circ}\text{C} - 35^{\circ}\text{C}}{40^{\circ}\text{C} - 37^{\circ}\text{C}} = \frac{49.85\text{kW} - 55.29\text{kW}}{49.85\text{kW} - x\text{kW}}$$

$$\Rightarrow x = 53.11\text{kW}$$

Sensible capacity, SHC

Interpolation Method:

$$\Rightarrow \frac{40^{\circ}\text{C} - 35^{\circ}\text{C}}{40^{\circ}\text{C} - 37^{\circ}\text{C}} = \frac{42.33\text{kW} - 46.30\text{kW}}{42.33\text{kW} - y\text{kW}}$$

$$\Rightarrow y = 44.71\text{kW}$$

Power Input, PI

Interpolation Method:

$$\Rightarrow \frac{40^{\circ}\text{C} - 35^{\circ}\text{C}}{40^{\circ}\text{C} - 37^{\circ}\text{C}} = \frac{22.07\text{kW} - 20.41\text{kW}}{22.07\text{kW} - z\text{kW}}$$

$$\Rightarrow z = 21.07\text{kW}$$

## Performance Tables

### R407C Cooling Only

Model: UATP60AGXY1

Cooling Mode

AFR (CFM)	EWB	EDB	Outdoor temperature																	
			19°C			25°C			30°C			35°C			40°C			46°C		
			TC	SC	PI	TC	SC	PI	TC	SC	PI	TC	SC	PI	TC	SC	PI	TC	SC	PI
1620	16°C	21°C	17.09	11.25	4.62	16.54	11.00	4.94	15.97	10.74	5.31	15.35	10.46	5.73	13.81	9.55	6.20	12.83	9.03	6.82
		24°C	17.15	13.40	4.62	16.61	13.12	4.94	16.04	12.82	5.31	15.42	12.51	5.73	13.89	11.45	6.20	12.90	10.88	6.83
		27°C	17.22	15.42	4.63	16.69	15.13	4.95	16.13	14.82	5.32	15.56	14.44	5.74	14.08	13.15	6.22	13.22	12.35	6.86
		30°C	17.90	17.90	4.68	17.45	17.45	5.00	16.96	16.96	5.38	16.44	16.44	5.82	14.94	14.94	6.30	14.04	14.04	6.95
	19°C	24°C	18.77	10.63	4.74	18.19	10.40	5.06	17.56	10.15	5.43	16.90	9.89	5.86	15.22	9.04	6.33	14.16	8.58	6.96
		27°C	18.82	12.41	4.74	18.23	12.16	5.06	17.61	11.89	5.44	16.95	11.61	5.86	15.28	10.63	6.33	14.22	10.11	6.97
		30°C	18.89	15.15	4.74	18.30	14.87	5.07	17.67	14.59	5.44	17.00	14.28	5.87	15.33	13.13	6.34	14.27	12.55	6.97
		33°C	19.00	19.00	4.75	18.46	18.46	5.08	17.92	17.92	5.46	17.38	17.38	5.90	15.81	15.81	6.39	14.89	14.89	7.04
	22°C	27°C	20.60	9.98	4.87	19.95	9.76	5.19	19.27	9.54	5.57	18.55	9.30	6.00	16.73	8.51	6.48	15.58	8.08	7.11
		30°C	20.63	12.34	4.87	19.98	12.10	5.20	19.30	11.84	5.58	18.59	11.57	6.00	16.77	10.60	6.48	15.62	10.10	7.12
		33°C	20.68	14.38	4.87	20.04	14.12	5.20	19.36	13.86	5.58	18.65	13.58	6.01	16.82	12.49	6.49	15.68	11.95	7.12
		36°C	20.74	16.37	4.88	20.10	16.12	5.21	19.41	15.84	5.59	18.70	15.56	6.02	16.89	14.34	6.49	15.81	13.66	7.14
1800	16°C	21°C	17.45	11.70	4.65	16.89	11.45	4.96	16.28	11.18	5.33	15.65	10.87	5.75	14.08	9.92	6.22	13.07	9.37	6.85
		24°C	17.54	13.95	4.65	16.98	13.66	4.97	16.38	13.36	5.34	15.74	13.04	5.76	14.17	11.95	6.23	13.15	11.36	6.86
		27°C	17.66	16.17	4.66	17.13	15.82	4.98	16.60	15.41	5.36	16.06	14.93	5.79	14.57	13.61	6.27	13.67	12.80	6.91
		30°C	18.57	18.57	4.72	18.10	18.10	5.05	17.58	17.58	5.43	17.03	17.03	5.87	15.47	15.47	6.35	14.53	14.53	7.00
	19°C	24°C	19.15	11.04	4.76	18.55	10.81	5.09	17.90	10.56	5.46	17.21	10.30	5.88	15.50	9.43	6.36	14.41	8.95	6.99
		27°C	19.23	12.93	4.77	18.62	12.67	5.09	17.97	12.39	5.47	17.29	12.10	5.89	15.57	11.09	6.36	14.48	10.56	6.99
		30°C	19.31	15.86	4.77	18.70	15.58	5.10	18.04	15.28	5.47	17.37	14.98	5.90	15.66	13.77	6.37	14.60	13.09	7.01
		33°C	19.62	19.62	4.80	19.12	19.12	5.13	18.59	18.59	5.52	18.02	18.02	5.95	16.38	16.38	6.44	15.42	15.42	7.10
	22°C	27°C	20.99	10.37	4.89	20.32	10.15	5.22	19.62	9.92	5.60	18.88	9.68	6.03	17.02	8.87	6.51	15.84	8.44	7.14
		30°C	21.04	12.88	4.90	20.37	12.62	5.23	19.67	12.35	5.61	18.94	12.07	6.04	17.08	11.07	6.51	15.90	10.56	7.15
		33°C	21.12	15.06	4.90	20.46	14.80	5.24	19.75	14.52	5.61	19.01	14.24	6.04	17.14	13.10	6.52	15.97	12.55	7.16
		36°C	21.20	17.22	4.91	20.53	16.95	5.24	19.83	16.65	5.62	19.15	16.30	6.06	17.35	15.07	6.54	16.32	14.36	7.20
1980	16°C	21°C	17.75	12.02	4.67	17.17	11.74	4.98	16.56	11.44	5.35	15.91	11.13	5.77	14.31	10.15	6.24	13.27	9.59	6.87
		24°C	17.87	14.32	4.67	17.29	14.04	4.99	16.67	13.73	5.36	16.02	13.41	5.78	14.40	12.28	6.25	13.36	11.69	6.88
		27°C	18.12	16.69	4.69	17.61	16.42	5.02	17.10	16.10	5.40	16.54	15.73	5.83	14.99	14.30	6.31	14.06	13.48	6.95
		30°C	19.17	19.17	4.76	18.66	18.66	5.10	18.13	18.13	5.48	17.55	17.55	5.91	15.93	15.93	6.40	14.96	14.96	7.05
	19°C	24°C	19.47	11.56	4.79	18.85	11.32	5.11	18.18	11.07	5.48	17.47	10.80	5.91	15.73	9.87	6.38	14.62	9.35	7.01
		27°C	19.57	13.53	4.79	18.95	13.26	5.12	18.28	12.98	5.49	17.57	12.68	5.92	15.82	11.63	6.39	14.70	11.08	7.02
		30°C	19.68	16.67	4.80	19.03	16.38	5.13	18.38	16.07	5.50	17.69	15.73	5.93	15.99	14.38	6.41	14.97	13.58	7.05
		33°C	20.25	20.25	4.84	19.73	19.73	5.18	19.18	19.18	5.57	18.59	18.59	6.01	16.89	16.89	6.49	15.89	15.89	7.15
	22°C	27°C	21.33	10.85	4.92	20.64	10.62	5.25	19.91	10.39	5.63	19.15	10.16	6.06	17.26	9.31	6.53	16.06	8.86	7.17
		30°C	21.40	13.49	4.92	20.71	13.22	5.25	19.99	12.95	5.63	19.24	12.66	6.06	17.34	11.62	6.54	16.14	11.08	7.17
		33°C	21.50	15.84	4.93	20.81	15.57	5.26	20.08	15.29	5.64	19.32	15.00	6.07	17.41	13.81	6.55	16.21	13.24	7.18
		36°C	21.61	18.14	4.94	20.96	17.81	5.27	20.30	17.42	5.66	19.64	16.96	6.10	17.86	15.60	6.59	16.82	14.81	7.25

**Remark:**

AFR: Air flow rate (CFM)  
 EWB: Entering Wet Bulb Temp. (°C)  
 EDB: Entering Dry Bulb Temp. (°C)  
 TC: Total Cooling Capacity (kW)  
 SC: Sensible Cooling Capacity (kW)  
 PI: Power Input (kW)

**Notes:**

1. Ratings shown are net capacities.
2. ■ shows nominal capacities.
3. Direct interpolation is permissible. Do not extrapolate.
4. Unit is able to operate at ambient from 19°C to 46°C DB without pressure trip.

**Model: UATP80AGXY1**

**Cooling Mode**

AFR (CFM)	EWB	EDB	Outdoor temperature																	
			19°C			25°C			30°C			35°C			40°C			46°C		
			TC	SC	PI	TC	SC	PI	TC	SC	PI	TC	SC	PI	TC	SC	PI	TC	SC	PI
2543	16°C	21°C	20.85	14.51	6.82	20.19	14.19	7.29	19.49	13.85	7.84	18.73	13.49	8.46	16.86	12.32	9.15	15.66	11.65	10.08
		24°C	20.93	17.28	6.83	20.27	16.92	7.30	19.57	16.54	7.85	18.82	16.14	8.47	16.95	14.77	9.16	15.74	14.04	10.09
		27°C	21.01	19.90	6.84	20.37	19.52	7.31	19.68	19.12	7.86	18.99	18.63	8.48	17.19	16.96	9.19	16.13	15.93	10.14
		30°C	21.84	21.84	6.91	21.29	21.29	7.39	20.70	20.70	7.95	20.07	20.07	8.59	18.23	18.23	9.31	17.14	17.14	10.26
	19°C	24°C	22.91	13.71	7.00	22.20	13.41	7.47	21.43	13.09	8.02	20.62	12.76	8.65	18.58	11.66	9.35	17.27	11.07	10.28
		27°C	22.97	16.01	7.00	22.25	15.69	7.48	21.49	15.34	8.03	20.69	14.97	8.66	18.65	13.71	9.36	17.35	13.05	10.29
		30°C	23.06	19.54	7.01	22.33	19.19	7.49	21.56	18.82	8.04	20.75	18.42	8.67	18.71	16.94	9.37	17.42	16.19	10.30
		33°C	23.19	23.19	7.02	22.53	22.53	7.50	21.87	21.87	8.07	21.21	21.21	8.71	19.29	19.29	9.44	18.17	18.17	10.40
	22°C	27°C	25.14	12.88	7.19	24.34	12.60	7.67	23.51	12.30	8.23	22.64	12.00	8.86	20.42	10.97	9.57	19.01	10.42	10.51
		30°C	25.17	15.92	7.19	24.38	15.60	7.68	23.56	15.28	8.24	22.69	14.92	8.87	20.46	13.68	9.57	19.06	13.03	10.51
		33°C	25.24	18.55	7.20	24.45	18.22	7.68	23.63	17.88	8.24	22.76	17.51	8.88	20.53	16.11	9.58	19.13	15.41	10.52
		36°C	25.31	21.12	7.20	24.52	20.79	7.69	23.69	20.44	8.25	22.82	20.08	8.89	20.61	18.49	9.59	19.30	17.63	10.55
2826	16°C	21°C	21.29	15.09	6.86	20.61	14.77	7.33	19.87	14.42	7.88	19.10	14.03	8.50	17.19	12.79	9.19	15.95	12.09	10.11
		24°C	21.40	17.99	6.87	20.72	17.63	7.34	19.99	17.24	7.89	19.21	16.83	8.51	17.29	15.41	9.20	16.04	14.65	10.13
		27°C	21.55	20.86	6.88	20.91	20.41	7.36	20.26	19.88	7.91	19.60	19.26	8.55	17.78	17.56	9.26	16.68	16.52	10.20
		30°C	22.67	22.67	6.98	22.08	22.08	7.46	21.46	21.46	8.03	20.79	20.79	8.67	18.87	18.87	9.39	17.74	17.74	10.34
	19°C	24°C	23.38	14.25	7.04	22.64	13.95	7.51	21.84	13.63	8.07	21.00	13.29	8.69	18.91	12.16	9.39	17.59	11.55	10.32
		27°C	23.46	16.68	7.04	22.72	16.34	7.52	21.93	15.99	8.07	21.10	15.61	8.70	19.01	14.31	9.40	17.68	13.62	10.33
		30°C	23.57	20.46	7.05	22.82	20.10	7.53	22.02	19.72	8.09	21.19	19.32	8.71	19.11	17.76	9.41	17.82	16.89	10.35
		33°C	23.94	23.94	7.08	23.33	23.33	7.58	22.68	22.68	8.15	22.00	22.00	8.80	19.99	19.99	9.52	18.82	18.82	10.48
	22°C	27°C	25.62	13.38	7.23	24.80	13.09	7.72	23.94	12.80	8.28	23.04	12.49	8.91	20.77	11.44	9.61	19.33	10.89	10.55
		30°C	25.68	16.61	7.23	24.86	16.28	7.72	24.01	15.94	8.28	23.11	15.58	8.92	20.84	14.29	9.62	19.41	13.62	10.56
		33°C	25.78	19.43	7.24	24.96	19.09	7.73	24.10	18.74	8.29	23.20	18.37	8.93	20.92	16.91	9.63	19.49	16.19	10.57
		36°C	25.87	22.21	7.25	25.05	21.87	7.74	24.20	21.48	8.30	23.37	21.03	8.94	21.18	19.44	9.66	19.91	18.53	10.63
3109	16°C	21°C	21.67	15.51	6.89	20.96	15.15	7.36	20.21	14.76	7.91	19.42	14.36	8.53	17.46	13.09	9.22	16.20	12.37	10.15
		24°C	21.81	18.48	6.90	21.10	18.11	7.38	20.35	17.71	7.92	19.55	17.30	8.54	17.58	15.85	9.23	16.31	15.08	10.16
		27°C	22.11	21.54	6.93	21.50	21.18	7.41	20.86	20.77	7.97	20.19	20.19	8.61	18.30	18.30	9.32	17.16	17.16	10.27
		30°C	23.40	23.40	7.04	22.78	22.78	7.53	22.12	22.12	8.09	21.42	21.42	8.73	19.44	19.44	9.45	18.26	18.26	10.41
	19°C	24°C	23.77	14.91	7.07	23.00	14.61	7.55	22.18	14.28	8.10	21.32	13.93	8.72	19.20	12.73	9.42	17.84	12.06	10.35
		27°C	23.89	17.45	7.08	23.12	17.11	7.56	22.30	16.74	8.11	21.44	16.36	8.74	19.31	15.00	9.44	17.94	14.29	10.37
		30°C	24.01	21.51	7.09	23.23	21.13	7.57	22.43	20.74	8.12	21.59	20.29	8.75	19.51	18.55	9.46	18.26	17.52	10.41
		33°C	24.72	24.72	7.15	24.08	24.08	7.65	23.40	23.40	8.22	22.68	22.68	8.87	20.61	20.61	9.59	19.39	19.39	10.56
	22°C	27°C	26.03	13.99	7.26	25.18	13.71	7.75	24.30	13.41	8.31	23.38	13.10	8.94	21.07	12.02	9.65	19.60	11.43	10.58
		30°C	26.11	17.40	7.27	25.27	17.06	7.76	24.40	16.70	8.32	23.48	16.33	8.96	21.16	14.99	9.66	19.70	14.30	10.60
		33°C	26.24	20.44	7.28	25.39	20.09	7.77	24.51	19.73	8.33	23.58	19.35	8.97	21.25	17.82	9.67	19.78	17.08	10.61
		36°C	26.37	23.41	7.30	25.58	22.97	7.79	24.77	22.47	8.36	23.97	21.88	9.01	21.79	20.12	9.74	20.53	19.11	10.71

**Remark:**

- AFR: Air flow rate (CFM)
- EWB: Entering Wet Bulb Temp. (°C)
- EDB: Entering Dry Bulb Temp. (°C)
- TC: Total Cooling Capacity (kW)
- SC: Sensible Cooling Capacity (kW)
- PI: Power Input (kW)

**Notes:**

1. Ratings shown are net capacities.
2. ■ shows nominal capacities.
3. Direct interpolation is permissible. Do not extrapolate.
4. Unit is able to operate at ambient from 19°C to 46°C DB without pressure trip.

## Model: UATP100AGXY1

## Cooling Mode

AFR (CFM)	EWB	EDB	Outdoor temperature																	
			19°C			25°C			30°C			35°C			40°C			46°C		
			TC	SC	PI	TC	SC	PI	TC	SC	PI	TC	SC	PI	TC	SC	PI	TC	SC	PI
3179	16°C	21°C	27.51	19.66	9.10	26.64	19.23	9.72	25.71	18.77	10.45	24.72	18.28	11.28	22.24	16.69	12.20	20.66	15.79	13.43
		24°C	27.62	23.42	9.11	26.75	22.93	9.74	25.82	22.42	10.46	24.84	21.87	11.29	22.36	20.02	12.21	20.77	19.02	13.45
		27°C	27.72	26.96	9.12	26.87	26.46	9.75	25.97	25.91	10.48	25.05	25.05	11.31	22.68	22.68	12.25	21.28	21.28	13.51
		30°C	28.82	28.82	9.21	28.09	28.09	9.86	27.31	27.31	10.61	26.47	26.47	11.46	24.05	24.05	12.41	22.61	22.61	13.69
	19°C	24°C	30.23	18.58	9.33	29.29	18.17	9.96	28.28	17.74	10.70	27.21	17.29	11.53	24.51	15.81	12.47	22.79	15.00	13.71
		27°C	30.30	21.70	9.33	29.36	21.26	9.97	28.36	20.79	10.71	27.30	20.29	11.54	24.60	18.58	12.48	22.89	17.68	13.72
		30°C	30.42	26.48	9.34	29.46	26.00	9.98	28.45	25.50	10.72	27.38	24.97	11.56	24.69	22.95	12.49	22.98	21.95	13.73
		33°C	30.60	30.60	9.36	29.72	29.72	10.01	28.86	28.86	10.76	27.99	27.99	11.62	25.45	25.45	12.58	23.97	23.97	13.86
	22°C	27°C	33.16	17.45	9.58	32.12	17.07	10.23	31.02	16.67	10.98	29.88	16.26	11.82	26.95	14.87	12.76	25.09	14.13	14.01
		30°C	33.21	21.57	9.59	32.17	21.15	10.24	31.08	20.70	10.98	29.93	20.22	11.83	27.00	18.54	12.77	25.15	17.66	14.02
		33°C	33.30	25.14	9.59	32.26	24.69	10.25	31.17	24.22	10.99	30.02	23.73	11.84	27.09	21.83	12.78	25.24	20.89	14.03
		36°C	33.40	28.63	9.60	32.36	28.17	10.25	31.25	27.70	11.00	30.11	27.21	11.85	27.20	25.06	12.79	25.46	23.89	14.06
3532	16°C	21°C	28.09	20.46	9.15	27.19	20.02	9.77	26.22	19.54	10.50	25.20	19.01	11.33	22.68	17.34	12.25	21.05	16.39	13.48
		24°C	28.24	24.38	9.16	27.34	23.89	9.79	26.38	23.36	10.51	25.35	22.80	11.34	22.81	20.88	12.27	21.17	19.86	13.50
		27°C	28.43	28.27	9.18	27.59	27.59	9.81	26.73	26.73	10.55	25.86	25.86	11.39	23.46	23.46	12.34	22.00	22.00	13.61
		30°C	29.91	29.91	9.30	29.14	29.14	9.95	28.31	28.31	10.70	27.43	27.43	11.56	24.90	24.90	12.51	23.40	23.40	13.79
	19°C	24°C	30.84	19.31	9.38	29.87	18.90	10.02	28.82	18.47	10.75	27.71	18.01	11.59	24.95	16.48	12.52	23.20	15.65	13.76
		27°C	30.96	22.60	9.39	29.98	22.15	10.03	28.94	21.66	10.77	27.84	21.16	11.60	25.08	19.39	12.53	23.32	18.46	13.77
		30°C	31.10	27.72	9.40	30.11	27.23	10.04	29.06	26.72	10.78	27.96	26.18	11.62	25.21	24.07	12.55	23.51	22.89	13.80
		33°C	31.59	31.59	9.44	30.78	30.78	10.10	29.93	29.93	10.87	29.02	29.02	11.73	26.38	26.38	12.69	24.83	24.83	13.98
	22°C	27°C	33.80	18.13	9.64	32.72	17.74	10.29	31.59	17.34	11.03	30.40	16.92	11.88	27.40	15.50	12.82	25.51	14.75	14.07
		30°C	33.88	22.51	9.65	32.80	22.06	10.30	31.68	21.60	11.04	30.49	21.11	11.89	27.49	19.36	12.83	25.61	18.45	14.08
		33°C	34.01	26.33	9.66	32.94	25.87	10.31	31.80	25.39	11.06	30.61	24.89	11.90	27.60	22.91	12.84	25.71	21.94	14.09
		36°C	34.13	30.10	9.67	33.05	29.64	10.32	31.93	29.11	11.07	30.83	28.49	11.93	27.94	26.34	12.88	26.28	25.11	14.17
3885	16°C	21°C	28.59	21.01	9.19	27.65	20.53	9.82	26.66	20.01	10.54	25.62	19.46	11.37	23.04	17.74	12.29	21.37	16.77	13.53
		24°C	28.77	25.04	9.21	27.84	24.54	9.83	26.85	24.00	10.56	25.79	23.44	11.39	23.19	21.47	12.31	21.52	20.44	13.55
		27°C	29.17	29.17	9.24	28.36	28.36	9.88	27.53	27.53	10.63	26.63	26.63	11.47	24.14	24.14	12.42	22.63	22.63	13.69
		30°C	30.87	30.87	9.38	30.05	30.05	10.04	29.19	29.19	10.79	28.27	28.27	11.65	25.65	25.65	12.60	24.09	24.09	13.88
	19°C	24°C	31.36	20.21	9.43	30.35	19.79	10.06	29.27	19.35	10.80	28.13	18.88	11.63	25.33	17.25	12.56	23.53	16.35	13.80
		27°C	31.52	23.65	9.44	30.51	23.19	10.08	29.43	22.69	10.82	28.29	22.17	11.65	25.47	20.32	12.58	23.67	19.37	13.82
		30°C	31.68	29.15	9.45	30.65	28.64	10.09	29.59	28.10	10.83	28.49	27.50	11.67	25.74	25.14	12.61	24.10	23.74	13.88
		33°C	32.61	32.61	9.53	31.77	31.77	10.20	30.88	30.88	10.96	29.93	29.93	11.83	27.19	27.19	12.79	25.58	25.58	14.08
	22°C	27°C	34.34	18.96	9.69	33.23	18.57	10.34	32.06	18.17	11.08	30.84	17.75	11.93	27.79	16.28	12.86	25.86	15.49	14.11
		30°C	34.45	23.58	9.70	33.35	23.12	10.35	32.19	22.64	11.10	30.97	22.13	11.94	27.92	20.31	12.88	25.99	19.37	14.13
		33°C	34.62	27.69	9.71	33.50	27.22	10.36	32.33	26.73	11.11	31.11	26.22	11.96	28.04	24.14	12.90	26.10	23.14	14.15
		36°C	34.79	31.72	9.73	33.75	31.13	10.39	32.69	30.44	11.15	31.63	29.65	12.02	28.75	27.26	12.99	27.09	25.89	14.28

## Remark:

AFR: Air flow rate (CFM)  
EWB: Entering Wet Bulb Temp. (°C)  
EDB: Entering Dry Bulb Temp. (°C)  
TC: Total Cooling Capacity (kW)  
SC: Sensible Cooling Capacity (kW)  
PI: Power Input (kW)

## Notes:

1. Ratings shown are net capacities.
2. ■ shows nominal capacities.
3. Direct interpolation is permissible. Do not extrapolate.
4. Unit is able to operate at ambient from 19°C to 46°C DB without pressure trip.

**Model: UATP120AGXY1**

**Cooling Mode**

AFR (CFM)	EWB	EDB	Outdoor temperature																	
			19°C			25°C			30°C			35°C			40°C			46°C		
			TC	SC	PI	TC	SC	PI	TC	SC	PI	TC	SC	PI	TC	SC	PI	TC	SC	PI
3240	16°C	21°C	31.86	22.47	9.55	30.85	21.98	10.21	29.78	21.45	10.97	28.63	20.89	11.84	25.76	19.07	12.81	23.93	18.04	14.11
		24°C	31.98	26.77	9.56	30.97	26.21	10.22	29.90	25.62	10.98	28.76	25.00	11.85	25.90	22.88	12.83	24.05	21.74	14.12
		27°C	32.10	30.81	9.58	31.12	30.24	10.23	30.08	29.61	11.00	29.01	28.85	11.88	26.26	26.26	12.86	24.64	24.64	14.19
		30°C	33.37	33.37	9.67	32.53	32.53	10.35	31.63	31.63	11.14	30.66	30.66	12.03	27.85	27.85	13.03	26.19	26.19	14.37
	19°C	24°C	35.00	21.23	9.80	33.92	20.77	10.46	32.75	20.28	11.23	31.51	19.76	12.11	28.39	18.06	13.09	26.39	17.14	14.39
		27°C	35.09	24.80	9.80	34.00	24.29	10.47	32.84	23.76	11.24	31.61	23.19	12.12	28.49	21.24	13.10	26.51	20.20	14.40
		30°C	35.23	30.26	9.81	34.12	29.72	10.48	32.95	29.14	11.26	31.70	28.53	12.13	28.59	26.23	13.11	26.61	25.08	14.42
		33°C	35.43	35.43	9.83	34.42	34.42	10.51	33.42	33.42	11.30	32.42	32.42	12.20	29.48	29.48	13.21	27.76	27.76	14.56
	22°C	27°C	38.41	19.95	10.06	37.19	19.51	10.74	35.93	19.05	11.53	34.60	18.58	12.41	31.20	17.00	13.40	29.05	16.14	14.71
		30°C	38.46	24.65	10.07	37.25	24.17	10.75	35.99	23.66	11.53	34.66	23.11	12.42	31.27	21.19	13.40	29.13	20.18	14.72
		33°C	38.57	28.73	10.07	37.36	28.22	10.76	36.10	27.68	11.54	34.77	27.12	12.43	31.37	24.95	13.42	29.23	23.87	14.73
		36°C	38.68	32.71	10.08	37.47	32.20	10.77	36.19	31.65	11.55	34.87	31.09	12.44	31.49	28.64	13.43	29.49	27.30	14.76
3600	16°C	21°C	32.53	23.38	9.61	31.49	22.88	10.26	30.36	22.33	11.03	29.18	21.72	11.89	26.26	19.81	12.86	24.37	18.73	14.16
		24°C	32.70	27.87	9.62	31.66	27.30	10.28	30.55	26.70	11.04	29.36	26.06	11.91	26.42	23.86	12.88	24.51	22.69	14.18
		27°C	32.93	32.31	9.64	31.95	31.61	10.30	30.95	30.79	11.08	29.95	29.83	11.96	27.16	27.16	12.96	25.48	25.48	14.29
		30°C	34.63	34.63	9.77	33.74	33.74	10.45	32.78	32.78	11.24	31.76	31.76	12.14	28.84	28.84	13.14	27.10	27.10	14.48
	19°C	24°C	35.72	22.07	9.85	34.59	21.60	10.52	33.37	21.11	11.29	32.09	20.59	12.17	28.90	18.83	13.14	26.87	17.89	14.45
		27°C	35.85	25.83	9.86	34.72	25.31	10.53	33.51	24.76	11.30	32.24	24.18	12.18	29.04	22.16	13.16	27.01	21.10	14.46
		30°C	36.02	31.68	9.87	34.86	31.12	10.54	33.65	30.53	11.32	32.38	29.92	12.20	29.19	27.50	13.18	27.22	26.16	14.49
		33°C	36.58	36.58	9.92	35.64	35.64	10.61	34.66	34.66	11.41	33.61	33.61	12.31	30.55	30.55	13.33	28.75	28.75	14.68
	22°C	27°C	39.15	20.72	10.12	37.89	20.28	10.80	36.58	19.82	11.59	35.20	19.34	12.47	31.73	17.72	13.46	29.54	16.86	14.77
		30°C	39.24	25.73	10.13	37.99	25.21	10.81	36.69	24.68	11.60	35.31	24.12	12.48	31.84	22.12	13.47	29.65	21.09	14.78
		33°C	39.39	30.09	10.14	38.14	29.56	10.83	36.83	29.02	11.61	35.45	28.44	12.50	31.97	26.18	13.48	29.77	25.07	14.80
		36°C	39.53	34.40	10.15	38.27	33.87	10.84	36.98	33.26	11.63	35.70	32.56	12.52	32.36	30.10	13.53	30.43	28.70	14.88
3960	16°C	21°C	33.11	24.01	9.65	32.02	23.46	10.31	30.88	22.86	11.07	29.67	22.24	11.94	26.68	20.27	12.91	24.75	19.16	14.20
		24°C	33.32	28.62	9.67	32.24	28.04	10.33	31.09	27.43	11.09	29.87	26.79	11.96	26.86	24.54	12.93	24.92	23.36	14.22
		27°C	33.79	33.35	9.70	32.85	32.80	10.37	31.88	31.88	11.16	30.84	30.84	12.05	27.96	27.96	13.04	26.21	26.21	14.37
		30°C	35.75	35.75	9.85	34.80	34.80	10.54	33.80	33.80	11.33	32.73	32.73	12.23	29.71	29.71	13.23	27.90	27.90	14.57
	19°C	24°C	36.31	23.09	9.90	35.14	22.62	10.57	33.90	22.12	11.34	32.58	21.58	12.21	29.33	19.72	13.19	27.25	18.68	14.49
		27°C	36.50	27.03	9.91	35.33	26.50	10.58	34.08	25.93	11.36	32.77	25.33	12.23	29.50	23.23	13.21	27.41	22.13	14.51
		30°C	36.69	33.31	9.93	35.49	32.73	10.60	34.27	32.11	11.37	32.99	31.42	12.25	29.81	28.73	13.24	27.91	27.13	14.57
		33°C	37.76	37.76	10.01	36.79	36.79	10.71	35.76	35.76	11.51	34.66	34.66	12.42	31.49	31.49	13.43	29.62	29.62	14.78
	22°C	27°C	39.77	21.67	10.17	38.48	21.23	10.85	37.13	20.76	11.64	35.72	20.29	12.52	32.19	18.61	13.51	29.95	17.71	14.82
		30°C	39.90	26.95	10.18	38.62	26.42	10.87	37.28	25.87	11.65	35.87	25.29	12.54	32.33	23.21	13.52	30.09	22.14	14.84
		33°C	40.09	31.65	10.20	38.80	31.11	10.88	37.45	30.55	11.67	36.03	29.96	12.56	32.47	27.59	13.54	30.23	26.44	14.86
		36°C	40.29	36.25	10.21	39.08	35.58	10.91	37.85	34.79	11.71	36.63	33.89	12.62	33.30	31.16	13.64	31.37	29.59	15.00

**Remark:**

- AFR: Air flow rate (CFM)
- EWB: Entering Wet Bulb Temp. (°C)
- EDB: Entering Dry Bulb Temp. (°C)
- TC: Total Cooling Capacity (kW)
- SC: Sensible Cooling Capacity (kW)
- PI: Power Input (kW)

**Notes:**

1. Ratings shown are net capacities.
2. ■ shows nominal capacities.
3. Direct interpolation is permissible. Do not extrapolate.
4. Unit is able to operate at ambient from 19°C to 46°C DB without pressure trip.

**Model: UATP150AGXY1**

**Cooling Mode**

AFR (CFM)	EWB	EDB	Outdoor temperature																	
			19°C			25°C			30°C			35°C			40°C			46°C		
			TC	SC	PI	TC	SC	PI	TC	SC	PI	TC	SC	PI	TC	SC	PI	TC	SC	PI
5086	16°C	21°C	40.55	27.84	13.49	39.26	27.22	14.42	37.90	26.57	15.50	36.43	25.88	16.72	32.78	23.63	18.09	30.45	22.35	19.92
		24°C	40.70	33.16	13.51	39.42	32.47	14.43	38.06	31.74	15.51	36.60	30.96	16.74	32.96	28.34	18.11	30.61	26.93	19.94
		27°C	40.85	38.16	13.52	39.61	37.45	14.45	38.28	36.68	15.53	36.92	35.74	16.77	33.42	32.54	18.17	31.36	30.56	20.04
		30°C	42.47	42.47	13.65	41.40	41.40	14.61	40.25	40.25	15.73	39.02	39.02	16.99	35.44	35.44	18.40	33.33	33.33	20.29
	19°C	24°C	44.55	26.30	13.83	43.16	25.73	14.77	41.68	25.12	15.86	40.11	24.48	17.10	36.13	22.38	18.48	33.59	21.23	20.33
		27°C	44.66	30.72	13.84	43.27	30.09	14.79	41.79	29.43	15.88	40.23	28.72	17.11	36.26	26.31	18.50	33.73	25.03	20.34
		30°C	44.83	37.49	13.86	43.42	36.81	14.80	41.93	36.10	15.90	40.35	35.34	17.13	36.38	32.49	18.52	33.87	31.07	20.36
		33°C	45.09	45.09	13.88	43.81	43.81	14.84	42.53	42.53	15.95	41.25	41.25	17.23	37.51	37.51	18.65	35.33	35.33	20.56
	22°C	27°C	48.88	24.71	14.21	47.33	24.16	15.17	45.72	23.60	16.28	44.03	23.01	17.53	39.71	21.05	18.92	36.97	20.00	20.78
		30°C	48.94	30.54	14.21	47.40	29.93	15.18	45.81	29.30	16.28	44.12	28.63	17.53	39.79	26.24	18.93	37.07	25.00	20.79
		33°C	49.08	35.59	14.23	47.55	34.95	15.19	45.94	34.29	16.30	44.25	33.60	17.55	39.92	30.90	18.95	37.20	29.56	20.81
		36°C	49.22	40.52	14.24	47.69	39.88	15.21	46.06	39.21	16.32	44.38	38.51	17.57	40.08	35.48	18.97	37.53	33.81	20.85
5651	16°C	21°C	41.40	28.96	13.56	40.07	28.34	14.49	38.64	27.66	15.57	37.13	26.91	16.80	33.42	24.54	18.16	31.02	23.20	19.99
		24°C	41.61	34.52	13.58	40.29	33.82	14.51	38.87	33.07	15.59	37.36	32.28	16.82	33.62	29.56	18.19	31.20	28.11	20.02
		27°C	41.90	40.02	13.61	40.66	39.16	14.55	39.39	38.14	15.64	38.12	36.95	16.90	34.57	33.68	18.30	32.43	31.69	20.17
		30°C	44.08	44.08	13.79	42.94	42.94	14.75	41.72	41.72	15.87	40.42	40.42	17.14	36.70	36.70	18.55	34.49	34.49	20.44
	19°C	24°C	45.45	27.33	13.91	44.02	26.76	14.85	42.47	26.14	15.95	40.84	25.50	17.18	36.78	23.33	18.56	34.19	22.16	20.40
		27°C	45.63	31.99	13.92	44.19	31.35	14.87	42.65	30.67	15.96	41.03	29.95	17.20	36.96	27.45	18.58	34.37	26.14	20.42
		30°C	45.83	39.24	13.94	44.37	38.55	14.89	42.82	37.82	15.98	41.21	37.07	17.22	37.15	34.07	18.61	34.65	32.40	20.47
		33°C	46.55	46.55	14.00	45.36	45.36	14.98	44.11	44.11	16.11	42.77	42.77	17.39	38.88	38.88	18.82	36.59	36.59	20.72
	22°C	27°C	49.82	25.66	14.29	48.22	25.12	15.26	46.56	24.55	16.36	44.80	23.96	17.61	40.39	21.94	19.00	37.59	20.88	20.86
		30°C	49.94	31.87	14.30	48.35	31.23	15.27	46.69	30.57	16.37	44.94	29.88	17.63	40.52	27.40	19.02	37.74	26.12	20.87
		33°C	50.13	37.27	14.32	48.54	36.62	15.29	46.87	35.94	16.40	45.11	35.23	17.65	40.68	32.43	19.04	37.89	31.06	20.90
		36°C	50.30	42.61	14.34	48.71	41.95	15.31	47.06	41.20	16.42	45.43	40.33	17.68	41.18	37.28	19.10	38.72	35.55	21.01
6216	16°C	21°C	42.13	29.74	13.63	40.75	29.06	14.56	39.29	28.32	15.63	37.76	27.54	16.86	33.96	25.11	18.23	31.50	23.74	20.06
		24°C	42.40	35.45	13.65	41.02	34.73	14.58	39.57	33.98	15.66	38.01	33.18	16.89	34.18	30.40	18.26	31.72	28.94	20.08
		27°C	43.00	41.31	13.70	41.80	40.64	14.65	40.57	39.84	15.76	39.25	38.94	17.01	35.58	35.40	18.42	33.36	33.36	20.30
		30°C	45.49	45.49	13.91	44.29	44.29	14.88	43.02	43.02	16.00	41.66	41.66	17.27	37.81	37.81	18.69	35.51	35.51	20.58
	19°C	24°C	46.21	28.60	13.98	44.72	28.02	14.92	43.14	27.40	16.01	41.46	26.73	17.25	37.33	24.42	18.63	34.68	23.14	20.47
		27°C	46.45	33.48	14.00	44.96	32.82	14.94	43.37	32.12	16.04	41.70	31.38	17.27	37.54	28.77	18.66	34.89	27.41	20.50
		30°C	46.69	41.26	14.02	45.17	40.54	14.97	43.61	39.78	16.06	41.99	38.92	17.30	37.94	35.59	18.70	35.52	33.60	20.58
		33°C	48.06	48.06	14.14	46.82	46.82	15.12	45.51	45.51	16.25	44.11	44.11	17.54	40.07	40.07	18.97	37.70	37.70	20.87
	22°C	27°C	50.61	26.84	14.36	48.97	26.29	15.33	47.25	25.72	16.43	45.45	25.13	17.68	40.96	23.05	19.07	38.11	21.93	20.92
		30°C	50.78	33.38	14.38	49.15	32.73	15.35	47.44	32.04	16.45	45.65	31.33	17.70	41.15	28.75	19.10	38.30	27.42	20.95
		33°C	51.02	39.20	14.40	49.37	38.54	15.37	47.65	37.84	16.48	45.85	37.11	17.73	41.32	34.18	19.12	38.47	32.76	20.98
		36°C	51.28	44.90	14.42	49.74	44.07	15.40	48.17	43.10	16.53	46.61	41.97	17.82	42.38	38.60	19.26	39.92	36.65	21.18

**Remark:**

- AFR: Air flow rate (CFM)
- EWB: Entering Wet Bulb Temp. (°C)
- EDB: Entering Dry Bulb Temp. (°C)
- TC: Total Cooling Capacity (kW)
- SC: Sensible Cooling Capacity (kW)
- PI: Power Input (kW)

**Notes:**

1. Ratings shown are net capacities.
2. ■ shows nominal capacities.
3. Direct interpolation is permissible. Do not extrapolate.
4. Unit is able to operate at ambient from 19°C to 46°C DB without pressure trip.

**Model: UATP200AGXY1**

**Cooling Mode**

AFR (CFM)	EWB	EDB	Outdoor temperature																	
			19°C			25°C			30°C			35°C			40°C			46°C		
			TC	SC	PI	TC	SC	PI	TC	SC	PI	TC	SC	PI	TC	SC	PI	TC	SC	PI
6039	16°C	21°C	55.03	36.75	19.69	53.29	35.94	21.04	51.44	35.08	22.61	49.45	34.17	24.40	44.50	31.19	26.40	41.33	29.51	29.07
		24°C	55.25	43.77	19.71	53.50	42.86	21.06	51.65	41.90	22.64	49.68	40.88	24.43	44.73	37.41	26.43	41.54	35.55	29.10
		27°C	55.45	50.38	19.73	53.76	49.44	21.09	51.95	48.42	22.67	50.11	47.17	24.48	45.36	42.96	26.51	42.57	40.35	29.24
		30°C	57.65	57.65	19.93	56.20	56.20	21.33	54.63	54.63	22.95	52.96	52.96	24.79	48.11	48.11	26.86	45.24	45.24	29.61
	19°C	24°C	60.46	34.71	20.19	58.59	33.96	21.56	56.57	33.16	23.15	54.44	32.31	24.96	49.04	29.54	26.97	45.59	28.03	29.66
		27°C	60.62	40.55	20.20	58.73	39.73	21.58	56.73	38.85	23.17	54.60	37.92	24.98	49.21	34.73	26.99	45.79	33.04	29.68
		30°C	60.85	49.49	20.22	58.93	48.59	21.60	56.91	47.65	23.20	54.77	46.66	25.00	49.38	42.89	27.02	45.97	41.01	29.71
		33°C	61.21	61.21	20.25	59.46	59.46	21.65	57.73	57.73	23.28	55.99	55.99	25.14	50.92	50.92	27.22	47.95	47.95	30.00
	22°C	27°C	66.34	32.61	20.73	64.24	31.90	22.14	62.06	31.15	23.75	59.76	30.38	25.58	53.90	27.79	27.61	50.18	26.40	30.32
		30°C	66.43	40.32	20.74	64.34	39.52	22.15	62.17	38.68	23.76	59.88	37.79	25.59	54.01	34.64	27.62	50.32	33.00	30.33
		33°C	66.62	46.98	20.76	64.54	46.14	22.17	62.36	45.27	23.79	60.06	44.35	25.61	54.19	40.79	27.65	50.49	39.03	30.36
		36°C	66.81	53.49	20.78	64.73	52.65	22.19	62.52	51.76	23.81	60.24	50.84	25.64	54.40	46.84	27.68	50.93	44.64	30.43
6710	16°C	21°C	56.19	38.23	19.79	54.39	37.41	21.15	52.45	36.52	22.72	50.40	35.52	24.51	45.36	32.40	26.51	42.10	30.62	29.17
		24°C	56.48	45.57	19.82	54.68	44.64	21.18	52.76	43.66	22.75	50.71	42.61	24.54	45.64	39.02	26.54	42.34	37.11	29.21
		27°C	56.88	52.83	19.86	55.19	51.69	21.23	53.46	50.35	22.83	51.74	48.78	24.66	46.92	44.46	26.71	44.01	41.83	29.44
		30°C	59.82	59.82	20.13	58.28	58.28	21.53	56.63	56.63	23.16	54.87	54.87	25.01	49.82	49.82	27.08	46.81	46.81	29.83
	19°C	24°C	61.70	36.08	20.30	59.74	35.32	21.68	57.65	34.51	23.27	55.43	33.66	25.07	49.92	30.80	27.09	46.41	29.25	29.77
		27°C	61.93	42.24	20.32	59.97	41.39	21.70	57.89	40.49	23.29	55.69	39.54	25.10	50.16	36.23	27.12	46.65	34.50	29.80
		30°C	62.21	51.81	20.35	60.22	50.89	21.73	58.12	49.93	23.33	55.93	48.93	25.13	50.42	44.97	27.15	47.03	42.78	29.87
		33°C	63.18	63.18	20.43	61.57	61.57	21.86	59.87	59.87	23.51	58.05	58.05	25.38	52.77	52.77	27.46	49.67	49.67	30.24
	22°C	27°C	67.62	33.87	20.86	65.45	33.16	22.26	63.19	32.41	23.88	60.81	31.63	25.70	54.82	28.97	27.73	51.02	27.56	30.43
		30°C	67.78	42.07	20.87	65.62	41.23	22.28	63.37	40.36	23.90	60.99	39.44	25.72	55.00	36.18	27.75	51.22	34.49	30.46
		33°C	68.04	49.20	20.90	65.89	48.35	22.31	63.61	47.45	23.93	61.23	46.51	25.75	55.22	42.81	27.79	51.43	41.00	30.50
		36°C	68.28	56.25	20.92	66.11	55.38	22.33	63.88	54.39	23.96	61.67	53.24	25.80	55.90	49.22	27.88	52.56	46.93	30.67
7381	16°C	21°C	57.19	39.27	19.88	55.31	38.36	21.24	53.33	37.39	22.81	51.25	36.36	24.60	46.09	33.15	26.60	42.75	31.34	29.27
		24°C	57.56	46.79	19.92	55.68	45.85	21.28	53.70	44.86	22.85	51.59	43.81	24.64	46.39	40.13	26.64	43.05	38.20	29.31
		27°C	58.36	54.54	19.99	56.74	53.64	21.38	55.07	52.60	22.99	53.28	51.40	24.83	48.29	46.73	26.88	45.28	44.03	29.62
		30°C	61.75	61.75	20.30	60.11	60.11	21.72	58.39	58.39	23.35	56.54	56.54	25.20	51.31	51.31	27.27	48.19	48.19	30.03
	19°C	24°C	62.73	37.76	20.39	60.70	36.99	21.77	58.55	36.17	23.37	56.27	35.28	25.17	50.67	32.24	27.18	47.07	30.55	29.87
		27°C	63.04	44.20	20.42	61.03	43.33	21.81	58.86	42.40	23.40	56.60	41.42	25.21	50.96	37.98	27.22	47.35	36.19	29.91
		30°C	63.37	54.47	20.46	61.30	53.52	21.84	59.20	52.51	23.44	56.99	51.38	25.25	51.49	46.98	27.29	48.21	44.36	30.03
		33°C	65.23	65.23	20.63	63.54	63.54	22.07	61.76	61.76	23.72	59.87	59.87	25.59	54.39	54.39	27.68	51.17	51.17	30.46
	22°C	27°C	68.69	35.43	20.96	66.47	34.71	22.37	64.13	33.95	23.98	61.70	33.18	25.80	55.60	30.43	27.83	51.73	28.95	30.54
		30°C	68.92	44.07	20.98	66.71	43.20	22.39	64.39	42.30	24.01	61.96	41.35	25.84	55.85	37.95	27.87	51.98	36.20	30.57
		33°C	69.25	51.75	21.02	67.02	50.87	22.43	64.68	49.95	24.05	62.23	48.99	25.87	56.09	45.12	27.91	52.21	43.24	30.61
		36°C	69.60	59.27	21.05	67.51	58.18	22.48	65.39	56.89	24.13	63.27	55.41	26.00	57.52	50.95	28.10	54.19	48.38	30.91

**Remark:**

AFR: Air flow rate (CFM)  
 EWB: Entering Wet Bulb Temp. (°C)  
 EDB: Entering Dry Bulb Temp. (°C)  
 TC: Total Cooling Capacity (kW)  
 SC: Sensible Cooling Capacity (kW)  
 PI: Power Input (kW)

**Notes:**

1. Ratings shown are net capacities.
2. ■ shows nominal capacities.
3. Direct interpolation is permissible. Do not extrapolate.
4. Unit is able to operate at ambient from 19°C to 46°C DB without pressure trip.

**Model: UATP250AGXY1**

**Cooling Mode**

AFR (CFM)	EWB	EDB	Outdoor temperature																	
			19°C			25°C			30°C			35°C			40°C			46°C		
			TC	SC	PI	TC	SC	PI	TC	SC	PI	TC	SC	PI	TC	SC	PI	TC	SC	PI
7200	16°C	21°C	66.61	50.12	22.51	64.50	49.01	24.06	62.26	47.84	25.86	59.85	46.60	27.90	53.86	42.54	30.19	50.03	40.24	33.24
		24°C	66.87	59.70	22.54	64.76	58.46	24.09	62.52	57.14	25.88	60.13	55.75	27.93	54.15	51.03	30.22	50.29	48.49	33.27
		27°C	67.12	67.12	22.56	65.07	65.07	24.11	62.89	62.89	25.92	60.65	60.65	27.99	54.90	54.90	30.31	51.53	51.53	33.44
		30°C	69.78	69.78	22.78	68.02	68.02	24.38	66.13	66.13	26.24	64.10	64.10	28.35	58.23	58.23	30.71	54.76	54.76	33.86
	19°C	24°C	73.19	47.35	23.08	70.91	46.32	24.65	68.48	45.22	26.47	65.89	44.07	28.53	59.36	40.29	30.84	55.19	38.23	33.91
		27°C	73.38	55.31	23.09	71.09	54.18	24.67	68.67	52.98	26.49	66.09	51.72	28.56	59.57	47.37	30.87	55.42	45.06	33.94
		30°C	73.66	67.50	23.12	71.34	66.27	24.70	68.89	64.99	26.52	66.29	63.64	28.59	59.77	58.50	30.90	55.65	55.65	33.98
		33°C	74.09	74.09	23.15	71.97	71.97	24.75	69.87	69.87	26.62	67.78	67.78	28.74	61.63	61.63	31.13	58.05	58.05	34.30
	22°C	27°C	80.30	44.48	23.71	77.76	43.50	25.31	75.12	42.49	27.16	72.34	41.43	29.24	65.25	37.91	31.57	60.74	36.01	34.67
		30°C	80.41	54.99	23.72	77.88	53.90	25.32	75.26	52.76	27.17	72.48	51.54	29.26	65.38	47.25	31.58	60.91	45.01	34.68
		33°C	80.64	64.07	23.74	78.12	62.93	25.35	75.48	61.74	27.20	72.70	60.49	29.29	65.59	55.64	31.62	61.12	53.23	34.72
		36°C	80.87	72.96	23.76	78.35	71.81	25.37	75.68	70.59	27.22	72.91	69.34	29.31	65.85	63.88	31.65	61.65	60.88	34.79
8000	16°C	21°C	68.02	52.14	22.63	65.84	51.02	24.18	63.49	49.81	25.98	61.01	48.45	28.02	54.91	44.19	30.31	50.96	41.76	33.36
		24°C	68.37	62.15	22.67	66.19	60.89	24.22	63.87	59.54	26.02	61.38	58.12	28.06	55.24	53.22	30.35	51.25	50.61	33.40
		27°C	68.84	68.84	22.70	66.80	66.80	24.27	64.71	64.71	26.10	62.62	62.62	28.19	56.79	56.79	30.54	53.28	53.28	33.66
		30°C	72.41	72.41	23.01	70.55	70.55	24.62	68.55	68.55	26.48	66.42	66.42	28.60	60.30	60.30	30.96	56.66	56.66	34.11
	19°C	24°C	74.68	49.21	23.21	72.32	48.18	24.78	69.78	47.07	26.61	67.10	45.91	28.67	60.42	42.01	30.97	56.18	39.90	34.04
		27°C	74.96	57.61	23.23	72.59	56.45	24.81	70.07	55.22	26.64	67.41	53.93	28.70	60.72	49.42	31.01	56.47	47.06	34.08
		30°C	75.30	70.66	23.27	72.90	69.41	24.85	70.35	68.10	26.67	67.71	66.74	28.74	61.04	61.04	31.05	56.92	56.92	34.15
		33°C	76.48	76.48	23.37	74.53	74.53	25.00	72.46	72.46	26.88	70.27	70.27	29.02	63.87	63.87	31.40	60.12	60.12	34.58
	22°C	27°C	81.85	46.20	23.85	79.23	45.22	25.46	76.49	44.20	27.30	73.60	43.14	29.39	66.35	39.51	31.71	61.76	37.60	34.80
		30°C	82.04	57.38	23.87	79.43	56.23	25.48	76.71	55.05	27.32	73.83	53.80	29.41	66.57	49.34	31.73	62.00	47.04	34.83
		33°C	82.36	67.10	23.90	79.75	65.94	25.51	77.00	64.72	27.36	74.11	63.44	29.45	66.84	58.39	31.77	62.25	55.92	34.87
		36°C	82.65	76.72	23.92	80.02	75.54	25.54	77.32	74.19	27.39	74.65	72.62	29.51	67.66	67.13	31.88	63.62	63.62	35.07
8800	16°C	21°C	69.22	53.56	22.74	66.96	52.31	24.29	64.56	50.99	26.09	62.03	49.59	28.13	55.79	45.22	30.41	51.75	42.74	33.47
		24°C	69.67	63.82	22.78	67.40	62.54	24.33	65.00	61.18	26.13	62.45	59.75	28.18	56.16	54.73	30.46	52.11	52.10	33.51
		27°C	70.64	70.64	22.85	68.68	68.68	24.45	66.66	66.66	26.29	64.49	64.49	28.39	58.46	58.46	30.74	54.81	54.81	33.86
		30°C	74.74	74.74	23.21	72.77	72.77	24.83	70.67	70.67	26.70	68.44	68.44	28.82	62.11	62.11	31.18	58.34	58.34	34.34
	19°C	24°C	75.93	51.50	23.32	73.48	50.45	24.90	70.87	49.33	26.72	68.12	48.12	28.78	61.33	43.97	31.08	56.98	41.67	34.15
		27°C	76.31	60.29	23.35	73.87	59.09	24.93	71.25	57.82	26.76	68.51	56.50	28.82	61.68	51.80	31.13	57.32	49.36	34.20
		30°C	76.71	74.29	23.39	74.21	72.99	24.97	71.66	71.62	26.80	68.98	68.98	28.87	62.33	62.33	31.21	58.35	58.35	34.34
		33°C	78.96	78.96	23.59	76.92	76.92	25.23	74.76	74.76	27.12	72.47	72.47	29.26	65.84	65.84	31.65	61.94	61.94	34.83
	22°C	27°C	83.15	48.33	23.97	80.46	47.34	25.58	77.63	46.31	27.42	74.68	45.25	29.50	67.30	41.50	31.83	62.61	39.49	34.92
		30°C	83.43	60.11	23.99	80.75	58.92	25.61	77.95	57.69	27.45	75.00	56.40	29.54	67.60	51.76	31.86	62.92	49.38	34.96
		33°C	83.82	70.59	24.03	81.12	69.38	25.64	78.29	68.13	27.50	75.33	66.82	29.59	67.89	61.53	31.91	63.20	58.98	35.01
		36°C	84.24	80.84	24.07	81.72	79.34	25.70	79.15	77.60	27.59	76.59	75.58	29.73	69.62	69.49	32.13	65.59	65.59	35.34

**Remark:**

- AFR: Air flow rate (CFM)
- EWB: Entering Wet Bulb Temp. (°C)
- EDB: Entering Dry Bulb Temp. (°C)
- TC: Total Cooling Capacity (kW)
- SC: Sensible Cooling Capacity (kW)
- PI: Power Input (kW)

**Notes:**

1. Ratings shown are net capacities.
2. ■ shows nominal capacities.
3. Direct interpolation is permissible. Do not extrapolate.
4. Unit is able to operate at ambient from 19°C to 46°C DB without pressure trip.

**Model: UATP300AGXY1**

**Cooling Mode**

AFR (CFM)	EWB	EDB	Outdoor temperature																	
			19°C			25°C			30°C			35°C			40°C			46°C		
			TC	SC	PI	TC	SC	PI	TC	SC	PI	TC	SC	PI	TC	SC	PI	TC	SC	PI
8640	16°C	21°C	81.96	60.12	31.50	79.37	58.80	33.67	76.60	57.39	36.18	73.64	55.90	39.04	66.27	51.03	42.24	61.56	48.28	46.51
		24°C	82.28	71.62	31.53	79.68	70.12	33.70	76.93	68.55	36.22	73.99	66.88	39.08	66.62	61.21	42.29	61.87	58.17	46.56
		27°C	82.58	82.43	31.57	80.06	80.06	33.74	77.38	77.38	36.27	74.63	74.63	39.16	67.55	67.55	42.42	63.40	63.40	46.79
		30°C	85.86	85.86	31.88	83.70	83.70	34.12	81.36	81.36	36.72	78.87	78.87	39.67	71.65	71.65	42.97	67.37	67.37	47.38
	19°C	24°C	90.05	56.80	32.30	87.25	55.56	34.50	84.25	54.25	37.04	81.07	52.87	39.93	73.03	48.33	43.15	67.90	45.86	47.46
		27°C	90.28	66.35	32.32	87.47	65.00	34.52	84.49	63.56	37.07	81.32	62.04	39.96	73.29	56.82	43.19	68.19	54.05	47.50
		30°C	90.63	80.97	32.35	87.77	79.50	34.56	84.76	77.96	37.11	81.56	76.34	40.01	73.55	70.18	43.24	68.47	67.10	47.54
		33°C	91.16	91.16	32.40	88.55	88.55	34.64	85.97	85.97	37.25	83.39	83.39	40.22	75.83	75.83	43.55	71.42	71.42	48.00
	22°C	27°C	98.80	53.36	33.17	95.68	52.19	35.42	92.43	50.97	38.00	89.01	49.70	40.92	80.28	45.47	44.17	74.74	43.19	48.51
		30°C	98.94	65.96	33.19	95.83	64.66	35.44	92.60	63.29	38.02	89.18	61.83	40.94	80.44	56.68	44.20	74.94	54.00	48.53
		33°C	99.22	76.87	33.22	96.12	75.49	35.47	92.87	74.06	38.06	89.45	72.57	40.98	80.70	66.74	44.24	75.20	63.86	48.58
		36°C	99.50	87.53	33.25	96.40	86.14	35.50	93.11	84.68	38.09	89.71	83.18	41.02	81.02	76.63	44.28	75.86	73.03	48.68
9600	16°C	21°C	83.69	62.54	31.67	81.01	61.21	33.84	78.12	59.75	36.35	75.06	58.12	39.21	67.56	53.01	42.41	62.70	50.10	46.68
		24°C	84.12	74.56	31.72	81.44	73.04	33.89	78.58	71.43	36.40	75.52	69.72	39.27	67.97	63.85	42.47	63.06	60.71	46.74
		27°C	84.71	84.71	31.77	82.19	82.19	33.96	79.62	79.62	36.52	77.05	77.05	39.45	69.88	69.88	42.73	65.55	65.55	47.11
		30°C	89.10	89.10	32.20	86.80	86.80	34.45	84.34	84.34	37.06	81.72	81.72	40.01	74.19	74.19	43.32	69.72	69.72	47.74
	19°C	24°C	91.88	59.04	32.48	88.98	57.79	34.68	85.85	56.47	37.23	82.55	55.08	40.11	74.34	50.39	43.34	69.12	47.86	47.63
		27°C	92.23	69.10	32.51	89.32	67.71	34.72	86.22	66.24	37.27	82.94	64.69	40.16	74.71	59.28	43.39	69.48	56.45	47.69
		30°C	92.65	84.76	32.56	89.69	83.27	34.77	86.56	81.69	37.32	83.30	80.06	40.21	75.10	73.58	43.45	70.04	69.99	47.79
		33°C	94.10	94.10	32.70	91.70	91.70	34.98	89.16	89.16	37.62	86.46	86.46	40.60	78.59	78.59	43.94	73.97	73.97	48.39
	22°C	27°C	100.70	55.42	33.37	97.48	54.25	35.62	94.12	53.03	38.20	90.56	51.75	41.12	81.64	47.40	44.37	75.99	45.10	48.70
		30°C	100.95	68.83	33.39	97.73	67.46	35.65	94.38	66.04	38.23	90.83	64.54	41.15	81.91	59.19	44.41	76.29	56.42	48.74
		33°C	101.33	80.50	33.44	98.12	79.10	35.69	94.74	77.63	38.28	91.19	76.10	41.21	82.24	70.05	44.46	76.59	67.08	48.80
		36°C	101.69	92.04	33.48	98.46	90.62	35.74	95.14	89.00	38.33	91.84	87.11	41.29	83.25	80.53	44.61	78.28	76.78	49.07
10560	16°C	21°C	85.17	64.25	31.81	82.38	62.76	33.99	79.43	61.17	36.50	76.32	59.49	39.36	68.64	54.24	42.56	63.67	51.27	46.83
		24°C	85.72	76.56	31.87	82.93	75.02	34.04	79.98	73.40	36.56	76.84	71.67	39.43	69.09	65.66	42.63	64.11	62.50	46.89
		27°C	86.92	86.92	31.98	84.50	84.50	34.21	82.01	82.01	36.79	79.35	79.35	39.72	71.92	71.92	43.01	67.43	67.43	47.39
		30°C	91.96	91.96	32.48	89.53	89.53	34.75	86.96	86.96	37.36	84.21	84.21	40.32	76.42	76.42	43.63	71.78	71.78	48.05
	19°C	24°C	93.42	61.78	32.63	90.41	60.52	34.84	87.20	59.17	37.39	83.81	57.73	40.27	75.46	52.75	43.49	70.11	49.98	47.79
		27°C	93.89	72.32	32.68	90.89	70.89	34.89	87.67	69.37	37.44	84.29	67.78	40.33	75.89	62.14	43.56	70.53	59.21	47.86
		30°C	94.38	89.12	32.73	91.30	87.56	34.95	88.16	85.92	37.50	84.87	84.07	40.40	76.69	76.69	43.67	71.79	71.79	48.06
		33°C	97.15	97.15	33.01	94.64	94.64	35.30	91.99	91.99	37.95	89.16	89.16	40.94	81.01	81.01	44.29	76.20	76.20	48.74
	22°C	27°C	102.31	57.98	33.53	98.99	56.79	35.79	95.51	55.55	38.37	91.88	54.29	41.29	82.81	49.78	44.53	77.04	47.37	48.86
		30°C	102.65	72.10	33.57	99.35	70.69	35.83	95.90	69.21	38.42	92.28	67.66	41.34	83.17	62.09	44.59	77.42	59.23	48.92
		33°C	103.14	84.68	33.62	99.81	83.23	35.88	96.33	81.73	38.47	92.68	80.16	41.40	83.53	73.82	44.65	77.76	70.75	48.98
		36°C	103.65	96.98	33.68	100.54	95.18	35.96	97.38	93.09	38.60	94.23	90.66	41.60	85.66	83.36	44.96	80.70	79.16	49.45

**Remark:**

- AFR: Air flow rate (CFM)
- EWB: Entering Wet Bulb Temp. (°C)
- EDB: Entering Dry Bulb Temp. (°C)
- TC: Total Cooling Capacity (kW)
- SC: Sensible Cooling Capacity (kW)
- PI: Power Input (kW)

**Notes:**

1. Ratings shown are net capacities.
2. ■ shows nominal capacities.
3. Direct interpolation is permissible. Do not extrapolate.
4. Unit is able to operate at ambient from 19°C to 46°C DB without pressure trip.

**Model: UATP360AGXY1**

**Cooling Mode**

AFR (CFM)	EWB	EDB	Outdoor temperature																	
			19°C			25°C			30°C			35°C			40°C			46°C		
			TC	SC	PI	TC	SC	PI	TC	SC	PI	TC	SC	PI	TC	SC	PI	TC	SC	PI
9900	16°C	21°C	95.86	73.93	32.84	92.83	72.30	35.10	89.60	70.57	37.72	86.13	68.74	40.70	77.51	62.75	44.04	72.00	59.36	48.49
		24°C	96.24	88.06	32.88	93.20	86.23	35.14	89.98	84.29	37.76	86.54	82.24	40.75	77.92	75.27	44.09	72.37	71.52	48.54
		27°C	96.59	96.59	32.92	93.65	93.65	35.18	90.50	90.50	37.81	87.29	87.29	40.83	79.01	79.01	44.22	74.15	74.15	48.78
		30°C	100.42	100.42	33.24	97.89	97.89	35.57	95.17	95.17	38.28	92.25	92.25	41.36	83.80	83.80	44.80	78.80	78.80	49.40
	19°C	24°C	105.33	69.84	33.67	102.05	68.32	35.97	98.55	66.71	38.62	94.83	65.01	41.63	85.42	59.43	44.99	79.42	56.39	49.48
		27°C	105.60	81.59	33.69	102.31	79.92	35.99	98.82	78.15	38.65	95.12	76.29	41.66	85.73	69.87	45.03	79.76	66.47	49.52
		30°C	106.00	99.56	33.73	102.66	97.76	36.03	99.14	95.86	38.69	95.40	93.87	41.71	86.02	86.02	45.08	80.08	80.08	49.57
		33°C	106.62	106.62	33.78	103.58	103.58	36.11	100.56	100.56	38.83	97.54	97.54	41.93	88.70	88.70	45.41	83.53	83.53	50.04
	22°C	27°C	115.56	65.62	34.59	111.91	64.17	36.93	108.11	62.68	39.62	104.10	61.11	42.66	93.89	55.91	46.06	87.42	53.11	50.57
		30°C	115.72	81.11	34.60	112.08	79.50	36.95	108.31	77.83	39.64	104.31	76.03	42.68	94.09	69.70	46.08	87.65	66.40	50.60
		33°C	116.05	94.52	34.63	112.42	92.83	36.98	108.63	91.07	39.68	104.62	89.23	42.73	94.39	82.07	46.12	87.95	78.52	50.65
		36°C	116.38	107.62	34.66	112.75	105.92	37.01	108.91	104.13	39.72	104.93	102.29	42.76	94.76	94.23	46.17	88.72	88.72	50.75
11000	16°C	21°C	97.88	76.90	33.02	94.75	75.27	35.28	91.37	73.47	37.90	87.80	71.47	40.88	79.02	65.18	44.22	73.33	61.61	48.67
		24°C	98.39	91.68	33.07	95.26	89.81	35.33	91.91	87.83	37.95	88.34	85.73	40.94	79.50	78.51	44.28	73.76	73.76	48.73
		27°C	99.07	99.07	33.12	96.14	96.14	35.41	93.13	93.13	38.08	90.12	90.12	41.13	81.73	81.73	44.55	76.67	76.67	49.11
		30°C	104.21	104.21	33.57	101.53	101.53	35.92	98.65	98.65	38.63	95.58	95.58	41.72	86.78	86.78	45.17	81.55	81.55	49.77
	19°C	24°C	107.47	72.59	33.86	104.07	71.07	36.16	100.42	69.43	38.82	96.56	67.72	41.82	86.95	61.96	45.19	80.85	58.85	49.66
		27°C	107.88	84.97	33.90	104.47	83.26	36.20	100.84	81.45	38.86	97.01	79.55	41.87	87.38	72.90	45.24	81.26	69.41	49.72
		30°C	108.37	104.22	33.94	104.91	102.38	36.25	101.25	100.45	38.91	97.44	97.44	41.92	87.84	87.84	45.30	81.92	81.92	49.82
		33°C	110.07	110.07	34.09	107.25	107.25	36.47	104.28	104.28	39.22	101.13	101.13	42.33	91.92	91.92	45.81	86.52	86.52	50.45
	22°C	27°C	117.79	68.15	34.79	114.02	66.70	37.14	110.08	65.20	39.83	105.92	63.63	42.87	95.49	58.28	46.26	88.88	55.46	50.77
		30°C	118.07	84.64	34.82	114.31	82.95	37.17	110.39	81.20	39.86	106.24	79.36	42.91	95.81	72.78	46.30	89.23	69.38	50.81
		33°C	118.52	98.98	34.86	114.77	97.26	37.21	110.81	95.46	39.91	106.66	93.58	42.96	96.19	86.13	46.35	89.59	82.48	50.87
		36°C	118.94	113.17	34.90	115.16	111.42	37.26	111.28	109.43	39.97	107.42	107.12	43.04	97.37	97.37	46.50	91.56	91.56	51.16
12100	16°C	21°C	99.62	79.00	33.17	96.36	77.17	35.43	92.91	75.22	38.06	89.27	73.15	41.04	80.29	66.70	44.37	74.47	63.04	48.83
		24°C	100.26	94.14	33.23	97.00	92.25	35.49	93.55	90.25	38.12	89.87	88.13	41.10	80.81	80.73	44.44	74.99	74.99	48.89
		27°C	101.66	101.66	33.34	98.83	98.83	35.66	95.92	95.92	38.36	92.81	92.81	41.42	84.12	84.12	44.84	78.87	78.87	49.40
		30°C	107.56	107.56	33.87	104.72	104.72	36.23	101.71	101.71	38.95	98.50	98.50	42.04	89.39	89.39	45.49	83.95	83.95	50.09
	19°C	24°C	109.27	75.97	34.02	105.74	74.41	36.32	101.99	72.76	38.98	98.03	70.99	41.99	88.26	64.87	45.34	82.00	61.46	49.82
		27°C	109.82	88.93	34.07	106.30	87.17	36.38	102.54	85.29	39.04	98.59	83.34	42.05	88.77	76.41	45.41	82.49	72.81	49.89
		30°C	110.39	109.58	34.12	106.79	106.79	36.44	103.12	103.12	39.10	99.27	99.27	42.12	89.70	89.70	45.53	83.97	83.97	50.10
		33°C	113.63	113.63	34.41	110.69	110.69	36.81	107.59	107.59	39.57	104.29	104.29	42.69	94.75	94.75	46.17	89.13	89.13	50.81
	22°C	27°C	119.66	71.29	34.96	115.79	69.83	37.31	111.72	68.31	40.00	107.47	66.75	43.04	96.85	61.22	46.43	90.11	58.25	50.94
		30°C	120.06	88.66	35.00	116.20	86.92	37.36	112.17	85.10	40.05	107.93	83.20	43.10	97.28	76.35	46.49	90.55	72.83	51.00
		33°C	120.63	104.12	35.06	116.74	102.35	37.41	112.67	100.50	40.11	108.40	98.57	43.16	97.70	90.77	46.55	90.95	86.99	51.07
		36°C	121.23	119.25	35.11	117.60	117.04	37.49	113.90	113.90	40.24	110.21	110.21	43.37	100.19	100.19	46.87	94.39	94.39	51.56

**Remark:**

AFR: Air flow rate (CFM)  
 EWB: Entering Wet Bulb Temp. (°C)  
 EDB: Entering Dry Bulb Temp. (°C)  
 TC: Total Cooling Capacity (kW)  
 SC: Sensible Cooling Capacity (kW)  
 PI: Power Input (kW)

**Notes:**

1. Ratings shown are net capacities.
2. ■ shows nominal capacities.
3. Direct interpolation is permissible. Do not extrapolate.
4. Unit is able to operate at ambient from 19°C to 46°C DB without pressure trip.

**Model: UATP420AGXY1**

**Cooling Mode**

AFR (CFM)	EWB	EDB	Outdoor temperature																	
			19°C			25°C			30°C			35°C			40°C			46°C		
			TC	SC	PI	TC	SC	PI	TC	SC	PI	TC	SC	PI	TC	SC	PI	TC	SC	PI
11250	16°C	21°C	120.19	94.95	38.28	116.39	92.86	40.91	112.34	90.64	43.96	107.99	88.28	47.44	97.18	80.60	51.33	90.28	76.24	56.52
		24°C	120.66	113.10	38.32	116.85	110.75	40.95	112.81	108.26	44.01	108.50	105.62	47.49	97.70	96.67	51.38	90.73	90.73	56.58
		27°C	121.11	121.11	38.36	117.41	117.41	41.00	113.47	113.47	44.07	109.44	109.44	47.59	99.07	99.07	51.54	92.97	92.97	56.85
		30°C	125.91	125.91	38.74	122.74	122.74	41.46	119.32	119.32	44.62	115.67	115.67	48.20	105.07	105.07	52.22	98.80	98.80	57.57
	19°C	24°C	132.06	89.70	39.24	127.95	87.75	41.92	123.55	85.68	45.01	118.89	83.50	48.52	107.10	76.33	52.44	99.58	72.43	57.67
		27°C	132.40	104.79	39.27	128.27	102.65	41.95	123.90	100.38	45.05	119.25	97.98	48.56	107.48	89.74	52.48	100.00	85.37	57.71
		30°C	132.90	127.88	39.31	128.72	125.56	42.00	124.29	123.12	45.10	119.61	119.61	48.61	107.85	107.85	52.54	100.40	100.40	57.77
		33°C	133.68	133.68	39.37	129.86	129.86	42.09	126.08	126.08	45.26	122.29	122.29	48.87	111.21	111.21	52.92	104.73	104.73	58.32
	22°C	27°C	144.89	84.28	40.31	140.31	82.42	43.04	135.54	80.50	46.18	130.52	78.49	49.72	117.72	71.81	53.68	109.60	68.21	58.94
		30°C	145.09	104.17	40.33	140.53	102.11	43.06	135.79	99.96	46.20	130.78	97.65	49.75	117.97	89.52	53.70	109.90	85.28	58.97
		33°C	145.50	121.39	40.36	140.95	119.22	43.10	136.19	116.97	46.25	131.17	114.60	49.80	118.35	105.41	53.76	110.28	100.85	59.03
		36°C	145.91	138.23	40.40	141.37	136.04	43.14	136.55	133.74	46.29	131.56	131.37	49.84	118.81	118.81	53.81	111.24	111.24	59.16
12500	16°C	21°C	122.73	98.77	38.49	118.79	96.67	41.12	114.55	94.36	44.17	110.08	91.79	47.65	99.07	83.72	51.54	91.94	79.13	56.72
		24°C	123.36	117.74	38.54	119.43	115.35	41.18	115.24	112.81	44.23	110.76	110.11	47.72	99.68	99.68	51.61	92.48	92.48	56.80
		27°C	124.22	124.22	38.60	120.54	120.54	41.27	116.77	116.77	44.38	113.00	113.00	47.94	102.47	102.47	51.92	96.13	96.13	57.24
		30°C	130.66	130.66	39.13	127.30	127.30	41.86	123.68	123.68	45.03	119.84	119.84	48.62	108.80	108.80	52.64	102.24	102.24	58.00
	19°C	24°C	134.75	93.24	39.46	130.48	91.27	42.14	125.90	89.18	45.24	121.06	86.98	48.74	109.02	79.58	52.67	101.37	75.58	57.88
		27°C	135.26	109.14	39.51	130.99	106.94	42.19	126.44	104.61	45.29	121.63	102.17	48.80	109.56	93.63	52.72	101.89	89.15	57.95
		30°C	135.87	133.86	39.56	131.53	131.50	42.25	126.94	126.94	45.35	122.16	122.16	48.86	110.13	110.13	52.79	102.71	102.71	58.07
		33°C	138.00	138.00	39.73	134.47	134.47	42.51	130.75	130.75	45.71	126.79	126.79	49.34	115.25	115.25	53.39	108.47	108.47	58.80
	22°C	27°C	147.68	87.53	40.55	142.95	85.67	43.28	138.02	83.75	46.42	132.80	81.72	49.97	119.72	74.85	53.91	111.44	71.23	59.17
		30°C	148.03	108.71	40.58	143.32	106.54	43.32	138.40	104.29	46.46	133.21	101.92	50.01	120.12	93.48	53.96	111.87	89.11	59.22
		33°C	148.60	127.13	40.63	143.90	124.92	43.37	138.94	122.61	46.52	133.72	120.19	50.07	120.60	110.62	54.03	112.32	105.94	59.29
		36°C	149.12	145.35	40.68	144.39	143.11	43.42	139.52	139.52	46.58	134.69	134.69	50.17	122.09	122.09	54.20	114.79	114.79	59.62
13750	16°C	21°C	124.90	101.46	38.66	120.81	99.11	41.30	116.48	96.61	44.36	111.93	93.96	47.83	100.67	85.67	51.71	93.37	80.97	56.91
		24°C	125.71	120.91	38.73	121.61	118.48	41.37	117.29	115.91	44.43	112.68	112.68	47.91	101.32	101.32	51.80	94.02	94.02	56.98
		27°C	127.46	127.46	38.86	123.92	123.92	41.57	120.27	120.27	44.70	116.36	116.36	48.27	105.47	105.47	52.26	98.89	98.89	57.58
		30°C	134.86	134.86	39.47	131.29	131.29	42.22	127.52	127.52	45.40	123.49	123.49	49.00	112.07	112.07	53.02	105.26	105.26	58.39
	19°C	24°C	137.00	97.57	39.65	132.58	95.58	42.33	127.88	93.45	45.43	122.91	91.17	48.94	110.66	83.31	52.84	102.81	78.94	58.07
		27°C	137.69	114.21	39.71	133.28	111.96	42.40	128.56	109.55	45.50	123.62	107.04	49.01	111.30	98.14	52.93	103.43	93.51	58.15
		30°C	138.41	138.41	39.77	133.89	133.89	42.47	129.29	129.29	45.57	124.46	124.46	49.10	112.46	112.46	53.07	105.28	105.28	58.39
		33°C	142.47	142.47	40.11	138.78	138.78	42.90	134.90	134.90	46.12	130.76	130.76	49.75	118.79	118.79	53.81	111.75	111.75	59.22
	22°C	27°C	150.03	91.56	40.75	145.17	89.69	43.49	140.07	87.73	46.62	134.75	85.73	50.17	121.43	78.62	54.11	112.97	74.81	59.37
		30°C	150.53	113.87	40.80	145.69	111.63	43.54	140.64	109.30	46.68	135.32	106.86	50.23	121.97	98.06	54.18	113.54	93.54	59.44
		33°C	151.25	133.73	40.86	146.37	131.45	43.60	141.27	129.08	46.75	135.91	126.60	50.31	122.49	116.58	54.26	114.03	111.73	59.52
		36°C	152.00	152.00	40.92	147.45	147.45	43.70	142.80	142.80	46.90	138.19	138.19	50.55	125.62	125.62	54.63	118.35	118.35	60.09

**Remark:**

AFR: Air flow rate (CFM)  
 EWB: Entering Wet Bulb Temp. (°C)  
 EDB: Entering Dry Bulb Temp. (°C)  
 TC: Total Cooling Capacity (kW)  
 SC: Sensible Cooling Capacity (kW)  
 PI: Power Input (kW)

**Notes:**

1. Ratings shown are net capacities.
2. ■ shows nominal capacities.
3. Direct interpolation is permissible. Do not extrapolate.
4. Unit is able to operate at ambient from 19°C to 46°C DB without pressure trip.

### R407C Heatpump

Model: UATYP60AGXY1

Cooling Mode

AFR (CFM)	EWB	EDB	Outdoor temperature																	
			19°C			25°C			30°C			35°C			40°C			46°C		
			TC	SC	PI	TC	SC	PI	TC	SC	PI	TC	SC	PI	TC	SC	PI	TC	SC	PI
1620	16°C	21°C	16.22	10.68	5.22	15.70	10.44	5.58	15.16	10.19	5.99	14.57	9.93	6.46	13.11	9.06	6.99	12.18	8.57	7.70
		24°C	16.28	12.72	5.22	15.77	12.45	5.58	15.22	12.17	6.00	14.64	11.88	6.47	13.18	10.87	7.00	12.24	10.33	7.71
		27°C	16.34	14.64	5.23	15.84	14.36	5.59	15.31	14.07	6.01	14.77	13.70	6.48	13.37	12.48	7.02	12.54	11.72	7.75
		30°C	16.99	16.99	5.28	16.56	16.56	5.65	16.10	16.10	6.08	15.61	15.61	6.57	14.18	14.18	7.12	13.33	13.33	7.85
	19°C	24°C	17.82	10.09	5.35	17.26	9.87	5.71	16.67	9.63	6.13	16.04	9.39	6.61	14.45	8.58	7.15	13.43	8.14	7.86
		27°C	17.86	11.78	5.35	17.31	11.54	5.72	16.72	11.29	6.14	16.09	11.02	6.62	14.50	10.09	7.15	13.49	9.60	7.86
		30°C	17.93	14.38	5.36	17.37	14.12	5.72	16.77	13.84	6.15	16.14	13.55	6.62	14.55	12.46	7.16	13.55	11.91	7.87
		33°C	18.04	18.04	5.37	17.52	17.52	5.74	17.01	17.01	6.17	16.50	16.50	6.66	15.00	15.00	7.21	14.13	14.13	7.95
	22°C	27°C	19.55	9.48	5.49	18.93	9.27	5.87	18.29	9.05	6.29	17.61	8.83	6.78	15.88	8.07	7.31	14.79	7.67	8.03
		30°C	19.58	11.71	5.50	18.96	11.48	5.87	18.32	11.24	6.30	17.64	10.98	6.78	15.92	10.06	7.32	14.83	9.59	8.04
		33°C	19.63	13.65	5.50	19.02	13.40	5.87	18.37	13.15	6.30	17.70	12.88	6.79	15.97	11.85	7.33	14.88	11.34	8.04
		36°C	19.69	15.54	5.51	19.07	15.30	5.88	18.42	15.04	6.31	17.75	14.77	6.79	16.03	13.61	7.33	15.01	12.97	8.06
1800	16°C	21°C	16.56	11.11	5.24	16.03	10.87	5.60	15.46	10.61	6.02	14.85	10.32	6.49	13.37	9.41	7.02	12.40	8.90	7.73
		24°C	16.64	13.24	5.25	16.11	12.97	5.61	15.55	12.68	6.03	14.94	12.38	6.50	13.45	11.34	7.03	12.48	10.78	7.74
		27°C	16.76	15.35	5.26	16.26	15.02	5.62	15.75	14.63	6.05	15.25	14.17	6.53	13.83	12.92	7.08	12.97	12.15	7.80
		30°C	17.63	17.63	5.33	17.17	17.17	5.70	16.69	16.69	6.14	16.17	16.17	6.63	14.68	14.68	7.17	13.79	13.79	7.90
	19°C	24°C	18.18	10.48	5.38	17.60	10.26	5.74	16.99	10.03	6.16	16.33	9.78	6.64	14.71	8.95	7.18	13.68	8.50	7.89
		27°C	18.25	12.27	5.38	17.67	12.02	5.75	17.06	11.76	6.17	16.41	11.49	6.65	14.78	10.53	7.18	13.75	10.02	7.90
		30°C	18.33	15.05	5.39	17.75	14.78	5.76	17.13	14.50	6.18	16.48	14.22	6.66	14.86	13.07	7.19	13.86	12.43	7.91
		33°C	18.62	18.62	5.41	18.14	18.14	5.79	17.64	17.64	6.23	17.11	17.11	6.72	15.55	15.55	7.28	14.63	14.63	8.01
	22°C	27°C	19.92	9.84	5.53	19.29	9.63	5.90	18.62	9.42	6.33	17.92	9.19	6.81	16.15	8.42	7.35	15.04	8.01	8.06
		30°C	19.97	12.22	5.53	19.34	11.98	5.90	18.67	11.73	6.33	17.97	11.46	6.81	16.21	10.51	7.35	15.09	10.02	8.07
		33°C	20.05	14.29	5.54	19.41	14.05	5.91	18.74	13.78	6.34	18.04	13.51	6.82	16.27	12.44	7.36	15.15	11.91	8.08
		36°C	20.12	16.34	5.54	19.48	16.09	5.92	18.82	15.80	6.35	18.17	15.47	6.84	16.47	14.30	7.39	15.49	13.63	8.12
1980	16°C	21°C	16.85	11.41	5.27	16.30	11.14	5.63	15.72	10.86	6.04	15.10	10.56	6.52	13.58	9.63	7.05	12.60	9.10	7.75
		24°C	16.96	13.59	5.28	16.41	13.32	5.64	15.82	13.03	6.05	15.20	12.73	6.53	13.67	11.66	7.06	12.68	11.10	7.77
		27°C	17.20	15.84	5.30	16.72	15.58	5.66	16.23	15.28	6.09	15.70	14.93	6.58	14.23	13.58	7.12	13.34	12.79	7.85
		30°C	18.20	18.20	5.38	17.71	17.71	5.75	17.20	17.20	6.19	16.66	16.66	6.68	15.12	15.12	7.23	14.20	14.20	7.96
	19°C	24°C	18.48	10.97	5.40	17.89	10.75	5.77	17.25	10.51	6.19	16.58	10.25	6.67	14.93	9.37	7.20	13.87	8.88	7.91
		27°C	18.58	12.84	5.41	17.98	12.59	5.78	17.34	12.32	6.20	16.68	12.03	6.68	15.02	11.03	7.21	13.95	10.51	7.92
		30°C	18.67	15.82	5.42	18.06	15.55	5.79	17.44	15.26	6.21	16.79	14.93	6.69	15.17	13.65	7.23	14.20	12.89	7.96
		33°C	19.22	19.22	5.47	18.72	18.72	5.85	18.20	18.20	6.28	17.64	17.64	6.78	16.03	16.03	7.33	15.08	15.08	8.07
	22°C	27°C	20.24	10.29	5.55	19.59	10.08	5.93	18.90	9.86	6.35	18.18	9.64	6.84	16.38	8.84	7.37	15.24	8.41	8.09
		30°C	20.31	12.80	5.56	19.66	12.55	5.93	18.97	12.29	6.36	18.26	12.01	6.84	16.46	11.02	7.38	15.32	10.52	8.10
		33°C	20.41	15.04	5.57	19.75	14.78	5.94	19.06	14.51	6.37	18.34	14.23	6.86	16.53	13.11	7.39	15.39	12.56	8.11
		36°C	20.51	17.22	5.58	19.89	16.90	5.95	19.27	16.53	6.39	18.64	16.10	6.89	16.95	14.80	7.44	15.97	14.06	8.19

Model: UATYP60AGXY1

Heating Mode

Indoor DB°C	Outdoor WB°C													
	-9		-6		-5		6		12		15		18	
	TC	SC	TC	SC	TC	SC	TC	SC	TC	SC	TC	SC	TC	SC
15	12.225	12.225	13.837	13.837	14.374	14.374	20.283	20.283	23.506	23.506	25.118	25.118	26.730	26.730
17	11.905	11.905	14.047	14.047	14.092	14.092	20.259	20.259	23.390	23.390	25.030	25.030	26.671	26.671
19	11.584	11.584	14.256	14.256	13.811	13.811	20.235	20.235	23.273	23.273	24.943	24.943	26.612	26.612
21	11.264	11.264	14.036	14.036	13.529	13.529	20.081	20.081	23.156	23.156	24.855	24.855	26.554	26.554
23	10.943	10.943	13.387	13.387	13.247	13.247	19.799	19.799	23.039	23.039	24.767	24.767	26.495	26.495
25	10.623	10.623	12.738	12.738	12.965	12.965	19.516	19.516	22.922	22.922	24.679	24.679	26.436	26.436
27	10.302	10.302	12.088	12.088	12.684	12.684	19.233	19.233	22.805	22.805	24.591	24.591	26.377	26.377
Frost Region														

**Remark:**

- AFR: Air flow rate (CFM)
- EWB: Entering Wet Bulb Temp. (°C)
- EDB: Entering Dry Bulb Temp. (°C)
- TC: Total Cooling / Heating Capacity (kW)
- SC: Sensible Cooling / Heating Capacity (kW)
- PI: Power Input (kW)

**Notes:**

1. Ratings shown are gross capacities which do not include a deduction for indoor fan motor heat.
2. ■ shows nominal capacities.
3. Direct interpolation is permissible. Do not extrapolate.
4. Unit is able to operate at ambient from 19°C to 46°C DB (cooling) / -9°C to 18°C WB (heating) without pressure trip.

**Model: UATYP80AGXY1**

**Cooling Mode**

AFR (CFM)	EWB	EDB	Outdoor temperature																	
			19°C			25°C			30°C			35°C			40°C			46°C		
			TC	SC	PI	TC	SC	PI	TC	SC	PI	TC	SC	PI	TC	SC	PI	TC	SC	PI
2543	16°C	21°C	20.85	15.30	6.60	20.19	14.96	7.05	19.49	14.60	7.58	18.73	14.22	8.18	16.86	12.98	8.85	15.66	12.28	9.74
		24°C	20.93	18.22	6.60	20.27	17.84	7.06	19.57	17.44	7.58	18.82	17.01	8.18	16.95	15.57	8.86	15.74	14.80	9.75
		27°C	21.01	20.97	6.61	20.37	20.37	7.07	19.68	19.68	7.59	18.99	18.99	8.20	17.19	17.19	8.88	16.13	16.13	9.80
		30°C	21.84	21.84	6.68	21.29	21.29	7.15	20.70	20.70	7.69	20.07	20.07	8.31	18.23	18.23	9.00	17.14	17.14	9.92
	19°C	24°C	22.91	14.45	6.76	22.20	14.14	7.22	21.43	13.80	7.76	20.62	13.45	8.36	18.58	12.30	9.04	17.27	11.67	9.94
		27°C	22.97	16.88	6.77	22.25	16.54	7.23	21.49	16.17	7.76	20.69	15.78	8.37	18.65	14.46	9.04	17.35	13.75	9.95
		30°C	23.06	20.60	6.77	22.33	20.23	7.24	21.56	19.83	7.77	20.75	19.42	8.38	18.71	17.85	9.05	17.42	17.07	9.96
		33°C	23.19	23.19	6.79	22.53	22.53	7.25	21.87	21.87	7.80	21.21	21.21	8.42	19.29	19.29	9.12	18.17	18.17	10.05
	22°C	27°C	25.14	13.58	6.95	24.34	13.28	7.42	23.51	12.97	7.96	22.64	12.64	8.57	20.42	11.57	9.25	19.01	10.99	10.16
		30°C	25.17	16.78	6.95	24.38	16.45	7.42	23.56	16.10	7.96	22.69	15.73	8.57	20.46	14.42	9.26	19.06	13.74	10.16
		33°C	25.24	19.55	6.96	24.45	19.21	7.43	23.63	18.84	7.97	22.76	18.46	8.58	20.53	16.98	9.26	19.13	16.25	10.17
		36°C	25.31	22.27	6.96	24.52	21.91	7.43	23.69	21.54	7.98	22.82	21.16	8.59	20.61	19.49	9.27	19.30	18.58	10.19
2826	16°C	21°C	21.29	15.91	6.63	20.61	15.57	7.09	19.87	15.20	7.61	19.10	14.79	8.21	17.19	13.49	8.88	15.95	12.75	9.77
		24°C	21.40	18.97	6.64	20.72	18.58	7.10	19.99	18.17	7.62	19.21	17.74	8.22	17.29	16.24	8.89	16.04	15.44	9.79
		27°C	21.55	21.55	6.65	20.91	20.91	7.11	20.26	20.26	7.65	19.60	19.60	8.26	17.78	17.78	8.95	16.68	16.68	9.86
		30°C	22.67	22.67	6.74	22.08	22.08	7.21	21.46	21.46	7.76	20.79	20.79	8.38	18.87	18.87	9.07	17.74	17.74	10.00
	19°C	24°C	23.38	15.02	6.80	22.64	14.70	7.26	21.84	14.37	7.80	21.00	14.01	8.40	18.91	12.82	9.08	17.59	12.18	9.98
		27°C	23.46	17.58	6.81	22.72	17.23	7.27	21.93	16.85	7.80	21.10	16.46	8.41	19.01	15.08	9.09	17.68	14.36	9.99
		30°C	23.57	21.56	6.82	22.82	21.18	7.28	22.02	20.78	7.82	21.19	20.37	8.42	19.11	18.72	9.10	17.82	17.80	10.01
		33°C	23.94	23.94	6.85	23.33	23.33	7.33	22.68	22.68	7.88	22.00	22.00	8.50	19.99	19.99	9.20	18.82	18.82	10.13
	22°C	27°C	25.62	14.10	6.99	24.80	13.80	7.46	23.94	13.49	8.00	23.04	13.16	8.61	20.77	12.06	9.29	19.33	11.47	10.20
		30°C	25.68	17.51	6.99	24.86	17.16	7.47	24.01	16.80	8.01	23.11	16.42	8.62	20.84	15.06	9.30	19.41	14.35	10.21
		33°C	25.78	20.48	7.00	24.96	20.12	7.47	24.10	19.75	8.02	23.20	19.36	8.63	20.92	17.82	9.31	19.49	17.07	10.22
		36°C	25.87	23.41	7.01	25.05	23.05	7.48	24.20	22.64	8.03	23.37	22.16	8.65	21.18	20.49	9.34	19.91	19.53	10.28
3109	16°C	21°C	21.67	16.34	6.66	20.96	15.97	7.12	20.21	15.56	7.64	19.42	15.14	8.24	17.46	13.80	8.91	16.20	13.04	9.81
		24°C	21.81	19.48	6.67	21.10	19.09	7.13	20.35	18.67	7.66	19.55	18.23	8.26	17.58	16.70	8.93	16.31	15.90	9.82
		27°C	22.11	22.11	6.70	21.50	21.50	7.16	20.86	20.86	7.70	20.19	20.19	8.32	18.30	18.30	9.01	17.16	17.16	9.92
		30°C	23.40	23.40	6.80	22.78	22.78	7.28	22.12	22.12	7.82	21.42	21.42	8.44	19.44	19.44	9.14	18.26	18.26	10.06
	19°C	24°C	23.77	15.72	6.83	23.00	15.40	7.30	22.18	15.05	7.83	21.32	14.69	8.43	19.20	13.42	9.11	17.84	12.72	10.01
		27°C	23.89	18.40	6.84	23.12	18.03	7.31	22.30	17.65	7.84	21.44	17.24	8.45	19.31	15.81	9.12	17.94	15.06	10.02
		30°C	24.01	22.67	6.85	23.23	22.28	7.32	22.43	21.86	7.85	21.59	21.39	8.46	19.51	19.51	9.15	18.26	18.26	10.06
		33°C	24.72	24.72	6.91	24.08	24.08	7.39	23.40	23.40	7.95	22.68	22.68	8.57	20.61	20.61	9.27	19.39	19.39	10.21
	22°C	27°C	26.03	14.75	7.02	25.18	14.45	7.49	24.30	14.13	8.04	23.38	13.81	8.65	21.07	12.67	9.33	19.60	12.05	10.23
		30°C	26.11	18.34	7.03	25.27	17.98	7.50	24.40	17.61	8.04	23.48	17.21	8.66	21.16	15.80	9.34	19.70	15.07	10.24
		33°C	26.24	21.54	7.04	25.39	21.17	7.51	24.51	20.79	8.06	23.58	20.39	8.67	21.25	18.78	9.35	19.78	18.00	10.26
		36°C	26.37	24.67	7.05	25.58	24.21	7.53	24.77	23.68	8.08	23.97	23.06	8.71	21.79	21.21	9.42	20.53	20.14	10.36

**Model: UATYP80AGXY1**

**Heating Mode**

Indoor DB°C	Outdoor WB°C													
	-9		-6		-5		6		12		15		18	
	TC	SC	TC	SC	TC	SC	TC	SC	TC	SC	TC	SC	TC	SC
15	13.643	13.643	15.441	15.441	16.041	16.041	22.635	22.635	26.232	26.232	28.030	28.030	29.829	29.829
17	13.285	13.285	14.130	14.130	15.690	15.690	22.608	22.608	25.914	25.914	27.718	27.718	29.522	29.522
19	12.927	12.927	12.819	12.819	15.340	15.340	22.581	22.581	25.596	25.596	27.406	27.406	29.216	29.216
21	12.570	12.570	12.330	12.330	14.990	14.990	22.295	22.295	25.278	25.278	27.094	27.094	28.909	28.909
23	12.212	12.212	12.663	12.663	14.640	14.640	21.750	21.750	24.960	24.960	26.781	26.781	28.603	28.603
25	11.854	11.854	12.996	12.996	14.290	14.290	21.205	21.205	24.642	24.642	26.469	26.469	28.296	28.296
27	11.497	11.497	13.329	13.329	13.940	13.940	20.659	20.659	24.324	24.324	26.157	26.157	27.989	27.989
Frost Region														

**Remark:**

- AFR: Air flow rate (CFM)
- EWB: Entering Wet Bulb Temp. (°C)
- EDB: Entering Dry Bulb Temp. (°C)
- TC: Total Cooling / Heating Capacity (kW)
- SC: Sensible Cooling / Heating Capacity (kW)
- PI: Power Input (kW)

**Notes:**

1. Ratings shown are gross capacities which do not include a deduction for indoor fan motor heat.
2. ■ shows nominal capacities.
3. Direct interpolation is permissible. Do not extrapolate.
4. Unit is able to operate at ambient from 19°C to 46°C DB (cooling) / -9°C to 18°C WB (heating) without pressure trip.

**Model: UATYP100AGXY1**

**Cooling Mode**

AFR (CFM)	EWB	EDB	Outdoor temperature																	
			19°C			25°C			30°C			35°C			40°C			46°C		
			TC	SC	PI	TC	SC	PI	TC	SC	PI	TC	SC	PI	TC	SC	PI	TC	SC	PI
3179	16°C	21°C	25.49	19.41	8.49	24.68	18.99	9.07	23.82	18.53	9.75	22.90	18.05	10.52	20.61	16.48	11.38	19.14	15.59	12.53
		24°C	25.58	23.13	8.50	24.78	22.64	9.08	23.92	22.14	9.76	23.01	21.60	10.53	20.72	19.77	11.39	19.24	18.78	12.54
		27°C	25.68	25.68	8.51	24.90	24.90	9.09	24.06	24.06	9.77	23.21	23.21	10.55	21.01	21.01	11.43	19.71	19.71	12.61
		30°C	26.70	26.70	8.59	26.02	26.02	9.19	25.30	25.30	9.89	24.53	24.53	10.69	22.28	22.28	11.58	20.95	20.95	12.77
	19°C	24°C	28.00	18.34	8.70	27.13	17.94	9.29	26.20	17.52	9.98	25.21	17.07	10.76	22.71	15.61	11.63	21.11	14.81	12.79
		27°C	28.07	21.43	8.71	27.20	20.99	9.30	26.27	20.52	9.99	25.29	20.03	10.77	22.79	18.35	11.64	21.20	17.45	12.80
		30°C	28.18	26.15	8.72	27.29	25.67	9.31	26.36	25.17	10.00	25.36	24.65	10.78	22.87	22.66	11.65	21.29	21.29	12.81
		33°C	28.34	28.34	8.73	27.54	27.54	9.33	26.73	26.73	10.04	25.93	25.93	10.84	23.58	23.58	11.73	22.21	22.21	12.93
	22°C	27°C	30.72	17.23	8.94	29.75	16.85	9.54	28.74	16.46	10.24	27.68	16.05	11.02	24.96	14.68	11.90	23.24	13.95	13.07
		30°C	30.76	21.30	8.94	29.80	20.88	9.55	28.79	20.44	10.24	27.73	19.97	11.03	25.01	18.30	11.91	23.30	17.44	13.08
		33°C	30.85	24.82	8.95	29.89	24.38	9.56	28.88	23.92	10.25	27.81	23.43	11.04	25.09	21.55	11.92	23.38	20.62	13.09
		36°C	30.94	28.26	8.96	29.97	27.82	9.57	28.95	27.35	10.26	27.90	26.86	11.05	25.19	24.74	11.93	23.59	23.58	13.12
3532	16°C	21°C	26.02	20.20	8.53	25.19	19.77	9.12	24.29	19.29	9.79	23.34	18.77	10.57	21.01	17.12	11.43	19.50	16.18	12.58
		24°C	26.16	24.07	8.55	25.32	23.58	9.13	24.43	23.06	9.81	23.48	22.51	10.58	21.13	20.62	11.44	19.61	19.60	12.59
		27°C	26.34	26.34	8.56	25.56	25.56	9.15	24.76	24.76	9.84	23.96	23.96	10.63	21.73	21.73	11.51	20.38	20.38	12.69
		30°C	27.70	27.70	8.68	26.99	26.99	9.28	26.23	26.23	9.98	25.41	25.41	10.78	23.07	23.07	11.67	21.68	21.68	12.86
	19°C	24°C	28.57	19.06	8.75	27.67	18.66	9.34	26.70	18.23	10.03	25.67	17.78	10.81	23.12	16.27	11.68	21.49	15.45	12.83
		27°C	28.68	22.31	8.76	27.77	21.87	9.35	26.81	21.39	10.04	25.79	20.89	10.82	23.23	19.14	11.69	21.60	18.23	12.85
		30°C	28.81	27.37	8.77	27.89	26.89	9.37	26.92	26.38	10.06	25.90	25.85	10.83	23.35	23.35	11.71	21.78	21.78	12.87
		33°C	29.26	29.26	8.81	28.51	28.51	9.42	27.72	27.72	10.14	26.89	26.89	10.94	24.44	24.44	11.84	23.00	23.00	13.04
	22°C	27°C	31.31	17.90	8.99	30.31	17.52	9.60	29.27	17.12	10.29	28.16	16.71	11.08	25.39	15.30	11.95	23.63	14.56	13.12
		30°C	31.39	22.23	9.00	30.39	21.78	9.60	29.35	21.32	10.30	28.24	20.84	11.09	25.47	19.11	11.96	23.72	18.22	13.13
		33°C	31.51	25.99	9.01	30.51	25.54	9.62	29.46	25.07	10.31	28.35	24.57	11.10	25.57	22.62	11.98	23.82	21.66	13.15
		36°C	31.62	29.72	9.02	30.62	29.26	9.63	29.58	28.74	10.33	28.56	28.13	11.12	25.89	25.89	12.02	24.34	24.34	13.22
3885	16°C	21°C	26.48	20.75	8.57	25.62	20.26	9.16	24.70	19.75	9.83	23.73	19.21	10.60	21.34	17.52	11.47	19.80	16.56	12.62
		24°C	26.65	24.72	8.59	25.79	24.22	9.17	24.87	23.70	9.85	23.89	23.14	10.62	21.48	21.20	11.48	19.94	19.94	12.63
		27°C	27.03	27.03	8.62	26.27	26.27	9.22	25.50	25.50	9.91	24.67	24.67	10.70	22.36	22.36	11.59	20.97	20.97	12.77
		30°C	28.60	28.60	8.75	27.84	27.84	9.36	27.04	27.04	10.07	26.19	26.19	10.86	23.76	23.76	11.76	22.32	22.32	12.95
	19°C	24°C	29.05	19.95	8.79	28.11	19.54	9.39	27.11	19.11	10.07	26.06	18.64	10.85	23.46	17.03	11.72	21.80	16.14	12.88
		27°C	29.20	23.35	8.80	28.26	22.89	9.40	27.26	22.40	10.09	26.21	21.89	10.87	23.60	20.07	11.74	21.93	19.12	12.89
		30°C	29.35	28.78	8.82	28.39	28.28	9.42	27.41	27.41	10.10	26.39	26.39	10.89	23.85	23.85	11.77	22.32	22.32	12.95
		33°C	30.21	30.21	8.89	29.43	29.43	9.51	28.60	28.60	10.23	27.73	27.73	11.03	25.19	25.19	11.93	23.70	23.70	13.13
	22°C	27°C	31.81	18.72	9.03	30.78	18.34	9.64	29.70	17.94	10.34	28.57	17.53	11.12	25.75	16.08	12.00	23.95	15.30	13.16
		30°C	31.92	23.28	9.05	30.89	22.82	9.65	29.82	22.35	10.35	28.69	21.85	11.14	25.86	20.05	12.01	24.07	19.13	13.18
		33°C	32.07	27.34	9.06	31.03	26.88	9.67	29.95	26.39	10.37	28.82	25.88	11.15	25.97	23.84	12.03	24.18	22.85	13.20
		36°C	32.23	31.31	9.07	31.26	30.74	9.69	30.28	30.06	10.40	29.30	29.28	11.21	26.64	26.64	12.11	25.09	25.09	13.32

**Model: UATYP100AGXY1**

**Heating Mode**

Indoor DB°C	Outdoor WB°C													
	-9		-6		-5		6		12		15		18	
	TC	SC	TC	SC	TC	SC	TC	SC	TC	SC	TC	SC	TC	SC
15	18.072	18.072	20.454	20.454	21.249	21.249	29.984	29.984	34.749	34.749	37.131	37.131	39.513	39.513
17	17.598	17.598	18.720	18.720	20.839	20.839	29.948	29.948	34.612	34.612	37.043	37.043	39.473	39.473
19	17.124	17.124	16.987	16.987	20.430	20.430	29.912	29.912	34.476	34.476	36.955	36.955	39.433	39.433
21	16.651	16.651	16.374	16.374	20.020	20.020	29.708	29.708	34.339	34.339	36.866	36.866	39.393	39.393
23	16.177	16.177	16.883	16.883	19.610	19.610	29.334	29.334	34.203	34.203	36.778	36.778	39.353	39.353
25	15.703	15.703	17.392	17.392	19.201	19.201	28.961	28.961	34.067	34.067	36.690	36.690	39.313	39.313
27	15.229	15.229	17.901	17.901	18.791	18.791	28.587	28.587	33.930	33.930	36.602	36.602	39.273	39.273
Frost Region														

**Remark:**

- AFR: Air flow rate (CFM)
- EWB: Entering Wet Bulb Temp. (°C)
- EDB: Entering Dry Bulb Temp. (°C)
- TC: Total Cooling / Heating Capacity (kW)
- SC: Sensible Cooling / Heating Capacity (kW)
- PI: Power Input (kW)

**Notes:**

1. Ratings shown are gross capacities which do not include a deduction for indoor fan motor heat.
2. ■ shows nominal capacities.
3. Direct interpolation is permissible. Do not extrapolate.
4. Unit is able to operate at ambient from 19°C to 46°C DB (cooling) / -9°C to 18°C WB (heating) without pressure trip.

**Model: UATYP120AGXY1**

**Cooling Mode**

AFR (CFM)	EWB	EDB	Outdoor temperature																	
			19°C			25°C			30°C			35°C			40°C			46°C		
			TC	SC	PI	TC	SC	PI	TC	SC	PI	TC	SC	PI	TC	SC	PI	TC	SC	PI
3240	16°C	21°C	28.96	22.88	10.05	28.05	22.38	10.74	27.07	21.84	11.54	26.02	21.27	12.45	23.42	19.42	13.47	21.75	18.37	14.84
		24°C	29.08	27.25	10.06	28.16	26.69	10.75	27.19	26.09	11.55	26.15	25.45	12.47	23.54	23.30	13.49	21.86	21.86	14.85
		27°C	29.18	29.18	10.07	28.29	28.29	10.76	27.34	27.34	11.57	26.37	26.37	12.49	23.87	23.87	13.53	22.40	22.40	14.92
		30°C	30.34	30.34	10.17	29.58	29.58	10.88	28.75	28.75	11.71	27.87	27.87	12.65	25.32	25.32	13.71	23.81	23.81	15.11
	19°C	24°C	31.82	21.62	10.30	30.83	21.15	11.00	29.77	20.65	11.82	28.65	20.12	12.74	25.81	18.39	13.77	24.00	17.45	15.14
		27°C	31.90	25.25	10.31	30.91	24.74	11.01	29.86	24.19	11.82	28.74	23.61	12.75	25.90	21.62	13.78	24.10	20.57	15.15
		30°C	32.03	30.82	10.32	31.02	30.26	11.02	29.95	29.67	11.84	28.82	28.82	12.76	25.99	25.99	13.79	24.19	24.19	15.17
		33°C	32.21	32.21	10.33	31.29	31.29	11.05	30.38	30.38	11.88	29.47	29.47	12.83	26.80	26.80	13.89	25.24	25.24	15.31
	22°C	27°C	34.92	20.31	10.58	33.81	19.86	11.30	32.66	19.40	12.12	31.45	18.91	13.05	28.37	17.31	14.09	26.41	16.44	15.47
		30°C	34.96	25.10	10.59	33.86	24.61	11.30	32.72	24.09	12.13	31.51	23.53	13.06	28.43	21.57	14.10	26.48	20.55	15.48
		33°C	35.06	29.25	10.60	33.97	28.73	11.31	32.82	28.19	12.14	31.61	27.62	13.07	28.52	25.40	14.11	26.57	24.30	15.50
		36°C	35.16	33.31	10.61	34.07	32.78	11.32	32.90	32.23	12.15	31.70	31.66	13.08	28.63	28.63	14.13	26.81	26.81	15.53
3600	16°C	21°C	29.57	23.80	10.10	28.63	23.30	10.79	27.61	22.74	11.60	26.53	22.12	12.51	23.87	20.17	13.53	22.16	19.07	14.89
		24°C	29.73	28.37	10.12	28.78	27.80	10.81	27.77	27.18	11.61	26.69	26.53	12.53	24.02	24.02	13.55	22.29	22.29	14.91
		27°C	29.93	29.93	10.13	29.05	29.05	10.83	28.14	28.14	11.65	27.23	27.23	12.58	24.69	24.69	13.63	23.17	23.17	15.03
		30°C	31.49	31.49	10.27	30.68	30.68	10.99	29.80	29.80	11.82	28.88	28.88	12.76	26.22	26.22	13.82	24.64	24.64	15.23
	19°C	24°C	32.47	22.47	10.36	31.44	21.99	11.06	30.34	21.49	11.88	29.17	20.96	12.79	26.27	19.18	13.82	24.43	18.21	15.19
		27°C	32.59	26.30	10.37	31.56	25.77	11.07	30.47	25.21	11.89	29.31	24.62	12.81	26.40	22.56	13.84	24.55	21.48	15.21
		30°C	32.74	32.26	10.38	31.70	31.69	11.09	30.59	30.59	11.90	29.44	29.44	12.83	26.54	26.54	13.86	24.75	24.75	15.24
		33°C	33.25	33.25	10.43	32.40	32.40	11.16	31.51	31.51	12.00	30.55	30.55	12.95	27.77	27.77	14.02	26.14	26.14	15.44
	22°C	27°C	35.59	21.09	10.64	34.45	20.64	11.36	33.26	20.18	12.19	32.00	19.69	13.12	28.85	18.04	14.15	26.85	17.16	15.53
		30°C	35.67	26.20	10.65	34.54	25.67	11.37	33.35	25.13	12.20	32.10	24.56	13.13	28.95	22.53	14.16	26.96	21.47	15.55
		33°C	35.81	30.64	10.67	34.68	30.10	11.39	33.48	29.55	12.21	32.22	28.96	13.14	29.06	26.66	14.18	27.07	25.53	15.56
		36°C	35.93	35.03	10.68	34.79	34.49	11.40	33.62	33.62	12.23	32.46	32.46	13.17	29.42	29.42	14.23	27.66	27.66	15.65
3960	16°C	21°C	30.10	24.45	10.15	29.11	23.88	10.84	28.07	23.28	11.64	26.97	22.64	12.56	24.26	20.64	13.57	22.50	19.51	14.94
		24°C	30.29	29.14	10.17	29.31	28.55	10.86	28.26	27.93	11.66	27.15	27.15	12.58	24.42	24.42	13.60	22.66	22.66	14.96
		27°C	30.72	30.72	10.20	29.86	29.86	10.91	28.98	28.98	11.73	28.04	28.04	12.67	25.42	25.42	13.72	23.83	23.83	15.12
		30°C	32.50	32.50	10.36	31.64	31.64	11.08	30.73	30.73	11.92	29.76	29.76	12.86	27.01	27.01	13.92	25.36	25.36	15.33
	19°C	24°C	33.01	23.51	10.41	31.95	23.03	11.11	30.82	22.52	11.92	29.62	21.97	12.85	26.67	20.08	13.87	24.78	19.02	15.24
		27°C	33.18	27.52	10.42	32.12	26.98	11.13	30.98	26.40	11.94	29.79	25.79	12.86	26.82	23.65	13.89	24.92	22.53	15.27
		30°C	33.35	33.35	10.44	32.26	32.26	11.15	31.16	31.16	11.96	29.99	29.99	12.89	27.10	27.10	13.93	25.37	25.37	15.33
		33°C	34.33	34.33	10.53	33.44	33.44	11.26	32.51	32.51	12.11	31.51	31.51	13.06	28.63	28.63	14.13	26.93	26.93	15.55
	22°C	27°C	36.15	22.06	10.70	34.98	21.61	11.42	33.75	21.14	12.24	32.47	20.66	13.17	29.26	18.95	14.20	27.22	18.03	15.58
		30°C	36.27	27.44	10.71	35.11	26.90	11.43	33.89	26.34	12.25	32.61	25.75	13.19	29.39	23.63	14.22	27.36	22.54	15.60
		33°C	36.45	32.23	10.73	35.27	31.68	11.45	34.04	31.10	12.27	32.75	30.51	13.21	29.52	28.09	14.24	27.48	26.92	15.62
		36°C	36.63	36.63	10.74	35.53	35.53	11.47	34.41	34.41	12.31	33.30	33.30	13.27	30.27	30.27	14.34	28.52	28.52	15.77

**Model: UATYP120AGXY1**

**Heating Mode**

Indoor DB°C	Outdoor WB°C													
	-9		-6		-5		6		12		15		18	
	TC	SC	TC	SC	TC	SC	TC	SC	TC	SC	TC	SC	TC	SC
15	21.616	21.616	24.465	24.465	25.415	25.415	35.863	35.863	41.562	41.562	44.412	44.412	47.261	47.261
17	21.049	21.049	22.651	22.651	24.807	24.807	35.820	35.820	40.781	40.781	43.600	43.600	46.418	46.418
19	20.482	20.482	20.837	20.837	24.200	24.200	35.778	35.778	39.999	39.999	42.787	42.787	45.575	45.575
21	19.916	19.916	20.066	20.066	23.592	23.592	35.154	35.154	39.218	39.218	41.975	41.975	44.733	44.733
23	19.349	19.349	20.337	20.337	22.985	22.985	33.950	33.950	38.436	38.436	41.163	41.163	43.890	43.890
25	18.782	18.782	20.609	20.609	22.377	22.377	32.746	32.746	37.655	37.655	40.351	40.351	43.047	43.047
27	18.216	18.216	20.881	20.881	21.769	21.769	31.542	31.542	36.873	36.873	39.539	39.539	42.204	42.204

Frost Region

**Remark:**

- AFR: Air flow rate (CFM)
- EWB: Entering Wet Bulb Temp. (°C)
- EDB: Entering Dry Bulb Temp. (°C)
- TC: Total Cooling / Heating Capacity (kW)
- SC: Sensible Cooling / Heating Capacity (kW)
- PI: Power Input (kW)

**Notes:**

- Ratings shown are gross capacities which do not include a deduction for indoor fan motor heat.
- shows nominal capacities.
- Direct interpolation is permissible. Do not extrapolate.
- Unit is able to operate at ambient from 19°C to 46°C DB (cooling) / -9°C to 18°C WB (heating) without pressure trip.

**Model: UATYP150AGXY1**

**Cooling Mode**

AFR (CFM)	EWB	EDB	Outdoor temperature																	
			19°C			25°C			30°C			35°C			40°C			46°C		
			TC	SC	PI	TC	SC	PI	TC	SC	PI	TC	SC	PI	TC	SC	PI	TC	SC	PI
5086	16°C	21°C	43.15	31.66	13.00	41.79	30.96	13.89	40.33	30.22	14.93	38.77	29.43	16.11	34.89	26.87	17.43	32.41	25.42	19.19
		24°C	43.32	37.71	13.01	41.96	36.92	13.91	40.50	36.09	14.94	38.96	35.21	16.13	35.08	32.23	17.45	32.58	30.63	19.21
		27°C	43.48	43.40	13.03	42.16	42.16	13.92	40.74	40.74	14.96	39.29	39.29	16.16	35.57	35.57	17.50	33.38	33.38	19.30
		30°C	45.21	45.21	13.15	44.07	44.07	14.08	42.84	42.84	15.15	41.53	41.53	16.37	37.73	37.73	17.73	35.47	35.47	19.55
	19°C	24°C	47.41	29.91	13.33	45.94	29.26	14.23	44.36	28.57	15.28	42.69	27.84	16.47	38.45	25.45	17.81	35.75	24.15	19.58
		27°C	47.54	34.94	13.33	46.05	34.22	14.24	44.48	33.47	15.30	42.82	32.67	16.49	38.59	29.92	17.82	35.91	28.46	19.60
		30°C	47.72	42.63	13.35	46.21	41.86	14.26	44.63	41.05	15.31	42.95	40.19	16.51	38.72	36.95	17.84	36.05	35.33	19.62
		33°C	48.00	48.00	13.37	46.63	46.63	14.29	45.27	45.27	15.37	43.91	43.91	16.60	39.93	39.93	17.97	37.60	37.60	19.80
	22°C	27°C	52.02	28.10	13.69	50.38	27.48	14.61	48.67	26.84	15.68	46.86	26.17	16.88	42.27	23.94	18.23	39.35	22.74	20.01
		30°C	52.09	34.73	13.69	50.45	34.04	14.62	48.75	33.32	15.69	46.95	32.55	16.89	42.36	29.84	18.24	39.46	28.43	20.02
		33°C	52.24	40.47	13.71	50.61	39.75	14.64	48.90	39.00	15.70	47.10	38.21	16.91	42.49	35.14	18.25	39.59	33.62	20.04
		36°C	52.39	46.08	13.72	50.76	45.36	14.65	49.03	44.59	15.72	47.24	43.80	16.92	42.66	40.35	18.27	39.94	38.45	20.09
5651	16°C	21°C	44.06	32.93	13.07	42.65	32.23	13.96	41.13	31.46	15.00	39.52	30.60	16.18	35.57	27.91	17.50	33.01	26.38	19.26
		24°C	44.29	39.26	13.09	42.88	38.46	13.98	41.37	37.61	15.02	39.77	36.71	16.20	35.79	33.62	17.52	33.20	31.97	19.28
		27°C	44.60	44.60	13.11	43.28	43.28	14.01	41.92	41.92	15.07	40.57	40.57	16.28	36.79	36.79	17.63	34.51	34.51	19.44
		30°C	46.91	46.91	13.29	45.70	45.70	14.21	44.41	44.41	15.29	43.03	43.03	16.51	39.06	39.06	17.88	36.71	36.71	19.70
	19°C	24°C	48.38	31.08	13.40	46.85	30.43	14.31	45.20	29.73	15.36	43.47	29.00	16.55	39.14	26.53	17.88	36.40	25.20	19.65
		27°C	48.56	36.39	13.41	47.03	35.65	14.33	45.40	34.88	15.38	43.67	34.06	16.57	39.34	31.21	17.90	36.58	29.72	19.68
		30°C	48.78	44.63	13.43	47.23	43.84	14.35	45.58	43.01	15.40	43.86	42.15	16.59	39.54	38.74	17.93	36.88	36.85	19.72
		33°C	49.55	49.55	13.49	48.28	48.28	14.43	46.94	46.94	15.52	45.52	45.52	16.75	41.38	41.38	18.13	38.95	38.95	19.97
	22°C	27°C	53.02	29.18	13.77	51.33	28.56	14.70	49.55	27.92	15.76	47.68	27.25	16.97	42.99	24.96	18.31	40.01	23.75	20.09
		30°C	53.15	36.24	13.78	51.46	35.52	14.71	49.69	34.77	15.78	47.83	33.98	16.98	43.13	31.17	18.32	40.17	29.71	20.11
		33°C	53.35	42.38	13.80	51.66	41.65	14.73	49.88	40.88	15.80	48.01	40.07	17.00	43.30	36.88	18.34	40.33	35.32	20.13
		36°C	53.54	48.46	13.81	51.84	47.71	14.74	50.09	46.86	15.82	48.36	45.87	17.03	43.83	42.40	18.40	41.22	40.43	20.24
6216	16°C	21°C	44.84	33.83	13.13	43.38	33.04	14.02	41.82	32.21	15.06	40.19	31.32	16.24	36.14	28.56	17.56	33.53	26.99	19.32
		24°C	45.13	40.31	13.15	43.66	39.50	14.05	42.11	38.64	15.09	40.46	37.74	16.27	36.38	34.57	17.59	33.76	32.91	19.35
		27°C	45.76	45.76	13.20	44.49	44.49	14.11	43.18	43.18	15.18	41.78	41.78	16.39	37.87	37.87	17.74	35.51	35.51	19.55
		30°C	48.42	48.42	13.40	47.14	47.14	14.34	45.78	45.78	15.41	44.34	44.34	16.64	40.24	40.24	18.00	37.79	37.79	19.82
	19°C	24°C	49.19	32.53	13.46	47.60	31.86	14.37	45.91	31.16	15.43	44.13	30.40	16.62	39.73	27.78	17.94	36.91	26.32	19.72
		27°C	49.44	38.08	13.48	47.85	37.33	14.40	46.16	36.52	15.45	44.38	35.69	16.64	39.96	32.72	17.97	37.13	31.18	19.75
		30°C	49.70	46.92	13.50	48.07	46.11	14.42	46.42	45.24	15.47	44.69	44.26	16.67	40.38	40.38	18.02	37.80	37.80	19.83
		33°C	51.15	51.15	13.62	49.83	49.83	14.57	48.43	48.43	15.66	46.95	46.95	16.89	42.65	42.65	18.27	40.12	40.12	20.11
	22°C	27°C	53.87	30.53	13.84	52.12	29.90	14.77	50.29	29.25	15.83	48.38	28.58	17.03	43.60	26.21	18.37	40.56	24.94	20.16
		30°C	54.05	37.96	13.85	52.31	37.22	14.78	50.50	36.44	15.85	48.59	35.63	17.06	43.79	32.69	18.40	40.76	31.19	20.18
		33°C	54.30	44.59	13.87	52.55	43.82	14.81	50.72	43.03	15.87	48.80	42.21	17.08	43.98	38.87	18.42	40.94	37.25	20.21
		36°C	54.57	51.06	13.90	52.94	50.12	14.84	51.27	49.01	15.93	49.61	47.74	17.16	45.10	43.89	18.55	42.49	41.68	20.40

**Model: UATYP150AGXY1**

**Heating Mode**

Indoor DB°C	Outdoor WB°C													
	-9		-6		-5		6		12		15		18	
	TC	SC	TC	SC	TC	SC	TC	SC	TC	SC	TC	SC	TC	SC
15	28.348	28.348	32.085	32.085	33.331	33.331	47.034	47.034	54.508	54.508	58.245	58.245	61.982	61.982
17	27.605	27.605	30.201	30.201	32.687	32.687	46.978	46.978	54.286	54.286	58.098	58.098	61.910	61.910
19	26.862	26.862	28.316	28.316	32.043	32.043	46.921	46.921	54.065	54.065	57.951	57.951	61.837	61.837
21	26.119	26.119	27.474	27.474	31.400	31.400	46.596	46.596	53.843	53.843	57.804	57.804	61.765	61.765
23	25.376	25.376	27.674	27.674	30.756	30.756	46.001	46.001	53.622	53.622	57.657	57.657	61.692	61.692
25	24.632	24.632	27.874	27.874	30.112	30.112	45.406	45.406	53.400	53.400	57.510	57.510	61.620	61.620
27	23.889	23.889	28.074	28.074	29.468	29.468	44.811	44.811	53.179	53.179	57.363	57.363	61.547	61.547
Frost Region														

**Remark:**

- AFR: Air flow rate (CFM)
- EWB: Entering Wet Bulb Temp. (°C)
- EDB: Entering Dry Bulb Temp. (°C)
- TC: Total Cooling / Heating Capacity (kW)
- SC: Sensible Cooling / Heating Capacity (kW)
- PI: Power Input (kW)

**Notes:**

1. Ratings shown are gross capacities which do not include a deduction for indoor fan motor heat.
2. ■ shows nominal capacities.
3. Direct interpolation is permissible. Do not extrapolate.
4. Unit is able to operate at ambient from 19°C to 46°C DB (cooling) / -9°C to 18°C WB (heating) without pressure trip.

**Model: UATYP200AGXY1**

**Cooling Mode**

AFR (CFM)	EWB	EDB	Outdoor temperature																	
			19°C			25°C			30°C			35°C			40°C			46°C		
			TC	SC	PI	TC	SC	PI	TC	SC	PI	TC	SC	PI	TC	SC	PI	TC	SC	PI
6039	16°C	21°C	55.02	37.78	16.68	53.28	36.94	17.82	51.43	36.06	19.15	49.44	35.12	20.67	44.49	32.06	22.36	41.33	30.33	24.62
		24°C	55.24	45.00	16.69	53.49	44.06	17.84	51.64	43.07	19.17	49.67	42.02	20.69	44.73	38.46	22.39	41.54	36.55	24.65
		27°C	55.44	51.79	16.71	53.75	50.83	17.86	51.94	49.78	19.20	50.10	48.49	20.73	45.35	44.16	22.45	42.56	41.48	24.77
		30°C	57.64	57.64	16.88	56.19	56.19	18.06	54.62	54.62	19.44	52.95	52.95	21.00	48.10	48.10	22.75	45.23	45.23	25.08
	19°C	24°C	60.45	35.69	17.10	58.57	34.91	18.26	56.56	34.09	19.61	54.43	33.22	21.14	49.03	30.37	22.85	45.58	28.81	25.12
		27°C	60.61	41.69	17.11	58.72	40.84	18.28	56.72	39.93	19.62	54.59	38.98	21.15	49.20	35.70	22.86	45.78	33.96	25.14
		30°C	60.84	50.87	17.13	58.92	49.95	18.30	56.90	48.98	19.65	54.76	47.96	21.18	49.37	44.09	22.89	45.96	42.16	25.17
		33°C	61.20	61.20	17.15	59.45	59.45	18.34	57.72	57.72	19.72	55.98	55.98	21.29	50.91	50.91	23.06	47.94	47.94	25.41
	22°C	27°C	66.33	33.53	17.56	64.23	32.79	18.75	62.05	32.03	20.12	59.75	31.23	21.66	53.89	28.57	23.39	50.17	27.14	25.68
		30°C	66.42	41.44	17.57	64.33	40.62	18.76	62.16	39.77	20.13	59.87	38.85	21.67	54.00	35.61	23.40	50.31	33.93	25.69
		33°C	66.61	48.29	17.59	64.53	47.43	18.78	62.35	46.53	20.15	60.05	45.59	21.69	54.18	41.93	23.42	50.48	40.12	25.72
		36°C	66.80	54.99	17.60	64.71	54.12	18.79	62.51	53.21	20.17	60.23	52.26	21.71	54.39	48.15	23.44	50.92	45.89	25.77
6710	16°C	21°C	56.18	39.30	16.77	54.38	38.46	17.91	52.44	37.54	19.24	50.39	36.52	20.76	45.35	33.31	22.45	42.09	31.48	24.71
		24°C	56.47	46.84	16.79	54.67	45.89	17.94	52.75	44.88	19.27	50.70	43.80	20.79	45.63	40.12	22.48	42.33	38.14	24.74
		27°C	56.86	54.31	16.82	55.18	53.14	17.98	53.45	51.76	19.33	51.73	50.15	20.88	46.91	45.70	22.62	44.01	43.00	24.94
		30°C	59.81	59.81	17.05	58.27	58.27	18.24	56.62	56.62	19.62	54.86	54.86	21.18	49.81	49.81	22.93	46.80	46.80	25.27
	19°C	24°C	61.68	37.09	17.19	59.73	36.31	18.36	57.64	35.48	19.71	55.42	34.60	21.24	49.91	31.66	22.94	46.40	30.07	25.22
		27°C	61.92	43.42	17.21	59.96	42.54	18.38	57.88	41.62	19.73	55.68	40.65	21.26	50.15	37.25	22.97	46.64	35.47	25.24
		30°C	62.20	53.25	17.23	60.21	52.32	18.41	58.11	51.33	19.76	55.92	50.30	21.29	50.42	46.23	23.00	47.02	43.97	25.30
		33°C	63.17	63.17	17.31	61.56	61.56	18.52	59.85	59.85	19.91	58.04	58.04	21.49	52.76	52.76	23.26	49.66	49.66	25.62
	22°C	27°C	67.61	34.82	17.66	65.44	34.08	18.86	63.18	33.32	20.22	60.79	32.51	21.77	54.81	29.78	23.49	51.02	28.34	25.78
		30°C	67.77	43.25	17.68	65.61	42.38	18.87	63.36	41.49	20.24	60.98	40.55	21.79	54.99	37.19	23.51	51.21	35.45	25.80
		33°C	68.03	50.58	17.70	65.87	49.70	18.90	63.60	48.78	20.27	61.22	47.81	21.81	55.21	44.01	23.54	51.42	42.15	25.83
		36°C	68.27	57.83	17.72	66.10	56.93	18.92	63.87	55.92	20.29	61.66	54.73	21.86	55.89	50.60	23.61	52.55	48.24	25.98
7381	16°C	21°C	57.18	40.37	16.84	55.30	39.43	17.99	53.32	38.43	19.32	51.24	37.38	20.84	46.08	34.08	22.53	42.75	32.21	24.79
		24°C	57.55	48.10	16.87	55.67	47.13	18.02	53.69	46.11	19.36	51.58	45.03	20.87	46.38	41.25	22.57	43.04	39.27	24.82
		27°C	58.35	56.07	16.93	56.73	55.14	18.11	55.06	54.07	19.48	53.27	52.84	21.03	48.28	48.04	22.77	45.27	45.26	25.09
		30°C	61.74	61.74	17.20	60.10	60.10	18.39	58.38	58.38	19.78	56.53	56.53	21.35	51.30	51.30	23.10	48.19	48.19	25.44
	19°C	24°C	62.71	38.82	17.27	60.69	38.02	18.44	58.54	37.18	19.79	56.26	36.27	21.32	50.66	33.14	23.02	47.07	31.41	25.30
		27°C	63.03	45.44	17.30	61.01	44.54	18.47	58.85	43.58	19.82	56.59	42.58	21.35	50.95	39.04	23.06	47.35	37.20	25.33
		30°C	63.36	55.99	17.33	61.29	55.02	18.50	59.19	53.98	19.85	56.98	52.82	21.39	51.48	48.29	23.12	48.20	45.60	25.44
		33°C	65.22	65.22	17.47	63.53	63.53	18.69	61.75	61.75	20.09	59.86	59.86	21.68	54.38	54.38	23.44	51.16	51.16	25.80
	22°C	27°C	68.68	36.43	17.75	66.46	35.68	18.95	64.12	34.90	20.31	61.68	34.11	21.86	55.59	31.28	23.58	51.72	29.76	25.86
		30°C	68.91	45.30	17.77	66.70	44.41	18.97	64.38	43.48	20.34	61.95	42.51	21.88	55.84	39.01	23.60	51.97	37.21	25.90
		33°C	69.24	53.20	17.80	67.00	52.30	19.00	64.67	51.35	20.37	62.22	50.37	21.92	56.07	46.38	23.64	52.20	44.45	25.93
		36°C	69.58	60.93	17.83	67.50	59.80	19.04	65.37	58.49	20.43	63.26	56.96	22.02	57.51	52.38	23.80	54.18	49.74	26.18

**Model: UATYP200AGXY1**

**Heating Mode**

Indoor DB°C	Outdoor WB°C													
	-9		-6		-5		6		12		15		18	
	TC	SC	TC	SC	TC	SC	TC	SC	TC	SC	TC	SC	TC	SC
15	40.751	40.751	46.123	46.123	47.913	47.913	67.611	67.611	78.355	78.355	83.727	83.727	89.099	89.099
17	39.682	39.682	42.914	42.914	46.757	46.757	67.530	67.530	76.826	76.826	82.132	82.132	87.438	87.438
19	38.614	38.614	39.705	39.705	45.601	45.601	67.449	67.449	75.296	75.296	80.537	80.537	85.777	85.777
21	37.546	37.546	38.275	38.275	44.445	44.445	66.240	66.240	73.767	73.767	78.941	78.941	84.116	84.116
23	36.477	36.477	38.622	38.622	43.289	43.289	63.902	63.902	72.238	72.238	77.346	77.346	82.455	82.455
25	35.409	35.409	38.970	38.970	42.133	42.133	61.563	61.563	70.708	70.708	75.751	75.751	80.794	80.794
27	34.341	34.341	39.318	39.318	40.977	40.977	59.225	59.225	69.179	69.179	74.156	74.156	79.132	79.132
Frost Region														

**Remark:**

- AFR: Air flow rate (CFM)
- EWB: Entering Wet Bulb Temp. (°C)
- EDB: Entering Dry Bulb Temp. (°C)
- TC: Total Cooling / Heating Capacity (kW)
- SC: Sensible Cooling / Heating Capacity (kW)
- PI: Power Input (kW)

**Notes:**

1. Ratings shown are gross capacities which do not include a deduction for indoor fan motor heat.
2. ■ shows nominal capacities.
3. Direct interpolation is permissible. Do not extrapolate.
4. Unit is able to operate at ambient from 19°C to 46°C DB (cooling) / -9°C to 18°C WB (heating) without pressure trip.

**Model: UATYP250AGXY1**

**Cooling Mode**

AFR (CFM)	EWB	EDB	Outdoor temperature																	
			19°C			25°C			30°C			35°C			40°C			46°C		
			TC	SC	PI	TC	SC	PI	TC	SC	PI	TC	SC	PI	TC	SC	PI	TC	SC	PI
7200	16°C	21°C	66.61	48.87	22.91	64.50	47.79	24.48	62.26	46.65	26.31	59.85	45.43	28.39	53.86	41.48	30.71	50.03	39.24	33.82
		24°C	66.87	58.21	22.93	64.76	56.99	24.51	62.52	55.71	26.33	60.13	54.36	28.42	54.15	49.75	30.75	50.29	47.28	33.85
		27°C	67.12	67.00	22.96	65.07	65.07	24.53	62.89	62.89	26.37	60.65	60.65	28.47	54.90	54.90	30.84	51.53	51.53	34.02
		30°C	69.78	69.78	23.18	68.02	68.02	24.81	66.13	66.13	26.70	64.10	64.10	28.84	58.23	58.23	31.24	54.76	54.76	34.45
	19°C	24°C	73.19	46.16	23.48	70.91	45.16	25.08	68.48	44.09	26.93	65.89	42.97	29.03	59.36	39.28	31.38	55.19	37.27	34.51
		27°C	73.38	53.93	23.50	71.09	52.83	25.10	68.67	51.66	26.95	66.09	50.42	29.06	59.57	46.18	31.40	55.42	43.93	34.53
		30°C	73.66	65.81	23.52	71.34	64.62	25.13	68.89	63.36	26.98	66.29	62.05	29.09	59.77	57.04	31.44	55.65	54.54	34.57
		33°C	74.09	74.09	23.56	71.97	71.97	25.19	69.87	69.87	27.08	67.78	67.78	29.24	61.63	61.63	31.67	58.05	58.05	34.90
	22°C	27°C	80.30	43.37	24.12	77.76	42.41	25.75	75.12	41.43	27.63	72.34	40.40	29.75	65.25	36.96	32.12	60.74	35.11	35.27
		30°C	80.41	53.61	24.13	77.88	52.55	25.77	75.26	51.44	27.64	72.48	50.25	29.77	65.38	46.07	32.13	60.91	43.89	35.29
		33°C	80.64	62.47	24.15	78.12	61.36	25.79	75.48	60.20	27.67	72.70	58.98	29.80	65.59	54.25	32.17	61.12	51.90	35.32
		36°C	80.87	71.14	24.17	78.35	70.01	25.81	75.68	68.83	27.70	72.91	67.61	29.82	65.85	62.28	32.20	61.65	59.36	35.40
8000	16°C	21°C	68.02	50.83	23.03	65.84	49.75	24.60	63.49	48.56	26.43	61.01	47.24	28.51	54.91	43.08	30.84	50.96	40.72	33.94
		24°C	68.37	60.60	23.06	66.19	59.36	24.64	63.87	58.05	26.47	61.38	56.66	28.55	55.24	51.89	30.88	51.25	49.34	33.98
		27°C	68.84	68.84	23.10	66.80	66.80	24.69	64.71	64.71	26.55	62.62	62.62	28.68	56.79	56.79	31.07	53.28	53.28	34.25
		30°C	72.41	72.41	23.41	70.55	70.55	25.05	68.55	68.55	26.94	66.42	66.42	29.09	60.30	60.30	31.50	56.66	56.66	34.71
	19°C	24°C	74.68	47.98	23.61	72.32	46.97	25.22	69.78	45.89	27.07	67.10	44.76	29.17	60.42	40.96	31.51	56.18	38.90	34.63
		27°C	74.96	56.17	23.64	72.59	55.04	25.24	70.07	53.84	27.10	67.41	52.58	29.20	60.72	48.18	31.55	56.47	45.88	34.67
		30°C	75.30	68.89	23.67	72.90	67.67	25.28	70.35	66.39	27.14	67.71	65.07	29.24	61.04	59.81	31.59	56.92	56.88	34.74
		33°C	76.48	76.48	23.77	74.53	74.53	25.43	72.46	72.46	27.35	70.27	70.27	29.52	63.87	63.87	31.95	60.12	60.12	35.18
	22°C	27°C	81.85	45.05	24.26	79.23	44.09	25.90	76.49	43.10	27.78	73.60	42.06	29.90	66.35	38.52	32.26	61.76	36.66	35.41
		30°C	82.04	55.95	24.28	79.43	54.83	25.92	76.71	53.67	27.80	73.83	52.45	29.92	66.57	48.11	32.29	62.00	45.86	35.44
		33°C	82.36	65.43	24.31	79.75	64.29	25.95	77.00	63.10	27.84	74.11	61.85	29.96	66.84	56.93	32.33	62.25	54.52	35.48
		36°C	82.65	74.80	24.34	80.02	73.65	25.98	77.32	72.33	27.87	74.65	70.80	30.02	67.66	65.45	32.43	63.62	62.41	35.68
8800	16°C	21°C	69.22	52.22	23.13	66.96	51.01	24.71	64.56	49.72	26.54	62.03	48.35	28.62	55.79	44.09	30.94	51.75	41.67	34.05
		24°C	69.67	62.23	23.17	67.40	60.97	24.75	65.00	59.65	26.58	62.45	58.25	28.67	56.16	53.36	30.99	52.11	50.80	34.10
		27°C	70.64	70.64	23.25	68.68	68.68	24.87	66.66	66.66	26.75	64.49	64.49	28.88	58.46	58.46	31.27	54.81	54.81	34.45
		30°C	74.74	74.74	23.62	72.77	72.77	25.26	70.67	70.67	27.16	68.44	68.44	29.32	62.11	62.11	31.73	58.34	58.34	34.94
	19°C	24°C	75.93	50.21	23.73	73.48	49.19	25.33	70.87	48.09	27.18	68.12	46.92	29.28	61.33	42.88	31.62	56.98	40.63	34.75
		27°C	76.31	58.78	23.76	73.87	57.62	25.37	71.25	56.38	27.22	68.51	55.09	29.32	61.68	50.51	31.67	57.32	48.12	34.80
		30°C	76.71	72.43	23.80	74.21	71.17	25.41	71.66	69.83	27.27	68.98	68.33	29.38	62.33	62.33	31.75	58.35	58.35	34.94
		33°C	78.96	78.96	24.00	76.92	76.92	25.67	74.76	74.76	27.59	72.47	72.47	29.77	65.84	65.84	32.20	61.94	61.94	35.44
	22°C	27°C	83.15	47.12	24.38	80.46	46.16	26.02	77.63	45.15	27.90	74.68	44.12	30.02	67.30	40.46	32.38	62.61	38.50	35.52
		30°C	83.43	58.60	24.41	80.75	57.45	26.05	77.95	56.25	27.93	75.00	54.99	30.06	67.60	50.46	32.42	62.92	48.14	35.57
		33°C	83.82	68.82	24.45	81.12	67.65	26.09	78.29	66.43	27.97	75.33	65.15	30.10	67.89	59.99	32.47	63.20	57.50	35.62
		36°C	84.24	78.82	24.49	81.72	77.36	26.15	79.15	75.66	28.07	76.59	73.69	30.25	69.62	67.75	32.69	65.59	64.34	35.95

**Model: UATYP250AGXY1**

**Heating Mode**

Indoor DB°C	Outdoor WB°C													
	-9		-6		-5		6		12		15		18	
	TC	SC	TC	SC	TC	SC	TC	SC	TC	SC	TC	SC	TC	SC
15	45.180	45.180	51.136	51.136	53.121	53.121	74.960	74.960	86.872	86.872	92.828	92.828	98.784	98.784
17	43.996	43.996	48.325	48.325	52.022	52.022	74.870	74.870	86.132	86.132	92.151	92.151	98.171	98.171
19	42.811	42.811	45.514	45.514	50.922	50.922	74.781	74.781	85.392	85.392	91.475	91.475	97.558	97.558
21	41.627	41.627	44.152	44.152	49.822	49.822	74.025	74.025	84.652	84.652	90.798	90.798	96.945	96.945
23	40.442	40.442	44.238	44.238	48.722	48.722	72.603	72.603	83.912	83.912	90.122	90.122	96.332	96.332
25	39.258	39.258	44.324	44.324	47.623	47.623	71.180	71.180	83.172	83.172	89.445	89.445	95.719	95.719
27	38.074	38.074	44.410	44.410	46.523	46.523	69.758	69.758	82.432	82.432	88.769	88.769	95.106	95.106

Frost Region

**Remark:**

- AFR: Air flow rate (CFM)
- EWB: Entering Wet Bulb Temp. (°C)
- EDB: Entering Dry Bulb Temp. (°C)
- TC: Total Cooling / Heating Capacity (kW)
- SC: Sensible Cooling / Heating Capacity (kW)
- PI: Power Input (kW)

**Notes:**

- Ratings shown are gross capacities which do not include a deduction for indoor fan motor heat.
- shows nominal capacities.
- Direct interpolation is permissible. Do not extrapolate.
- Unit is able to operate at ambient from 19°C to 46°C DB (cooling) / -9°C to 18°C WB (heating) without pressure trip.

**Model: UATYP300AGXY1**

**Cooling Mode**

AFR (CFM)	EWB	EDB	Outdoor temperature																	
			19°C			25°C			30°C			35°C			40°C			46°C		
			TC	SC	PI	TC	SC	PI	TC	SC	PI	TC	SC	PI	TC	SC	PI	TC	SC	PI
8640	16°C	21°C	81.96	60.12	29.93	79.37	58.80	31.99	76.60	57.39	34.38	73.64	55.90	37.10	66.27	51.03	40.14	61.56	48.28	44.19
		24°C	82.28	71.62	29.96	79.68	70.12	32.03	76.93	68.55	34.42	73.99	66.88	37.14	66.62	61.21	40.18	61.87	58.17	44.24
		27°C	82.58	82.43	30.00	80.06	80.06	32.06	77.38	77.38	34.46	74.63	74.63	37.21	67.55	67.55	40.30	63.40	63.40	44.46
		30°C	85.86	85.86	30.29	83.70	83.70	32.42	81.36	81.36	34.89	78.87	78.87	37.69	71.65	71.65	40.83	67.37	67.37	45.02
	19°C	24°C	90.05	56.80	30.69	87.25	55.56	32.78	84.25	54.25	35.20	81.07	52.87	37.94	73.03	48.33	41.01	67.90	45.86	45.09
		27°C	90.28	66.35	30.71	87.47	65.00	32.80	84.49	63.56	35.22	81.32	62.04	37.97	73.29	56.82	41.04	68.19	54.05	45.13
		30°C	90.63	80.97	30.74	87.77	79.50	32.84	84.76	77.96	35.26	81.56	76.34	38.01	73.55	70.18	41.08	68.47	67.10	45.18
		33°C	91.16	91.16	30.79	88.55	88.55	32.91	85.97	85.97	35.39	83.39	83.39	38.22	75.83	75.83	41.38	71.42	71.42	45.61
	22°C	27°C	98.80	53.36	31.52	95.68	52.19	33.66	92.43	50.97	36.11	89.01	49.70	38.88	80.28	45.47	41.97	74.74	43.19	46.09
		30°C	98.94	65.96	31.54	95.83	64.66	33.67	92.60	63.29	36.13	89.18	61.83	38.90	80.44	56.68	41.99	74.94	54.00	46.11
		33°C	99.22	76.87	31.56	96.12	75.49	33.70	92.87	74.06	36.16	89.45	72.57	38.94	80.70	66.74	42.04	75.20	63.86	46.16
		36°C	99.50	87.53	31.59	96.40	86.14	33.74	93.11	84.68	36.20	89.71	83.18	38.97	81.02	76.63	42.08	75.86	73.03	46.26
9600	16°C	21°C	83.69	62.54	30.09	81.01	61.21	32.15	78.12	59.75	34.54	75.06	58.12	37.26	67.56	53.01	40.30	62.70	50.10	44.35
		24°C	84.12	74.56	30.14	81.44	73.04	32.20	78.58	71.43	34.59	75.52	69.72	37.31	67.97	63.85	40.35	63.06	60.71	44.41
		27°C	84.71	84.71	30.19	82.19	82.19	32.27	79.62	79.62	34.70	77.05	77.05	37.48	69.88	69.88	40.60	65.55	65.55	44.76
		30°C	89.10	89.10	30.60	86.80	86.80	32.74	84.34	84.34	35.21	81.72	81.72	38.02	74.19	74.19	41.17	69.72	69.72	45.36
	19°C	24°C	91.88	59.04	30.86	88.98	57.79	32.95	85.85	56.47	35.38	82.55	55.08	38.12	74.34	50.39	41.18	69.12	47.86	45.26
		27°C	92.23	69.10	30.89	89.32	67.71	32.99	86.22	66.24	35.41	82.94	64.69	38.16	74.71	59.28	41.23	69.48	56.45	45.31
		30°C	92.65	84.76	30.93	89.69	83.27	33.04	86.56	81.69	35.46	83.30	80.06	38.21	75.10	73.58	41.28	70.04	69.99	45.41
		33°C	94.10	94.10	31.07	91.70	91.70	33.24	89.16	89.16	35.74	86.46	86.46	38.58	78.59	78.59	41.75	73.97	73.97	45.98
	22°C	27°C	100.70	55.42	31.71	97.48	54.25	33.85	94.12	53.03	36.30	90.56	51.75	39.07	81.64	47.40	42.16	75.99	45.10	46.27
		30°C	100.95	68.83	31.73	97.73	67.46	33.87	94.38	66.04	36.33	90.83	64.54	39.10	81.91	59.19	42.19	76.29	56.42	46.31
		33°C	101.33	80.50	31.77	98.12	79.10	33.92	94.74	77.63	36.38	91.19	76.10	39.15	82.24	70.05	42.25	76.59	67.08	46.37
		36°C	101.69	92.04	31.81	98.46	90.62	33.96	95.14	89.00	36.42	91.84	87.11	39.23	83.25	80.53	42.38	78.28	76.78	46.62
10560	16°C	21°C	85.17	64.25	30.23	82.38	62.76	32.29	79.43	61.17	34.68	76.32	59.49	37.40	68.64	54.24	40.44	63.67	51.27	44.50
		24°C	85.72	76.56	30.28	82.93	75.02	32.35	79.98	73.40	34.74	76.84	71.67	37.46	69.09	65.66	40.50	64.11	62.50	44.56
		27°C	86.92	86.92	30.39	84.50	84.50	32.50	82.01	82.01	34.96	79.35	79.35	37.75	71.92	71.92	40.87	67.43	67.43	45.03
		30°C	91.96	91.96	30.87	89.53	89.53	33.02	86.96	86.96	35.50	84.21	84.21	38.31	76.42	76.42	41.46	71.78	71.78	45.66
	19°C	24°C	93.42	61.78	31.01	90.41	60.52	33.10	87.20	59.17	35.52	83.81	57.73	38.27	75.46	52.75	41.32	70.11	49.98	45.41
		27°C	93.89	72.32	31.05	90.89	70.89	33.15	87.67	69.37	35.58	84.29	67.78	38.32	75.89	62.14	41.39	70.53	59.21	45.47
		30°C	94.38	89.12	31.10	91.30	87.56	33.21	88.16	85.92	35.64	84.87	84.07	38.39	76.69	76.69	41.50	71.79	71.79	45.66
		33°C	97.15	97.15	31.36	94.64	94.64	33.55	91.99	91.99	36.06	89.16	89.16	38.91	81.01	81.01	42.08	76.20	76.20	46.31
	22°C	27°C	102.31	57.98	31.86	98.99	56.79	34.01	95.51	55.55	36.46	91.88	54.29	39.23	82.81	49.78	42.32	77.04	47.37	46.42
		30°C	102.65	72.10	31.90	99.35	70.69	34.05	95.90	69.21	36.50	92.28	67.66	39.28	83.17	62.09	42.37	77.42	59.23	46.48
		33°C	103.14	84.68	31.95	99.81	83.23	34.10	96.33	81.73	36.56	92.68	80.16	39.34	83.53	73.82	42.43	77.76	70.75	46.54
		36°C	103.65	96.98	32.00	100.54	95.18	34.17	97.38	93.09	36.68	94.23	90.66	39.53	85.66	83.36	42.72	80.70	79.16	46.99

**Model: UATYP300AGXY1**

**Heating Mode**

Indoor DB°C	Outdoor WB°C													
	-9		-6		-5		6		12		15		18	
	TC	SC	TC	SC	TC	SC	TC	SC	TC	SC	TC	SC	TC	SC
15	55.811	55.811	63.168	63.168	65.620	65.620	92.597	92.597	107.312	107.312	114.670	114.670	122.027	122.027
17	54.348	54.348	69.964	69.964	64.259	64.259	92.487	92.487	106.385	106.385	113.819	113.819	121.252	121.252
19	52.884	52.884	76.760	76.760	62.898	62.898	92.376	92.376	105.457	105.457	112.968	112.968	120.478	120.478
21	51.421	51.421	76.543	76.543	61.537	61.537	91.435	91.435	104.530	104.530	112.117	112.117	119.703	119.703
23	49.958	49.958	69.311	69.311	60.176	60.176	89.661	89.661	103.602	103.602	111.265	111.265	118.929	118.929
25	48.495	48.495	62.080	62.080	58.815	58.815	87.888	87.888	102.675	102.675	110.414	110.414	118.154	118.154
27	47.032	47.032	54.849	54.849	57.454	57.454	86.114	86.114	101.747	101.747	109.563	109.563	117.380	117.380

**Frost Region**

**Remark:**

- AFR: Air flow rate (CFM)
- EWB: Entering Wet Bulb Temp. (°C)
- EDB: Entering Dry Bulb Temp. (°C)
- TC: Total Cooling / Heating Capacity (kW)
- SC: Sensible Cooling / Heating Capacity (kW)
- PI: Power Input (kW)

**Notes:**

1. Ratings shown are gross capacities which do not include a deduction for indoor fan motor heat.
2. ■ shows nominal capacities.
3. Direct interpolation is permissible. Do not extrapolate.
4. Unit is able to operate at ambient from 19°C to 46°C DB (cooling) / -9°C to 18°C WB (heating) without pressure trip.

**Model: UATYP360AGXY1**

**Cooling Mode**

AFR (CFM)	EWB	EDB	Outdoor temperature																							
			19°C				25°C				30°C				35°C				40°C				46°C			
			TC	SC	PI	TC	SC	PI	TC	SC	PI	TC	SC	PI	TC	SC	PI	TC	SC	PI	TC	SC	PI			
9900	16°C	21°C	99.91	78.93	33.86	96.75	77.19	36.19	93.39	75.35	38.89	89.78	73.39	41.97	80.79	67.00	45.41	75.04	63.38	50.00						
		24°C	100.30	94.02	33.90	97.14	92.06	36.23	93.78	90.00	38.93	90.20	87.80	42.01	81.22	80.36	45.46	75.43	75.43	50.05						
		27°C	100.67	100.67	33.94	97.60	97.60	36.27	94.33	94.33	38.98	90.98	90.98	42.10	82.35	82.35	45.60	77.29	77.29	50.29						
		30°C	104.67	104.67	34.27	102.03	102.03	36.68	99.19	99.19	39.47	96.15	96.15	42.64	87.35	87.35	46.19	82.13	82.13	50.93						
	19°C	24°C	109.78	74.57	34.72	106.37	72.95	37.08	102.71	71.22	39.82	98.83	69.41	42.92	89.03	63.45	46.39	82.78	60.21	51.01						
		27°C	110.06	87.11	34.74	106.63	85.33	37.11	102.99	83.44	39.85	99.14	81.45	42.96	89.35	74.60	46.43	83.13	70.96	51.05						
		30°C	110.48	106.30	34.78	107.00	104.38	37.15	103.33	102.35	39.89	99.43	99.43	43.00	89.66	89.66	46.48	83.46	83.46	51.11						
		33°C	111.12	111.12	34.83	107.95	107.95	37.24	104.81	104.81	40.04	101.66	101.66	43.24	92.45	92.45	46.82	87.06	87.06	51.59						
	22°C	27°C	120.45	70.06	35.66	116.64	68.51	38.08	112.68	66.92	40.85	108.50	65.25	43.99	97.86	59.70	47.49	91.11	56.71	52.14						
		30°C	120.61	86.60	35.68	116.82	84.88	38.09	112.88	83.09	40.87	108.71	81.17	44.01	98.07	74.41	47.51	91.36	70.89	52.17						
		33°C	120.95	100.91	35.71	117.17	99.11	38.13	113.22	97.23	40.91	109.04	95.27	44.05	98.38	87.62	47.56	91.67	83.84	52.22						
		36°C	121.29	114.91	35.74	117.52	113.09	38.16	113.51	111.18	40.95	109.36	109.21	44.09	98.77	98.77	47.60	92.47	92.47	52.33						
11000	16°C	21°C	102.02	82.11	34.05	98.75	80.36	36.37	95.23	78.44	39.08	91.51	76.31	42.15	82.35	69.59	45.59	76.43	65.78	50.18						
		24°C	102.55	97.88	34.09	99.28	95.89	36.43	95.79	93.78	39.13	92.07	91.53	42.21	82.86	82.86	45.65	76.88	76.88	50.24						
		27°C	103.26	103.26	34.15	100.20	100.20	36.51	97.07	97.07	39.26	93.93	93.93	42.41	85.19	85.19	45.93	79.91	79.91	50.64						
		30°C	108.62	108.62	34.61	105.82	105.82	37.03	102.82	102.82	39.83	99.62	99.62	43.01	90.45	90.45	46.57	84.99	84.99	51.31						
	19°C	24°C	112.01	77.51	34.91	108.47	75.88	37.28	104.66	74.13	40.02	100.64	72.31	43.12	90.63	66.16	46.59	84.27	62.83	51.20						
		27°C	112.44	90.72	34.95	108.89	88.90	37.32	105.10	86.96	40.06	101.11	84.93	43.17	91.08	77.83	46.64	84.70	74.11	51.26						
		30°C	112.95	111.28	35.00	109.34	109.31	37.37	105.52	105.52	40.12	101.55	101.55	43.23	91.55	91.55	46.70	85.38	85.38	51.37						
		33°C	114.72	114.72	35.15	111.79	111.79	37.60	108.69	108.69	40.44	105.40	105.40	43.65	95.80	95.80	47.23	90.17	90.17	52.02						
	22°C	27°C	122.77	72.76	35.87	118.83	71.22	38.29	114.73	69.62	41.07	110.40	67.94	44.20	99.53	62.22	47.69	92.64	59.21	52.35						
		30°C	123.06	90.37	35.90	119.14	88.56	38.32	115.05	86.69	41.10	110.73	84.73	44.24	99.86	77.71	47.73	93.00	74.08	52.39						
		33°C	123.53	105.68	35.94	119.62	103.85	38.37	115.50	101.92	41.15	111.16	99.91	44.30	100.25	91.96	47.79	93.37	88.07	52.45						
		36°C	123.96	120.83	35.98	120.03	118.96	38.41	115.98	115.98	41.21	111.96	111.96	44.38	101.49	101.49	47.95	95.43	95.43	52.74						
12100	16°C	21°C	103.83	84.35	34.20	100.43	82.39	36.53	96.83	80.31	39.24	93.04	78.11	42.31	83.68	71.21	45.75	77.62	67.31	50.34						
		24°C	104.50	100.52	34.26	101.10	98.49	36.60	97.50	96.36	39.30	93.67	93.67	42.38	84.23	84.23	45.82	78.16	78.16	50.41						
		27°C	105.96	105.96	34.38	103.01	103.01	36.77	99.98	99.98	39.55	96.73	96.73	42.70	87.68	87.68	46.23	82.21	82.21	50.94						
		30°C	112.11	112.11	34.92	109.14	109.14	37.35	106.01	106.01	40.16	102.66	102.66	43.34	93.16	93.16	46.90	87.50	87.50	51.65						
	19°C	24°C	113.88	81.11	35.08	110.21	79.45	37.45	106.30	77.69	40.19	102.17	75.79	43.29	91.99	69.26	46.75	85.47	65.62	51.37						
		27°C	114.46	94.95	35.13	110.80	93.07	37.51	106.87	91.07	40.25	102.76	88.98	43.35	92.52	81.58	46.82	85.98	77.74	51.44						
		30°C	115.06	115.06	35.18	111.30	111.30	37.57	107.48	107.48	40.31	103.46	103.46	43.43	93.49	93.49	46.94	87.52	87.52	51.66						
		33°C	118.44	118.44	35.48	115.37	115.37	37.95	112.14	112.14	40.80	108.70	108.70	44.01	98.75	98.75	47.60	92.90	92.90	52.39						
	22°C	27°C	124.72	76.11	36.05	120.68	74.56	38.47	116.44	72.93	41.25	112.01	71.27	44.38	100.95	65.36	47.87	93.91	62.19	52.52						
		30°C	125.13	94.66	36.09	121.11	92.80	38.52	116.91	90.86	41.30	112.49	88.83	44.44	101.40	81.51	47.93	94.38	77.76	52.58						
		33°C	125.73	111.17	36.14	121.67	109.27	38.57	117.43	107.30	41.36	112.98	105.24	44.50	101.83	96.91	48.00	94.79	92.88	52.66						
		36°C	126.36	126.36	36.20	122.57	122.57	38.66	118.71	118.71	41.49	114.87	114.87	44.72	104.43	104.43	48.33	98.38	98.38	53.16						

**Model: UATYP360AGXY1**

**Heating Mode**

Indoor DB°C	Outdoor WB°C													
	-9		-6		-5		6		12		15		18	
	TC	SC	TC	SC	TC	SC	TC	SC	TC	SC	TC	SC	TC	SC
15	61.835	61.835	69.986	69.986	72.703	72.703	102.592	102.592	118.895	118.895	127.047	127.047	135.198	135.198
17	60.214	60.214	71.652	71.652	71.791	71.791	102.470	102.470	120.993	120.993	129.676	129.676	138.359	138.359
19	58.593	58.593	73.317	73.317	70.878	70.878	102.347	102.347	123.091	123.091	132.305	132.305	141.519	141.519
21	56.972	56.972	72.621	72.621	69.965	69.965	103.217	103.217	125.189	125.189	134.935	134.935	144.680	144.680
23	55.351	55.351	69.563	69.563	69.053	69.053	105.080	105.080	127.287	127.287	137.564	137.564	147.841	147.841
25	53.730	53.730	66.506	66.506	68.140	68.140	106.942	106.942	129.385	129.385	140.193	140.193	151.001	151.001
27	52.109	52.109	63.448	63.448	67.228	67.228	108.805	108.805	131.483	131.483	142.823	142.823	154.162	154.162

Frost Region

**Remark:**

- AFR: Air flow rate (CFM)
- EWB: Entering Wet Bulb Temp. (°C)
- EDB: Entering Dry Bulb Temp. (°C)
- TC: Total Cooling / Heating Capacity (kW)
- SC: Sensible Cooling / Heating Capacity (kW)
- PI: Power Input (kW)

**Notes:**

- Ratings shown are gross capacities which do not include a deduction for indoor fan motor heat.
- shows nominal capacities.
- Direct interpolation is permissible. Do not extrapolate.
- Unit is able to operate at ambient from 19°C to 46°C DB (cooling) / -9°C to 18°C WB (heating) without pressure trip.

**Model: UATYP420AGXY1**

**Cooling Mode**

AFR (CFM)	EWB	EDB	Outdoor temperature																	
			19°C			25°C			30°C			35°C			40°C			46°C		
			TC	SC	PI	TC	SC	PI	TC	SC	PI	TC	SC	PI	TC	SC	PI	TC	SC	PI
11250	16°C	21°C	108.31	85.57	37.81	104.89	83.68	40.41	101.24	81.68	43.42	97.32	79.56	46.86	87.58	72.63	50.70	81.35	68.71	55.82
		24°C	108.74	101.92	37.85	105.31	99.80	40.45	101.66	97.56	43.47	97.78	95.19	46.91	88.04	87.12	50.75	81.77	81.77	55.88
		27°C	109.14	109.14	37.89	105.81	105.81	40.50	102.26	102.26	43.53	98.63	98.63	47.00	89.28	89.28	50.91	83.78	83.78	56.15
		30°C	113.47	113.47	38.26	110.61	110.61	40.95	107.53	107.53	44.07	104.24	104.24	47.61	94.69	94.69	51.58	89.03	89.03	56.87
	19°C	24°C	119.01	80.84	38.76	115.31	79.08	41.40	111.34	77.21	44.46	107.14	75.25	47.92	96.52	68.78	51.79	89.74	65.27	56.96
		27°C	119.31	94.43	38.79	115.59	92.50	41.43	111.65	90.46	44.49	107.47	88.30	47.96	96.86	80.87	51.84	90.12	76.93	57.00
		30°C	119.77	115.24	38.83	116.00	113.15	41.48	112.01	110.96	44.54	107.79	107.79	48.02	97.19	97.19	51.89	90.48	90.48	57.06
		33°C	120.47	120.47	38.89	117.03	117.03	41.57	113.62	113.62	44.70	110.21	110.21	48.27	100.22	100.22	52.27	94.38	94.38	57.61
	22°C	27°C	130.57	75.95	39.81	126.44	74.27	42.51	122.15	72.54	45.61	117.63	70.74	49.11	106.09	64.72	53.02	98.77	61.47	58.22
		30°C	130.75	93.88	39.83	126.64	92.02	42.53	122.37	90.08	45.63	117.85	88.00	49.14	106.31	80.67	53.04	99.04	76.85	58.25
		33°C	131.12	109.40	39.87	127.02	107.44	42.57	122.73	105.41	45.68	118.21	103.28	49.19	106.65	94.99	53.10	99.38	90.88	58.30
		36°C	131.49	124.57	39.91	127.40	122.60	42.61	123.05	120.52	45.72	118.56	118.39	49.23	107.07	107.07	53.15	100.25	100.25	58.43
12500	16°C	21°C	110.60	89.01	38.01	107.05	87.12	40.61	103.23	85.03	43.63	99.20	82.72	47.07	89.28	75.44	50.90	82.86	71.31	56.02
		24°C	111.17	106.11	38.07	107.63	103.95	40.67	103.85	101.66	43.69	99.81	99.22	47.13	89.82	89.82	50.97	83.34	83.34	56.10
		27°C	111.94	111.94	38.13	108.62	108.62	40.76	105.23	105.23	43.83	101.83	101.83	47.35	92.35	92.35	51.28	86.63	86.63	56.54
		30°C	117.75	117.75	38.65	114.72	114.72	41.35	111.46	111.46	44.48	107.99	107.99	48.03	98.05	98.05	52.00	92.14	92.14	57.29
	19°C	24°C	121.43	84.02	38.98	117.59	82.25	41.62	113.46	80.37	44.68	109.10	78.38	48.14	98.24	71.72	52.02	91.35	68.11	57.17
		27°C	121.89	98.35	39.02	118.04	96.37	41.67	113.94	94.28	44.73	109.61	92.07	48.20	98.73	84.37	52.08	91.82	80.34	57.23
		30°C	122.44	120.63	39.07	118.53	118.50	41.73	114.40	114.40	44.79	110.09	110.09	48.26	99.25	99.25	52.14	92.56	92.56	57.35
		33°C	124.36	124.36	39.24	121.18	121.18	41.98	117.83	117.83	45.15	114.26	114.26	48.73	103.86	103.86	52.74	97.75	97.75	58.08
	22°C	27°C	133.09	78.88	40.05	128.82	77.20	42.75	124.38	75.47	45.85	119.68	73.65	49.35	107.89	67.46	53.25	100.43	64.19	58.44
		30°C	133.41	97.97	40.08	129.16	96.01	42.79	124.73	93.98	45.89	120.04	91.85	49.39	108.25	84.24	53.30	100.82	80.30	58.50
		33°C	133.92	114.57	40.13	129.68	112.58	42.84	125.21	110.49	45.95	120.51	108.31	49.46	108.68	99.69	53.36	101.22	95.47	58.57
		36°C	134.38	130.99	40.18	130.12	128.97	42.89	125.73	125.73	46.01	121.38	121.38	49.55	110.02	110.02	53.54	103.45	103.45	58.89
13750	16°C	21°C	112.55	91.44	38.18	108.87	89.32	40.79	104.97	87.06	43.81	100.87	84.67	47.24	90.72	77.20	51.08	84.15	72.97	56.21
		24°C	113.28	108.97	38.25	109.60	106.77	40.86	105.70	104.46	43.88	101.55	101.55	47.32	91.31	91.31	51.16	84.73	84.73	56.28
		27°C	114.87	114.87	38.38	111.67	111.67	41.06	108.38	108.38	44.15	104.86	104.86	47.68	95.05	95.05	51.62	89.12	89.12	56.87
		30°C	121.53	121.53	38.99	118.32	118.32	41.70	114.92	114.92	44.84	111.29	111.29	48.39	100.99	100.99	52.37	94.86	94.86	57.67
	19°C	24°C	123.46	87.93	39.16	119.48	86.13	41.81	115.24	84.22	44.87	110.76	82.16	48.34	99.72	75.08	52.19	92.65	71.14	57.35
		27°C	124.08	102.93	39.22	120.11	100.89	41.88	115.86	98.72	44.94	111.40	96.46	48.41	100.30	88.44	52.28	93.20	84.27	57.44
		30°C	124.73	124.73	39.28	120.66	120.66	41.94	116.51	116.51	45.01	112.16	112.16	48.49	101.35	101.35	52.41	94.88	94.88	57.68
		33°C	128.39	128.39	39.62	125.07	125.07	42.37	121.57	121.57	45.55	117.84	117.84	49.14	107.06	107.06	53.15	100.71	100.71	58.49
	22°C	27°C	135.20	82.51	40.25	130.83	80.82	42.95	126.23	79.06	46.05	121.43	77.26	49.55	109.43	70.85	53.45	101.81	67.42	58.64
		30°C	135.65	102.62	40.29	131.29	100.60	43.00	126.74	98.50	46.11	121.95	96.30	49.61	109.92	88.37	53.51	102.32	84.30	58.71
		33°C	136.30	120.52	40.36	131.90	118.46	43.07	127.31	116.32	46.18	122.48	114.09	49.69	110.39	105.06	53.59	102.76	100.69	58.79
		36°C	136.98	136.98	40.42	132.87	132.87	43.16	128.69	128.69	46.33	124.53	124.53	49.93	113.21	113.21	53.96	106.65	106.65	59.35

**Model: UATYP420AGXY1**

**Heating Mode**

Indoor DB°C	Outdoor WB°C													
	-9		-6		-5		6		12		15		18	
	TC	SC	TC	SC	TC	SC	TC	SC	TC	SC	TC	SC	TC	SC
15	76.363	76.363	86.430	86.430	89.785	89.785	126.697	126.697	146.830	146.830	156.897	156.897	166.964	166.964
17	74.361	74.361	85.269	85.269	87.923	87.923	126.546	126.546	145.562	145.562	155.733	155.733	165.905	165.905
19	72.359	72.359	84.109	84.109	86.061	86.061	126.394	126.394	144.293	144.293	154.570	154.570	164.846	164.846
21	70.357	70.357	82.317	82.317	84.199	84.199	125.106	125.106	143.025	143.025	153.406	153.406	163.787	163.787
23	68.356	68.356	79.894	79.894	82.337	82.337	122.680	122.680	141.756	141.756	152.242	152.242	162.728	162.728
25	66.354	66.354	77.470	77.470	80.474	80.474	120.254	120.254	140.488	140.488	151.078	151.078	161.669	161.669
27	64.352	64.352	75.047	75.047	78.612	78.612	117.828	117.828	139.219	139.219	149.914	149.914	160.610	160.610

Frost Region

**Remark:**

- AFR: Air flow rate (CFM)
- EWB: Entering Wet Bulb Temp. (°C)
- EDB: Entering Dry Bulb Temp. (°C)
- TC: Total Cooling Capacity (kW)
- SC: Sensible Cooling Capacity (kW)
- PI: Power Input (kW)

**Notes:**

- Ratings shown are gross capacities which do not include a deduction for indoor fan motor heat.
- shows nominal capacities.
- Direct interpolation is permissible. Do not extrapolate.
- Unit is able to operate at ambient from 19°C to 46°C DB (cooling) / -9°C to 18°C WB (heating) without pressure trip.

# Outline & Dimension

## Model: UAT(Y)P60A

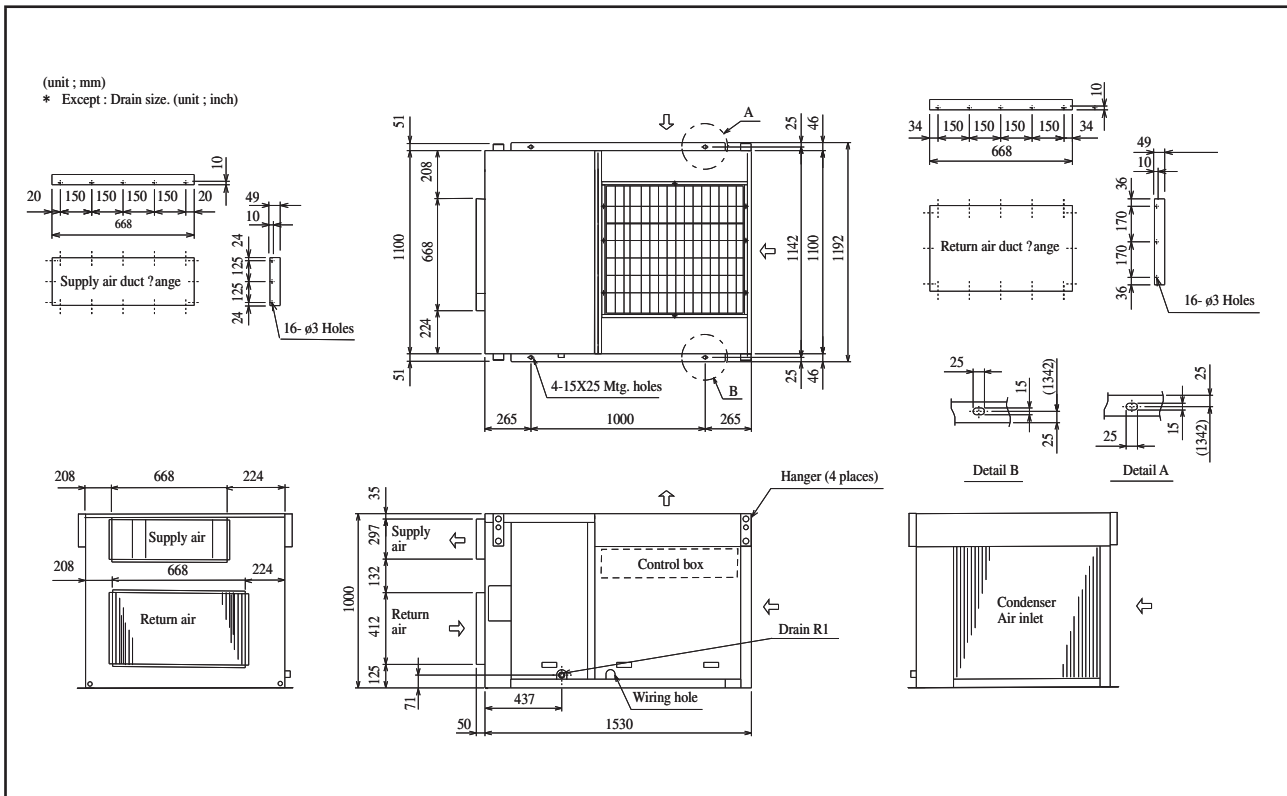

## Model: UAT(Y)P80/100/120A

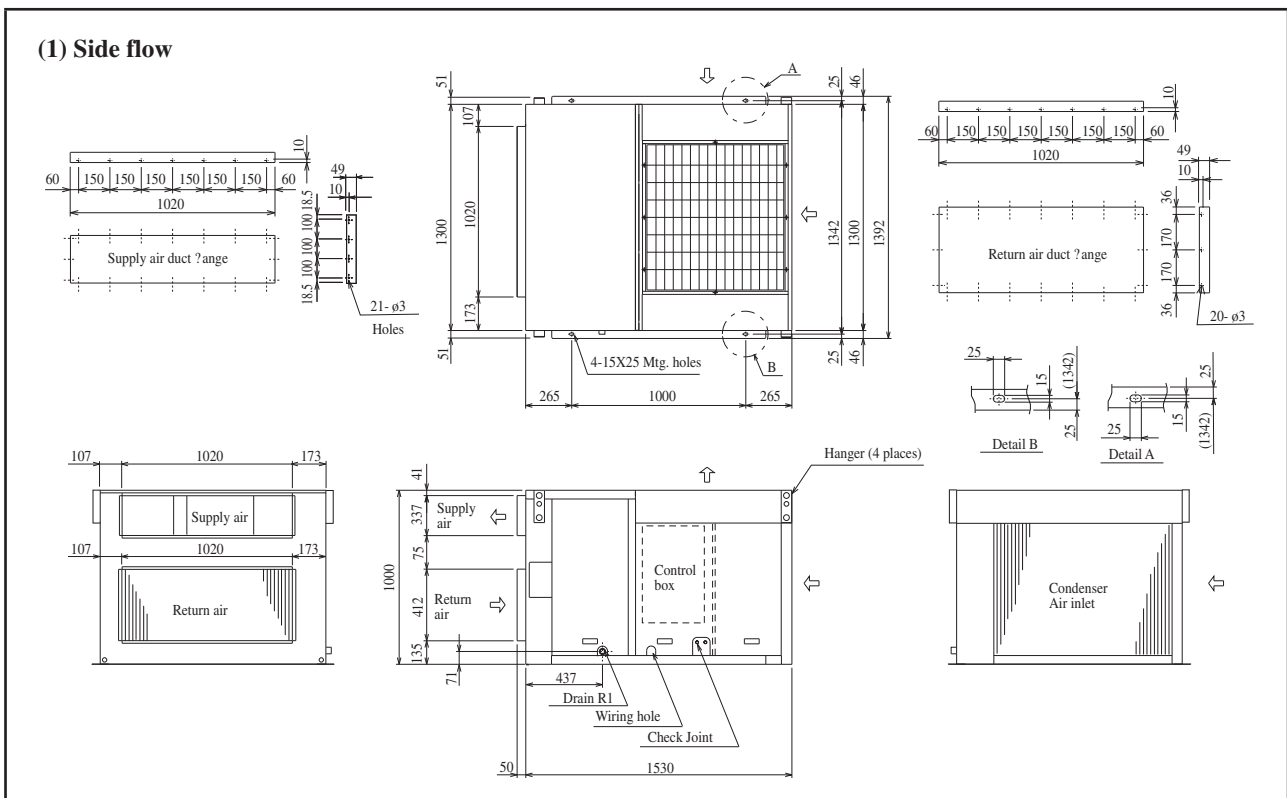

Model: UAT(Y)P80/100/120A

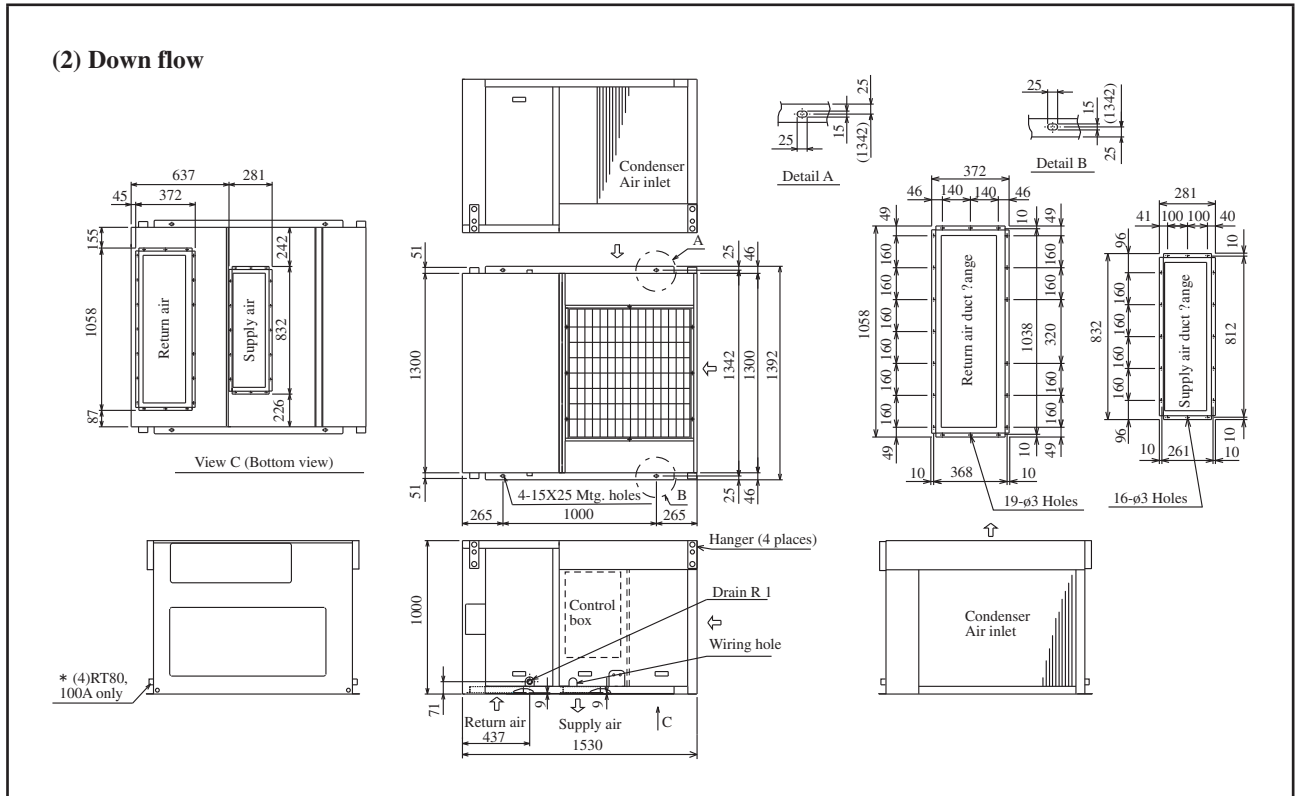

Model: UAT(Y)P150/200A

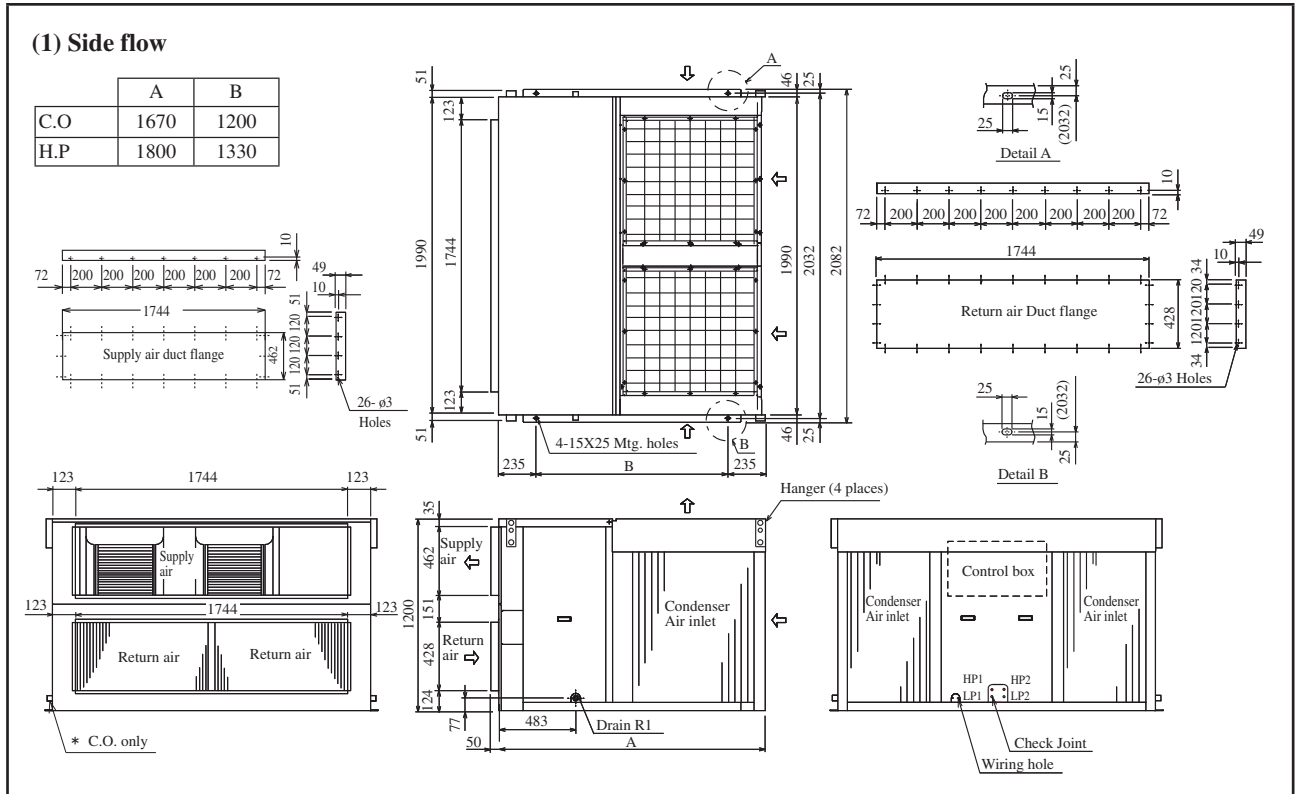



Model: UAT(Y)P360/420A

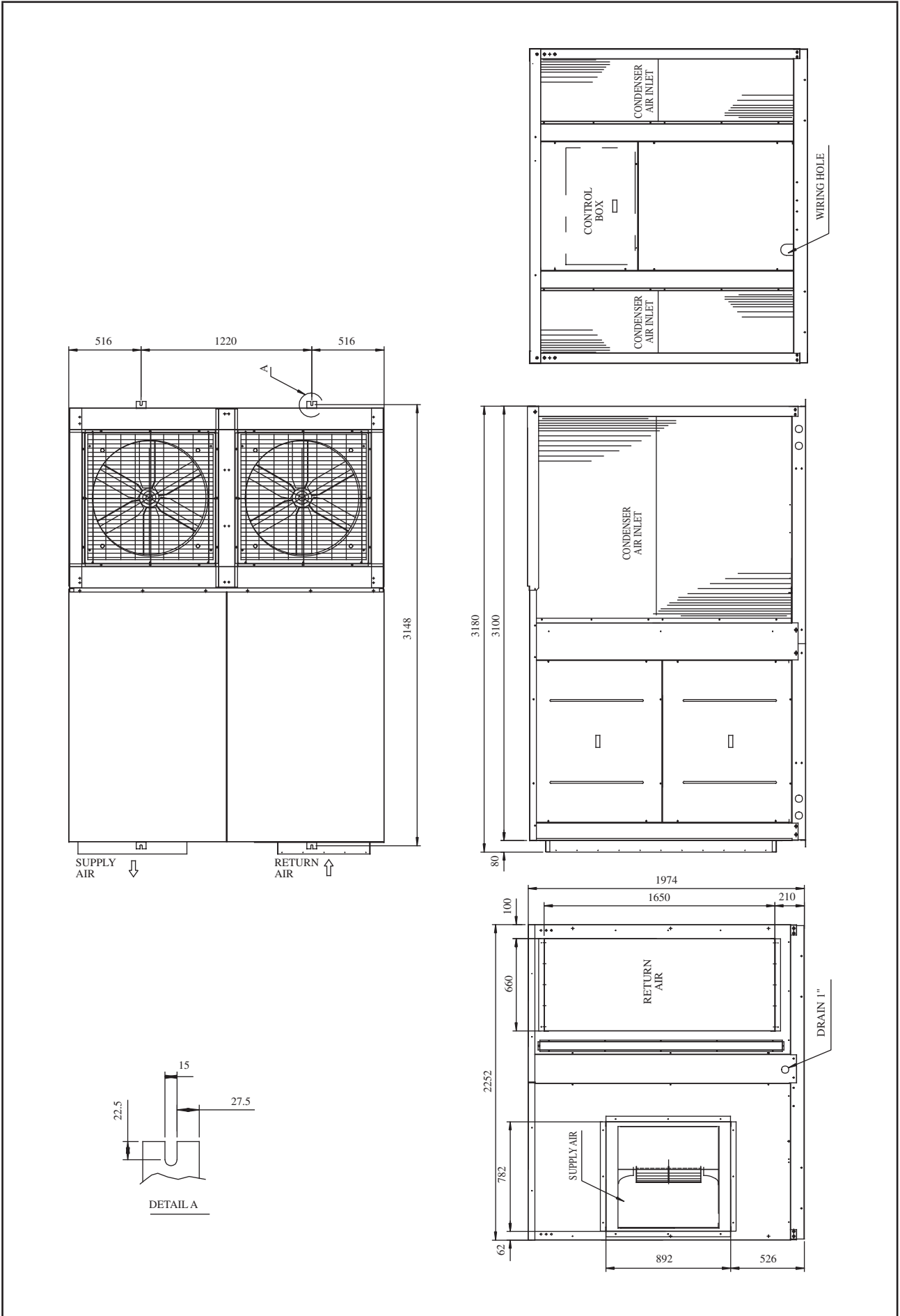

# Wiring Diagram

## Cooling Only

Model: UATP60AGXY1

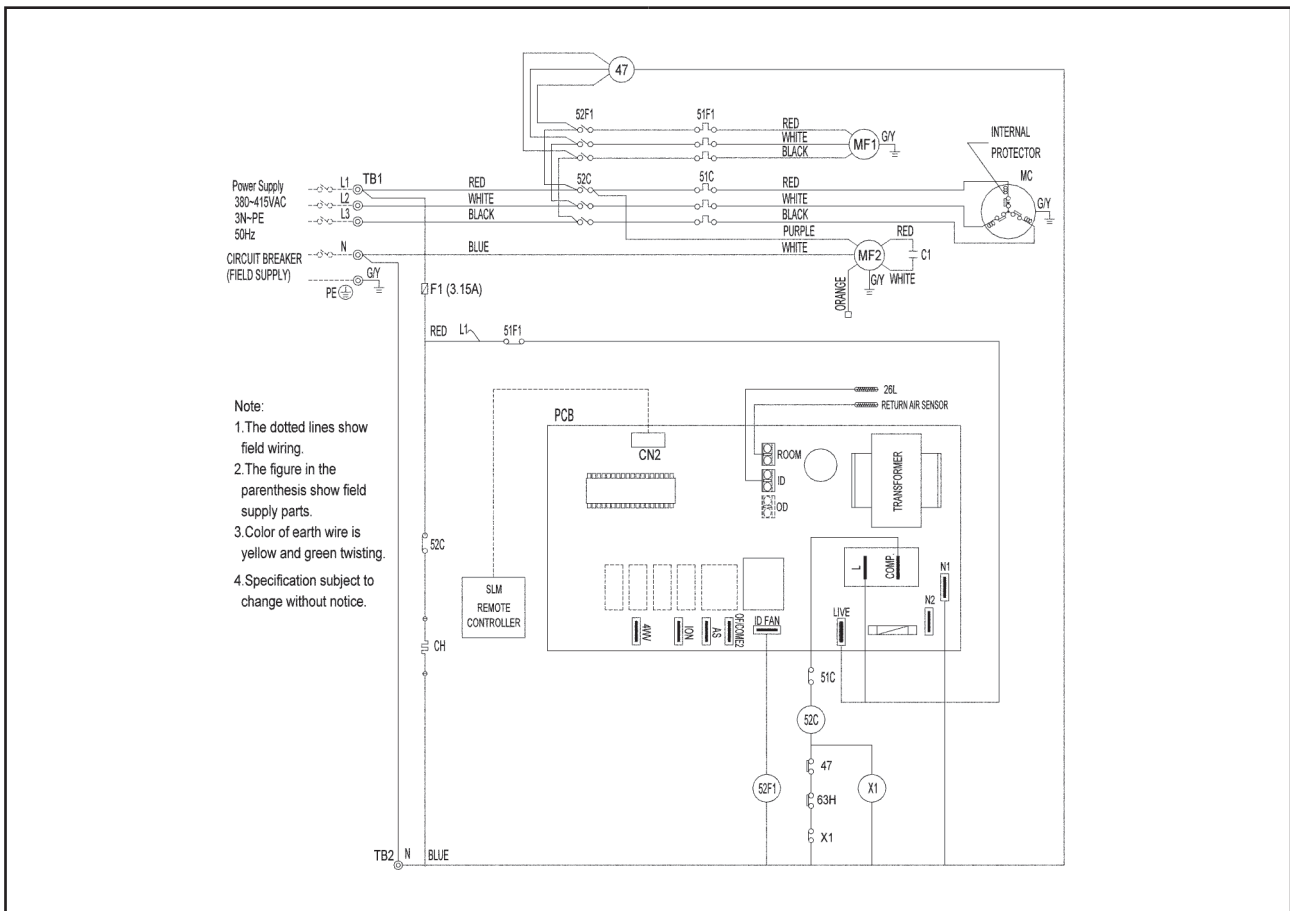

Model: UATP80/100/120AGXY1

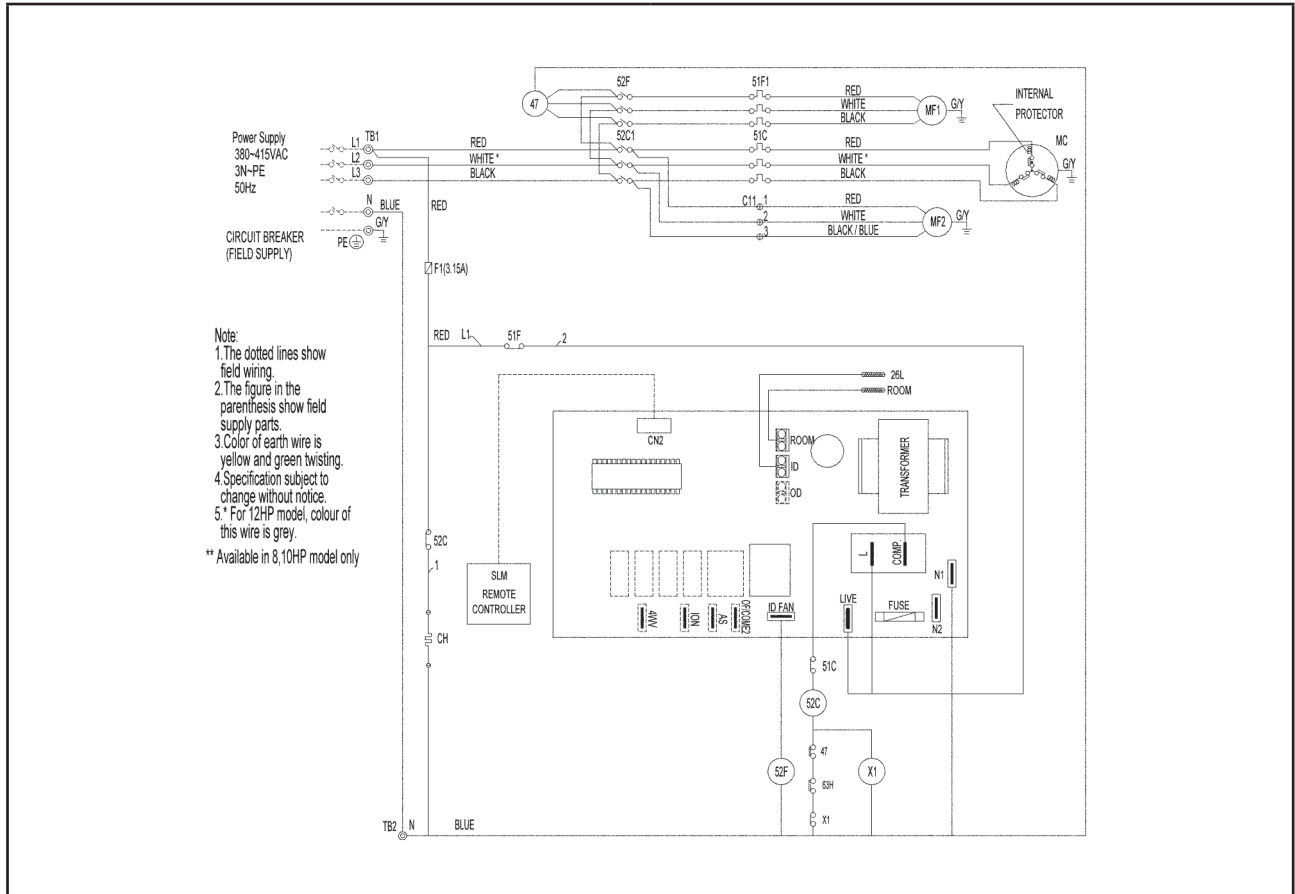

Model: UATP150/200AGXY1

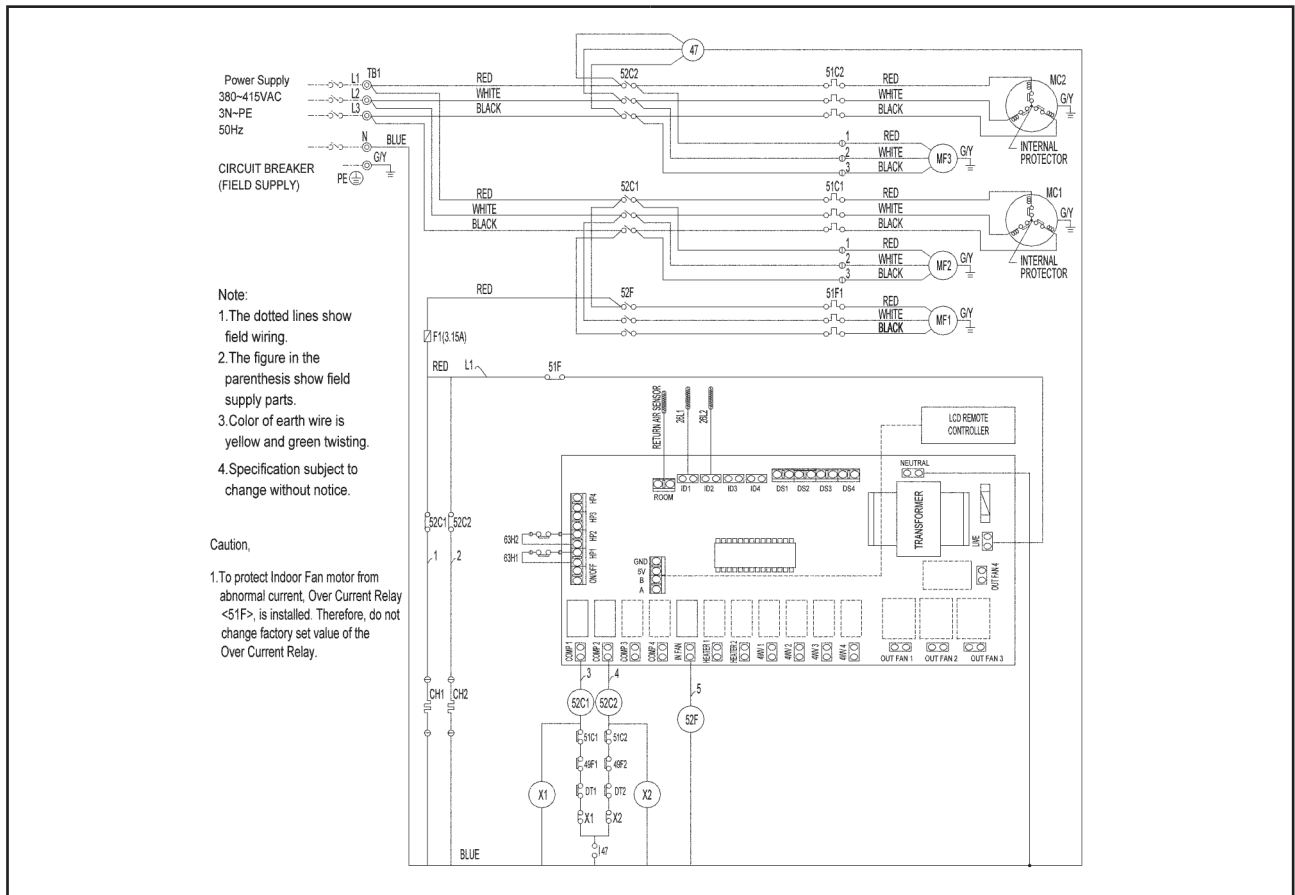

Model: UATP250AGXY1

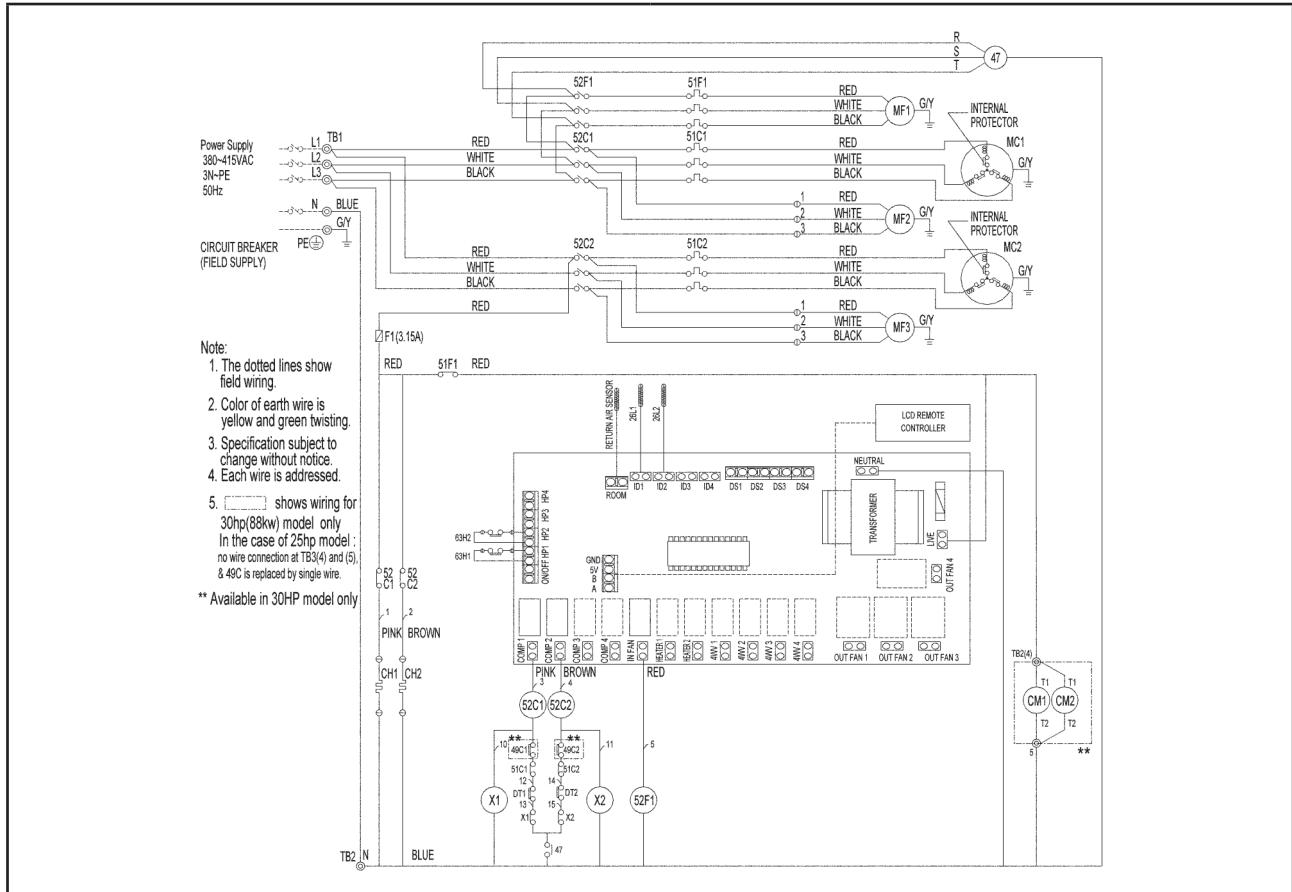

Model: UATP300AGXY1

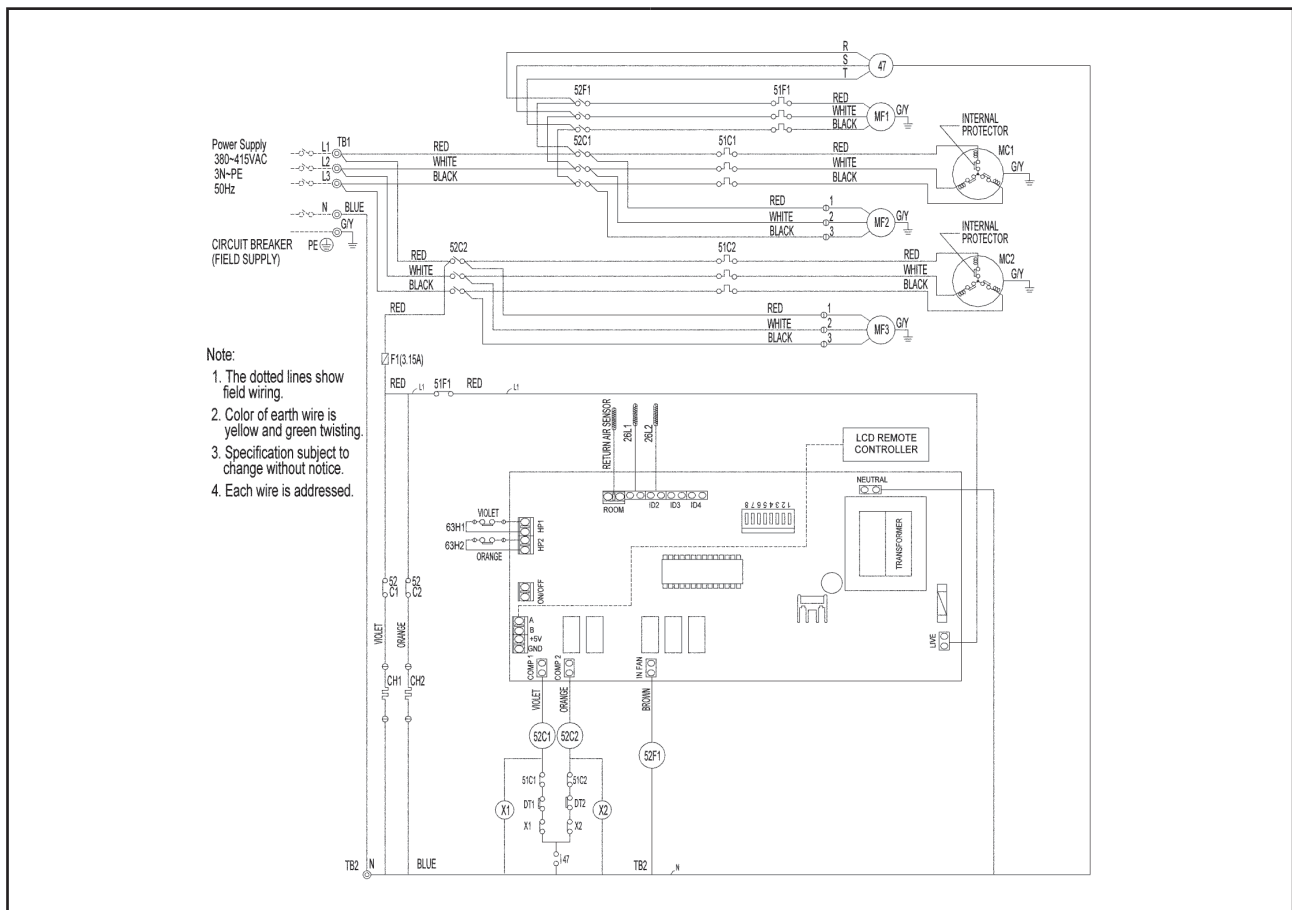

Model: UATP360/420AGXY1

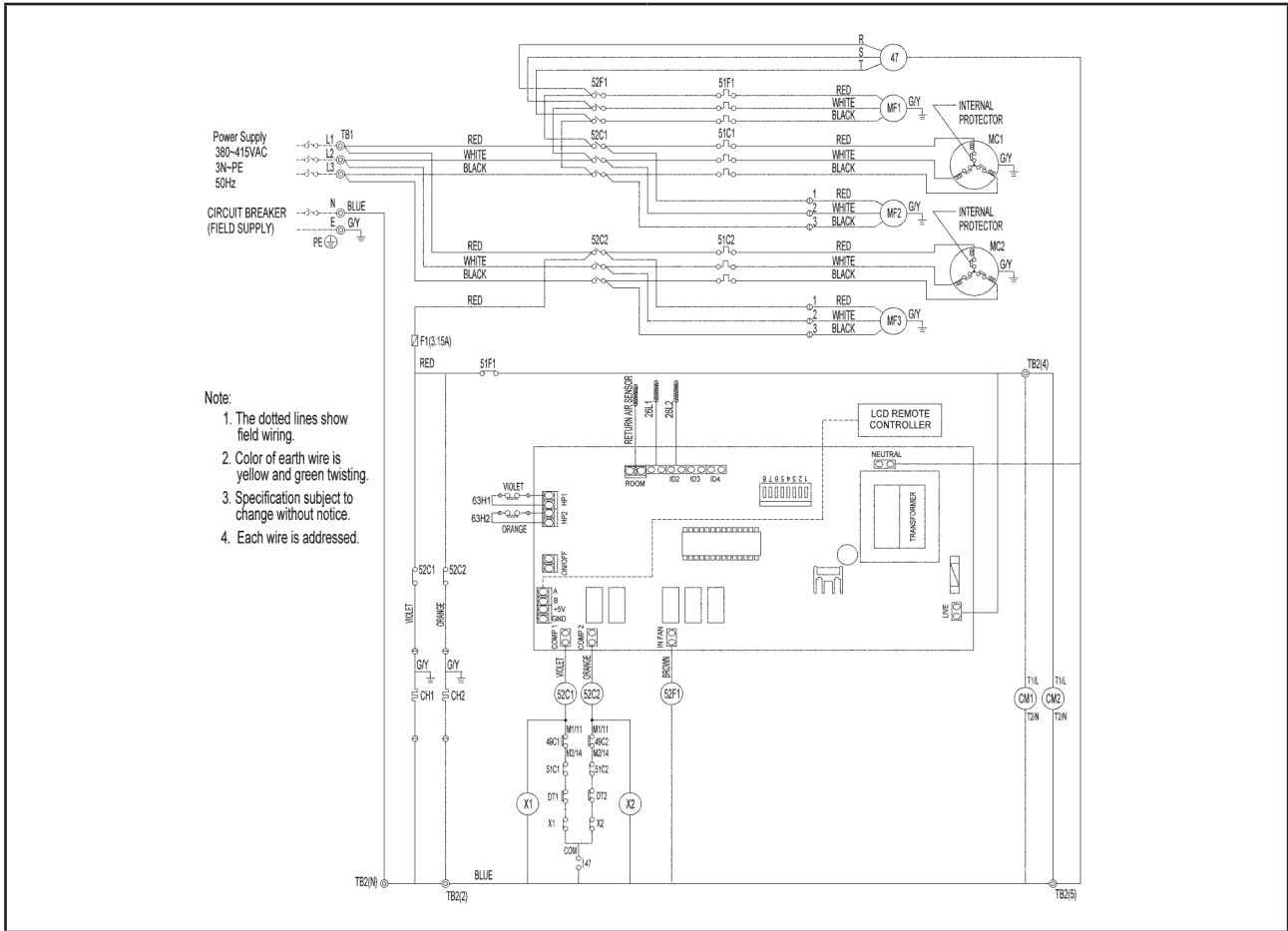

# Heatpump

Model: UATYP60AGXY1

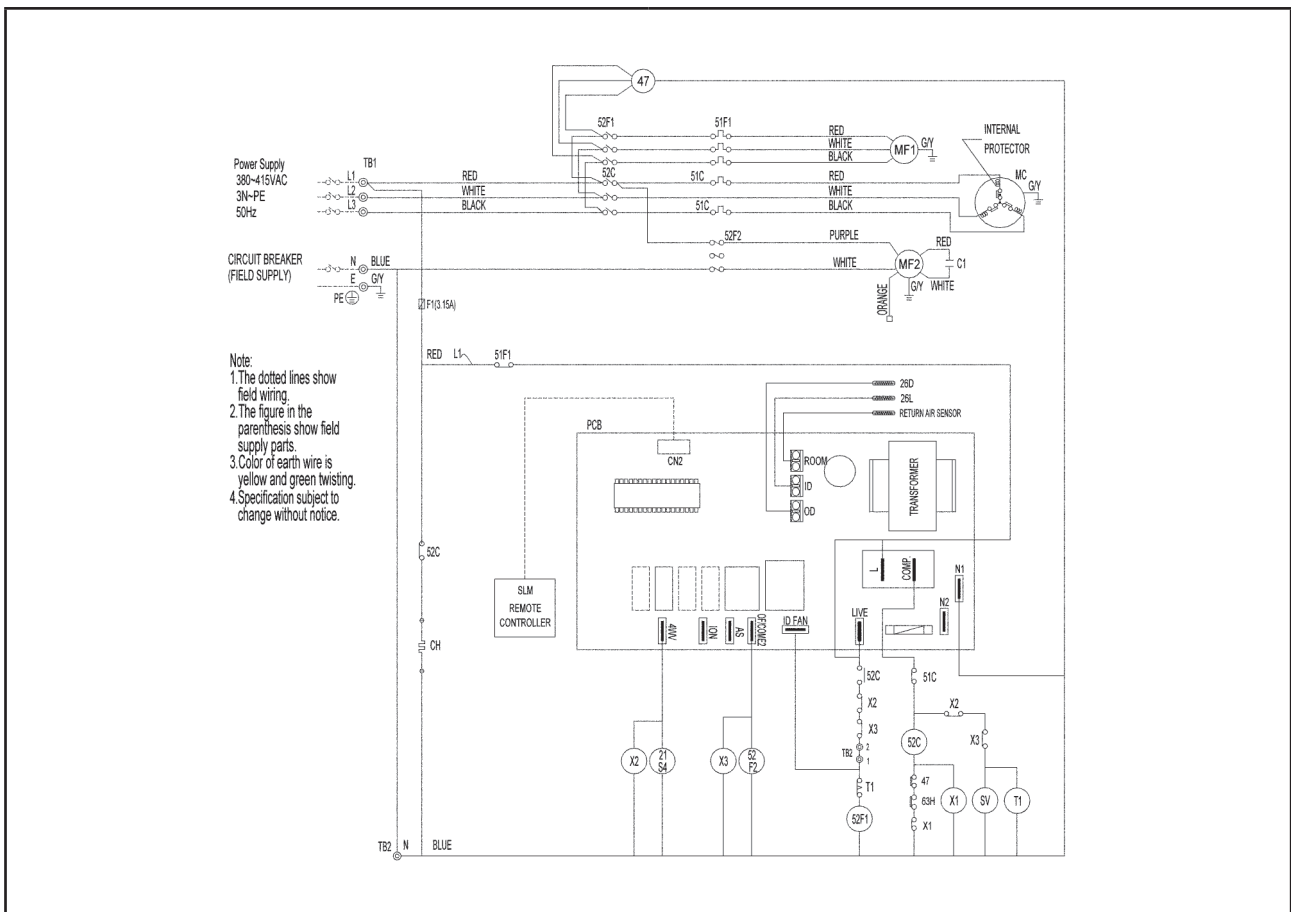

Model: UATYP80AGXY1

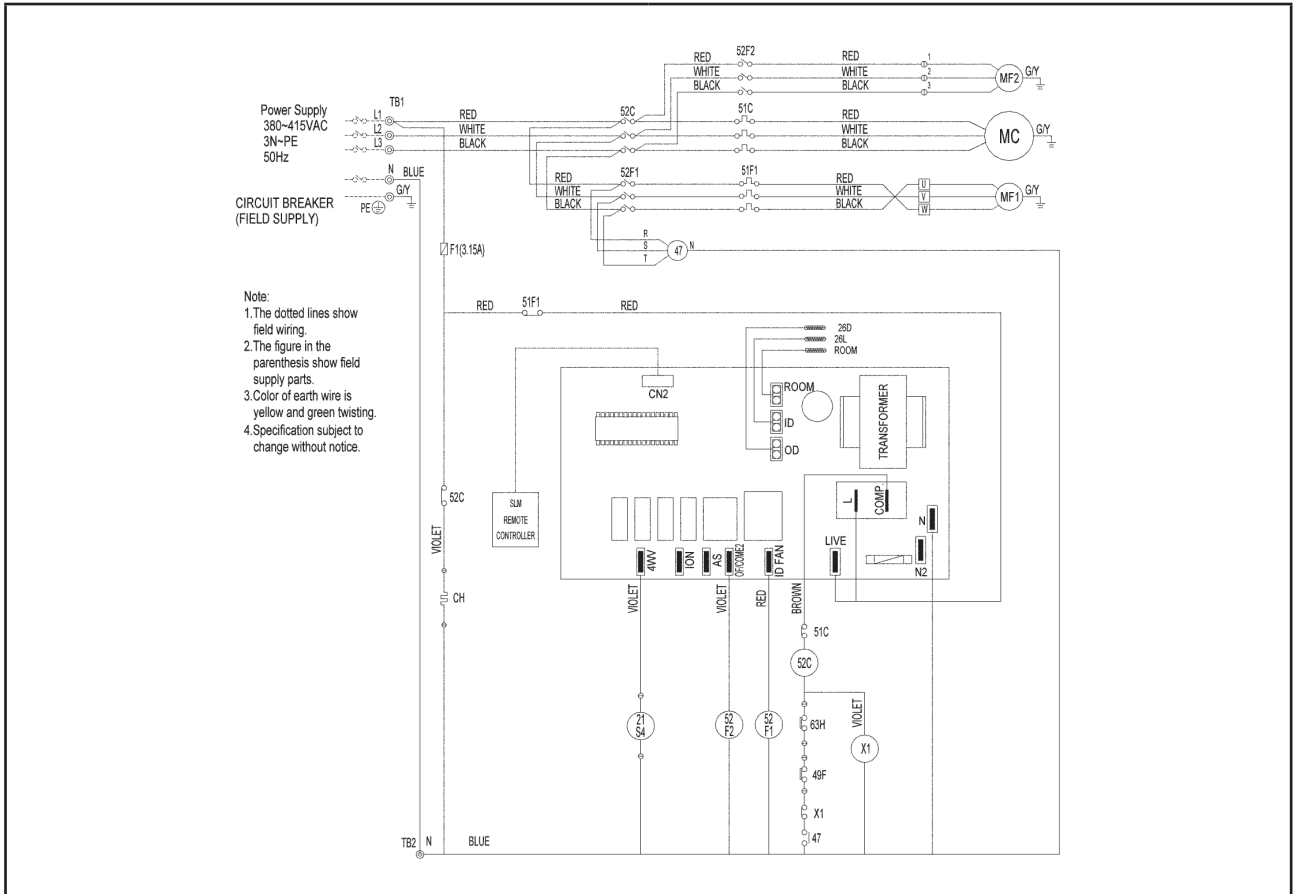

Model: UATYP100AGXY1

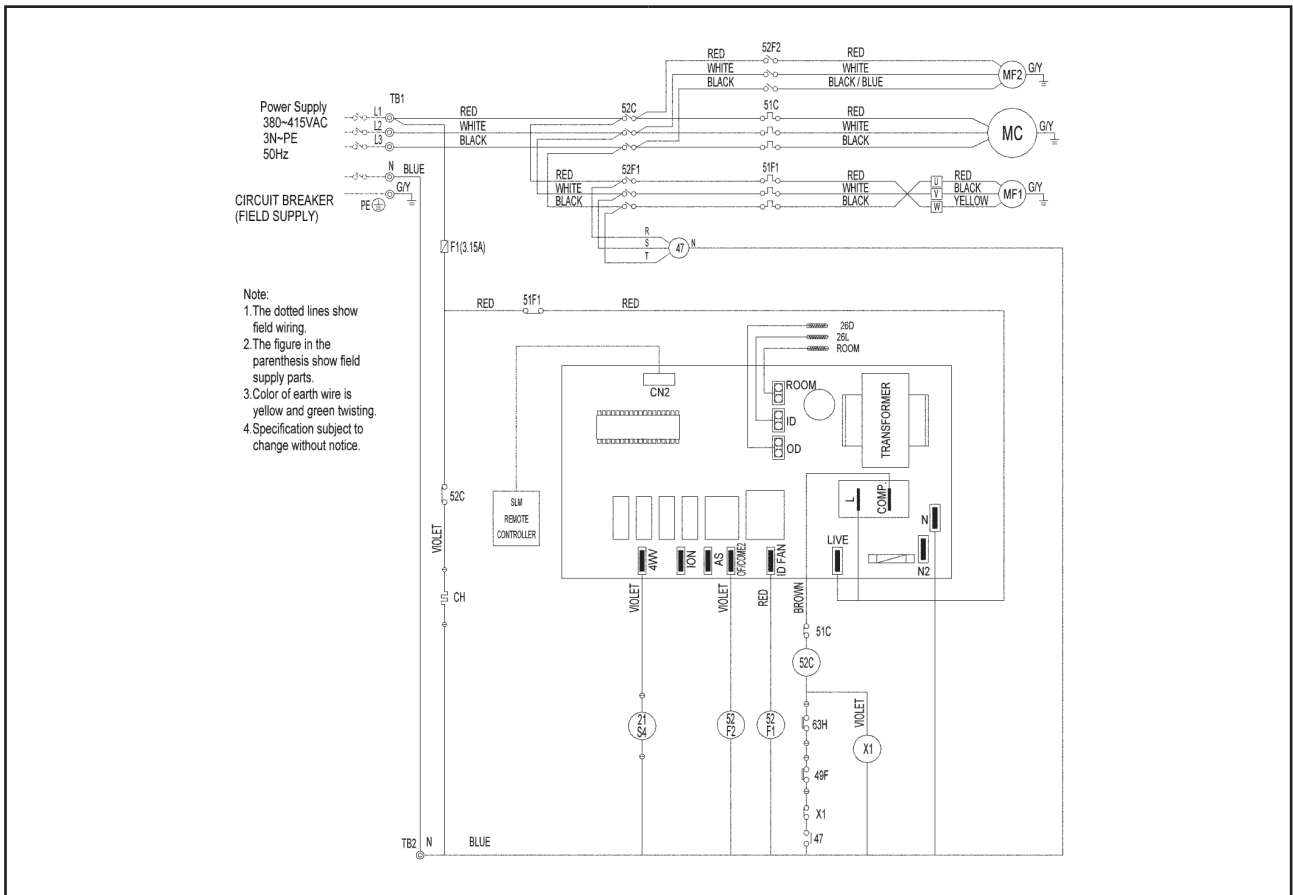

Model: UATYP120AGXY1

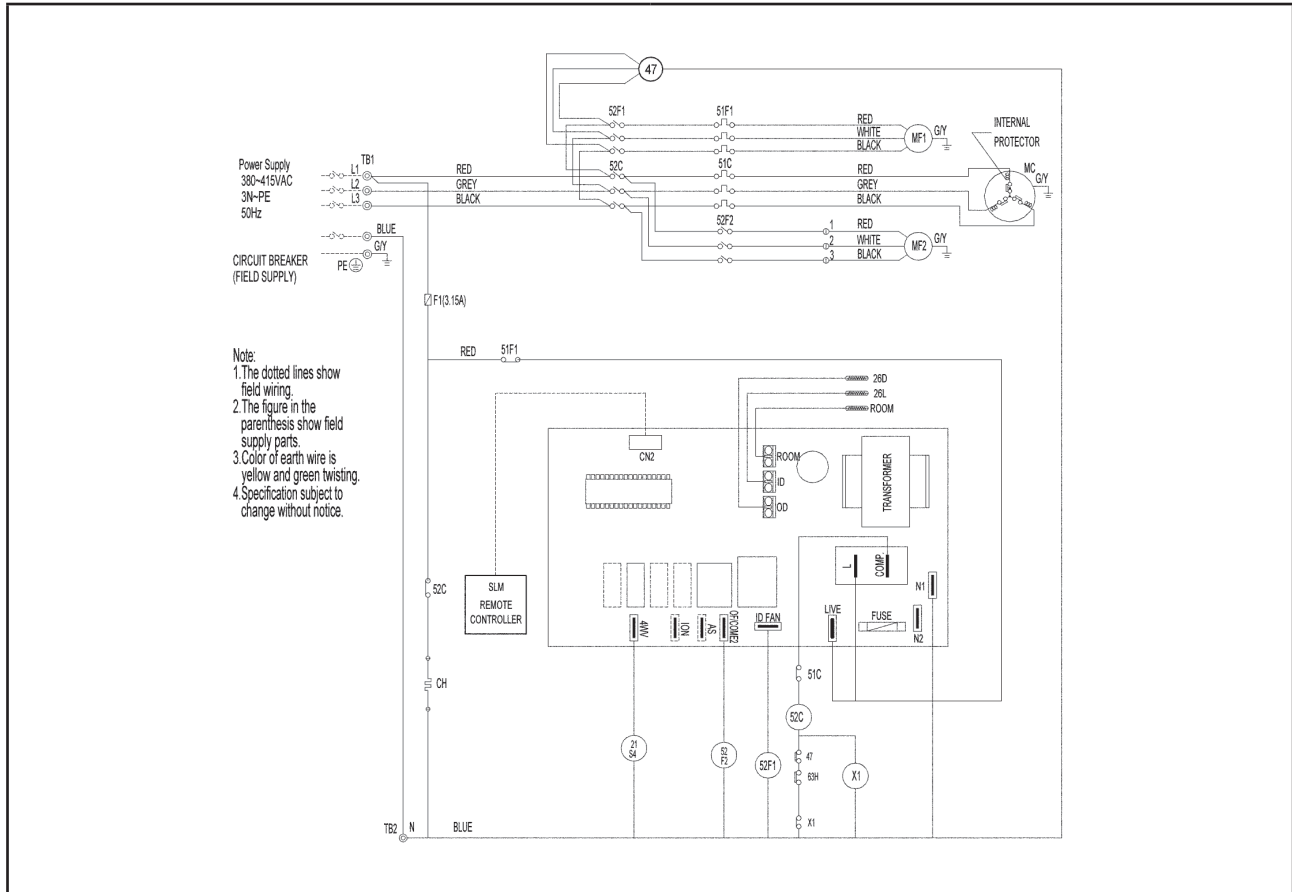

Model: UATYP150/200AGXY1

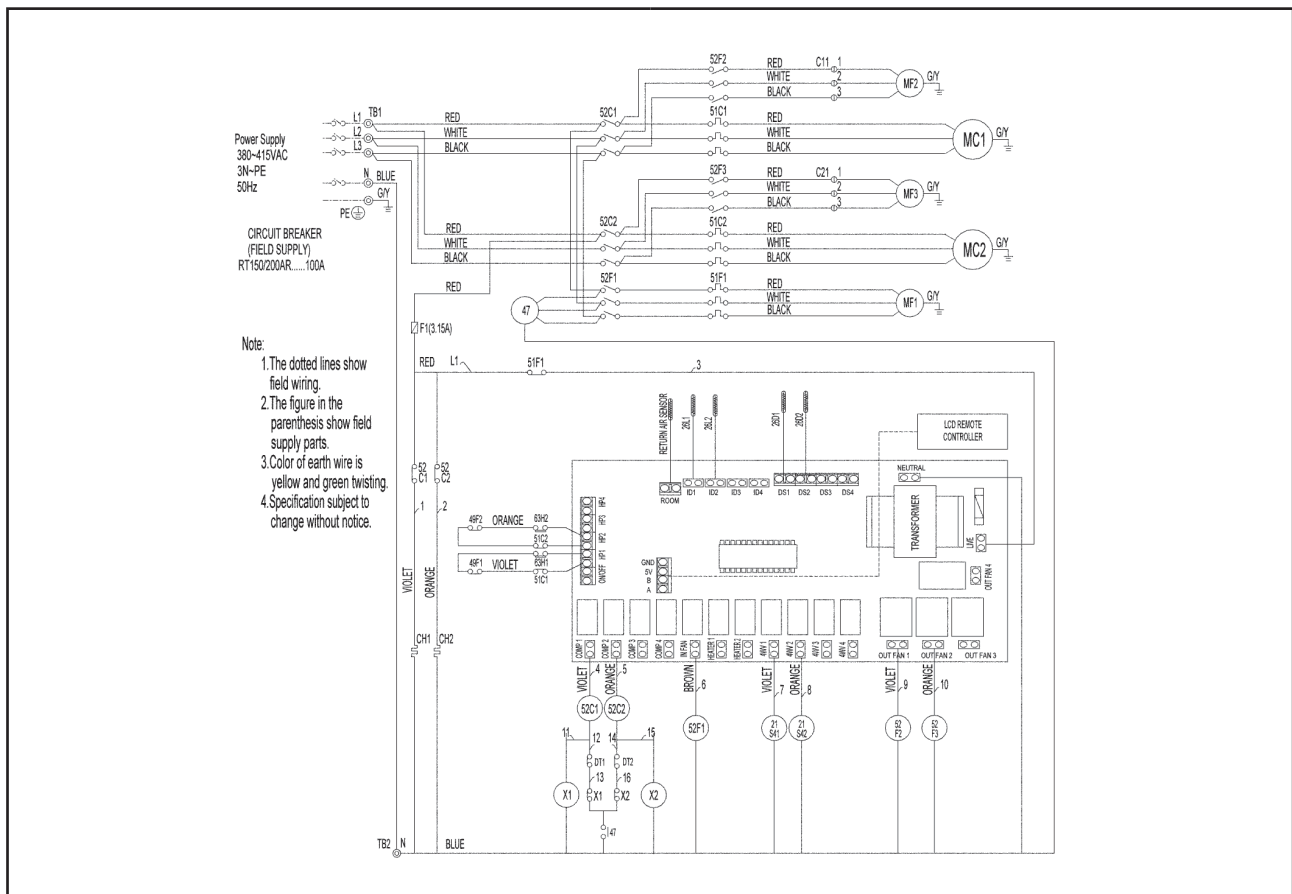

Model: UATYP250AGXY1

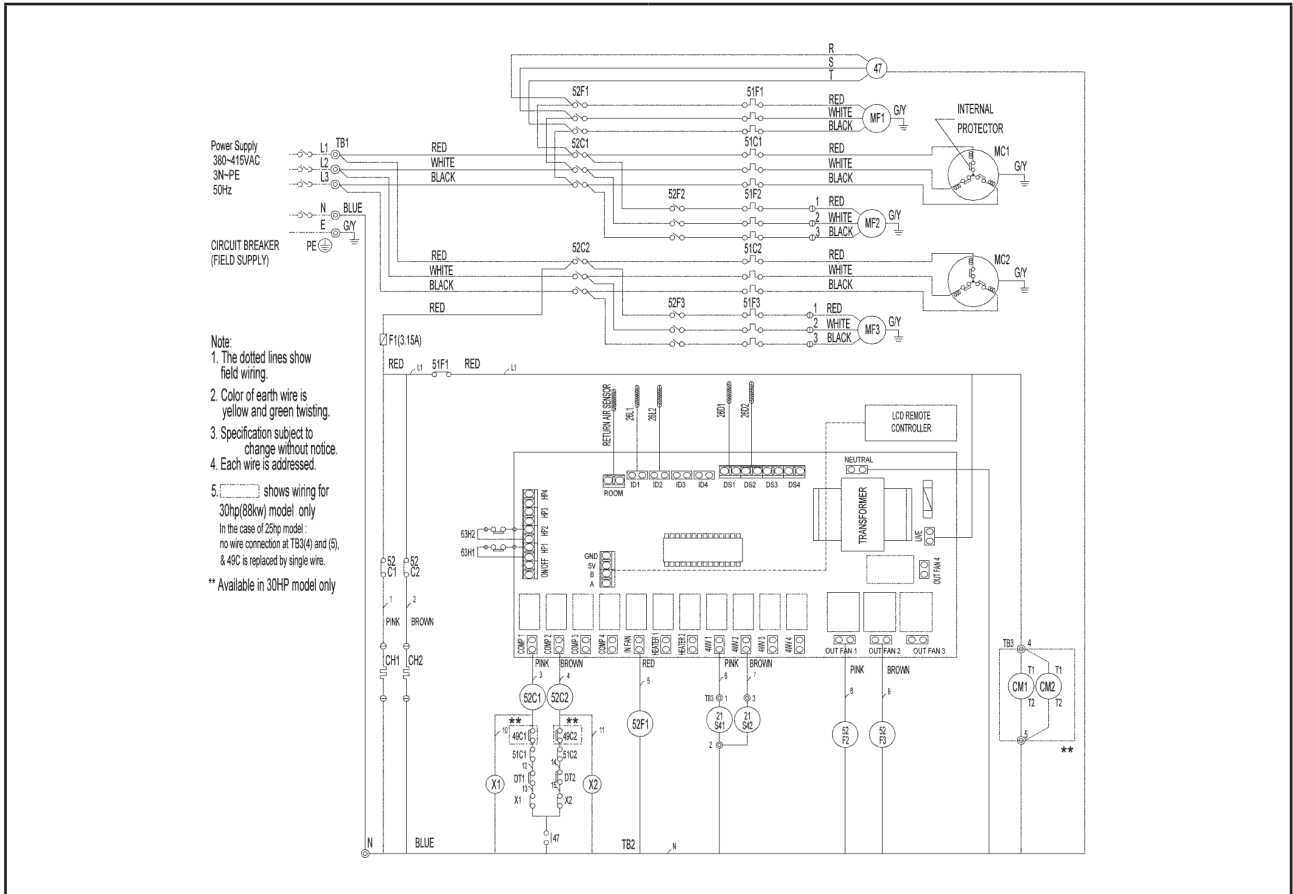

Model: UATYP300AGXY1

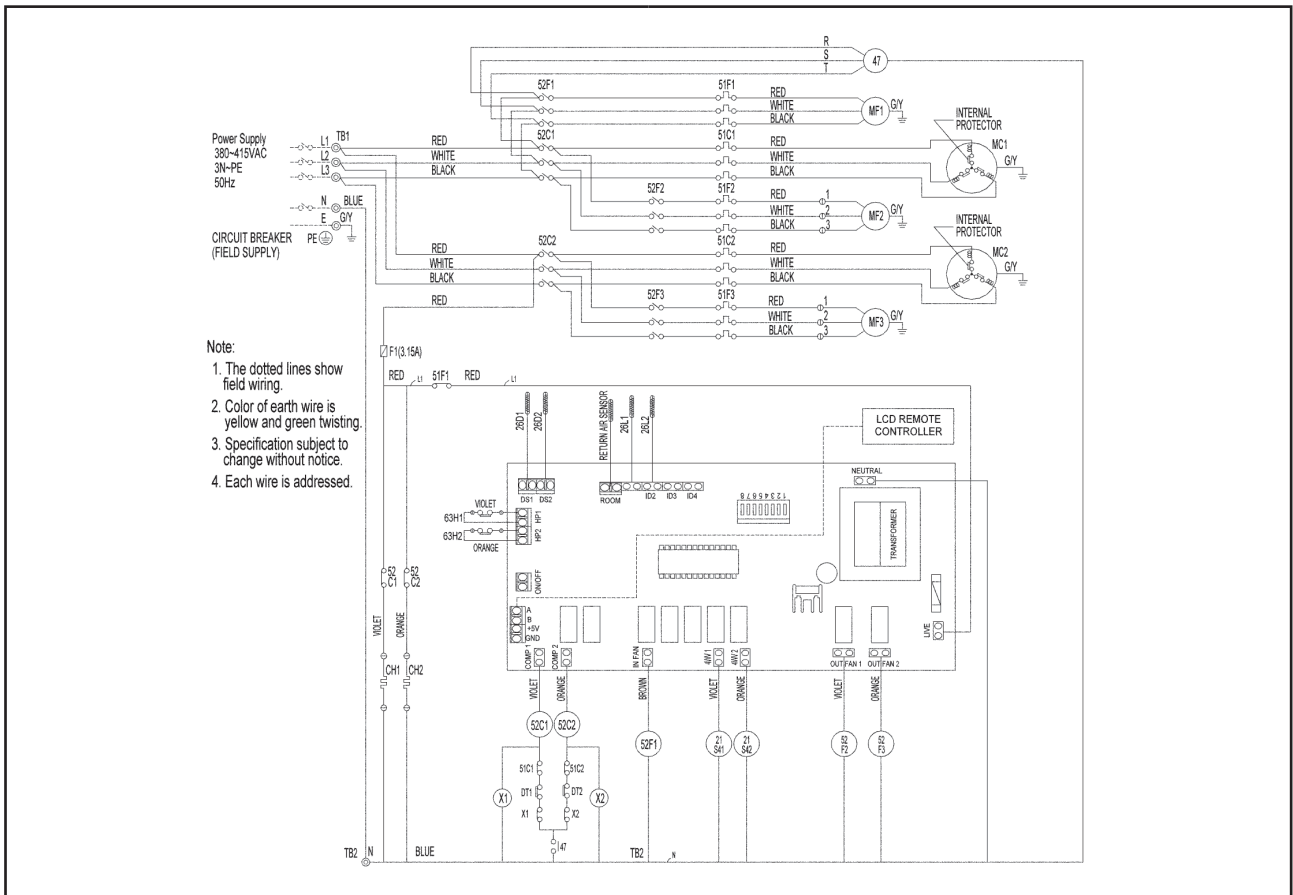

Model: UATYP360AGXY1

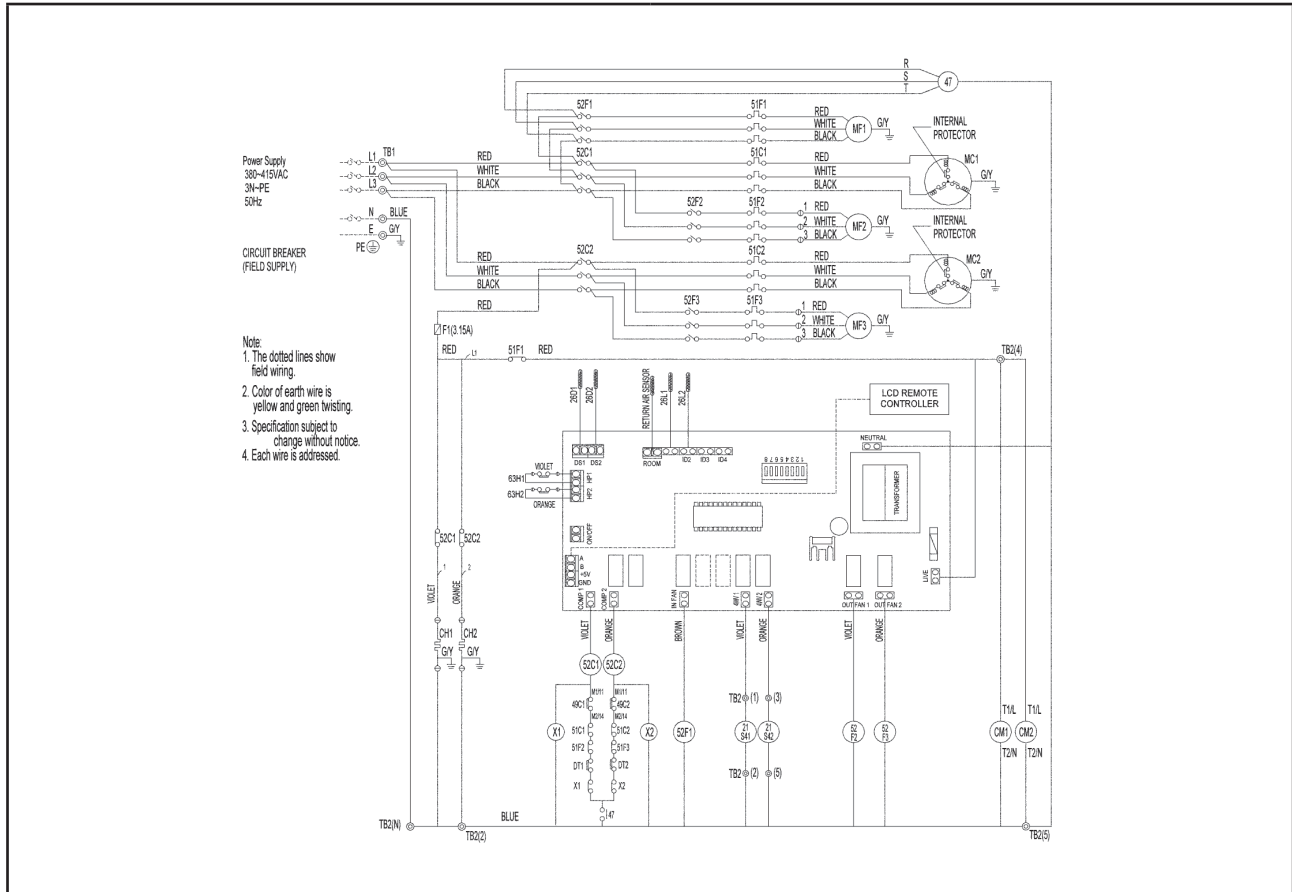

Model: UATYP420AGXY1

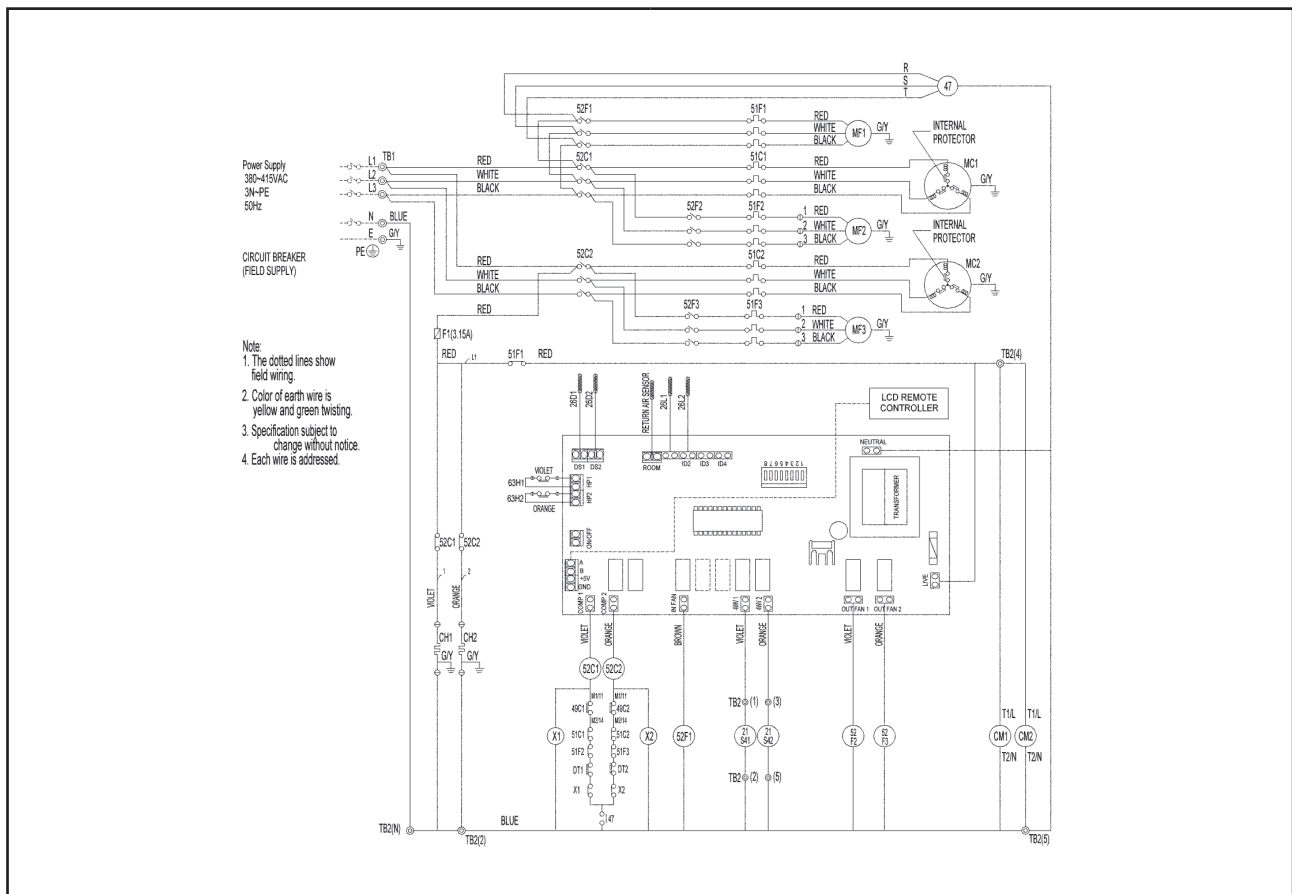

# Servicing & Maintenance

**For Superior Performance And Lasting Durability, Please Do Not Forget To Conduct Proper And Regular Maintenance.**

**Warning**

- 1. Do not wash the unit with water.**  
If washed with water, electrical shock may be caused.
- 2. Turn off power source.**  
For safety, turn the power source off before service work to avoid electrical shock.

## 1.1 Cleaning The Saranet Filter

The standard unit comes with a saranet filter. Clean the saranet filter about once a week with a neutral cleanser and leave it to dry in a shady location. If using an air filter which is special order or field supplied, please refer to filter supplier for maintenance and care instructions. Clean more regularly if the air filter gets very dirty. If the filter gets blocked, air will not be sucked in properly, and the cooling effect will deteriorate. Failure to clean the saranet filter may result in equipment breakdown or malfunction.

1. Removing the saranet filter.  
The saranet filter is mounted in the service panel.  
(in front of the heat exchanger.)

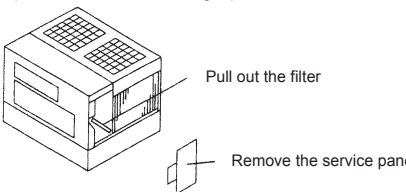

Pull out the filter

Remove the service panel

2. The saranet filter is cleaned with cleaner or washed in clear water.  
Please wash the dirty saranet filter in lukewarm water with neutral detergent. Please do not use hot water of 50°C or more, as it can deform the filter. Do not scrub or wring dry the filter as this can damage the filter. Rinse thoroughly and ensure there is no detergent remaining.

3. When the filter is washed in clear water, dry it under the shade.  
Please do not dry under direct sunshine and direct fire.

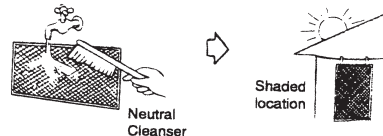

Neutral Cleanser

Shaded location

4. The saranet filter is installed as before.

## 1.2 Cleaning Of Panel

Clean dirt off panel as follows.  
Use a household neutral cleanser such as dishwashing liquid. Moisten a soft cloth with the cleanser, then wipe lightly. Next, wipe three or four times with another soft cloth moisten with water. Finally, wipe off all the remaining cleanser with a soft cloth.

Moisten a soft cloth with the alcohol, then wipe off lightly. Isopropyl alcohol is sold at stores as reagents in small quantities.

**Note:**  
Alcohol is highly combustible. Take extreme care when handling. Also, do not use paint or adhesive thinner.

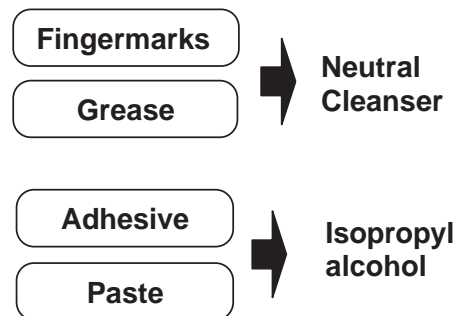

## 1.3 Cleaning The Outdoor Heat Exchanger

If you use your air conditioner for prolonged periods, the outdoor heat exchanger will become dirty, impairing its function and reducing the air conditioner's performance. Consult your equipment supplier or air conditioning contractor on how to clean the heat exchanger.

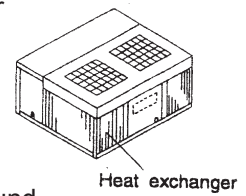

## 1.4 Starting The Air Conditioner After Service Works

Please turn on the power supply after checking is done and no abnormality is found. Please do the following work.

- It is confirmed that air inlet and outlet are not blocked.
  - It is confirmed that the earth connection line does not come off.
  - The earth connection line is firmly installed in the unit.
  - It is confirmed that there is neither lifting, blocking, nor bending of the drain-hose.
1. The controller is in the OFF position.
  2. The power supply switch is turned on.

### 1.5 When The Air Conditioner Is Not To Be Used For A Long Time

If the air conditioner is not to be used for a long time due to seasonal change, etc., Please do the following work.

1. The power supply switch is turned off.  
If the power supply is kept on, several watts or several tens of watts will be wasted.  
The accumulation of dust, etc., can result in fire.
2. Filter, and drain pan must be cleaned. Pay attention to clean dust in the drain.
3. Run it for 4-5 hours with the air blowing until the inside is completely dry.  
Failing to do so can result in the growth of unhygienic, unhealthy mold in scattered areas throughout the room.

### 1.6 In Case Of Failure

- (1) Never remodel the air conditioner by yourself. Consult your dealer for any repair service.  
Improper repair work can result in water leakage, electric shock, fire, etc.
- (2) If the power breaker is frequently activated, get in touch with your dealer.  
Leaving the unit as it is under such conditions can result in fire or failure.
- (3) If refrigerant gas blows out or leaks, stop the operation of the air conditioner.  
Thoroughly ventilate the room, and contact your dealer.  
Leaving the unit as it is can result in accidents due to oxygen deficiency.

## 2. Transferring Work And Construction

### 2.1 Transfer Of Installation

- (1) When removing and reinstalling the air conditioner, consult with your dealer in advance to ascertain the cost of the professional engineering work required for transferring the installation.
- (2) Please do not use refrigerant other than the specified refrigerant when you top-up/recharge the refrigerant at the new installation site .
- (3) When moving or reinstalling the air conditioner, consult with your dealer.  
Defective installation can result in electric shock, fire, etc.

### 2.2 Place For Installation

Please do not use the unit in the following places.

- (1) Places with a lot of oil, moisture, and dust.
- (2) Places with high salinities such as seaside.
- (3) Places where sulfur gas, volatile gas, and corroded gas are filled.
- (4) Places where acid solution is frequently used.
- (5) Places where special spray is frequently used.
- (6) Hot spring zones.
- (7) Near to machines that generate high cycles (High cycle welding machine etc.).
- (8) Places where ventilation entrance of unit is closed by snowfall.
- (9) The unit must be installed on stable, level surface.  
The consequence of using a unit in the places mentioned above is the main body might corrode, the refrigerant might leak, the performance of the unit might decrease remarkably, and it might cause damage of parts in the unit.

### 2.3 Regarding Electric Work

- (1) The electrical work must be undertaken by a person who is qualified as an electrical technician with respect to local governing laws.
- (2) Please install the earth connection for the electric shock prevention.
- (3) Never connect the grounding wire to a gas pipe, water pipe, arrestor, or telephone grounding wires. For details, consult with your dealer.
- (4) In some types of installation sites, the installation of an earth leakage breaker is mandatory. For details, consult with your dealer.
- (5) The breaker and the fuse must be of correct capacity.

#### **2.4 Consideration Of The Noise**

- (1) Take sufficient measures against noise when installing the air conditioners at hospitals or communications related businesses.
- (2) If the air conditioner is used in any of the above-mentioned environments, frequent operational failure can be expected. It is advisable to avoid these type of installation sites. For further details, consult with your dealer.
- (3) Choose a place where cool air and noise from the outdoor air outlet of the air conditioner do not inconvenience the neighbors.
- (4) Obstacles placed near the air outlet of the unit can decrease performance and increase noise. Avoid placing any obstacles adjacent to the air outlet.
- (5) If the air conditioner produces any abnormal sound, consult your dealer.

#### **2.5 Disposing Of The Unit**

When you need to dispose of the unit, consult your dealer.

If pipes are removed incorrectly, refrigerant (fluorocarbon gas) may blow out and come into contact with your skin, causing injury. Releasing refrigerant into the atmosphere also damages the environments.

#### **2.6 Maintenance And Inspection**

- (1) If the air conditioner is used throughout several seasons, the inside can get dirty and eventually reduce the performance.
- (2) Depending upon the conditions of usage, foul odors can be generated and drainage can deteriorate due to dust, dirt, etc.

# Troubleshooting

When a malfunction of the air conditioner unit is detected, immediately switch off the main power supply before proceeding with the following troubleshooting procedures.

The following are common fault conditions and simple troubleshooting tips. If any other fault conditions which are not listed occur, contact your nearest local dealer. DO NOT attempt to troubleshoot the unit by yourself.

No	Fault conditions	Possible causes / corrective actions
1	The air conditioner unit will not resume after power failure.	<ul style="list-style-type: none"> <li>The auto restart function is not functioning. Please turn on the unit with the wireless / wired controller.</li> </ul>
2	The compressor does not operate 3 minutes after the air conditioner unit is started.	<ul style="list-style-type: none"> <li>Protection against frequent starting.</li> <li>Wait for 3 or 4 minutes for the compressor to start operating by itself.</li> </ul>
3	The airflow is too slow or room cannot be cooled sufficiently.	<ul style="list-style-type: none"> <li>The air filter is dirty.</li> <li>The doors and windows are opened.</li> <li>The air suction and discharge of both indoor and outdoor units are clogged or blocked.</li> <li>The regulated temperature or temperature setting is not low enough.</li> </ul>
4	Discharge airflow has bad odor.	<ul style="list-style-type: none"> <li>Cigarettes, smoke particles, perfume and others, which might have adhered onto the coil, may cause odor.</li> <li>Contact your nearest dealer.</li> </ul>
5	Condensation on the front air grille of the indoor unit.	<ul style="list-style-type: none"> <li>This is caused by air humidity after an extended period of operation.</li> <li>The set temperature is too low. Increase the temperature setting and operate the unit at high fan speed.</li> </ul>
6	Water flowing out from the air conditioner.	<ul style="list-style-type: none"> <li>Switch off the unit and contact your nearest dealer. This might be due to tilted installation.</li> </ul>
7	Hissing airflow sound from the air conditioner unit during operation.	<ul style="list-style-type: none"> <li>Liquid refrigerant flowing into the evaporator coil.</li> </ul>
8	The wireless controller display is dim.	<ul style="list-style-type: none"> <li>The batteries are discharged.</li> <li>The batteries are not correctly inserted.</li> <li>The assembly is not good.</li> </ul>
9	Compressor operates continuously.	<ul style="list-style-type: none"> <li>Dirty air filter. Clean the air filter.</li> <li>Temperature setting too low (cooling). Use higher temperature setting.</li> <li>Temperature setting too high (heating), Use lower temperature setting.</li> </ul>
10	No cool air comes out during cooling cycle, or no hot air comes out during heating cycle.	<ul style="list-style-type: none"> <li>Temperature setting too high (cooling). Use lower temperature setting.</li> <li>Temperature setting too low (heating). Use higher temperature setting.</li> </ul>
11	On heating cycle, warm air does not come out.	<ul style="list-style-type: none"> <li>Unit is in defrost mode. Heating operation will resume after defrost cycle ends.</li> </ul>

## Diagnostic Guidelines

By means of pressure readings:

Circuit	Data	Pressure					Prabable cause
		Too low	A little low	Normal	A little high	Too high	
High side Low side						• •	<ol style="list-style-type: none"> <li>Overcharged with refrigerant.</li> <li>Non-condensable gases in refrigerant circuit (e.g. air)</li> <li>Obstructed air-intake / discharge.</li> <li>Hot air short circuiting in outdoor unit.</li> </ol>
High side Low side	•					•	<ol style="list-style-type: none"> <li>Poor compression / no compression (compressor defective)</li> <li>Reversing valve leaking.</li> </ol>
High side Low side	•	•					<ol style="list-style-type: none"> <li>Undercharged with refrigerant.</li> <li>Refrigerant leakage.</li> <li>Air filter clogged / dirty (indoor unit).</li> <li>Indoor fan locked / seized.</li> <li>Defective defrost control, outdoor coil freeze up (heating).</li> <li>Outdoor fan locked / seized (heating).</li> </ol>
High side Low side				•		•	<ol style="list-style-type: none"> <li>Outdoor fan blocked (cooling).</li> <li>Outdoor coil dirty (cooling).</li> <li>Indoor fan locked / seized (heating).</li> <li>Indoor air filter clogged / dirty (heating).</li> <li>Non-condensable gases in refrigerant circuit (e.g. air)</li> </ol>
High side Low side				•		•	<ol style="list-style-type: none"> <li>Air intake temperature of indoor unit too high.</li> </ol>

**By Means of Diagnostic Flow Chart:**

Generally, there are two kinds of problems, i.e. starting failure and insufficient cooling/heating. "Starting failure" is caused by electrical defect while improper application or defects in refrigerant circuit causes "Insufficient cooling / heating".

**i) Diagnosis of Electric Circuit**

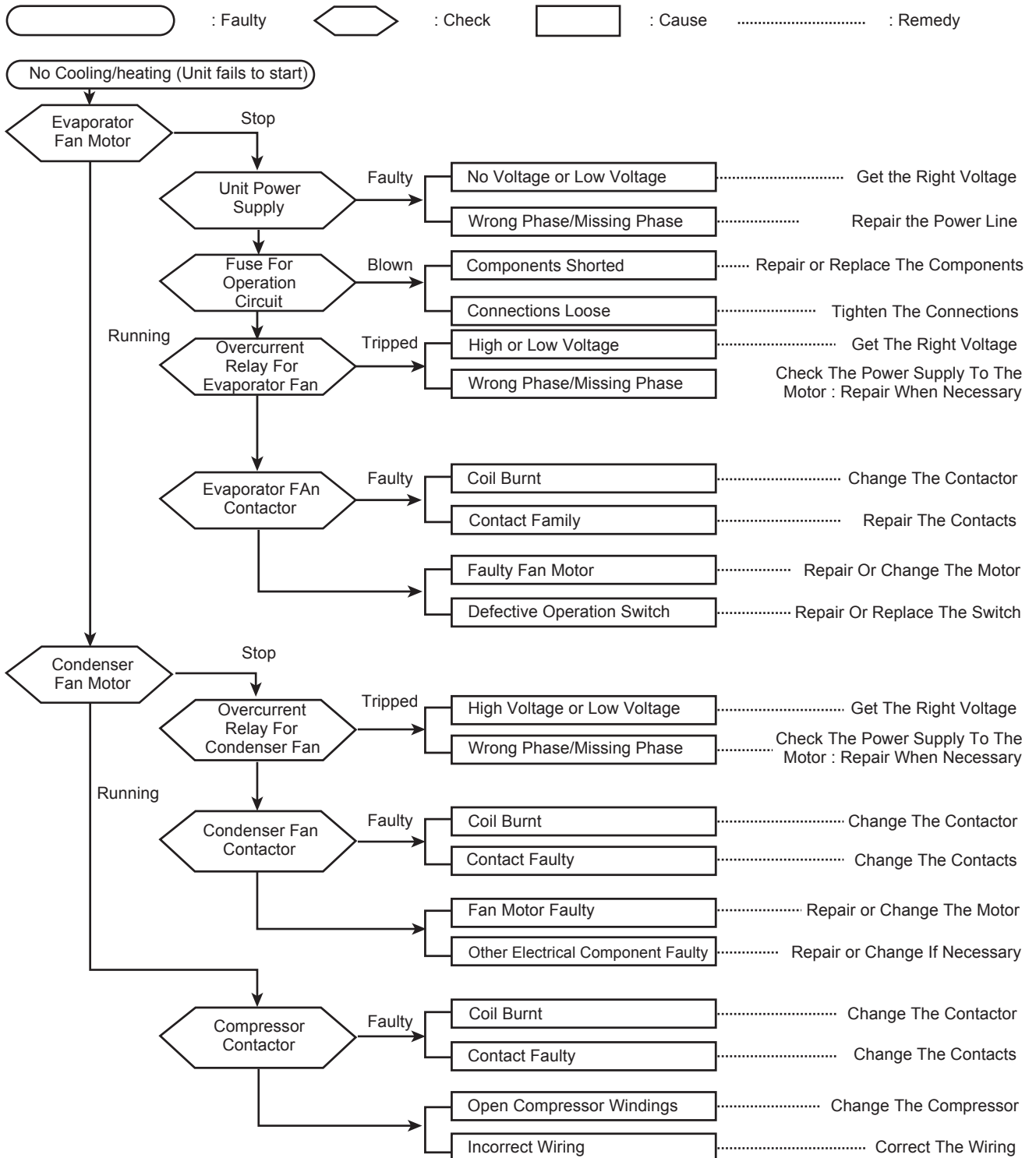

The most common causes of air conditioner failure to "start" are :

- a) Voltage not within  $\pm 10\%$  of rated voltage.
- b) Power supply interrupted.
- c) Improper control settings.
- d) Air conditioner is disconnected from main power source.
- e) Fuse blown or circuit breaker off.

## ii) Diagnosis of Refrigerant Circuit / Application

There might be some causes where the unit starts running but does not perform satisfactorily, i.e. insufficient cooling. Judgement could be made by measuring temperature difference of indoor unit's intake and discharge air as well as running current.

