



Internal Use Only

<http://biz.lgservice.com>

MULTI V ™
Outdoor Unit **R410A**
SERVICE MANUAL

MODEL : ARUN Series
ARUV Series

CAUTION

Before Servicing the unit, read the safety precautions in General SVC manual.
Only for authorized service personnel.

TABLE OF CONTENTS

Safety Precautions	3
Part 1 General Information	10
Model Names	11
External Appearance	13
Combination of Outdoor Units	17
Nomenclature	19
Outdoor Units Information	16
Part 2 Outdoor Units	20
Part 3 PCB Setting and Test Run	54
Part 4 Trouble shooting guide	61

Safety Precautions

To prevent injury to the user or other people and property damage, the following instructions must be followed.

n Incorrect operation due to ignoring instruction will cause harm or damage. The seriousness is classified by the following indications.

⚠ WARNING This symbol indicates the possibility of death or serious injury.

⚠ CAUTION This symbol indicates the possibility of injury or damage to properties only.

n Meanings of symbols used in this manual are as shown below.

	Be sure not to do.
	Be sure to follow the instruction.

⚠ WARNING

n Installation

Have all electric work done by a licensed electrician according to "Electric Facility Engineering Standard" and "Interior Wire Regulations" and the instructions given in this manual and always use a special circuit.

- If the power source capacity is inadequate or electric work is performed improperly, electric shock or fire may result.

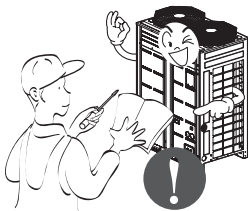

Ask the dealer or an authorized technician to install the air conditioner.

- Improper installation by the user may result in water leakage, electric shock, or fire.

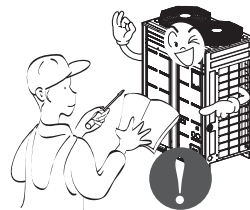

Always ground the product.

- There is risk of fire or electric shock.

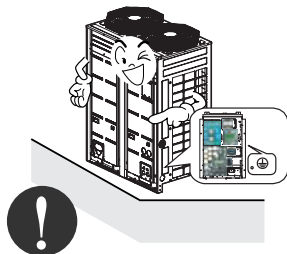

Always install a dedicated circuit and breaker.

- Improper wiring or installation may cause fire or electric shock.

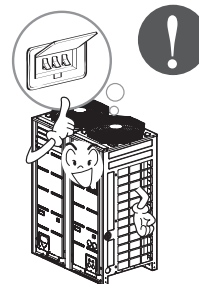

Safety Precautions

For re-installation of the installed product, always contact a dealer or an Authorized Service Center.

- There is risk of fire, electric shock, explosion, or injury.

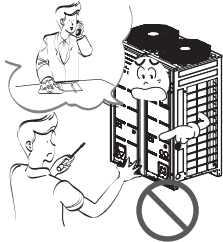

Do not install, remove, or re-install the unit by yourself (customer).

- There is risk of fire, electric shock, explosion, or injury.

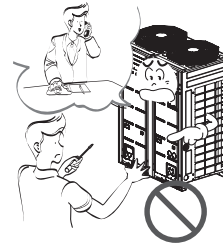

Do not store or use flammable gas or combustibles near the air conditioner.

- There is risk of fire or failure of product.

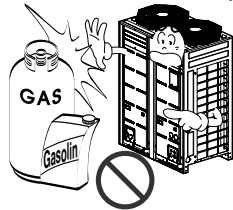

Use the correctly rated breaker or fuse.

- There is risk of fire or electric shock.

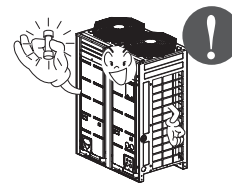

Prepare for strong wind or earthquake and install the unit at the specified place.

- Improper installation may cause the unit to topple and result in injury.



Do not install the product on a defective installation stand.

- It may cause injury, accident, or damage to the product.

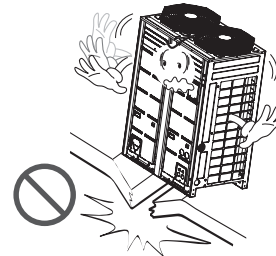

When installing and moving the air conditioner to another site, do not charge it with a different refrigerant from the refrigerant specified on the unit.

- If a different refrigerant or air is mixed with the original refrigerant, the refrigerant cycle may malfunction and the unit may be damaged.

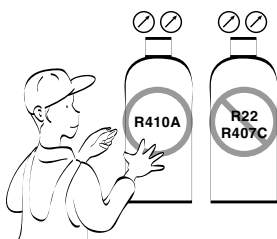

Do not reconstruct to change the settings of the protection devices.

- If the pressure switch, thermal switch, or other protection device is shorted and operated forcibly, or parts other than those specified by LGE are used, fire or explosion may result.

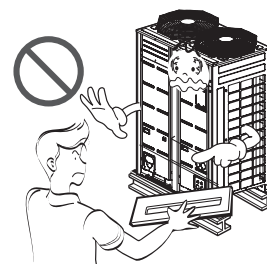

Ventilate before operating air conditioner when gas leaked out.

- It may cause explosion, fire, and burn.

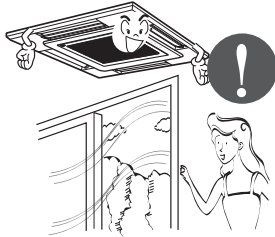

Securely install the cover of control box and the panel.

- If the cover and panel are not installed securely, dust or water may enter the outdoor unit and fire or electric shock may result.

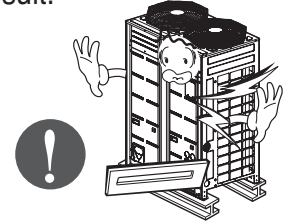

If the air conditioner is installed in a small room, measures must be taken to prevent the refrigerant concentration from exceeding the safety limit when the refrigerant leaks.

- Consult the dealer regarding the appropriate measures to prevent the safety limit from being exceeded. Should the refrigerant leak and cause the safety limit to be exceeded, hazards due to lack of oxygen in the room could result.

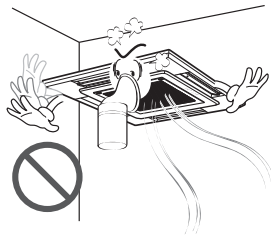

n Operation

Do not damage or use an unspecified power cord.

- There is risk of fire, electric shock, explosion, or injury.

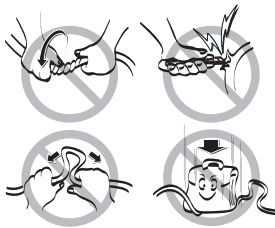

Use a dedicated outlet for this appliance.

- There is risk of fire or electrical shock.

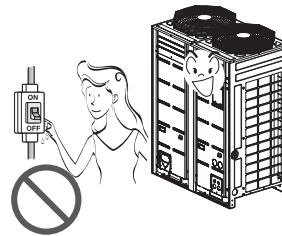

Be cautious that water could not enter the product.

- There is risk of fire, electric shock, or product damage.

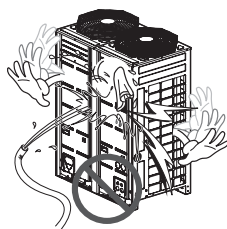

Do not touch the power switch with wet hands.

- There is risk of fire, electric shock, explosion, or injury.



Safety Precautions

When the product is soaked (flooded or submerged), contact an Authorized Service Center.

- There is risk of fire or electric shock.

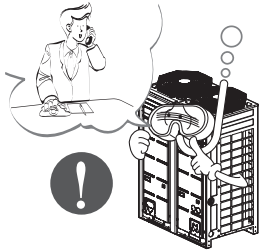

Be cautious not to touch the sharp edges when installing.

- It may cause injury.

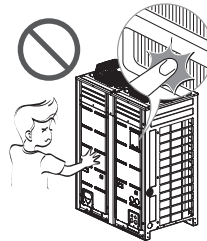

Take care to ensure that nobody could step on or fall onto the outdoor unit.

- This could result in personal injury and product damage.

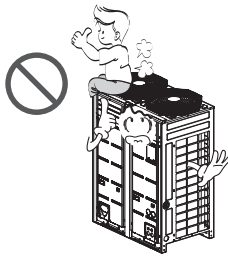

Do not open the inlet grille of the product during operation. (Do not touch the electrostatic filter, if the unit is so equipped.)

- There is risk of physical injury, electric shock, or product failure.

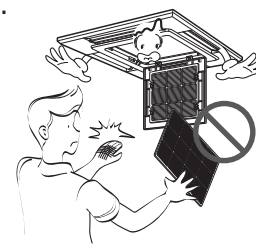

CAUTION

n Installation

Always check for gas (refrigerant) leakage after installation or repair of product.

- Low refrigerant levels may cause failure of product.

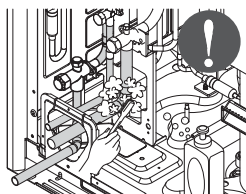

Do not install the product where the noise or hot air from the outdoor unit could damage the neighborhoods.

- It may cause a problem for your neighbors.



Keep level even when installing the product.

- To avoid vibration or water leakage.

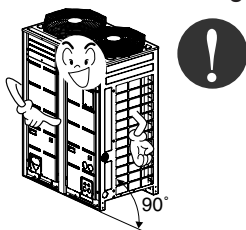

Do not install the unit where combustible gas may leak.

- If the gas leaks and accumulates around the unit, an explosion may result.

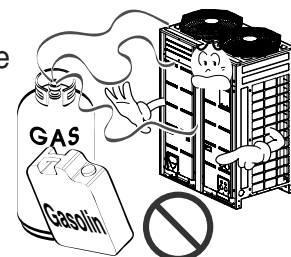

Use power cables of sufficient current carrying capacity and rating.

- Cables that are too small may leak, generate heat, and cause a fire.

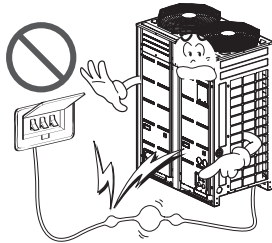

Do not use the product for special purposes, such as preserving foods, works of art, etc. It is a consumer air conditioner, not a precision refrigeration system.

- There is risk of damage or loss of property.

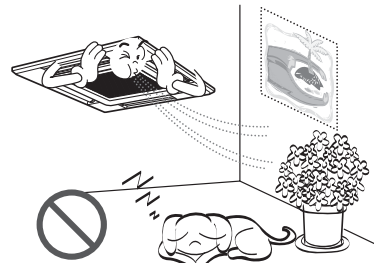

Keep the unit away from children. The heat exchanger is very sharp.

- It can cause the injury, such as cutting the finger. Also the damaged fin may result in degradation of capacity.

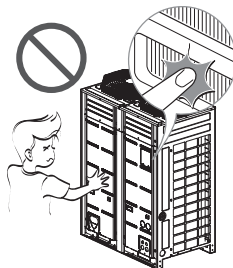

When installing the unit in a hospital, communication station, or similar place, provide sufficient protection against noise.

- The inverter equipment, private power generator, high-frequency medical equipment, or radio communication equipment may cause the air conditioner to operate erroneously, or fail to operate. On the other hand, the air conditioner may affect such equipment by creating noise that disturbs medical treatment or image broadcasting.

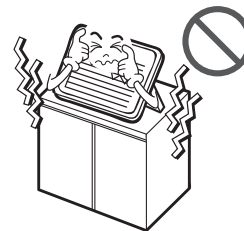

Do not install the product where it is exposed to sea wind (salt spray) directly.

- It may cause corrosion on the product. Corrosion, particularly on the condenser and evaporator fins, could cause product malfunction or inefficient operation.



n Operation

Do not use the air conditioner in special environments.

- Oil, steam, sulfuric smoke, etc. can significantly reduce the performance of the air conditioner or damage its parts.

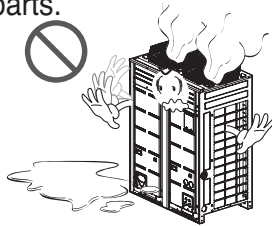

Do not block the inlet or outlet.

- It may cause failure of appliance or accident.

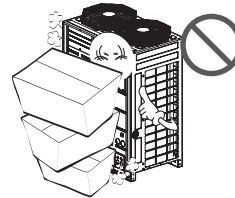

Make the connections securely so that the outside force of the cable may not be applied to the terminals.

- Inadequate connection and fastening may generate heat and cause a fire.

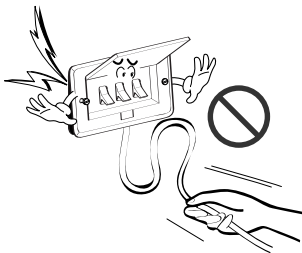

Be sure the installation area does not deteriorate with age.

- If the base collapses, the air conditioner could fall with it, causing property damage, product failure, or personal injury.



Install and insulate the drain hose to ensure that water is drained away properly based on the installation manual.

- A bad connection may cause water leakage.



Be very careful about product transportation.

- Only one person should not carry the product if it weighs more than 20 kg.
- Some products use PP bands for packaging. Do not use any PP bands for a means of transportation. It is dangerous.
- Do not touch the heat exchanger fins. Doing so may cut your fingers.
- When transporting the outdoor unit, suspending it at the specified positions on the unit base. Also support the outdoor unit at four points so that it cannot slip sideways.

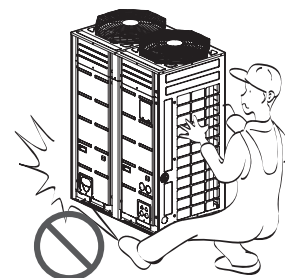

Safely dispose of the packing materials.

- Packing materials, such as nails and other metal or wooden parts, may cause stabs or other injuries.
- Tear apart and throw away plastic packaging bags so that children may not play with them. If children play with a plastic bag which was not torn apart, they face the risk of suffocation.



Do not touch any of the refrigerant piping during and after operation.

- It can cause a burn or frostbite.

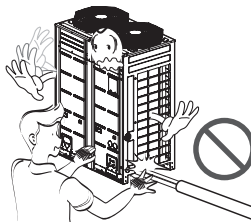

Do not directly turn off the main power switch after stopping operation.

- Wait at least 5 minutes before turning off the main power switch. Otherwise it may result in water leakage or other problems.

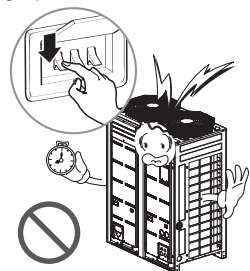

Use a firm stool or ladder when cleaning or maintaining the air conditioner.

- Be careful and avoid personal injury.

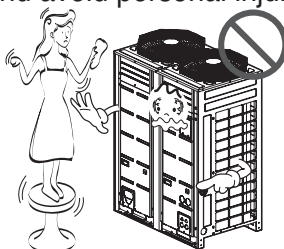

Turn on the power at least 6 hours before starting operation.

- Starting operation immediately after turning on the main power switch can result in severe damage to internal parts. Keep the power switch turned on during the operational season.

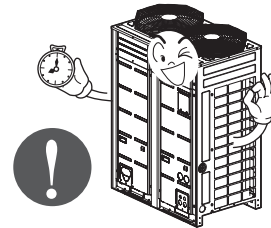

Do not operate the air conditioner with the panels or guards removed.

- Rotating, hot, or high-voltage parts can cause injuries.

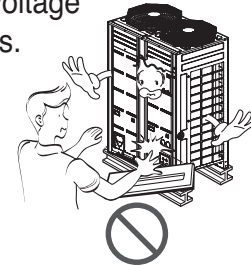

Auto-addressing should be done in condition of connecting the power of all indoor and outdoor units. Auto-addressing should also be done in case of changing the indoor unit PCB.

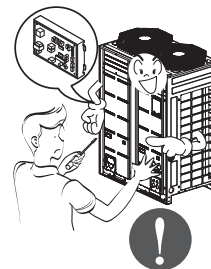

Do not insert hands or other objects through the air inlet or outlet while the air conditioner is plugged in.

- There are sharp and moving parts that could cause personal injury.



Part 1

General Information

1. Model Names	11
1.1 Indoor Unit	11
1.2 Outdoor Unit	11
2. External Appearance	13
2.1 Indoor Unit	13
2.2 Outdoor Unit	14
3. Combination of Outdoor Units	17
4. Nomenclature	19
4.1 Indoor Unit	19
4.2 Outdoor Unit	19

1. Model Names

1.1 Indoor Unit

Category	Chassis Name	Capacity(Btu/h(kW))												
		5k (1.6)	7k (2.2)	9k (2.8)	12k (3.6)	15k (4.5)	18k (5.6)	24k (7.1)	28k (8.2)	36k (10.6)	42k (12.3)	48k (14.1)	76k (22.4)	96k (28.0)
Wall Mounted (General)	SE		ARNU07GSE*2	ARNU09GSE*2	ARNU12GSE*2	ARNU15GSE*2								
	S5						ARNU18G S5*2	ARNU24G S5*2						
ART COOL	Mirror	SE	ARNU07G SE*2	ARNU09G SE*2	ARNU12G SE*2	ARNU15G SE*2								
		S8					ARNU18G S8*2	ARNU24G S8*2						
	Gallery	SF	ARNU07G SF*2	ARNU09G SF*2	ARNU12G SF*2									
Ceiling Cassette	1 Way	TU	ARNU07G GTU*2	ARNU09G GTU*2	ARNU12G GTU*2									
		TT					ARNU18G TT*2	ARNU24G TT*2						
	2 Way	TL					ARNU18G TL*2	ARNU24G TL*2						
		4 Way	TR	ARNU05 GTR*2	ARNU07G TR*2	ARNU09G TR*2	ARNU12G TR*2							
	TQ						ARNU15 GTQ*2	ARNU18G TQ*2						
	TP							ARNU24G TP*2	ARNU28G TP*2					
	TN									ARNU36G TN*2				
	TM									ARNU42G TM*2	ARNU48G TM*2			
Ceiling Concealed Duct	High Static	BH	ARNU07G BHA2	ARNU09G BHA2	ARNU12G BHA2	ARNU15G BHA2	ARNU18G BHA2	ARNU24G BHA2						
		BG							ARNU28G BGA2	ARNU36G BGA2	ARNU42G BGA2			
		BR										ARNU48G BRA2		
		B8											URNU76 GB8A2	URNU96 GB8A2
	Low Static	B1	ARNU07 GB1G2	ARNU09 GB1G2	ARNU12 GB1G2	ARNU15 GB1G2								
		B2					ARNU18 GB2G2	ARNU24 GB2G2						
	Built In	B3	ARNU07 GB3G2	ARNU09 GB3G2	ARNU12 GB3G2	ARNU15 GB3G2								
		B4					ARNU18G B4G2	ARNU24G B4G2						
Ceiling & Floor	VE		ARNU09G VEA2	ARNU12G VEA2										
Ceiling Suspended	VJ					ARNU18G VJA2	ARNU24G VJA2							
Floor Standing	With Case	CE	ARNU07G CEA2	ARNU09G CEA2	ARNU12G CEA2	ARNU15G CEA2								
		CF					ARNU18G CFA2	ARNU24G CFA2						
	Without Case	CE	ARNU07G CEU2	ARNU09G CEU2	ARNU12G CEU2	ARNU15G CEU2								
		CF					ARNU18G CFU2	ARNU24G CFU2						
Console	QA	ARNU07G QAA2	ARNU09G QAA2	ARNU12G QAA2	ARNU15G QAA2									
Fresh Air Intake Unit	BR										ARNU48G BRZ2			
	B8											URNU76 GB8Z2	URNU96 GB8Z2	
Heat Recovery Ventilator	ZE			LZ-H050GXNO LZ-H050GXHO			LZ-H080GXNO LZ-H080GXHO	LZ-H100GXNO LZ-H100GXHO						

*ART COOL- SE/S8(* R:Mirror, V:Silver, B : Blue), SF(* E:Red, V:Silver, G:Gold , 1: Kiss (Photo changeable))

*Wall Mounted- A: Basic, L:Plasma, *Ceiling Cassette- A: Basic, C:Plasma

1.2 Outdoor Unit

Power Supply	6HP	8HP	10HP	12HP	14HP	16HP	18HP	20HP
3Ø, 380 ~ 415V, 50Hz 3Ø, 380V, 60Hz	60LT3	80LT3	100LT3	120LT3	140LT3	160LT3	180LT3	200LT3

Power Supply	22HP	24HP	26HP	28HP	30HP	32HP	34HP	36HP	38HP
3Ø, 380 ~ 415V, 50Hz 3Ø, 380V, 60Hz	220LT3	240LT3	260LT3	280LT3	300LT3	320LT3	340LT3	360LT3	380LT3

Power Supply	40HP	42HP	44HP	46HP	48HP	50HP	52HP	54HP	56HP
3Ø, 380 ~ 415V, 50Hz 3Ø, 380V, 60Hz	400LT3	420LT3	440LT3	460LT3	480LT3	500LT3	520LT3	540LT3	560LT3

Power Supply	58HP	60HP	62HP	64HP	66HP	68HP	70HP	72HP	74HP
3Ø, 380 ~ 415V, 50Hz 3Ø, 380V, 60Hz	580LT3	600LT3	620LT3	640LT3	660LT3	680LT3	700LT3	720LT3	740LT3

Power Supply	76HP	78HP	80HP
3Ø, 380 ~ 415V, 50Hz 3Ø, 380V, 60Hz	760LT3	780LT3	800LT3

Heat Pump	ARUN
Cooling Only	ARUV

2. External Appearance

2.1 Indoor Unit

<p>Ceiling Cassette- 1Way ARNU07GTU*2 ARNU09GTU*2 ARNU12GTU*2 ARNU18GTT*2 ARNU24GTT*2 * A:Basic, C:Plasma</p> 	<p>Ceiling Concealed Duct - High Static ARNU07GBHA2 ARNU36GBGA2 ARNU09GBHA2 ARNU42GBGA2 ARNU12GBHA2 ARNU48GBRA2 ARNU15GBHA2 URNU76GB8A2 ARNU18GBHA2 URNU96GB8A2 ARNU24GBHA2 ARNU28GBGA2</p> 
<p>Ceiling Cassette- 4Way ARNU05GTR*2 ARNU24GTP*2 ARNU07GTR*2 ARNU28GTP*2 ARNU09GTR*2 ARNU36GTN*2 ARNU12GTR*2 ARNU42GTM*2 ARNU15GTQ*2 ARNU48GTM*2 ARNU18GTQ*2 * A:Basic, C:Plasma</p> 	<p>Wall Mounted ARNU07GSE*2 ARNU15GSE*2 ARNU09GSE*2 ARNU18GS5*2 ARNU12GSE*2 ARNU24GS5*2 * A:Basic, L:Plasma</p> 
<p>Ceiling Concealed Duct - Low Static ARNU07GB1G2 ARNU15GB1G2 ARNU09GB1G2 ARNU18GB2G2 ARNU12GB1G2 ARNU24GB2G2</p> 	<p>ART COOL Gallery ARNU07GSF*2 ARNU09GSF*2 ARNU12GSF*2 * E:Red V:Silver G:Gold 1: Kiss (Photo changeable)</p> 
<p>Ceiling Concealed Duct – Built-in ARNU07GB3G2 ARNU15GB3G2 ARNU09GB3G2 ARNU18GB4G2 ARNU12GB3G2 ARNU24GB4G2</p> 	<p>Floor Standing With case ARNU07GCEA2 ARNU15GCEA2 ARNU09GCEA2 ARNU18GCFA2 ARNU12GCEA2 ARNU24GCFA2</p> <p>Without case ARNU07GCEU2 ARNU15GCEU2 ARNU09GCEU2 ARNU18GCFU2 ARNU12GCEU2 ARNU24GCFU2</p> 
<p>ART COOL Mirror ARNU07GSE*2 *R:Mirror ARNU09GSE*2 V:Silver ARNU12GSE*2 B:Blue ARNU15GSE*2 ARNU18GS8*2 ARNU24GS8*2</p> 	<p>Console ARNU07GQAA2 ARNU09GQAA2 ARNU12GQAA2 ARNU15GQAA2</p> 
<p>Ceiling & Floor ARNU09GVEA2 ARNU12GVEA2</p> <p>Ceiling Suspended ARNU18GVJA2 ARNU24GVJA2</p> 	<p>Fresh Air Intake Unit ARNU48GBRZ2 URNU76GB8Z2 URNU96GB8Z2</p> 
<p>Ceiling Cassette -2Way ARNU18GTL*2 ARNU24GTL*2 * A:Basic, C:Plasma</p> 	<p>Heat Recovery Ventilator LZ-H050GXN0 LZ-H050GXH0 LZ-H080GXN0 LZ-H080GXH0 LZ-H100GXN0 LZ-H100GXH0</p> 









※ These are model names of the basic function.







2.2 Outdoor Unit

2.2.1 Heat Pump

CHASSIS	Model Name	Model
UX2	ARUN80LT3 ARUN100LT3 ARUN120LT3	
UX3	ARUN140LT3 ARUN160LT3 ARUN180LT3 ARUN200LT3	
UX2 UX2	ARUN220LT3 ARUN240LT3	
UX3 UX2	ARUN260LT3 ARUN280LT3	
UX3 UX3	ARUN300LT3 ARUN360LT3 ARUN320LT3 ARUN380LT3 ARUN340LT3 ARUN400LT3	
UX3 UX3 UX2	ARUN420LT3 ARUN440LT3	
UX3 UX3 UX3	ARUN460LT3 ARUN540LT3 ARUN480LT3 ARUN560LT3 ARUN500LT3 ARUN580LT3 ARUN520LT3 ARUN600LT3	
UX3 UX3 UX3 UX3	ARUN620LT3 ARUN720LT3 ARUN640LT3 ARUN740LT3 ARUN660LT3 ARUN760LT3 ARUN680LT3 ARUN780LT3 ARUN700LT3 ARUN800LT3	

2.2.2 Cooling Only

CHASSIS	Model Name	Model
UX1	ARUV60LT3 ARUV80LT3	
UX2	ARUV100LT3 ARUV120LT3 ARUV140LT3	
UX3	ARUV160LT3 ARUV180LT3 ARUV200LT3	
UX2 UX2	ARUV220LT3 ARUV240LT3 ARUV260LT3 ARUV280LT3	
UX3 UX2	ARUV300LT3 ARUV320LT3 ARUV340LT3	
UX3 UX3	ARUV360LT3 ARUV380LT3 ARUV400LT3	
UX2 UX2 UX2	ARUV420LT3	
UX3 UX2 UX2	ARUV440LT3 ARUV460LT3 ARUV480LT3	

CHASSIS	Model Name	Model
UX3 UX3 UX2	ARUV500LT3 ARUV520LT3 ARUV540LT3	
UX3 UX3 UX3	ARUV560LT3 ARUV580LT3 ARUV600LT3	
UX3 UX2 UX2 UX2	ARUV620LT3	
UX3 UX3 UX2 UX2	ARUV640LT3 ARUV660LT3 ARUV680LT3	
UX3 UX3 UX3 UX2	ARUV700LT3 ARUV720LT3 ARUV740LT3	
UX3 UX3 UX3 UX3	ARUV760LT3 ARUV780LT3 ARUV800LT3	

3. Combination of Outdoor Units

3.1 Heat Pump

System Capacity	Number of Units	Module(HP)						
		8	10	12	14	16	18	20
ARUN80LT3	1	1						
ARUN100LT3	1		1					
ARUN120LT3	1			1				
ARUN140LT3	1				1			
ARUN160LT3	1					1		
ARUN180LT3	1						1	
ARUN200LT3	1							1
ARUN220LT3	2		1	1				
ARUN240LT3	2			2				
ARUN260LT3	2			1	1			
ARUN280LT3	2			1		1		
ARUN300LT3	2				1	1		
ARUN320LT3	2					2		
ARUN340LT3	2					1	1	
ARUN360LT3	2					1		1
ARUN380LT3	2						1	1
ARUN400LT3	2							2
ARUN420LT3	3			1	1	1		
ARUN440LT3	3			1		2		
ARUN460LT3	3				1	2		
ARUN480LT3	3					3		
ARUN500LT3	3					2	1	
ARUN520LT3	3					2		1
ARUN540LT3	3				1			2
ARUN560LT3	3					1		2
ARUN580LT3	3						1	2
ARUN600LT3	3							3
ARUN620LT3	4				1	3		
ARUN640LT3	4					4		
ARUN660LT3	4					3	1	
ARUN680LT3	4					2	2	
ARUN700LT3	4					2	1	1
ARUN720LT3	4					2		2
ARUN740LT3	4					1	1	2
ARUN760LT3	4					1		3
ARUN780LT3	4						1	3
ARUN800LT3	4							4

3.2 Cooling Only

System Capacity	Number of Units	Module(HP)							
		6	8	10	12	14	16	18	20
ARUV60LT3	1	1							
ARUV80LT3	1		1						
ARUV100LT3	1			1					
ARUV120LT3	1				1				
ARUV140LT3	1					1			
ARUV160LT3	1						1		
ARUV180LT3	1							1	
ARUV200LT3	1								1
ARUV220LT3	2			1	1				
ARUV240LT3	2			1		1			
ARUV260LT3	2				1	1			
ARUV280LT3	2					2			
ARUV300LT3	2					1	1		
ARUV320LT3	2					1		1	
ARUV340LT3	2					1			1
ARUV360LT3	2						1		1
ARUV380LT3	2							1	1
ARUV400LT3	2								2
ARUV420LT3	3					3			
ARUV440LT3	3					2	1		
ARUV460LT3	3					2		1	
ARUV480LT3	3					2			1
ARUV500LT3	3					1	1		1
ARUV520LT3	3					1		1	1
ARUV540LT3	3					1			2
ARUV560LT3	3						1		2
ARUV580LT3	3							1	2
ARUV600LT3	3								3
ARUV620LT3	4					3			1
ARUV640LT3	4					2	1		1
ARUV660LT3	4					2		1	1
ARUV680LT3	4					2			2
ARUV700LT3	4					1	1		2
ARUV720LT3	4					1		1	2
ARUV740LT3	4					1			3
ARUV760LT3	4						1		3
ARUV780LT3	4							1	3
ARUV800LT3	4								4

4. Nomenclature

4.1 Indoor Unit

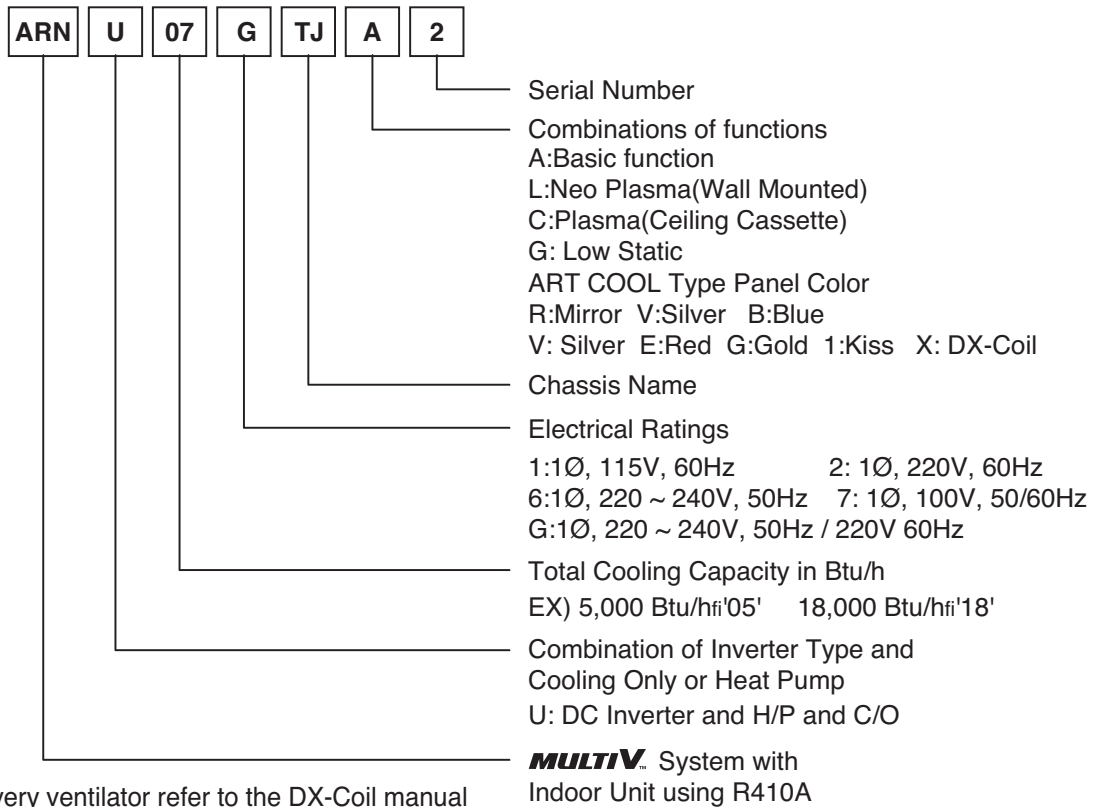

※ Heat recovery ventilator refer to the DX-Coil manual

4.2 Outdoor Unit

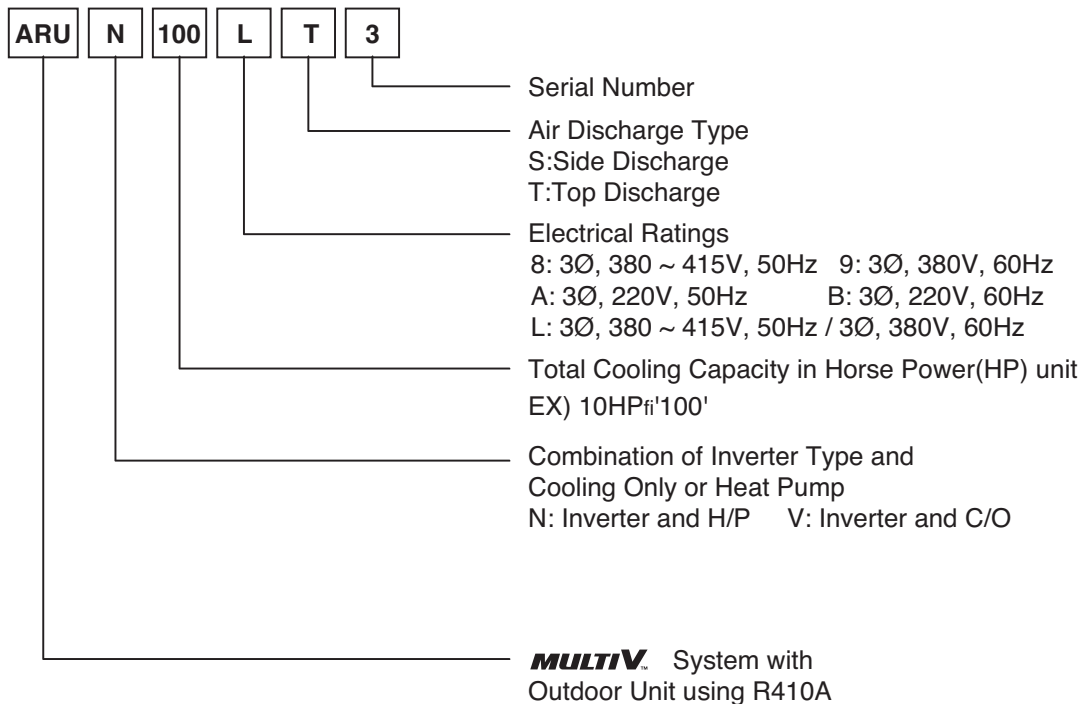

Part 2

Outdoor Units

ARUV/ARUN Series

• Function	22
-------------------------	-----------

Function

1. Basic control	23
1.1 Normal operation	23
1.2 Compressor control.....	23
1.3 Master and slave unit's EEV control	24
2. Special control	25
2.1 Oil return control	25
2.2 Defrost control.....	27
2.3 Partial Defrost	
2.4 Stop operation.....	
2.5 Oil equalizing control.....	28
3. Protection control	30
3.1 Pressure protection control	30
3.2 Discharge temperature control.....	31
3.3 Inverter protection control	31
3.4 Phase detection	32
3.5 Pressure switch.....	32
4. Other control	33
4.1 Initial setup.....	33
4.2 Emergency operation.....	35
4.3 Sensor checking function	36
4.4 Refrigerant Auto Charging	39
4.5 Refrigerant Checking Function	41
4.6 IDU EEV Abnormal Checking Function	43
4.7 Integrated Test Runing Function_Cooling Mode	44
4.8 Integrated Test Runing Function_Heating Mode.....	45
4.8 Auto Back Up Function_Inverter compressor	44
4.9 Pump Down	47
4.10 Pump Out.....	48
4.11 Auto Back Up Function_Inverter compressor.....	50
4.12 Auto Back Up Function_constant speed compressor	51
4.13 Night Low Noise Function	52
4.14 Vacuum Mode	53
4.15 Static pressure compensation mode.....	53
4.16 Black Box Function	54

1. Basic control

1.1 Normal operation

Actuator	Cooling operation	Heating operation	Stop state
Compressor	Fuzzy control	Fuzzy control	stop
Fan	Fuzzy control	Fuzzy control	stop
Main EEV	Full open	Fuzzy control	Min. pulse
Subcooling EEV	Fuzzy control	<ul style="list-style-type: none"> Normal : minimum pulse Avoiding control of high discharge temperature 	Min. pulse
Indoor Unit EEV	Superheat fuzzy control	Subcooling fuzzy control	Min. pulse

Note : Heating operation is not functional at an outdoor air temperature of 27°C or more.
 Cooling operation is not functional at an outdoor air temperature of 2°C or less with indoor unit combination of 10% or less

1.2 Compressor control

Fuzzy control : Maintain evaporating temperature(Te) to be constant on cooling mode and condensing temperature(Tc) on heating mode by Fuzzy control to ensure the stable system performance.

(Tc:47 ~51°C, Te:2 ~ 5°C)

(1) Cooling mode

Te can be set by initial dip switch setting. (Normal mode, capacity up mode, and energy save mode)

(2) Heating mode

Tc can be set by initial dip switch setting. (Normal mode, capacity up mode, and energy save mode)

Note: By setting dip switch, Te and Tc are decided simultaneously.

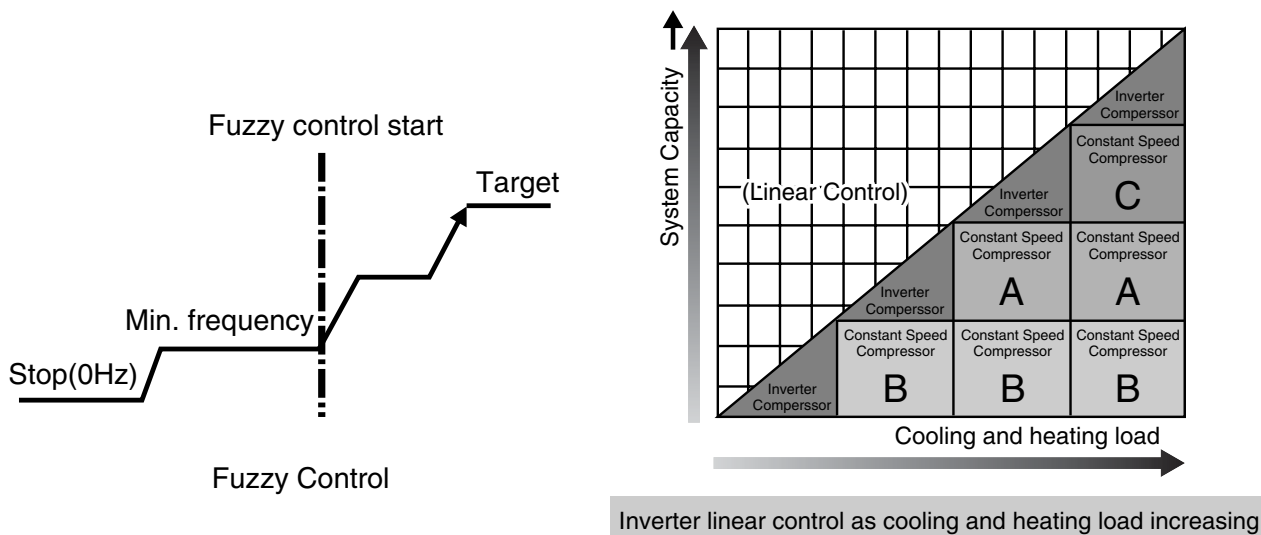

1.3 Master and slave Unit's EEV control

(1) Main EEV control

Main EEV operates with fuzzy control rules to keep the degree of super Heat(Superheat) (about 3°C) at the evaporator outlet stable during heating mode

The degree of Superheat = $T_{\text{suction}} - T_{\text{evaporation}}$

T_{suction} : temperature at suction pipe sensor(°C)

$T_{\text{evaporation}}$: evaporation temperature equivalent to low pressure(°C)

(2) Subcooling EEV control(about 15°C)

Subcooling EEV works with fuzzy rules to keep the degree of Subcool at the outlet of subcooler during cooling mode

The degree of Subcool = $T_{\text{condensation}} - T_{\text{liquid}}$

T_{liquid} : temperature at outlet of subcooler(°C)

$T_{\text{condensation}}$: condensation temperature equivalent to high pressure(°C)

(3) Avoiding excessive high discharge temperature : when main EEV opens some given opening (R22 : 1000pls, R410A : 800 pls) and discharge temperature is above 85°C in heating operation, subcooling EEV may control the "subcooling out temperature-evaporating temperature" to be some given difference.

2. Special control

2.1 Oil return control

2.1.1 Oil return control on cooling mode

Oil return operation recovers oil amount in compressor by collecting oil accumulated in pipe. Each cycle component operates as shown on the below table during oil return operation.

Outdoor Unit

Component	Starting	Running	Ending
Inv Compressor	30Hz	Setting Value	30Hz
Constant Speed Compressor	OFF	ON	OFF
FAN	Normal control	Normal control	Normal control
Main EEV	Max. pulse	Max. pulse	Max. pulse
Subcooling EEV	Normal control	Main. pluse	100 pulse
4way valve	OFF	OFF	OFF
Hot gas bypass valve	Normal control	Normal control	Normal control

Indoor Unit

Component	Starting	Running	Ending
Fan	Normal control	OFF	Normal control
Thermo on unit EEV	Normal control	1200 pulse	Normal control
Thermo off unit EEV	40 pulse	40 pulse	40 pulse
Oil return signal	OFF	ON	OFF

- Oil return operation time : 3 min for running step
- Starting condition:every 8 hours operate
- Oil return process ends if compressor protection control starts

2.1.2 Oil return control on heating mode

Outdoor Unit

Component	Starting	Running	Ending
Inv Compressor	30Hz	Setting Value	30Hz
Constant Speed Compressor	OFF	ON	OFF
FAN	Normal control	Normal control	Normal control
Main EEV	Max. pulse	Max. pulse	Max. pulse
Subcooling EEV	Normal control	Min. pulse	100 pulse
4way valve	ON	OFF	ON
Hot gas bypass valve	Normal control	Normal control	Normal control

Indoor Unit

Component	Starting	Running	Ending
Fan	Normal control	OFF	Normal control
Thermo on unit EEV	Normal control	400~800 pulse	Normal control
Thermo off unit EEV	80~130 pulse	400~800 pulse	80~130 pulse

- Oil return operation time : 3 min for running step
- Starting condition:same as cooling mode
- Oil return process ends if compressor protection control starts

2.2 Defrost

Defrost operation eliminates ice accumulated on heat exchanger, recovering performance of heat exchanger. Each cycle component operates as following table during defrost operation.

Outdoor Unit

Component	Starting	Running	Ending
Inv Compressor	30Hz	Setting Value	30Hz
Constant Speed Compressor	OFF	ON	OFF
FAN	Stop	High pressure control	Normal control
Main EEV	Normal control	Max. pulse	Normal control
Subcooling EEV	Normal control	Min. pulse	Normal control
4way valve	On → OFF	OFF	ON
Hot gas bypass valve	Normal control	Normal control	Normal control

Indoor Unit

Component	Starting	Running	Ending
Fan	OFF	OFF	OFF
Thermo on unit EEV	Normal control	400~800 pulse	Normal control

■ Ending condition

- 1) All heat exchanger pipe temperature are above setting temperature for 30 sec.
- 2) The running time of defrost operation is over 30% of the total heating time
- 3) If compressor protection control starts by high discharge temperature of compressor etc.

2.3 Partial Defrost

Partial defrost operation divides heat exchanger with upper and parts that gives a chance to make the defrost separately in order to proceed the heating performance continuously. Each cycle component operates as following table during partial defrost operation.

Outdoor Unit

Component	Starting	Running	Ending
Inv Compressor	Normal control	Setting Value	Normal control
Constant Speed Compressor	Normal control	ON	Normal control
FAN	Normal control	Low pressure control	Normal control
Main EEV	Normal control	Normal control	Normal control
Subcooling EEV	Normal control	Normal control	Normal control
4way valve	ON	ON	ON
Hot gas bypass valve(Upper,Low)	OFF	Upper ON, Low OFF → Upper OFF, Low ON	OFF

Indoor Unit

Component	ON(Setting)	ON(Low)	ON(Setting)
Fan	Normal control	Normal control	Normal control
Thermo on unit EEV	Normal control	400~800 pulse	Normal control

■ Ending condition

- 1) Upper defrost ending condition over setting temperature.
- 2) Low defrost ending condition over setting temperature.
- 3) Max. 12 minutes

2.4 Stopping operation

2.4.1 Stopping operation on cooling mode

Component	Operation	Note
Inv Compressor	OFF	-
Constant Speed Compressor	OFF	-
FAN	Stop	-
Main EEV	50 pulse	-
Subcooling EEV	35 pulse	Stop(Min. pulse)
4way valve	OFF	-
Hot gas bypass valve	OFF	OFF after 15 min.

2.4.2 Stopping operation on heating mode

Component	Operation	Note
Inv Compressor	OFF	-
Constant Speed Compressor	OFF	-
FAN	Stop	-
Main EEV	50 pulse	-
Subcooling EEV	35 pulse	Stop(Min. pulse)
4way valve	ON	OFF over 30°C air temperature
Hot gas bypass valve	ON	OFF After 15 min.

2.5 Oil equalizing control

This function prevent oil unbalance between inverter. compressor. and constant speed compressor.

Compressor discharge temperature - Compressor oil temperature \geq Standard oil temperature
 Compressor oil temperature : Compressor oil balance temperature where the end of capi.

3. Protection control

3.1 Pressure protection control

3.1.1 Pressure control on cooling mode

■ High pressure control

Pressure Range	Compressor	Fan
$P_d \geq 4003 \text{ kPa}$	Stop	Stop
$P_d > 3807 \text{ kPa}$	-5Hz/ 4sec.	+100RPM/4sec.
$P_d \geq 3644 \text{ kPa}$	Frequency holding	Normal control
$P_d < 3644 \text{ kPa}$	Normal control	

■ Low pressure control

Pressure Range	Compressor	Fan
$P_s \leq 150\text{kPa}$, 1 minute later operation	Stop	Stop
$P_s \leq 346\text{kPa}$, 1 minute before operation	-5Hz/4s	-100RPM/ 4sec.
$P_s \leq 399\text{kPa}$	Normal control	Frequency holding

※ Frequency holding : frequency (or RPM) is not increasing (can decrease)

3.1.2 Pressure control on heating mode

■ High pressure control

Pressure Range	Compressor	Fan
$P_d \geq 4003 \text{ kPa}$	Stop	Stop
$P_d > 3415 \text{ kPa}$	-5Hz/4sec.	-50RPM/ 4sec.
$P_d \geq 3317 \text{ kPa}$	Normal control	Frequency holding
$P_d < 3317 \text{ kPa}$	Normal control	$P_d < 3284 \text{ N/control}$

■ Low pressure control

Pressure Range	Compressor	Fan
$P_s \leq 150\text{kPa}$, 1 minute later operation	Stop	Stop
$P_s \leq 150\text{kPa}$, 1 minute before operation	-5Hz/4s	+100RPM/4s
$P_s \geq 163 \text{ kPa}$	Normal control	Normal control

※ Frequency holding : frequency (or RPM) is not increasing (can decrease)

3.2 Discharge temperature control

■ Outdoor unit control

Temperature range	Compressor	Sub cooling EEV	IDU EEV
Tdis >110C	Off	SC,SH decrease control	SH decrease control
Tdis >108C	-5Hz/10sec.	SC,SH decrease control	SH decrease control
Tdis >100C	Normal control	SC,SH decrease control	SH decrease control

SC : Sub Cooling, SH : Super Heating

3.3 Inverter protection control

	Normal Operation	Frequency Down	System Stop
AC Input Current	20A or less	20A or more	22A or more
Compressor Current	24A or less	24A or more	30A or more

* AC input current is input current of inverter compressor except constant current (current pass through noise filter)

3.4 Phase detection

- When the product is reversed or missed wiring installation(Power line : R, S, T, N), it isn't defect or operate for protection of product function and constant speed compressor.

Reversed Phase	R,S,T	Single	M		
			541		
		Series	M	S1	S1
			541	542	542
			M+S1(at the same time)	M+S2(at the same time)	M+S3(at the same time)
			542	543	543
			M+S1+S2(at the same time)		
543					
When N phase and other phase(R,S,T) are reversed phase, main PCB of ODU is damaged.					
Missed Phase	R,T	Single	M		
			501		
		Series	M	S1	S2
			501	502	503
			M+S1(at the same time)	M+S2(at the same time)	M+S3(at the same time)
			502	503	503
			M+S1+S2(at the same time)		
	503				
	S	Single	M		
			231		
		Series	M	S1	S2
			231	232	233
			M+S1(at the same time)	M+S2(at the same time)	M+S3(at the same time)
			232	233	233
M+S1+S2(at the same time)					
233					
When N phase is missed phase, main PCB of ODU display CH74.					

3.5 Pressure switch

- Main has pressure sensing switch in series between compressor and power relay.
- The state of pressure sensing switch is normally on. It has small electric current from 220V AC. Never touch the connecting terminal with hand nor short two wires directly.

4. Other control

4.1 Initial setup

There are 4 initial setup steps before running.
All DIP switch setting must be completed before initial setup.

- 1) Step 1 : factory setting value display
Factory setting value is displayed in 7 segment on PCB for 24sec.
All dip switches must be set properly before step 1.

Power is on	
Master model code is displayed (3sec)	18
Slave1 model code is displayed (3sec)	18
Slave2 model code is displayed (3sec)	18
Total capacity including sub units is displayed (2sec)	60
Heat pump : Display 2 is default value Cooling only : no display	2
Factory setting(25 is normal)	25
Model type	150

2) Step 2 : Communication check

- If all model code is displayed in 7 segment including all Slave unit, communication between outdoor units is normal.
- If 104* is displayed in 7-segment, check communication wires between outdoor units and Dip switch setting.

3) Step 3 : PCB error check

- After 40 sec, error check begins.

■ Master/ Slave unit

- All errors of units including Slave units are displayed in 7 segment.
- If communication between main PCB and inverter PCB isn't normal, 52* is displayed in 7-segment
- If communication between main PCB and fan PCB isn't normal, 105* is displayed in 7-segment.
- If error is displayed, check corresponding wires.

4) Step 4 : Auto addressing of indoor units

- Auto addressing begins when address(red) button in Main PCB is pressed for 6 sec.
- During auto addressing, 7 segment on main PCB displays "88"
- After auto addressing, the number of indoor units is displayed in 7 segment for 30 sec. The address of each indoor unit is displayed on each wired remote controller.

Push address(red) button for 6 sec.

Heat pump

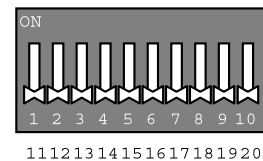
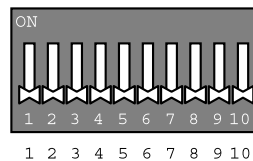

Cooling only

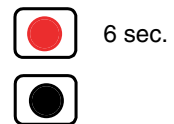
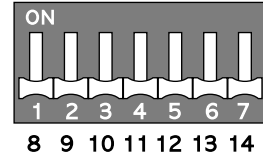
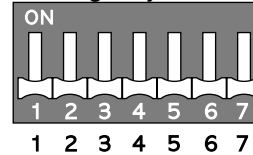

Auto address starts



Auto address is in progress (max. 15 min.)



The number of indoor units is displayed for 30 sec.



(35 indoor units found)

Auto address process is finished.
Every indoor unit displays its address on wired remote controller and the 7 segment of main PCB is off.



4.2 Emergency operation

- If a compressor is out of order, the system can be run except the defective compressor by backup function.

■ Automatic emergency operation(automatic back up function)

If outdoor unit detect comp defect during operation,, automatic back up mode is set.

- 1) Inverter compressor automatic emergency operation.
- 2) Constant compressor automatic emergency operation.

■ Manual emergency operation(Manual back up function)

- 1) Check which compressor is broken.(refer to °∞Trouble Shooting Guide°±)
- 2) Turn off the power.
- 3) Set the dip S/W of defective outdoor unit.
 - Inverter compressor defect : dip S/W No.3
 - Unit defect : dip S/W No.4
- 4) Turn on the power.

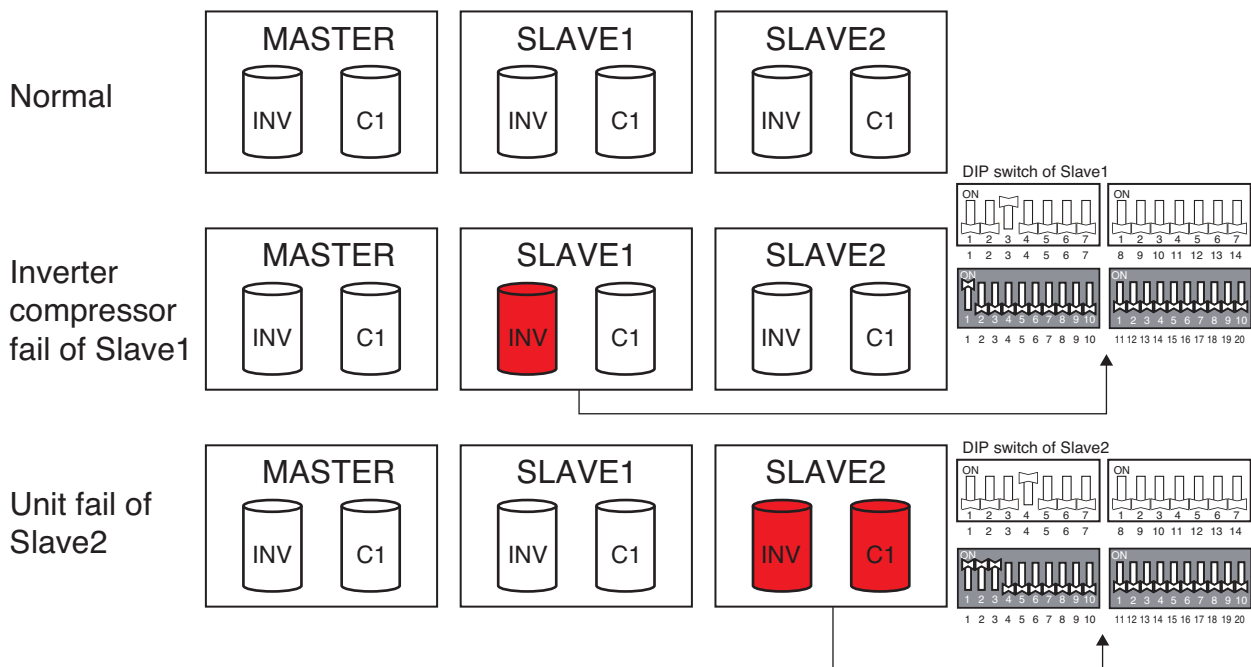

CAUTION

Emergency operation with inverter compressor failure should not last 48 hours. → It causes other compressor failure.

During the emergency operation, cooling/heating capacity may be lower.

4.3 Sensor checking function Note 1)

- If you set the Dip switch when power is on, the changed setting will not be applied immediately. The changed setting will be enabled only when Power is reset or by pressing Reset button.

DIP Switch Settings

SVC PCB (Heat pump)

Main PCB (Cooling only)

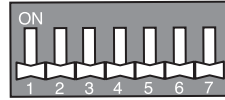
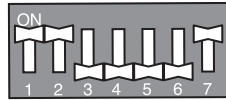
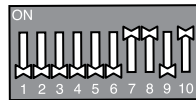
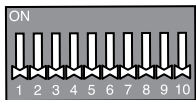

- **Setting1**
(Refrigerant Auto Recharge)

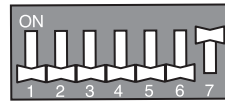
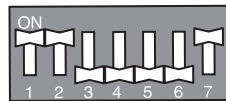
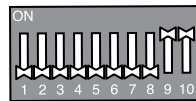
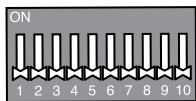

- **Setting2**
(Refrigerant Quantity Auto Decide)

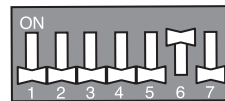
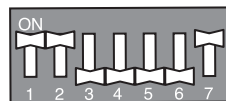
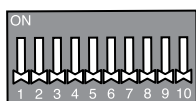

- **Setting3**
(Indoor EEV malfunction check - cooling)

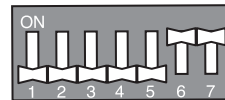
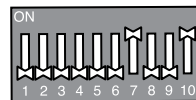
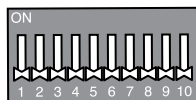

- **Setting4**
(Indoor EEV malfunction check - heating)

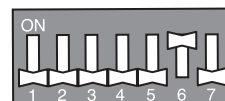
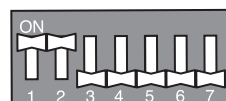
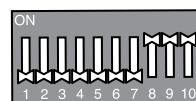
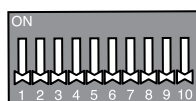

- **Setting5**
(Integrated Test Run - cooling)

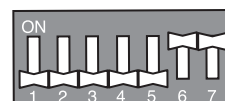
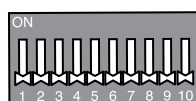

- **Setting6**
(Integrated Test Run - heating)

Warning : Please reset SVC/Main PCB before starting this function

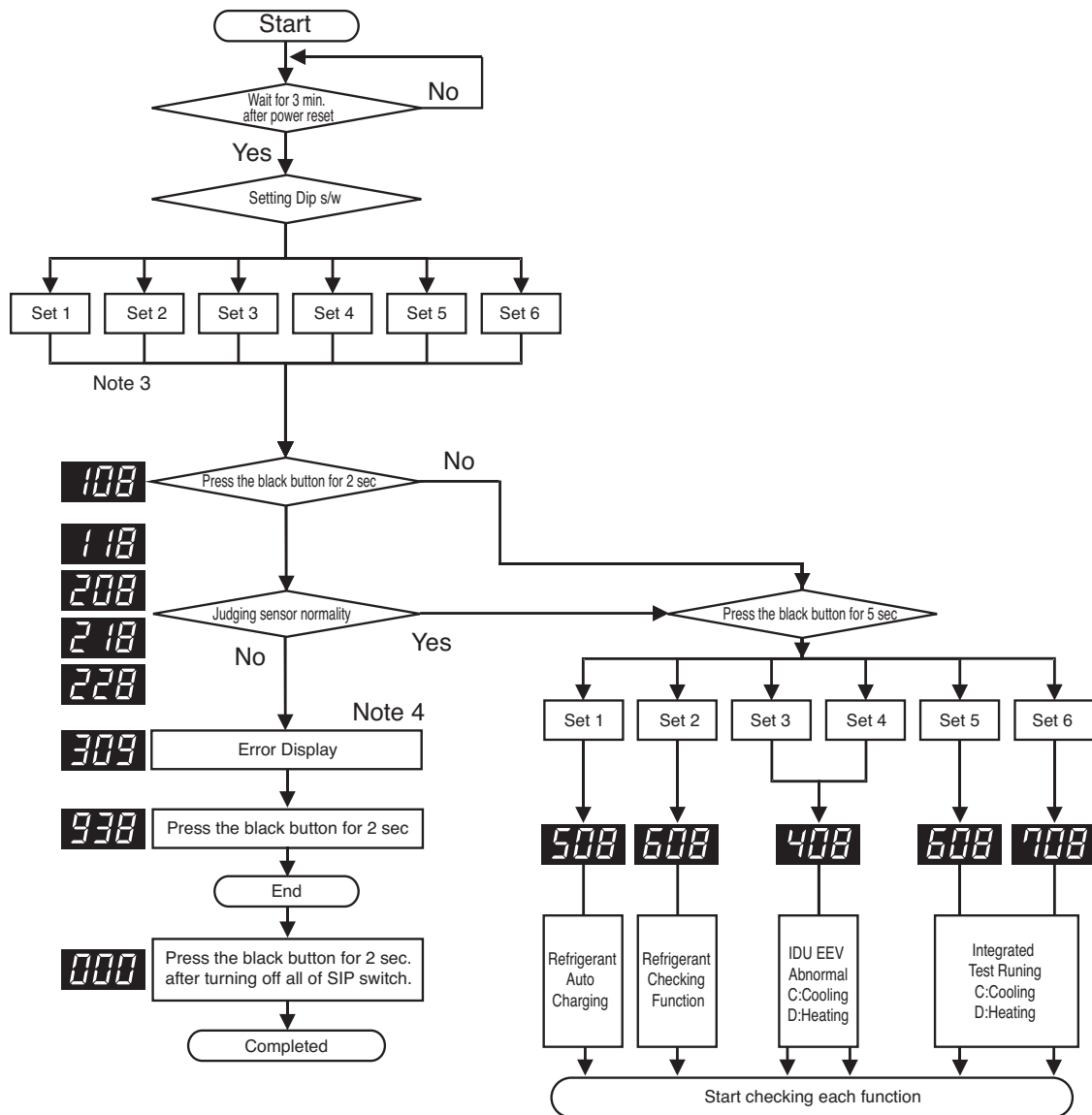

Note

1. Sensor checking function is used with refrigerant checking and refrigerant auto charging.

	UX1	UX2(1 Comp)	UX2	UX3 (2 Comp)	UX3
Heat Pump	-	9	11	11	13
Cooling Only	5	5	6	6	7

2. Check abnormal sensor

3. It is displayed at the LED on the main PCB at each step.

4. Reference the sensor error in next page.



CAUTION

1. Confirm auto addressing has been performed (Check installed number of IDU).

2. The error can be displayed even if the sensor is normal according to installation and temperature condition. If error occurs, check the sensor and judge abnormality.

■ Sensor Check Error Code Display

In case error occurs during sensor checking process.

Following contents are displayed one after the other on the main PCB of master outdoor unit.

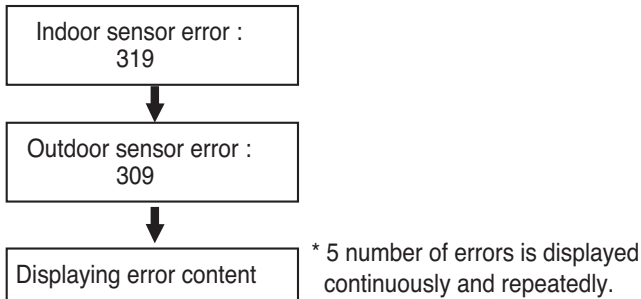

Displaying error content

■ Indoor unit error display

1. 1st and 2nd number represents indoor unit number.
2. Last digit show represents sensor.

- 1: Pipe inlet temperature sensor
- 2: Pipe outlet temperature sensor
- 3: Air temperature sensor

■ Displaying outdoor unit error

1. 1st and 2nd number represents error content(code).
2. Last digit show represents outdoor unit number.

- 1 : Master
- 2 : Slave 1
- 3 : Slave 2
- 4 : Slave 3

Table 1. ODU Sensor Error Code

No.	Sensor type
1	Outdoor Air Temperature
2	Heat Exchanger Temperature
3	Partition Heat Exchanger Temperature(Upper)
4	Partition Heat Exchanger Temperature(Low)
5	Liquid Pipe Temperature
6	SC pipe out
7	Suction Temperature
8	Inverter Comp. Discharge Temperature
9	Constant Comp.1 Discharge Temperature
10	Constant Comp.2 Discharge Temperature
11	High Pressure
12	Low Pressure
14	IPM temperature
15	INV. Oil equalizing Temperature
16	Constant Comp.1 Oil equalizing Temperature
17	Constant Comp.2 Oil equalizing Temperature

Table 2. IDU Sensor Error Code

No.	Sensor type
1	Pipe In Temperature
2	Pipe Out Temperature
3	Indoore Air Temperature

ex) Indoor unit No. 2 pipe inlet temperature sensor error



ex) Outdoor master unit liquid pipe temperature sensor error



ex) IDU No.2 pipe inlet temperature sensor error and master ODU suction temperature sensor, slave 3 high pressure sensor error

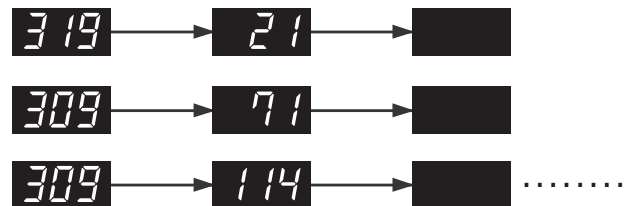

Caution

1. Up to 5 number of errors is displayed continuously and repeatedly. In case 5 number of errors occurs, again perform sensor checking after solving errors.
2. IDU in which error occurred operates air circulation mode.

4.4 Refrigerant Auto Charging (Set 1)

This function charges appropriate amount of refrigerant automatically through cycle operation. It can be used when refrigerant amount isn't certain because of SVC and leakage.

※ Refrigerant charging time is depending on charging amount. (Charging time : About 3min/Kg)

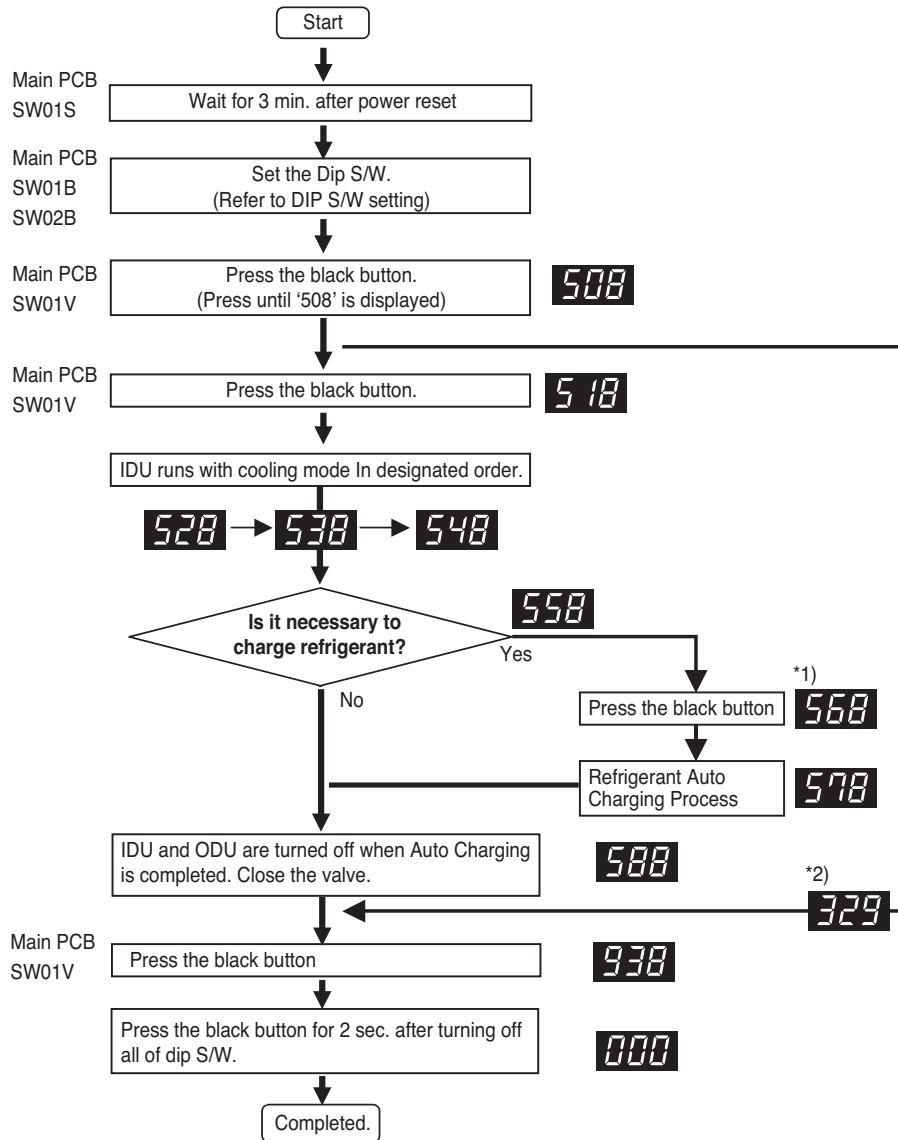

DIP Switch Settings

SVC PCB (Heat pump)

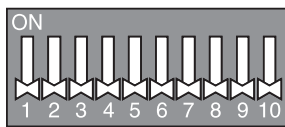

1 2 3 4 5 6 7 8 9 10

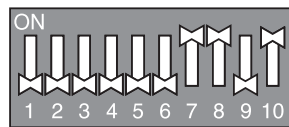

11 12 13 14 15 16 17 18 19 20

Main PCB (Cooling only)

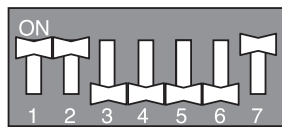

1 2 3 4 5 6 7

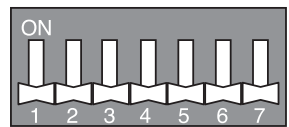

8 9 10 11 12 13 14

Warning : Please reset SVC/Main PCB before starting this function

Note

1. After installing the refrigerant charging device, **568** as shown in figure, open the valve
2. In case air temperature is out of guaranteed temperature, it may end without performing Auto charging
3. Refrigerant charging Time may change according to the charging amount. (Abt. 1.5min/lb)

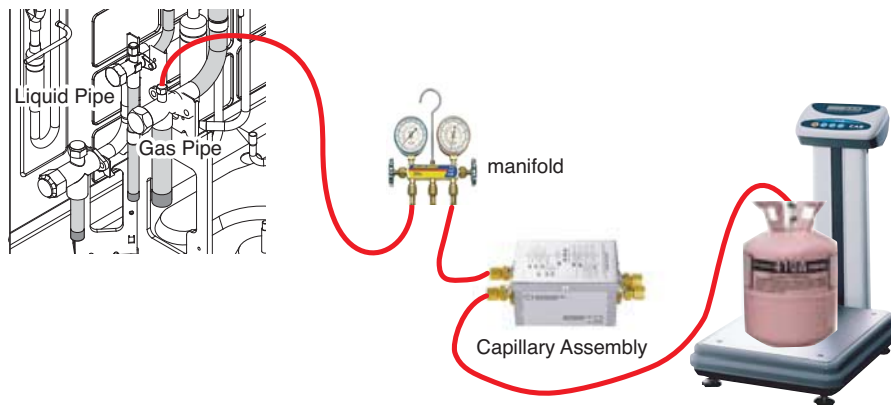

Procedure

1. Arrange manifold, capillary assembly, refrigerant vessel and scale
2. Connect manifold to the gas pipe service valve of ODU as shown in the figure.
3. Connect manifold and Capillary tube.
Use designated capillary assembly only.
If designated capillary assembly isn't used, the system may get damaged.
4. Connect capillary and refrigerant vessel.
5. Purge hose and manifold.
6. After **568** is displayed, open the valve and charge the refrigerant

■ Error contents about auto refrigerant charging function

1. **329** : Temperature Range Error (In case that IDU or ODU is out of range)
2. **339** : Low Pressure Descent Error (In case the system runs at low pressure limit for over 10 minutes)
3. **349** : Judging rapid refrigerant inflow (In case the liquid refrigerant flows in because of not using designated Capillary Assembly)
4. **359** : Instability Error(In case the high/low pressure target doesn't get satisfied for some time after the starting operation)

! CAUTION

1. Guaranteed temperature range (Error will occur if temperature is out of range)
IDU : 20~32°C
ODU : 0~43°C
2. For refrigerant charging, use designated device only. (Capillary Assem Set)
3. Set the IDU wired remote controller temperature sensing mode as IDU
4. Be careful that IDU should not be thermo off.

4.5 Refrigerant Checking Function (Set 2)

This function judges refrigerant leakage and overcharging. It can be used with refrigerant auto charging function.

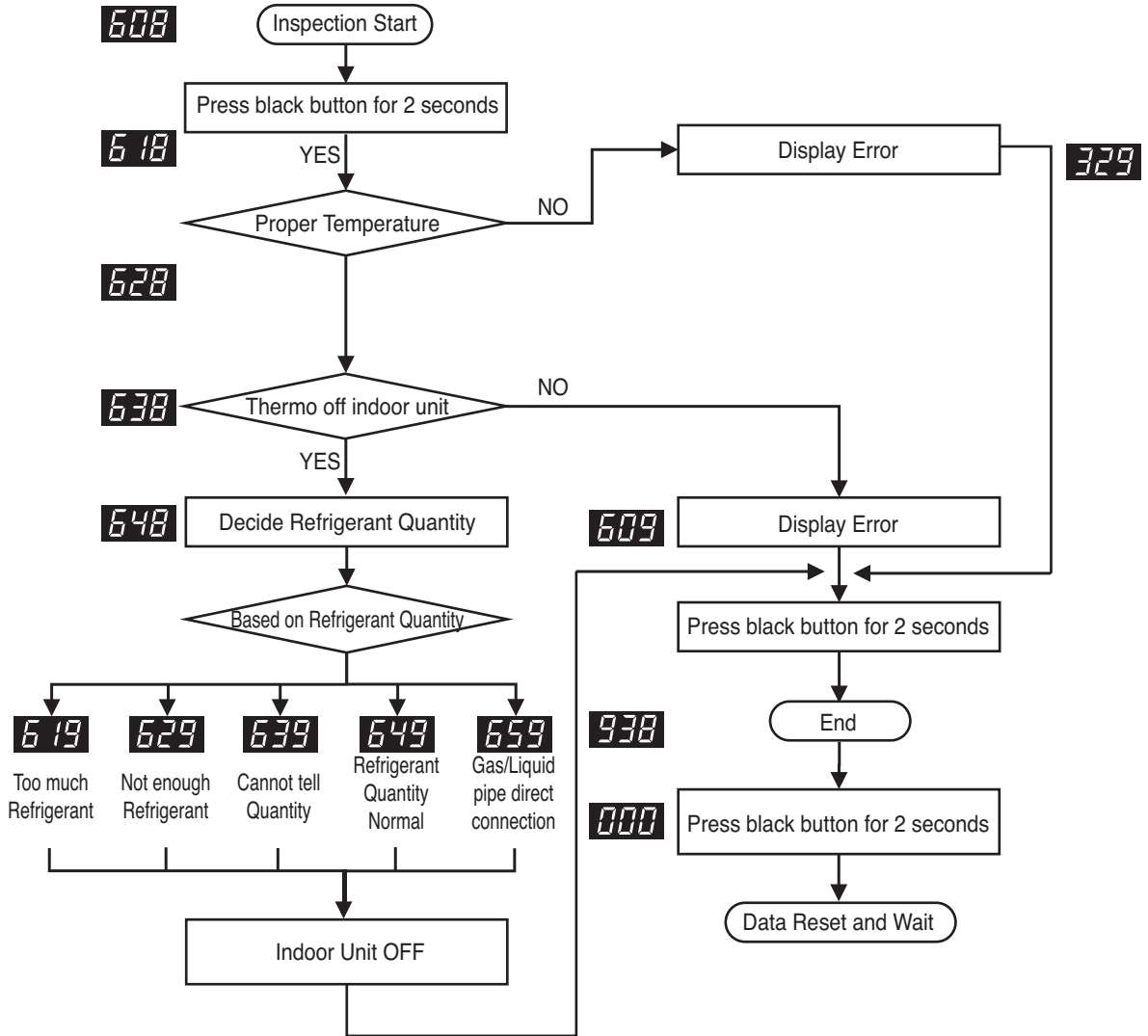

DIP Switch Settings

SVC PCB (Heat pump)

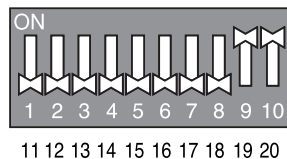
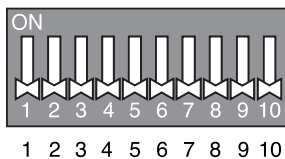

Main PCB (Cooling only)

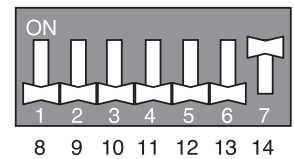
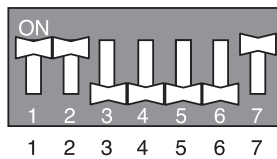

Warning : Please reset SVC/Main PCB before starting this function

Note

1. In case air temperature is out of guaranteed temperature, refrigerant checking function may end without performing refrigerant checking. Use guaranteed temperature range only.
2. During the process of judging refrigerant amount, if the cycle isn't stable, refrigerant checking function may end without performing refrigerant checking.



CAUTION

1. **Guaranteed Temperature range(Error occurs out of guaranteed temperature range)**
 IDU : 20~35°C
 ODU : 0~43°C
2. **Set IDU wired remote controller temperature sensor setting as 'IDU'.**
3. **Make certain that IDU doesn't run with thermo off mode during operation.**

[Error contents about auto refrigerant charging function]

1. **329** : Temperature Range Error (In case that IDU or ODU is out of range)
2. **609** : System Unstable Error (In case, After 45 min operating the system, it does not be stable)

How to Cope with Result of Refrigerant checking

1. If the temperature is not in guaranteed Temperature range, the system will not execute Refrigerant checking and the system will be OFF.
2. **Excess of Refrigerant(619)**
 After remove the 20% of calculated total refrigerant, recharge the refrigerant by using Refrigerant Auto Charging Function.
3. **Scarcity of Refrigerant(629)**
 Charge the refrigerant by using Refrigerant Auto Charging Function.
4. **Impossible to Judge(639)**
 IF the system is not in order, check the other problem except refrigerant.

4.6 IDU EEV Abnormal Checking Function (Set 3,4)

This function judges IDU EEV normal operation. (Judge IDU temperature sensor, IDU to ODU wiring)

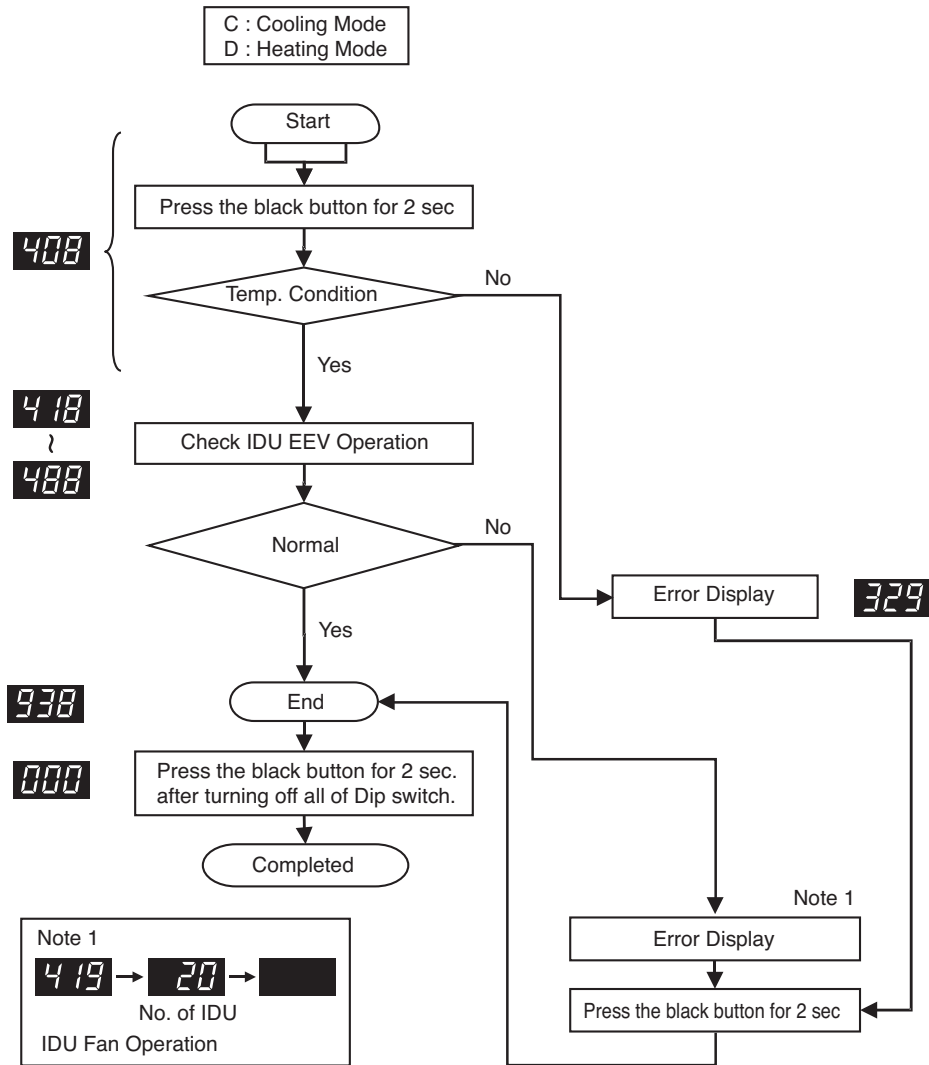

DIP Switch Settings

SVC PCB (Heat pump)

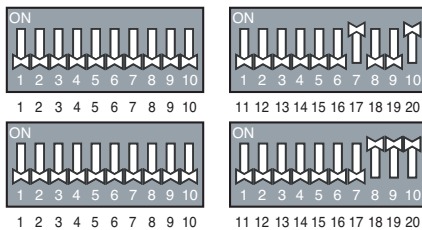

Main PCB (Cooling only)

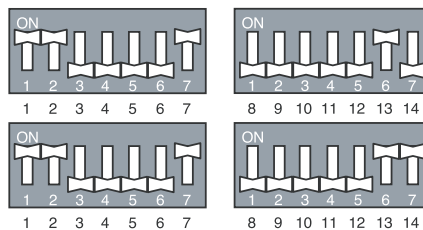

Warning : Please reset SVC/Main PCB before starting this function



CAUTION

1. Guaranteed Temperature range(Error occurs out of guaranteed temperature range)
 - 1) Cooling mode : Indoor 18~32°C, Outdoor : 10~43°C
 - 2) Heating mode : Indoor 18~33°C, Outdoor : -5~24°C

4.7 Integrated Test Runing Function_Cooling Mode (Set 5)

This function is checking process for normal operation of parts and system On operating system.

- All processes carry out included refrigerant amount judge logic and check normal condition of parts on cooling mode.
- This function check only normal condition of parts on heating mode.
- Saved data can check using LGMV.

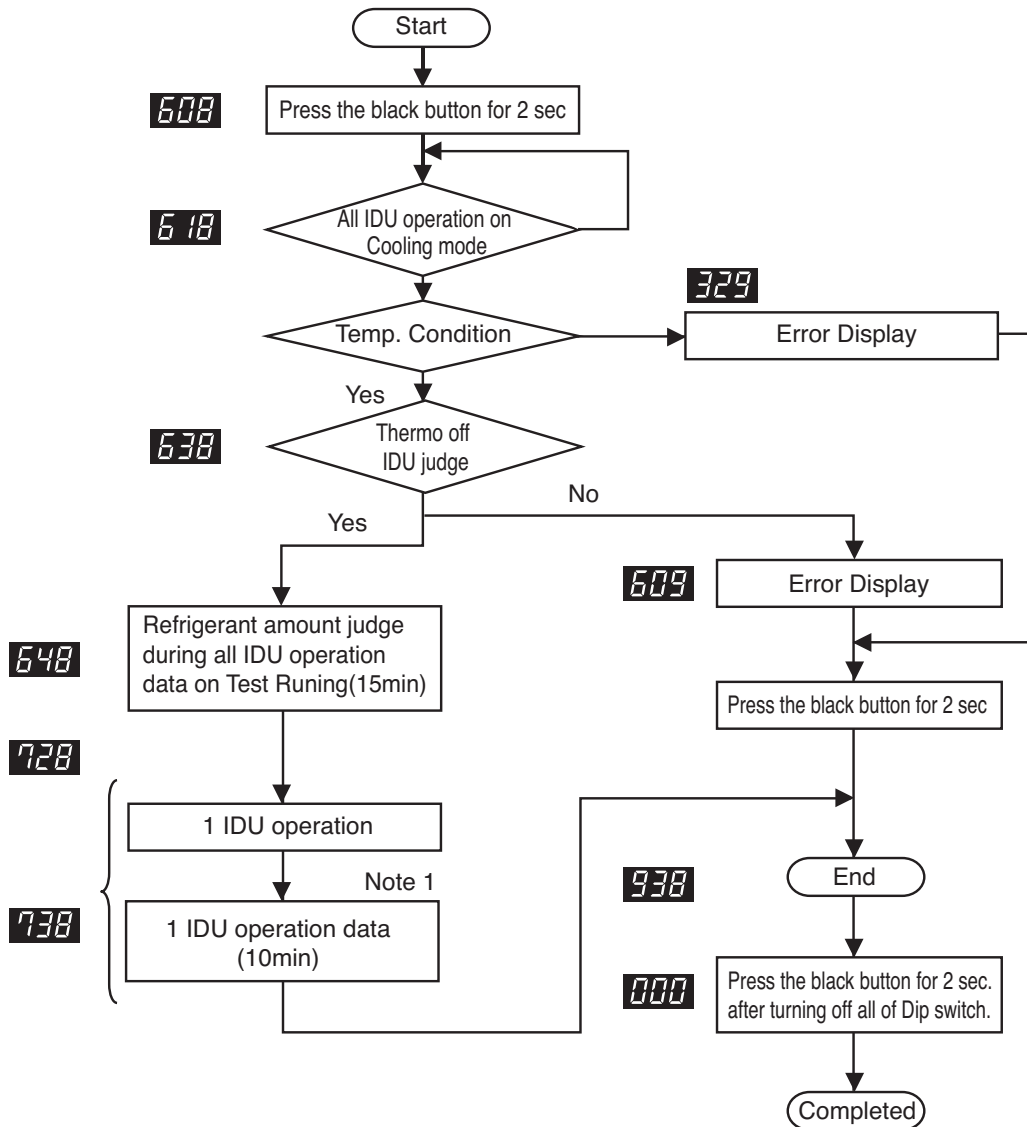

DIP Switch Settings

SVC PCB (Heat pump)

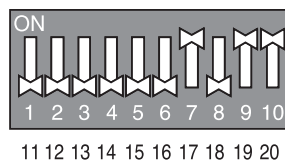
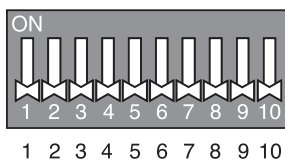

Main PCB (Cooling only)

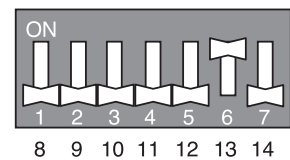
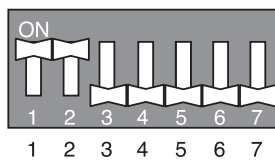

Warning : Please reset SVC/Main PCB before starting this function

Note

1. Judge the normal condition refer to report of Test Running.

4.8 Integrated Test Runing Function_Heating Mode (Set 6)

The function is checking process for normal operation of parts and system On operating system.

- All processes carry out included drefrigerant amount judge logic and check normal condition of parts on heating mode.
- This function check only normal condition of parts on heating mode.
- Saved data can check using LGMV.

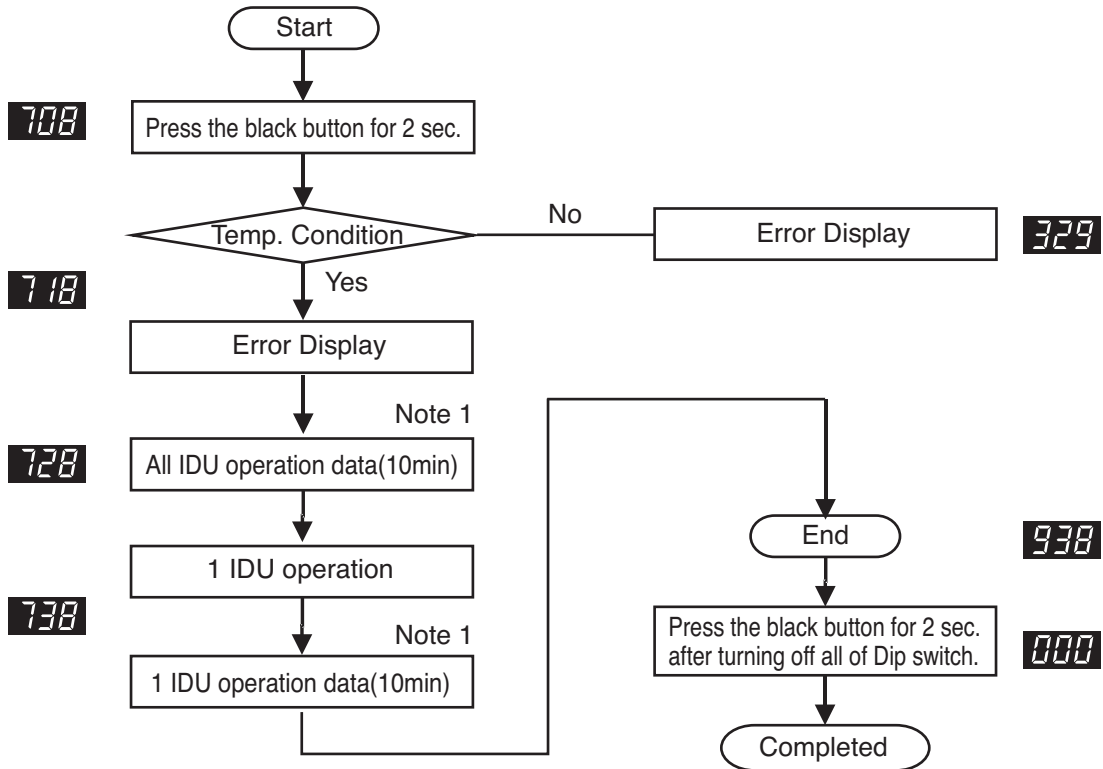

DIP Switch Settings

SVC PCB (Heat pump)

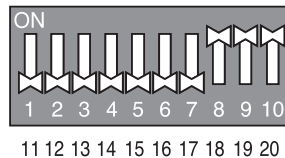
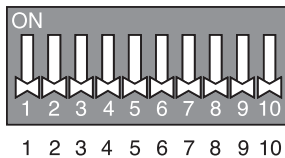

Main PCB (Cooling only)

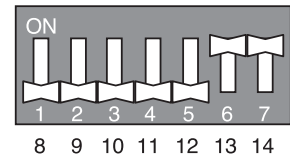
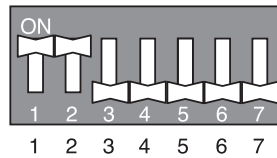

Warning : Please reset SVC/Main PCB before starting this function

Note

1. Judge the normal condition refer to report of Test Running.

**CAUTION****1. Guaranteed Temperature range(Error occurs out of guaranteed temperature range)**

IDU : 20 ~ 35 °C

ODU : 0 ~ 43 °C

2. Set IDU wired remote controller temperature sensor setting as 'IDU'.**3. Make certain that IDU doesn't run with thermo off mode during operation.****[Error contents about auto refrigerant charging function]**

1. **329** : Temperature Range Error (In case that IDU or ODU is out of range)
2. **609** : System Unstable Error (In case, After 45 min operating the system, it does not be stable)

How to Cope with Result of Refrigerant checking

1. If the temperature is not in guaranteed Temperature range, the system will not execute Refrigerant checking and the system will be OFF.
2. **Excess of Refrigerant(619)**
After remove the 20% of calculated total refrigerant, recharge the refrigerant by using Refrigerant Auto Charging Function.
3. **Scarcity of Refrigerant(629)**
Charge the refrigerant by using Refrigerant Auto Charging Function.
4. **Impossible to Judge(639)**
IF the system is not in order, check the other problem except refrigerant.

4.9 Pump Down

This function gathers the refrigerant present in the system to ODU

Use this function to store refrigerant of system in ODU for leakage or IDU replacement.

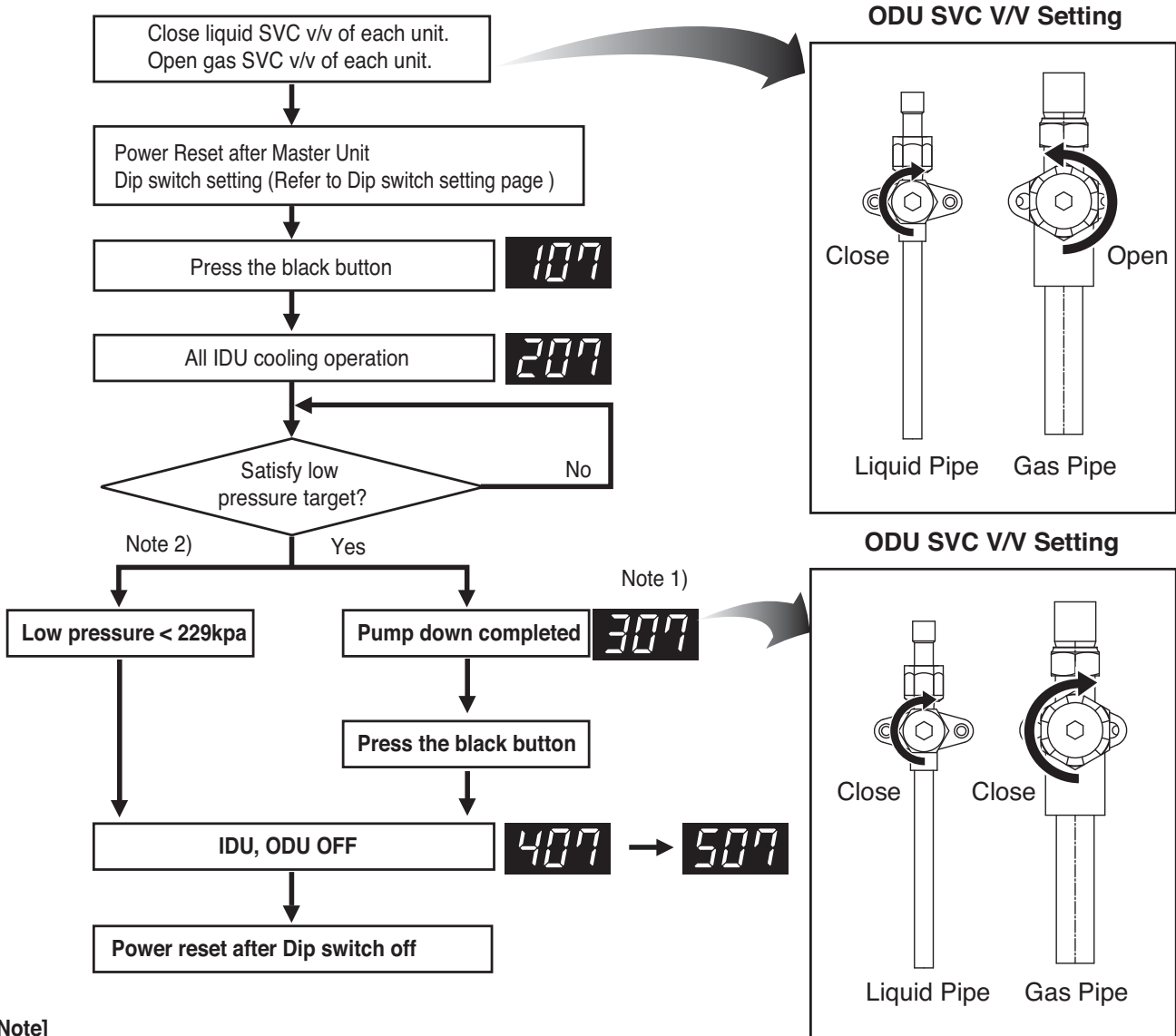

[Note]

If **307** is displayed, close gas SVC V/V of all ODU immediately.

If low pressure descends below 229 kPa, the system turns off automatically. Close the gas SVC V/V immediately.

Caution

1. Use pump down function within guaranteed temperature range
 IDU : 20~32C
 ODU : 5~40C
2. Make certain that IDU doesn't run with thermo off mode during operation
3. Maximum operation time of pump down function is 30 min.
 (in case low pressure doesn't go down)
4. Press black+red button during operation to end pump down.(IDU,ODU off)

407 → **507**

4.10 Pump Out

This function gathers the refrigerant to other ODU and IDU.

Use this function in case of compressor failure, ODU parts defect, leakage.

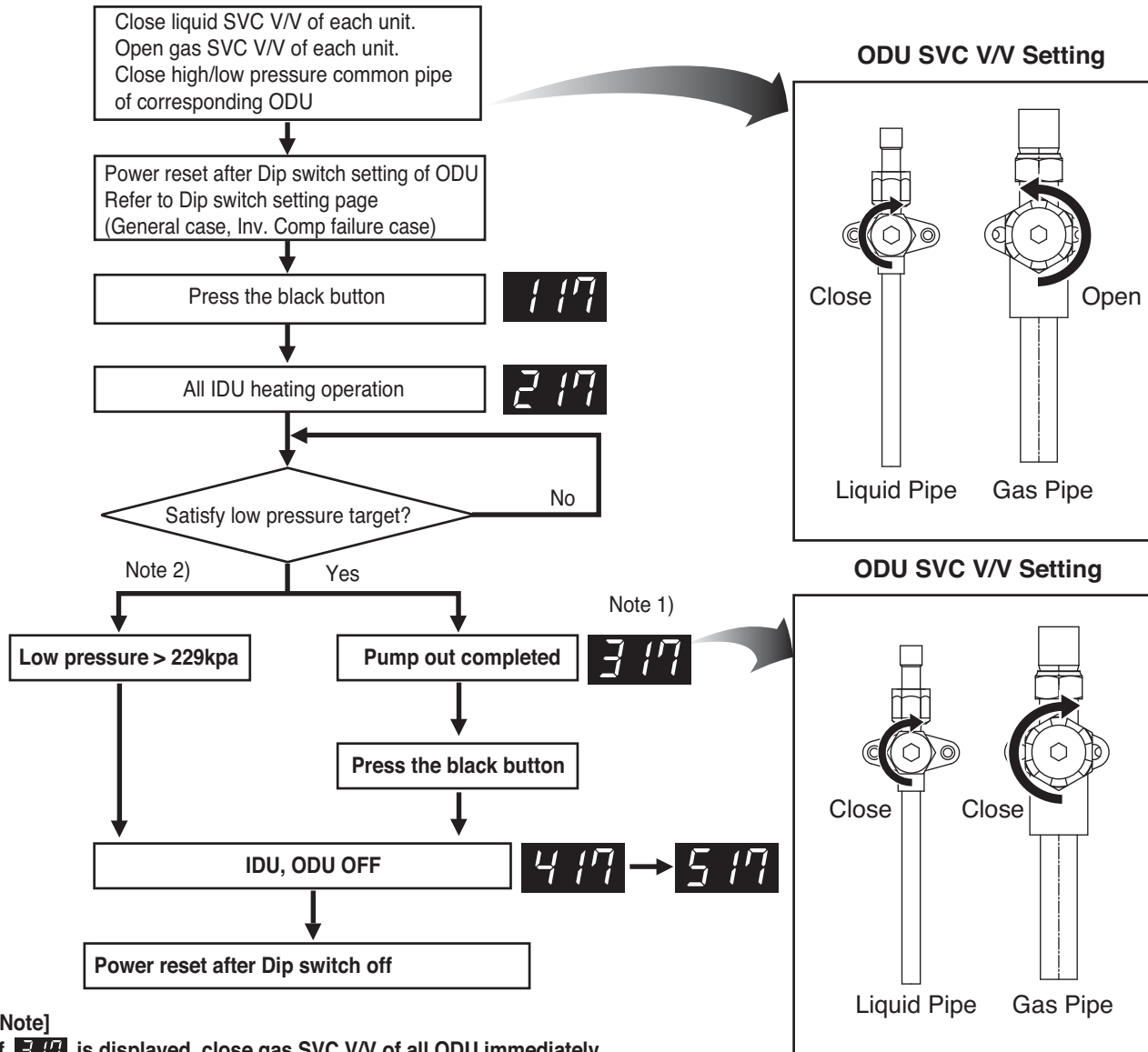

[Note]

If **3 17** is displayed, close gas SVC V/V of all ODU immediately.

If low pressure descends below 229 kPa, the system turns off automatically. Close gas SVC V/V immediately. This function is operating only Heat Pump model.

⚠ Caution

- Use pump out function within guaranteed temperature range
 IDU : 10~30°C
 ODU : 5~40°C
- Make certain that IDU doesn't run with thermo off mode during operation
- Pump out function takes 2~5 min. after compressor start.
 Make certain that IDU doesn't run with thermo off mode during operation (in case low pressure doesn't go down)
- Press black+red button during operation to end pump out. (IDU, ODU off)

4 17 → **5 17**

■ Example. Slave2 ODU Inv Comp failure

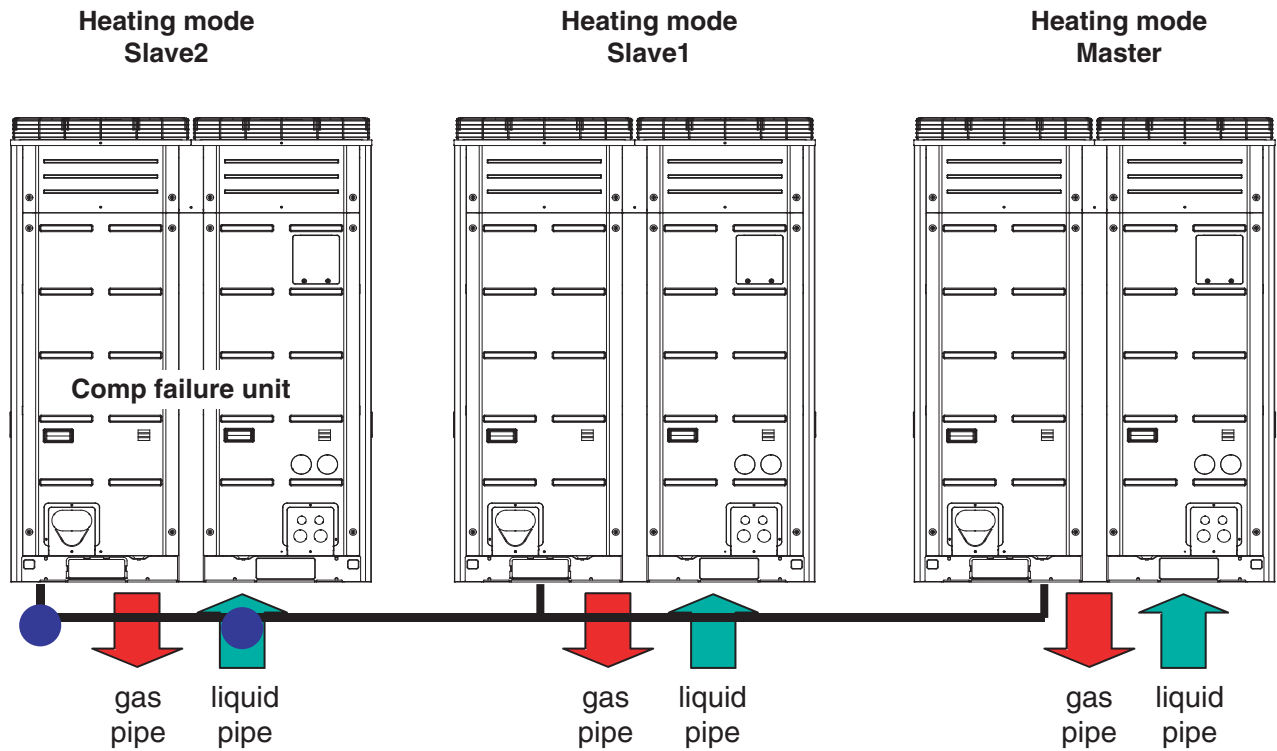

1. Close liquid pipe and common pipe of the unit for pump out operation.
2. Operate pump out
3. Close gas pipe of unit after completion
4. End pump out
5. Close common pipe of no.1,2.
6. Eliminate refrigerant in common pipe after opening the common pipe of corresponding ODU.
Replace compressor and perform vacuum.
7. Add the refrigerant with auto charging function

4.11 Auto Back Up Function_Inverter compressor

This function allows the system to operate in case of inverter compressor failure by backing up compressor automatically.

SVC can be asked by displaying error to the customer every 6 hours.

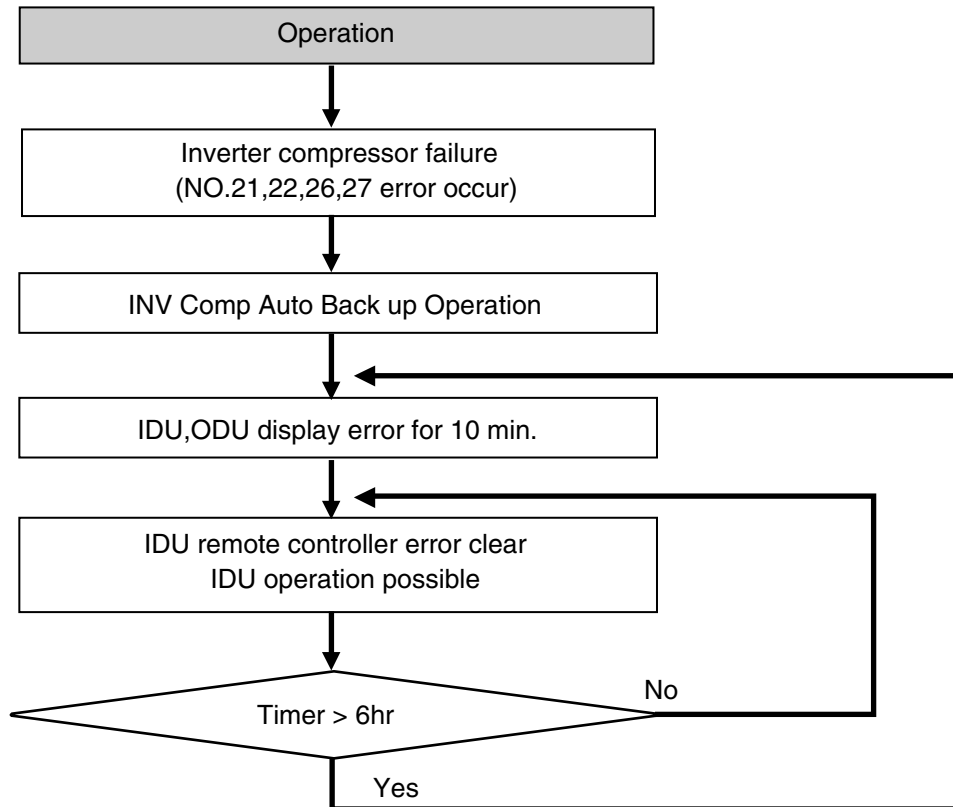

Example) Slave1 Unit INV Comp start failure error occur

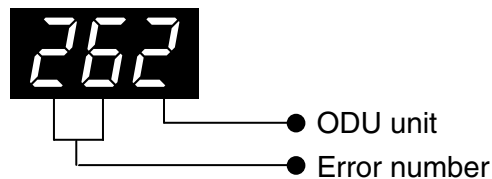

⚠ Caution

1. Request SVC immediately if error occurs.
2. Auto back up is set up to 1 inverter Comp
3. If Inverter Comp Auto Back up starts, error displays for 10 min. every 6 hours.
4. Error displays continuously at the corresponding ODU.

4.12 Auto Back Up Function_constant speed compressor

This function allows the system to operate in case of constant speed compressor failure by backing up compressor automatically.

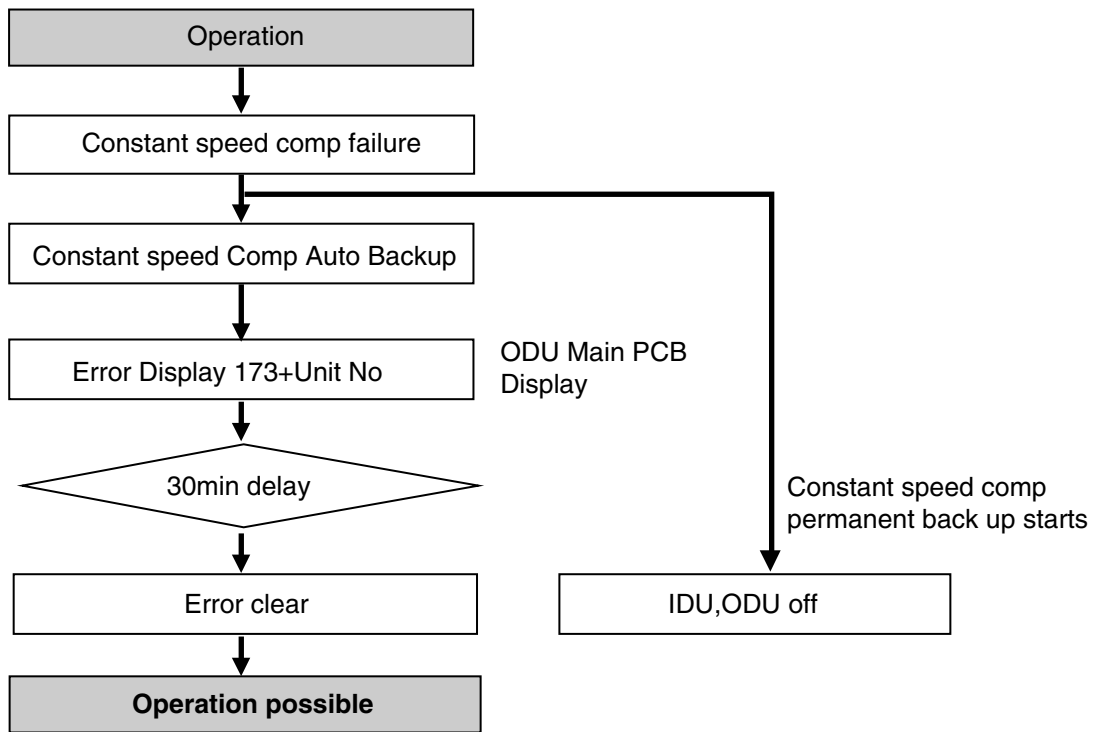

Example) Slave1 Unit constant speed Comp failure(No.173)

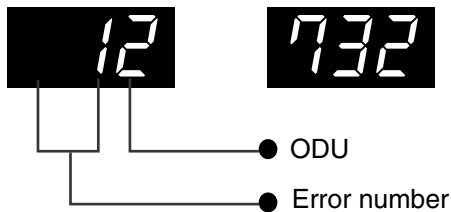

⚠ Caution
 1. Request SVC immediately if error occurs

4.13 Night Low Noise Function

In cooling mode, this function makes the ODU fan operate at low RPM to reduce the fan noise of ODU at night which has low cooling load.

Max. RPM setting method

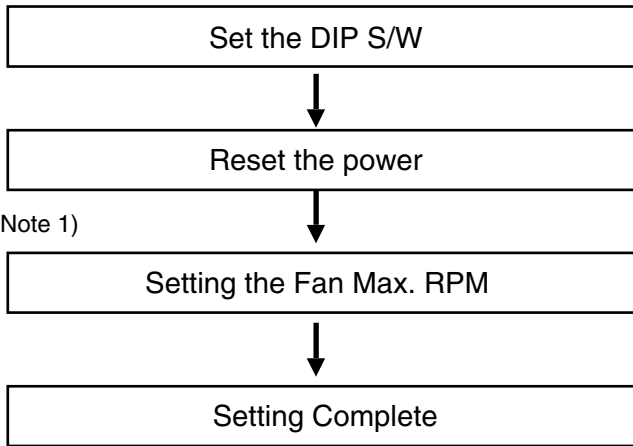

Note 1)

Note 1)
Setting Method for Fan Max. RPM

Step	Black Button	Red Button
1	1 time	1 time
2	2 time	1 time
3	3 time	1 time
4	4 time	1 time
5	5 time	1 time
6	6 time	1 time
7	7 time	1 time
8	8 time	1 time
9	9 time	1 time

RPM / Time Settings

		Capacity			Judgment Time(Hr)	Operation Time(Hr)
Heat Pump		16kW	23~35kW	41~58kW		
Cooling Only		16~23kW	29~41kW	46~58kW		
Step		Fan Maximum RPM				
1					8	9
2	①	730	790	900	6.5	10.5
3					5	12
4					8	9
5	②	620	680	800	6.5	10.5
6					5	12
7					8	9
8	③	510	620	780	6.5	10.5
9					5	12

Noise

		Capacity		
Heat Pump		23~35kW		41~58kW
Cooling Only		16~23kW	29~41kW	46~58kW
Step		Noise(dB)		
Standard		56	58	62
①		53	55	59
②		50	52	56
③		47	49	53

DIP Switch Settings

SVC PCB (Heat pump)

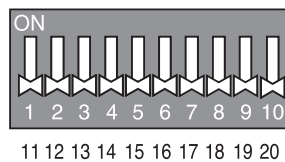
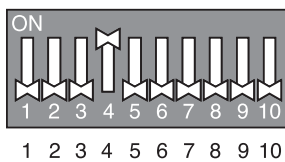

Main PCB (Cooling only)

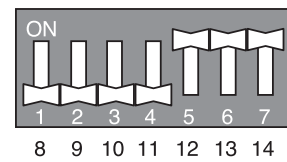
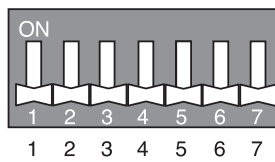

Warning : Please reset SVC/Main PCB before starting this function

CAUTION

1. Request installer to set the function during installation.
2. In case the function is not used, set the dip S/W OFF and reset the power.
3. If ODU RPM changes, cooling capacity may go down.

4.14 Vacuum Mode

This function is used for creating vacuum in the system after compressor replacement, ODU parts replacement or IDU addition/replacement.

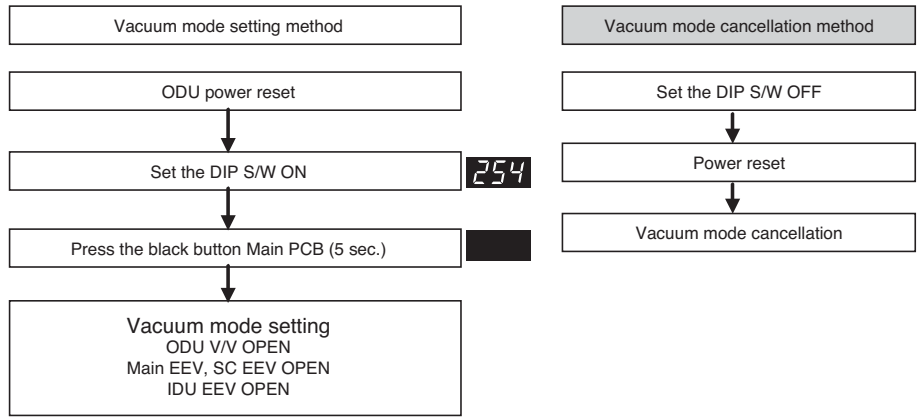

DIP Switch Settings

SVC PCB (Heat pump)

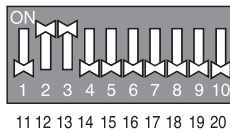
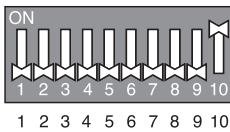

Main PCB (Cooling only)

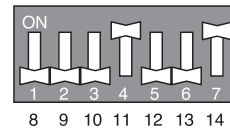
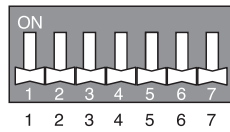

Warning : Please reset SVC/Main PCB before starting this function



CAUTION

ODU operation stops during vacuum mode. Compressor can't operate.

4.15 Static pressure compensation mode

This function is used for creating vacuum in the system after compressor replacement, ODU parts replacement or IDU addition/replacement.

High static pressure mode : Set DIP S/W

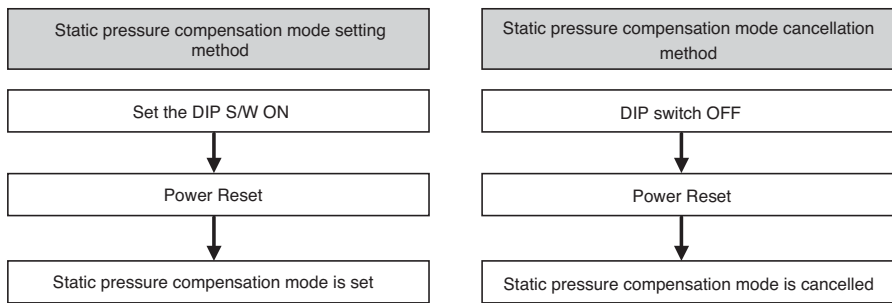

DIP Switch Settings

SVC PCB (Heat pump)

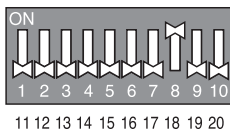
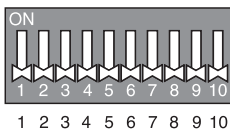

Main PCB (Cooling only)

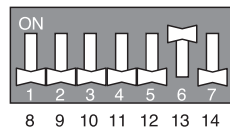
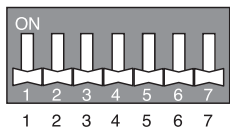

Warning : Please reset SVC/Main PCB before starting this function

4.16 Black Box Function

This function saves data immediately before the error occurs in ODU main PCB, and thus making error analysis cause possible.

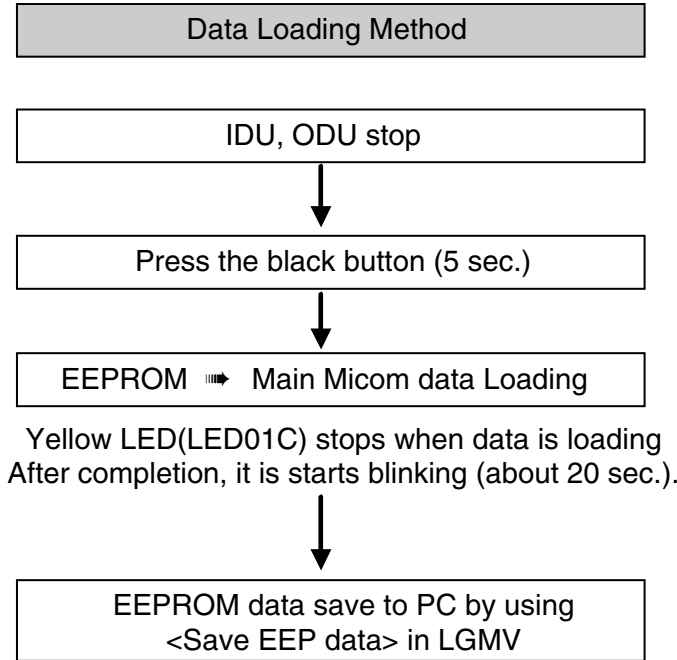

■ Saving process : Making Data → Save EEP data → data saving place select → file save

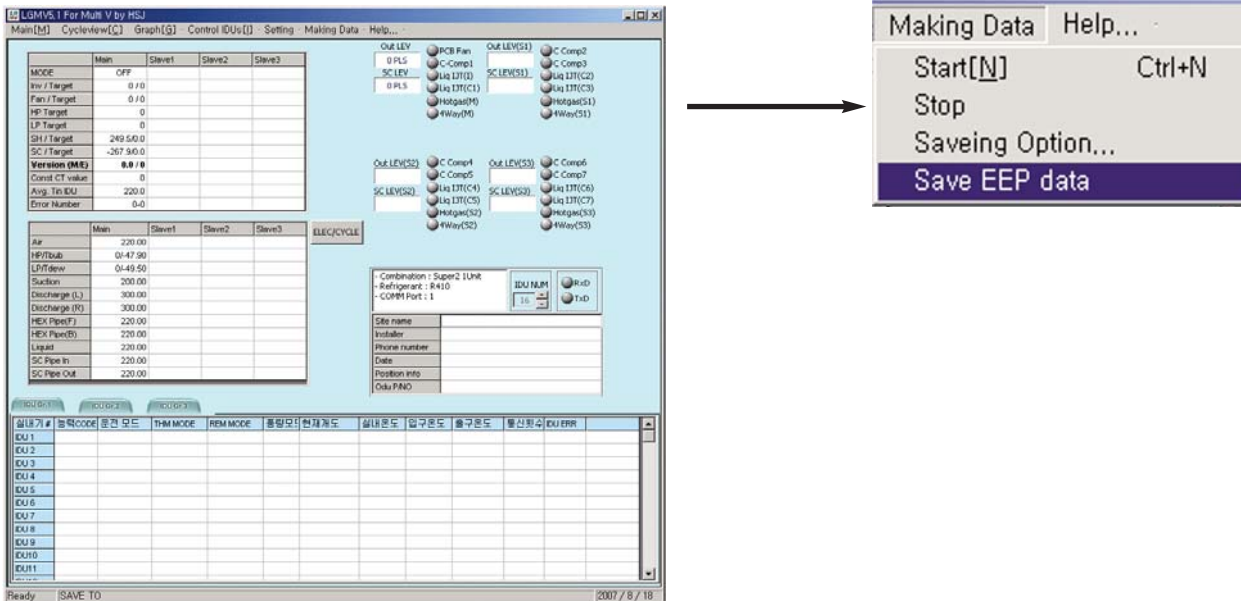

Part 3

PCB Setting and Test Run

Test Run

1. Checks Before Test Run

1	Check to see whether there is any refrigerant leakage, and slack of power or communication cable.
2	<p>Confirm that 500 V megger shows 2.0 MΩ or more between power supply terminal block and ground. Do not operate in the case of 2.0 MΩ or less.</p> <p>NOTE: Never carry out megaohm check over terminal control board. Otherwise the control board would be broken.</p> <p>Immediately after mounting the unit or after leaving it turned off for an extended length of time, the resistance of the insulation between the power supply terminal board and the ground may decrease to approx. 2 MΩ as a result of refrigerant accumulating in the internal compressor. If the insulation resistance is less than 2 MΩ, turning on the main power supply and energizing the crankcase heater for more than 6 hours will cause the refrigerant to evaporate, increasing the insulation resistance.</p>
3	<p>Check if high/low pressure common pipe, liquid pipe and gas pipe valves are fully opened.</p> <p>NOTE: Be sure to tighten caps.</p>
4	<p>Check if there are any problems in automatic addressing or not:</p> <p>Check and confirm that there are no error messages in the display of indoor units or remote controls and LED in outdoor units.</p>



CAUTION

when cutting main power of the Multi V

- Always apply main power of the outdoor unit during use of product (cooling season/heating season).
- Always apply power before 4 hours to heat the crank case heater where performing test run after installation of product. It may result in burning out of the compressor if not preheating the crank case with the electrical heater for more than 4 hours.(In case of the outdoor temperature below 10°C)



CAUTION

Preheat of compressor

- Start preheat operation for 4 hours after supplying main power.
- In case that the outdoor temperature is low, be sure to supply power 4 hours before operation so that the heater is heated(insufficient heating may cause damage of the compressor.)

2. How to cope with Test Run abnormality

The phenomena from main component failure

Component	Phenomenon	Cause	Check method and Trouble shooting
Compressor	Not operating	Motor insulation broken	Check resistance between terminals and chassis
		Strainer clogged	Change strainer
		Oil leakage	Check oil amount after opening oil port
	Stop during running	Motor insulation failure	Check resistance between terminals and chassis
	Abnormal noise during running	R-S-T misconnection	Check compressor R-S-T connection
Outdoor fan	High pressure error at cooling	Motor failure, bad ventilation around outdoor heat exchanger	Check the outdoor fan operation after being turned the outdoor units off for some time. Remove obstacles around the outdoor units
Outdoor EEV	Heating failure, frequent defrosting	Bad connector contact	Check connector
	No operating sound at applying power	Coil failure	Check resistance between terminals
	Heating failure, frozen outdoor heat exchanger part	EEV clogged	Service necessary
	Low pressure error or discharge temperature error	EEV clogged	Service necessary

When system fault occurs, the error code is displayed at indoor unit display or remote control display, the trouble shooting guide is in the service manual

- When CH05/53/11 ERROR occurs, check if auto-addressing has done and communication wiring is ok.

3. DIP Switch Setting

■ Location of setting Switch

Heat Pump (SVC PCB)

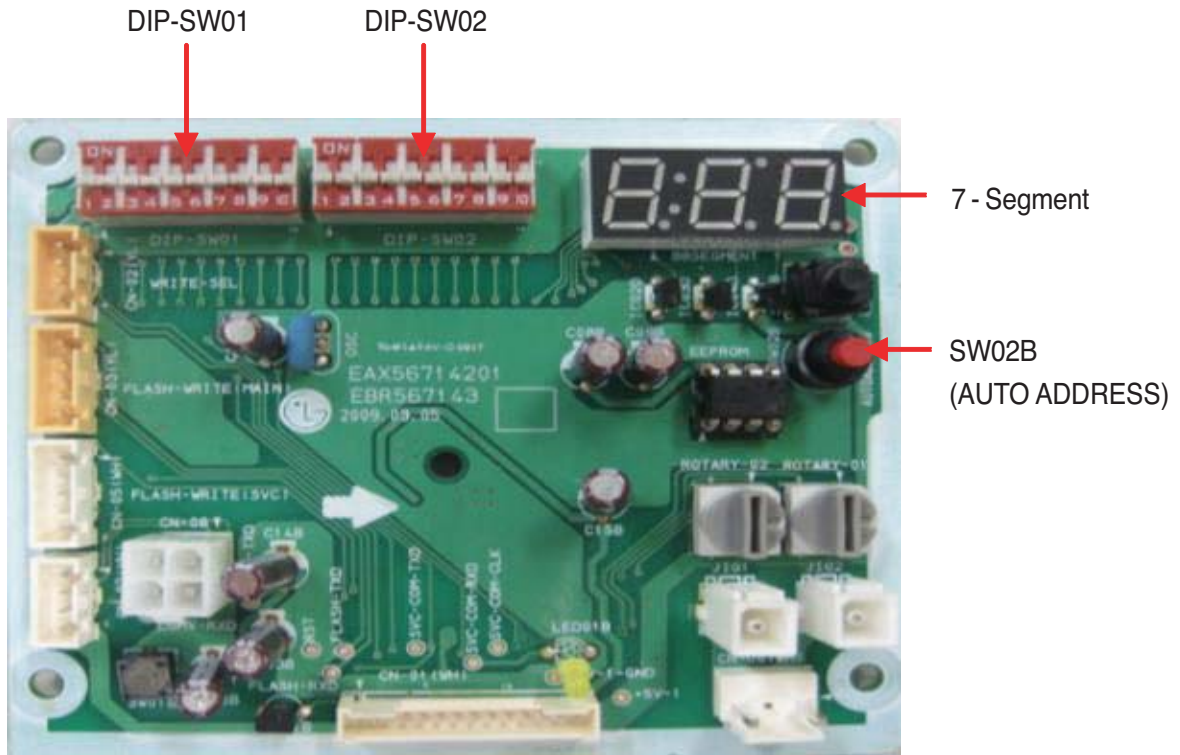

Cooling Only (Main PCB)

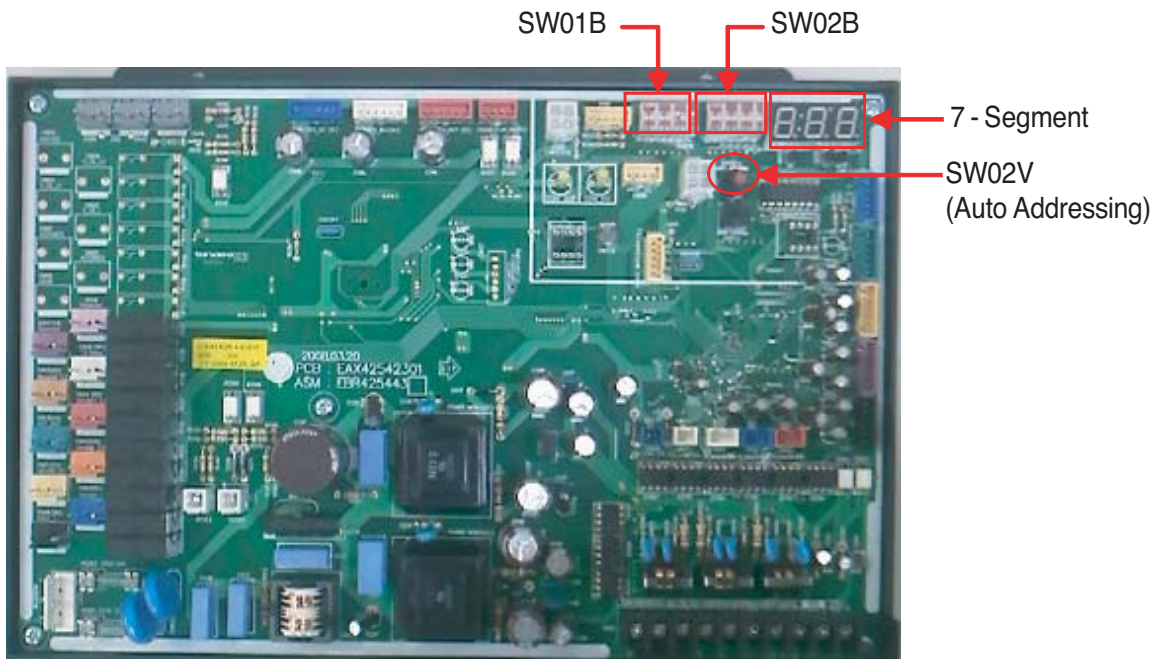

DIP switch setting

■ Checking according to dip switch setting

1. You can check the setting values of the Master outdoor unit from the 7 segment LED.
The dip switch setting should be changed when the power is OFF.
2. It checks whether the input is properly performed without the bad contact of the dip switch or not

■ Checking the setting of the Master unit

The number is sequentially appeared at the 7 segment in 5 seconds after applying the power. This number represents the setting condition. (For example, represents R410A 30HP)

Master model code → Slave1 model code → Slave2 model code → total capacity → 2 → 25 → 150

1 ~ 255 : Master model code
 1 ~ 255 : Slave1 model code
 1 ~ 255 : Slave2 model code
 1 ~ 255 : Slave3 model code

} Refer to table code

6~80HP : HP number(sum of master capacity and slave capacity)

No display : cooling only 2 : heat pump

25 : normal

150 : Model Type(ARUNxxT3)

Example) 30Hp, R410A

16 → 15 → 30 → 2 → 25 → 150

CAUTION

Product may not properly operate if the relevant DIP switch is not properly setup.

Model Code

Model Code	Unit (HP)	Unit	Ref.
11	6	Master & Slave	R410A
12	8		
13	10		
14	12		
15	14		
16	16		
17	18		
18	20		

■ Setting the DIP switch

Heat pump

- If you set the Dip switch when power is on, the changed setting will not be applied immediately. The changed setting will be enabled only when Power is reset or by pressing Reset button.

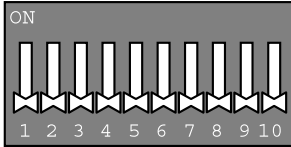

1 2 3 4 5 6 7 8 9 10

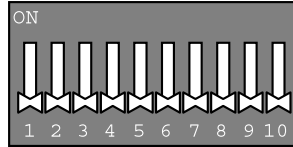

11 12 13 14 15 16 17 18 19 20

		Index	1	2	3	4	5	6	7	8	9	10	11	12	13	14	15	16	17	18	19	20	
Function	Inverter backup		●																				
	Const.1 backup			●																			
	Const.2 backup				●																		
	Unit backup		●	●	●																		
	Night low noise operation (cooling, Heating)					●																	
	Snow removal function							●				x											
	Forced defrost								●			x											
	Snow removal + Forced defrost							●	●			x											
	PLC												●										
	485 communication													x									
	Non-operation indoor unit EEV adjustment														●	x						x	
	Indoor unit target subcooling /overheating adjustment														x	●							x
	Operation indoor unit EEV adjustment														●	●							x
	Cool and heat selector											●					x	●	●				
	Real-time sensor monitoring																	●					x
	Only overall defrost																		●				x
	Static pressure mode																				●	x	x
	PCB test					x	●	x					●										
	Control box test					●	x	x					●										
	COP test mode					●	●	x					●										
	Pump out												●		●	x							
	Pump down												●		x	●							
	Vacuum mode												●		●	●							
	Forced oil return operation												●				x	●	x				
	Sensor test																			●	●	●	●
	Indoor EEV malfunction (heating)																			x	●	x	●
	Indoor EEV malfunction (cooling)																			●	●	x	●
	Auto charging																			●	●	●	●
Refrigerant Checking Function																			x	x	●	●	
Intergrated test operation function (Heating)																			x	●	●	●	
Intergrated test operation function (Cooling)																			●	x	●	●	
ODU Setting	Master unit									x	x												
	Slave1 unit									●	x												
	Slave2 unit									x	●												
	Slave3 unit									●	●												

CAUTION

1. 'X' mark within the table means that the dip switch must be pulled down. If not, the function may not work properly.
2. If the applicable dip switch is not set properly, the product may not work properly.
3. When executing the test operation, check the operating condition of the indoor unit and only execute the operation when all indoor units are stopped.
4. Auto test operation function does not work for the product where only one indoor unit is connected for use.
5. Cooling Only model is not working on functions of Heat Pump model.

Test Run

Cooling only

- If you set the Dip switch when power is on, the changed setting will not be applied immediately. The changed setting will be enabled only when Power is reset or by pressing Reset button.

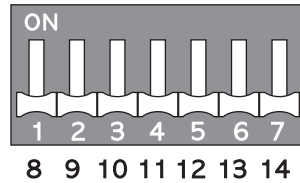
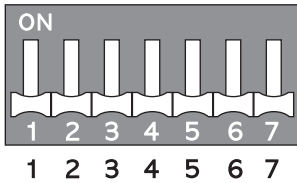

Index		1	2	3	4	5	6	7	8	9	10	11	12	13	14	
Function	Auto charging	●	●					●						x	x	
	Refrigerant Checking Function	●	●					●						x	●	
	Indoor EEV malfunction (Cooling)	●	●					●						●	x	
	Indoor EEV malfunction (Heating)	●	●					●						●	●	
	Integrated test operation function (Cooling)	●	●					x						●	x	
	Integrated test operation function (Heating)	●	●					x						●	●	
	Inverter backup			●												
	Unit backup				●											
	Non-operation indoor unit EEV adjustment	x	x			●	x	x								
	Indoor unit target subcooling/overheating adjustment	x	x			x	●	x								
	Dry contact					●	●	x								
	Snow removal fuction									●	x					
	Forced defrost									x	●					
	Snow removal+Forced defrost									●	●					
	Static pressure mode	x	x											x	●	x
	Nigh low noise operation (Cooling only)													●	x	●
	Night low noise operation (Cooling/Heating)													●	●	●
	Pump down											●				x
	Pump out											●				●
	Forced oil return operation	x	x						●							x
Vacuum mode												●	x	x	●	
Only overall defrost												●				
Master unit						x	x	x								
ODU setting	Slave 1 unit					●	x	●								
	Slave 2 unit					x	●	●								
	Slave 3 unit					●	●	●								

CAUTION

1. 'X' mark within the table means that the dip switch must be pulled down. If not, the function may not work properly.
2. If the applicable dip switch is not set properly, the product may not work properly.
3. When executing the test operation, check the operating condition of the indoor unit and only execute the operation when all indoor units are stopped.
4. Auto test operation function does not work for the product where only one indoor unit is connected for use.
5. Cooling Only model is not working on functions of Heat Pump model.

Part 4

Trouble shooting guide

Trouble shooting guide

1. The phenomena from main component failure	64
2. Checking Method for Key Components	65
2.1 Compressor	65
2.2 Fan Motor	66
2.3 Electronic Expansion Valve.....	67
2.4 Phase Bridge Diode Checking Method	70
2.5 Inverter IPM Checking Method	71
2.6 Fan IPM Checking Method(UX3 chassis)	72
2.7 Fan IPM Checking Method(UX1,2 chassis)	73
2.8 Pressure Sensor(High/Low Pressure Sensor).....	74
2.9 Outdoor Fan	74
2.10 Solenoid Valve	75
2.11 Reverse Valve.....	76
2.12 Temperature Sensor	76
2.13 Others	77
3. Self-diagnosis function.....	78

1. The phenomena from main component failure

The phenomena from main component failure

Component	Phenomenon	Cause	Check method and Trouble shooting
Compressor	Not operating	Motor insulation broken	Check resistance between terminals and chassis
		Strainer clogged	Change strainer
		Oil leakage	Check oil amount after opening oil port
	Stop during running	Motor insulation failure	Check resistance between terminals and chassis
	Abnormal noise during running	R-S-T misconnection	Check compressor R-S-T connection
Outdoor fan	High pressure error in cooling mode operation	Motor failure, bad ventilation around outdoor heat exchanger	Check the fan operation to confirm proper motor functioning. Switch OFF the outdoor unit and remove obstacles, if any, around the HEX. Check connector
Outdoor EEV	Heating failure, frequent defrosting	Bad connector contact	Check resistance between terminals
	No operation sound after switching ON the power supply	Coil failure	Service necessary
	Heating failure, frozen outdoor heat exchanger part	EEV clogged	Service necessary
	Low pressure error or discharge temperature error	EEV clogged	

When system fault occurs, the error code is displayed on the indoor unit display or remote control display. The trouble shooting guide is available in the service manual.

- When CH05/53/11 ERROR occurs, check if auto-addressing has done and communication wiring is ok.

2. Checking Method for Key Components

2.1 Compressor

Check and ensure in following order when error related with the compressor or error related with power occurs during operation:

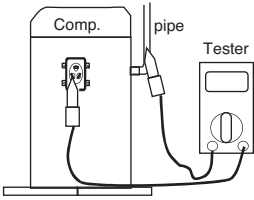
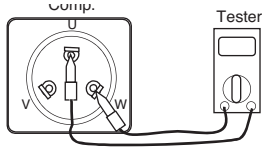
No.	Checking Item	Symptom	Countermeasure												
1	Is how long power on during operation?	1) Power on for 12 hours or more	* Go to No.2.												
		2) Power on for 12 hours or less	* Go to No.2 after applying power for designated time (12 hours).												
2	Does failure appears again when starting operation? Method to measure insulation resistance  Figure 1. Method to measure coil resistance  Figure 2.	1) The compressor stops and same error appears again.	* Check IPM may fail.												
		2) If output voltage of the inverter is stably output. *1	* Check coil resistor and insulation resistor. If normal, restart the unit. If same symptom occurs, replace the compressor. * Insulation resistor: 2MW or more Coil resistor: <table border="1" data-bbox="1084 1112 1461 1251"> <thead> <tr> <th></th> <th>Inverter</th> <th>Constant speed</th> </tr> </thead> <tbody> <tr> <td>U-V</td> <td>0.438Ω ± 7%(25°C)</td> <td>2.19 Ω ± 7%</td> </tr> <tr> <td>U-W</td> <td>0.433Ω ± 7%(25°C)</td> <td>2.13 Ω ± 7%</td> </tr> <tr> <td>W-U</td> <td>0.435Ω ± 7%(25°C)</td> <td>2.26 Ω ± 7%</td> </tr> </tbody> </table>		Inverter	Constant speed	U-V	0.438Ω ± 7%(25°C)	2.19 Ω ± 7%	U-W	0.433Ω ± 7%(25°C)	2.13 Ω ± 7%	W-U	0.435Ω ± 7%(25°C)	2.26 Ω ± 7%
			Inverter	Constant speed											
U-V	0.438Ω ± 7%(25°C)	2.19 Ω ± 7%													
U-W	0.433Ω ± 7%(25°C)	2.13 Ω ± 7%													
W-U	0.435Ω ± 7%(25°C)	2.26 Ω ± 7%													
3) If output voltage of the inverter is unstable or it is 0V. (When incapable of using a digital tester)	* Check the IPM. If the IPM is normal, replace the inverter board. * Check coil resistor and insulation resistor.														

[Cautions when measuring voltage and current of inverter power circuit]

Measuring values may differ depending on measuring tools and measuring circuits since voltage, current in the power supply or output side of the inverter has no sine waveform.

Especially, output voltage changes when output voltage of the inverter has a pattern of pulse wave.

In addition, measuring values appear largely differently depending on measuring tools.

- 1) If using a movable tester when checking that output voltage of the inverter is constant (when comparing relative voltage between lines), always use an analog tester. Especially exercise particular caution if the output frequency of the inverter is low, when using a movable tester, where change of measured voltage values is large between other lines, when virtually same values appear actually or where there is danger to determine that failure of the inverter occurred.
- 2) You can use rectification voltmeter (→+) if using commercial frequency tester when measuring output values of the inverter (when measuring absolute values). Accurate measuring values cannot be obtained with a general movable tester (For analog and digital mode).

2.2 Fan Motor

Checking Item	Symptom	Countermeasure
<p>(1) The fan motor does not operate. Does failure appears again when starting operation?</p> <p>(2) Vibration of the fan motor is large.</p>	1) When power supply is abnormal	<p>* Modify connection status in front of or at the rear of the breaker, or if the power terminal console is at frosting condition.</p> <p>* Modify the power supply voltage is beyond specified scope.</p>
	2) For wrong wiring	<p>* For following wiring.</p> <ol style="list-style-type: none"> 1. Check connection status. 2. Check contact of the connector. 3. Check that parts are firmly secured by tightening screws. 4. Check connection of polarity. 5. Check short circuit and grounding.
	3) For failure of motor	<p>* Measure winding resistance of the motor coils.</p> <ul style="list-style-type: none"> - Panasonic Motor : $9.5 \Omega \pm 5\%$ (@25°C) - LG Motor : $8.6 \Omega \pm 7\%$ (@25°C)
	4) For defective fuse 5) For failure of circuit board	<p>* Replace the fuse if there is defect (Fuse 800V 30A). Replace the circuit board in following procedures if problems occur again when powering on and if there are no matters equivalent to items as specified in above 1) through 4). (Carefully check both connector and grounding wires when replacing the circuit board.)</p> <ol style="list-style-type: none"> 1. Replace only fan control boards. If starting is done, it means that the fan control board has defect. 2. Replace both fan control board and the main board. If starting is done, it means that the main board has defect. 3. If problems continue to occur even after counter-measure of No.1 and No.2, it means that both boards has defect.

2.3 Electronic Expansion Valve

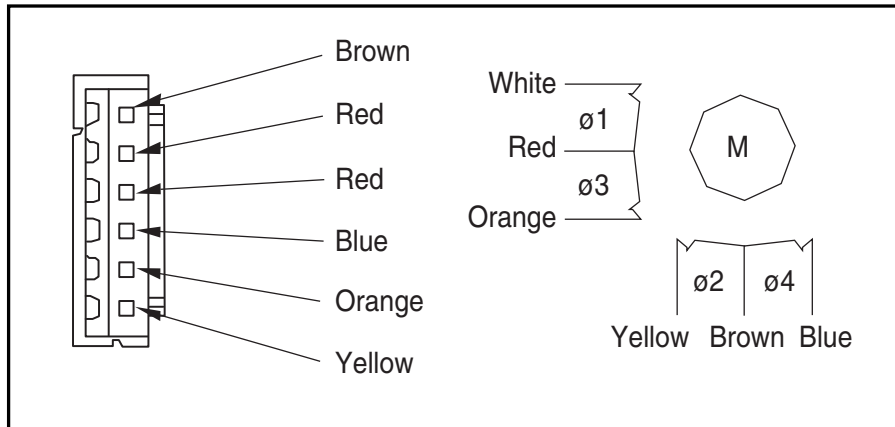

• Pulse signal output value and valve operation

Output(ø) No.	Output state			
	1	2	3	4
ø1	ON	ON	OFF	OFF
ø2	ON	ON	ON	ON
ø3	OFF	OFF	OFF	ON
ø4	OFF	OFF	OFF	OFF

• Output pulse sequence

- In valve close state: 4 → 3 → 2 → 1 → 4
- In valve open state: 1 → 2 → 3 → 4 → 1

- * 1. If EEV open angle does not change, all of output phase will be OFF
- 2. If output phase is different or continuously in the ON state, motor will not operate smoothly and start vibrating.

• EEV valve operation

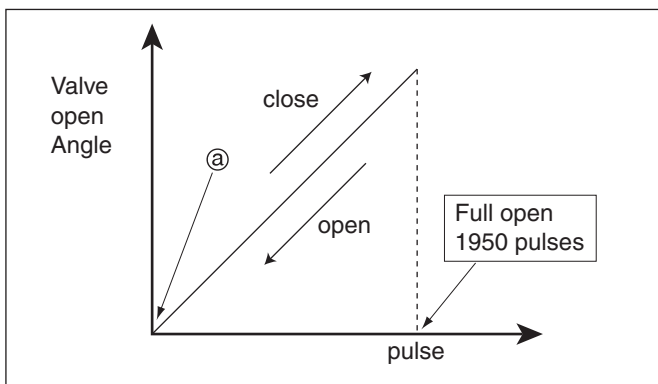

- At power ON, open angle signal of 1400 pulses output and valve position is set to @
If valve operates smoothly, no noise and vibration occurs and if valve is closed. noise occurs.
- Noise from EEV can be confirmed by touching the EEV surface with a screw driver and listening the EEV noise.
- If liquid refrigerant is in EEV, the noise is lower.

• EEV Coil and body(Outdoor unit)

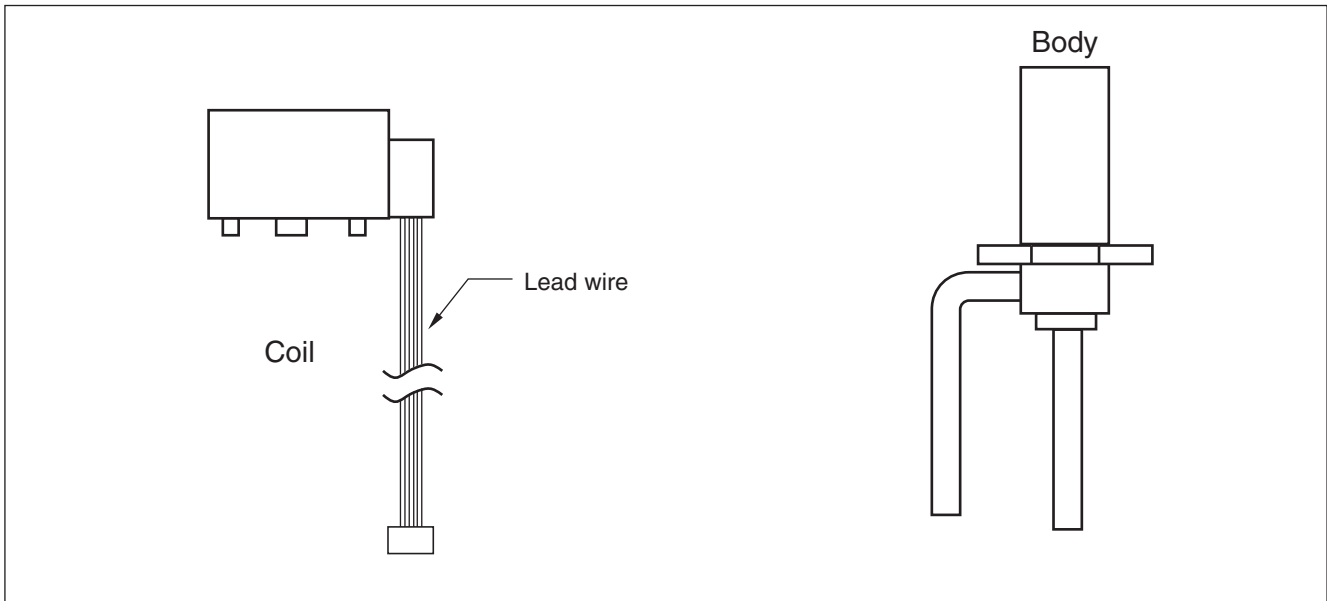

• Remove and assemble the coil

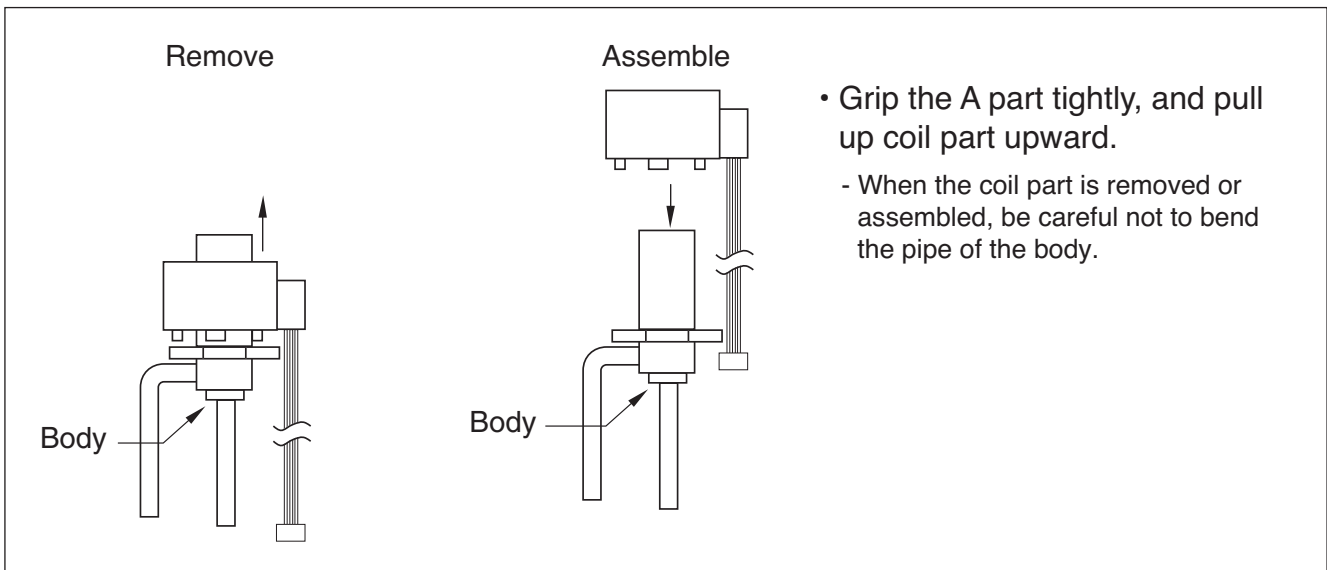

• EEV failure check method

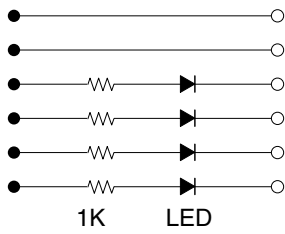
Failure mode	Diagnosis	Repair process	Unit
Microcomputer Driving circuit failure	<p>1. Disconnect the EEV connector form control board and connect testing LED</p>  <p style="text-align: center;">1K LED</p> <p>2. Main power ON, pulse signal is out from EEV for 17 sec. If LEDs do not turn on, or are in on state continuously, then driving circuit is abnormal</p>	Check and replace Indoor unit control board	Indoor unit
EEV locking	1. If EEV is locked, in no load state, the driving motor rotate, and clicking sound always occurs	Replace EEV	Indoor / Outdoor unit
EEV Motor coil short or misconnection	<p>1. Check the resistance between coil terminal (red-white, red-yellow, red-orange, red-blue)</p> <p>2. If the estimated resistance value is in $52 \pm 3\Omega$ then the EEV is normal</p>	Replace EEV	Outdoor unit
	<p>1. Check the resistance between coil terminal (brown-white, brown-yellow, brown-orange, brown-blue)</p> <p>2. If the estimated resistance value is in $150 \pm 10\Omega$ then the EEV is normal</p>	Replace EEV	Indoor unit
Full closing (valve leakage)	<p>1. Operate indoor unit with FAN mode and operate another indoor unit with COOLING mode</p> <p>2. Check indoor unit(FAN mode) liquid pipe temperature (from operation monitor of outdoor unit control board)</p> <p>3. When fan rotate and EEV is fully closed, if there is any leakage, then the temperature is down</p> <p>If estimated temperature is very low in comparison with suction temperature which is displayed at remote controller then the valve is not fully closed</p>	If the amount of leakage is much, Replace EEV	Indoor unit

2.4 Phase Bridge Diode Checking Method

Internal circuit diagram

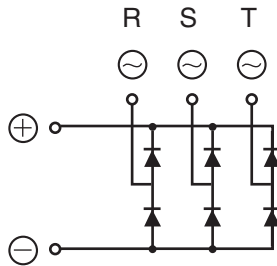

Appearance

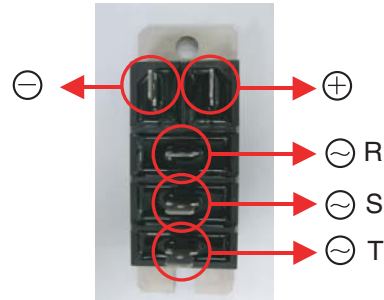

1. Wait until inverter PCB DC voltage gets discharged, after the main power switch off.
2. Pull out all the connectors connected with 3 phase bridge diode.
3. Set multi tester in diode mode.
4. Measured value should be 0.4~0.7V measuring as below table.
5. In case the measured value is different from the table, set multi tester to resistance mode and measure. If the value is small (0 Ω) or high (hundreds M Ω), PCB needs to be replaced.
6. In case that bridge diode is damaged, check if inverter PCB assembly(IPM) is needed to be replaced.

Diode terminal Tester terminal	+ terminal: black(-)	- terminal: red(+)
	R(~) : red(+)	0.4 V ~ 0.7 V
S(~) : red(+)	0.4 V ~ 0.7 V	-
T(~) : red(+)	0.4 V ~ 0.7 V	-
R(~) : black(-)	-	0.4 V ~ 0.7 V
S(~) : black(-)	-	0.4 V ~ 0.7 V
T(~) : black(-)	-	0.4 V ~ 0.7 V

* Red(+) and black(-) are the measuring terminals of multi tester.

CAUTION

- Check the electric parts of c/box, 10 minutes after switching off the main supply and checking DC voltage is discharged. Otherwise, there is chance of getting electric shock.
- There is chance of electric shock by charged voltage.

2.5 Inverter IPM Checking Method

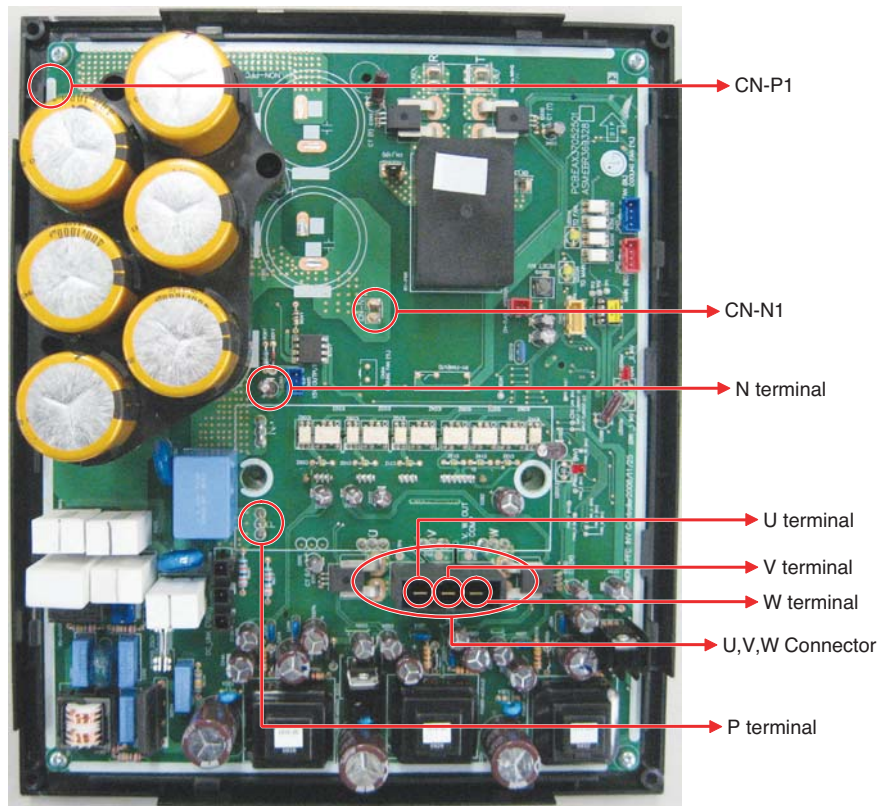

1. Wait until inverter PCB DC voltage is discharged after main power off.
2. Pull out CN-P1, CN-N1 connectors and U,V,W COMP connector connected with the inverter PCB.
3. Set multi tester to resistance mode.
4. If the value between P and N terminal of IPM is short(0Ω) or open(hundreds $M\Omega$), PCB needs to be replaced.(IPM damaged)
5. In the measured value with resistance mode should be within $28K\ \Omega \pm 10\%$.
6. In case measured value is different from the table, PCB needs to be replaced.(PCB damaged).

	P terminal : black (-)	N terminal : red (-)
U terminal : red(+)	$28K\ \Omega \pm 10\%$	Open
V terminal : red(+)	$28K\ \Omega \pm 10\%$	Open
W terminal : red(+)	$28K\ \Omega \pm 10\%$	Open
	P terminal : red(+)	N terminal : red (+)
U terminal : black(-)	Open	$28K\ \Omega \pm 10\%$
V terminal : black(-)	Open	$28K\ \Omega \pm 10\%$
W terminal : black(-)	Open	$28K\ \Omega \pm 10\%$

* Red(+) and black(-) are the measuring terminals of multi tester.

2.6 Fan IPM Checking Method

1. Wait until inverter PCB DC voltage gets discharged after the main power switch off.
2. Pull out DC connector and U,V,W fan motor connector connected with fan PCB
3. Set multi tester in resistance mode .
4. If the value between P and N terminal of IPM is small (0Ω) or tens $K\Omega$, PCB needs to be replaced (IPM damaged).
5. In case the measured value is open(hundreds $K\Omega$), measure resistance mode, and the value should be within $35 K\Omega \pm 10\%$ as shown below table.
6. If the measured value is different from the value given in the table, PCB is needs to be replaced.

	P terminal : black (-)	N terminal : red (-)
U terminal : red(+)	$35K \Omega \pm 10\%$	Open
V terminal : red(+)	$35K \Omega \pm 10\%$	Open
W terminal : red(+)	$35K \Omega \pm 10\%$	Open
	P terminal : red(+)	N terminal : red (+)
U terminal : black(-)	Open	$35K \Omega \pm 10\%$
V terminal : black(-)	Open	$35K \Omega \pm 10\%$
W terminal : black(-)	Open	$35K \Omega \pm 10\%$

* Red(+) and black(-) are the measuring terminals of multi tester.

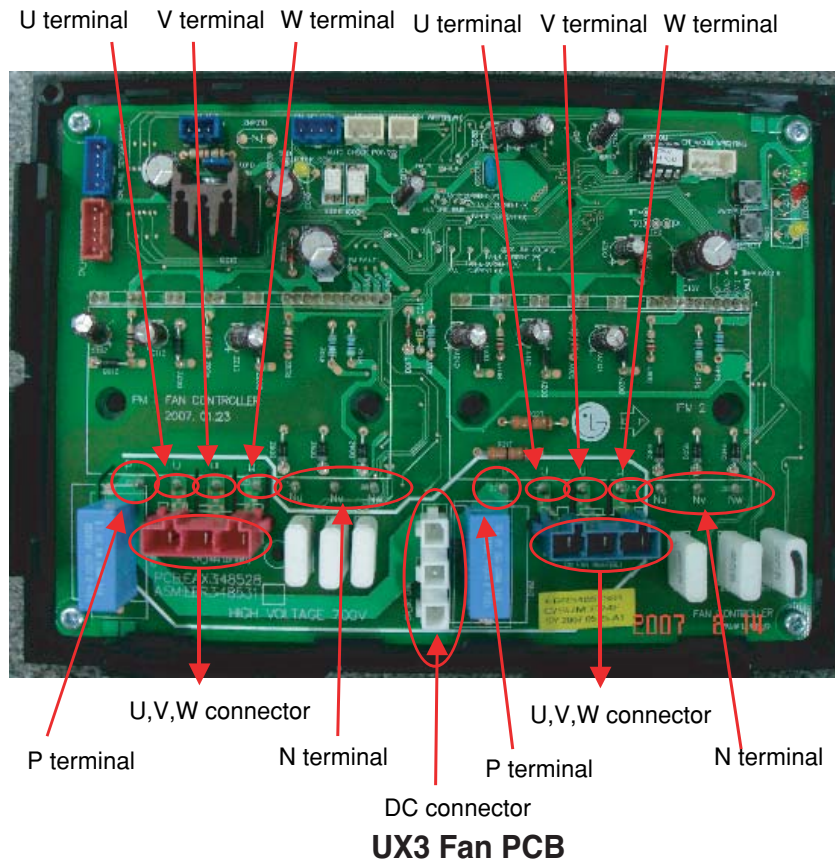

2.7 Fan IPM Checking Method

1. Wait until inverter PCB DC voltage gets discharged after the main power switch off.
2. Pull out DC connector and U,V,W fan motor connector connected with fan PCB
3. Set multi tester in resistance mode .
4. If the value between P and N terminal of IPM is small (0Ω) or tens $K\Omega$, PCB needs to be replaced (IPM damaged).
5. In case the measured value is open(hundreds $K\Omega$), measure resistance mode, and the value should be within $35 K\Omega \pm 10\%$ as shown below table.
6. If the measured value is different from the value given in the table, PCB is needs to be replaced.

	P terminal : black (-)	N terminal : red (-)
U terminal : red(+)	$35K \Omega \pm 10\%$	Open
V terminal : red(+)	$35K \Omega \pm 10\%$	Open
W terminal : red(+)	$35K \Omega \pm 10\%$	Open
	P terminal : red(+)	N terminal : red (+)
U terminal : black(-)	Open	$35K \Omega \pm 10\%$
V terminal : black(-)	Open	$35K \Omega \pm 10\%$
W terminal : black(-)	Open	$35K \Omega \pm 10\%$

* Red(+) and black(-) are the measuring terminals of multi tester.

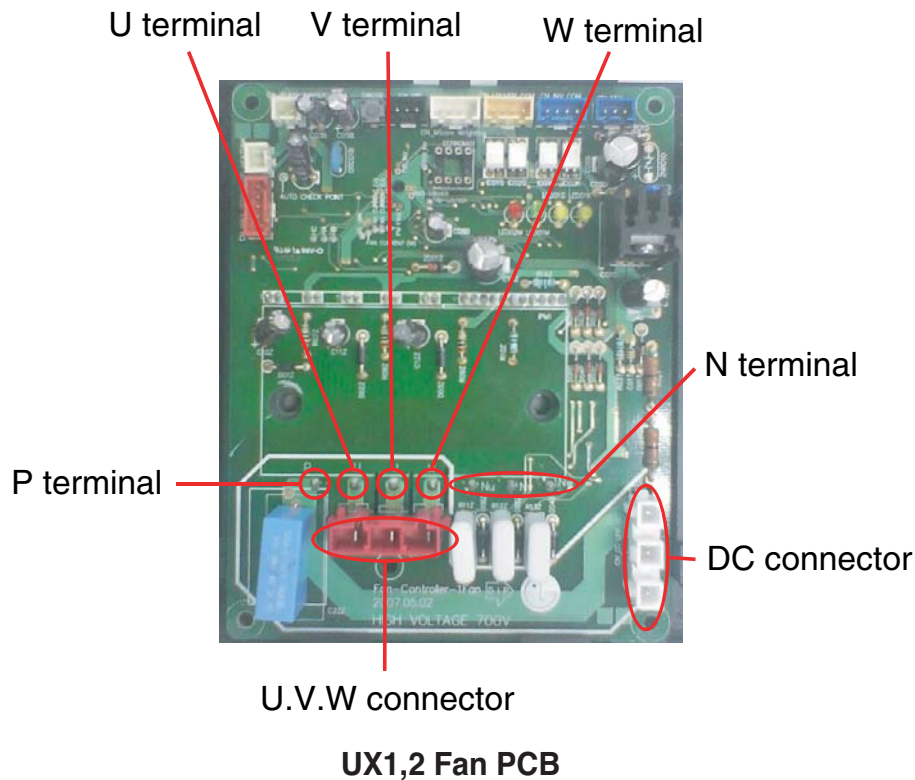

2.8 Pressure Sensor(High/Low Pressure Sensor)

Connect manifold gauge to the service valve of outdoor unit, and compare the output of high pressure sensor to the output of low pressure sensor to detect the defect.

below) Compare the output of pressure sensor to the output of manifold gauge pressure using the table below. Read the pressure clearly between black and white as the composition of pressure sensor.

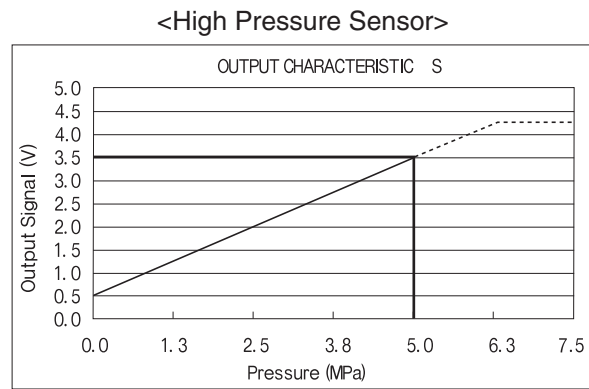
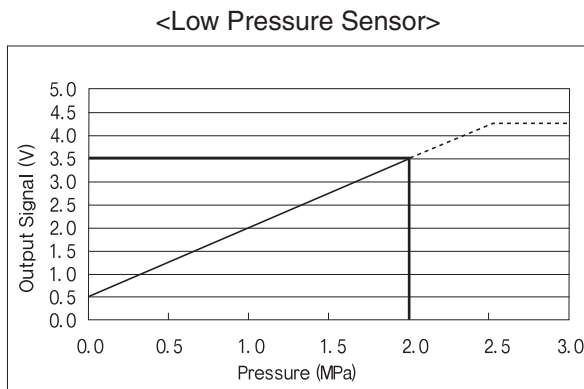

- 1) If the pressure of manifold gauge is 0~1kg/cm², it indicates the pressure got lower due to the leakage of refrigerant. Find the place of leakage and fix it.
- 2) If the difference of the outputs of high and low pressure is in the range of 1kg/cm², the pressure sensor is normal.
- 3) If the difference of the outputs of high and low pressure is over 1kg/cm², the pressure sensor is out of order, it need to be replaced.
- 4) The composition of pressure sensor

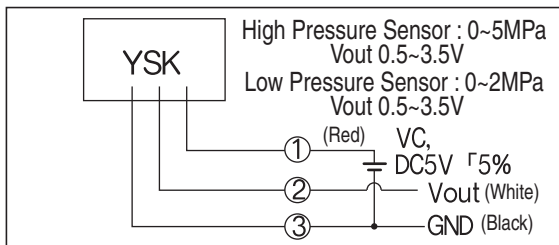

The pressure sensor is composed like the circuit picture shown above. If DC 5V voltage flows on red and black wire, voltage would be made between the white and black wire. The pressure which is equivalent to the pressure output is shown in the table above.

2.9 Outdoor Fan

- 1) The outdoor fan is controlled by the inverter motor which can control the number of rotations.
- 2) The outdoor fan is controlled by the high/low pressure of the outdoor unit after the operation of compressor.
- 3) There is possibility that the outdoor fan does not operate due to low capacity operation or low outdoor temperature even if the compressor is operating. This does not mean breakdown of the unit, the fan will start operating if it reaches the set point.

2.10 Solenoid Valve

Check the conformity of the operation of solenoid valve to the output signal of control board.

1) Hot gas bypass valve

1. When the compressor starts operating, hot gas valve will be on for 1 minute. Check if there is operation noise or piping vibration on the solenoid valve.
2. To get rid of the difference of high and low pressure of system after stop operating the compressor, turn the valve on after 5 seconds.
3. Turn the hot gas valve on if the temperature of compressor suction pipe is lower than ranged temperature.
4. Hot gas valve can be kept on by the condition of cycle operation, this does not indicate the breakdown of the unit.
5. The change of the operation condition by the operation of solenoid valve can be checked by the before and behind temperature of bypass piping and the sound of refrigerant.
6. Insulation resistance in the state of connecting the valve to coil should be over 100mΩ when measure it with DC mega tester(DC 500V).

2) Oil solenoid valve

1. It is located in the bottom of accumulator, and it starts operating after some period of time of the compressor operation to provide oil stored in the bottom of the accumulator to the compressor.
2. When the compressor starts operating, oil solenoid valve will be on for 2 minutes. Check if there is operation noise or piping vibration on the solenoid valve.
3. It turns on right after the compressor stop operating.
4. Solenoid valve can turn on and off repeatedly by the condition of cycle operation; this does not indicate the breakdown of the unit.
5. Insulation resistance in the state of connecting the valve to coil should be over 100mΩ when measure it with DC mega tester(DC 500V).

3) Partial defrosting solenoid valve

1. Defrost operation eliminates ice attached on heat exchanger, recovering performance of heat exchanger.
2. Two solenoid valves will be on by turns in the extent of 6 minutes when separated defrosting is on.
3. It will be turned off right after the end of separated defrosting.
4. The change of the operation condition by the operation of solenoid valve can be checked by the before and behind temperature of bypass piping and the sound of refrigerant.
5. Insulation resistance in the state of connecting the valve to coil should be over 100mΩ when measure it with DC mega tester(DC 500V).

2.11 Reverse Valve

1. Keep it off before the outdoor unit is powered on and the indoor unit is turned on.
2. Cooling, defrosting, oil recovery : OFF, heating : ON
3. When alternating cooling to heating, transform 4 way valve during re-starting for 3 minutes.
4. To check the mode of cooling/heating operation of 4 way valve, touch the piping surface of low pressure service valve.
5. Refrigerant flowchart of 4 way valve

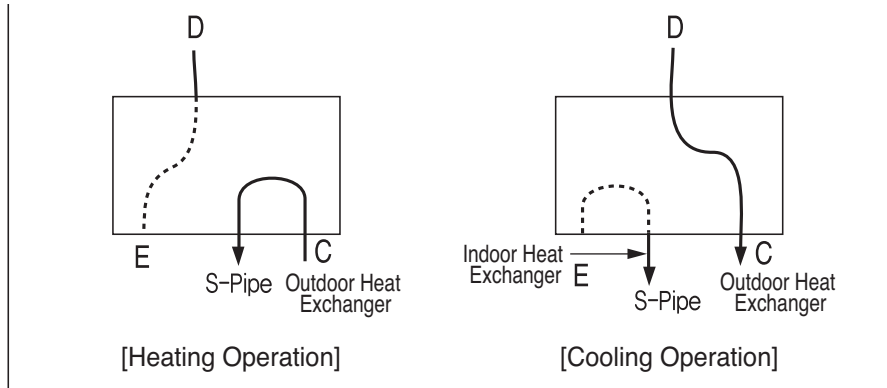

6. Insulation resistance in the state of connecting the valve to coil should be over 100mΩ when measure it with DC mega tester(DC 500V).

2.12 Temperature Sensor

- 1) outdoor temperature sensor : TH1
- 2) Suction pipe(S-pipe) temperature sensor : TH2
- 3) Discharge pipe(D-pipe) temperature sensor : TH3
- 4) Outdoor heat exchanger (center of condenser) temperature sensor :TH2
 1. Check the condition of installation and the contact of temperature sensor.
 2. Check whether the connector contact of temperature sensor is normal.
 3. Measure the resistance of temperature sensor.

	TH1	TH2	TH3
Resistance	10KΩ±1%(@25°C)	5KΩ±1%(@25°C)	200KΩ±1%(@25°C)
	1.07KΩ±3.3%(@85°C)	535KΩ±3.3%(@85°C)	28KΩ±7.7%(@85°C)

2.15 Others

Electrolytic capacitor and resistor for voltage distribution

- 1) Disconnect an terminal of voltage distribution resistor from each DC link electrolytic capacitor
- 2) Set the multi meter to resistance mode, connect the probe to +,- terminal of the capacitor. If the estimated resistance value is increase continuously without short(value is 0), then the resistor is normal
- 3) Set the multi meter to resistance mode, confirm that the resistance value of the resistor is around 270 kOhm



Check and replace inferior components

3. Self-diagnosis function

Self-Diagnosis Function

Error Indicator

- This function indicates types of failure in self-diagnosis and occurrence of failure for air condition.
- Error mark is displayed on display window of indoor units and wired remote controller, and 7-segment LED of outdoor unit control board as shown in the table.
- If more than two troubles occur simultaneously, lower number of error code is first displayed.
- After error occurrence, if error is released, error LED is also released simultaneously.

Error Display

1st,2nd LED of 7-segment indicates error number, 3rd LED indicates unit number.

Ex) 211 : No.21 error of master unit 213 : No.21 error of slave2 011 → 051 : No.105 error of master unit

* Refer to the DX-Ventilation manual for DX-Ventilation error code

Display			Title	Cause of Error	
Indoor unit related error	0	1	-	Air temperature sensor of indoor unit	Air temperature sensor of indoor unit is open or short
	0	2	-	Inlet pipe temperature sensor of indoor unit	Inlet pipe temperature sensor of indoor unit is open or short
	0	3	-	Communication error : wired remote controller ↔ indoor unit	Failing to receive wired remote controller signal in indoor unit PCB
	0	4	-	Drain pump	Malfunction of drain pump
	0	5	-	Communication error : outdoor unit ↔ indoor unit	Failing to receive outdoor unit signal in indoor unit PCB
	0	6	-	Outlet pipe temperature sensor of indoor unit	Outlet pipe temperature sensor of indoor unit is open or short
	0	7	-	Different operation mode	Operation mode between indoor unit and outdoor unit is different
	0	9	-	Indoor EEPROM Error	In case when the serial number marked on EEPROM of Indoor unit is 0 or FFFFFFFF
	1	0	-	Poor fan motor operation	Disconnecting the fan motor connector/Failure of indoor fan motor lock
	1	7	-	Inlet Air temperature sensor of FAU	Air temperature sensor of indoor unit is open or short
Outdoor unit related error	2	1	1	Master Outdoor Unit Inverter Compressor IPM Fault	Master Outdoor Unit Inverter Compressor Drive IPM Fault
			2	Slave1 Outdoor Unit Inverter Compressor IPM Fault	Slave1 Outdoor Unit Inverter Compressor Drive IPM Fault
			3	Slave2 Outdoor Unit Inverter Compressor IPM Fault	Slave2 Outdoor Unit Inverter Compressor Drive IPM Fault
			4	Slave3 Outdoor Unit Inverter Compressor IPM Fault	Slave3 Outdoor Unit Inverter Compressor Drive IPM Fault
	2	2	1	Inverter Board Input Over Current(RMS) of Master Outdoor Unit	Master Outdoor Unit Inverter Board Input Current excess (RMS)
			2	Inverter Board Input Over Current(RMS) of Slave1 Outdoor Unit	Slave1 Outdoor Unit Inverter Board Input Current excess (RMS)
			3	Inverter Board Input Over Current(RMS) of Slave2 Outdoor Unit	Slave2 Outdoor Unit Inverter Board Input Current excess (RMS)
			4	Inverter Board Input Over Current(RMS) of Slave3 Outdoor Unit	Slave3 Outdoor Unit Inverter Board Input Current excess (RMS)

Self-diagnosis function

Display			Title	Cause of Error	
Outdoor unit related error	2	3	1	Master Outdoor Unit Inverter Compressor DC link Low Voltage1	DC charging is not performed at Master Outdoor Unit after starting relay turn on.
			2	Slave1 Outdoor Unit Inverter Compressor DC link Low Voltage	DC charging is not performed at Slave1 Outdoor Unit after starting relay turn on.
			3	Slave2 Outdoor Unit Inverter Compressor DC link Low Voltage	DC charging is not performed at Slave2 Outdoor Unit after starting relay turn on.
			4	Slave3 Outdoor Unit Inverter Compressor DC link Low Voltage	DC charging is not performed at Slave3 Outdoor Unit after starting relay turn on.
	2	4	1	Master Outdoor Unit High Pressure Switch	System is turned off by Master Outdoor Unit high pressure switch.
			2	Slave1 Outdoor Unit High Pressure Switch	System is turned off by slave1 Outdoor Unit high pressure switch.
			3	Slave2 Outdoor Unit High Pressure Switch	System is turned off by slave2 Outdoor Unit high pressure switch.
			4	Slave3 Outdoor Unit High Pressure Switch	System is turned off by slave3 Outdoor Unit high pressure switch.
	2	5	1	Master Outdoor Unit Input Voltage High/Low Voltage	Master Outdoor Unit input voltage is over 487V or below 270V
			2	Slave1 Outdoor Unit Input Voltage High/Low Voltage	Slave1 Outdoor Unit input voltage is over 487V or below 270V
			3	Slave2 Outdoor Unit Input Voltage High/Low Voltage	Slave2 Outdoor Unit input voltage is over 487V or below 270V
			4	Slave3 Outdoor Unit Input Voltage High/Low Voltage	Slave3 Outdoor Unit input voltage is over 487V or below 270V
	2	6	1	Master Outdoor Unit Inverter Compressor Start Failure	The First Start Failure by Master Outdoor Unit Inverter Compressor Abnormality
			2	Slave1 Outdoor Unit Inverter Compressor Start Failure	The First Start Failure by Slave1 Outdoor Unit Inverter Compressor Abnormality
			3	Slave2 Outdoor Unit Inverter Compressor Start Failure	The First Start Failure by Slave2 Outdoor Unit Inverter Compressor Abnormality
			4	Slave3 Outdoor Unit Inverter Compressor Start Failure	The First Start Failure by Slave3 Outdoor Unit Inverter Compressor Abnormality
	2	8	1	Master Outdoor Unit Inverter DC link High Voltage	System is turned off by Master Outdoor Unit DC Voltage Over Charging
			2	Slave1 Outdoor Unit Inverter DC link High Voltage	System is turned off by Slave1 Outdoor Unit DC Voltage Over Charging
			3	Slave2 Outdoor Unit Inverter DC link High Voltage	System is turned off by Slave2 Outdoor Unit DC Voltage Over Charging
			4	Slave3 Outdoor Unit Inverter DC link High Voltage	System is turned off by Slave3 Outdoor Unit DC Voltage Over Charging
2	9	1	Master Outdoor Unit Inverter Compressor Over Current	Master Outdoor Unit Inverter Compressor Fault OR Drive Fault	
		2	Slave1 Outdoor Unit Inverter Compressor Over Current	Slave1 Outdoor Unit Inverter Compressor Fault OR Drive Fault	
		3	Slave2 Outdoor Unit Inverter Compressor Over Current	Slave2 Outdoor Unit Inverter Compressor Fault OR Drive Fault	
		4	Slave3 Outdoor Unit Inverter Compressor Over Current	Slave3 Outdoor Unit Inverter Compressor Fault OR Drive Fault	

Display			Title	Cause of Error	
Outdoor unit related error	3	0	1	Master Outdoor Unit Constant Speed Compressor2 High Discharge Temperature	System is turned off by Master Outdoor Unit Constant Speed Compressor2 High Discharge Temperature
			2	Slave1 Outdoor Unit Constant Speed Compressor2 High Discharge Temperature	System is turned off by Slave1 Outdoor Unit Constant Speed Compressor2 High Discharge Temperature
			3	Slave2 Outdoor Unit Constant Speed Compressor2 High Discharge Temperature	System is turned off by Slave2 Outdoor Unit Constant Speed Compressor2 High Discharge Temperature
			4	Slave3 Outdoor Unit Constant Speed Compressor2 High Discharge Temperature	System is turned off by Slave3 Outdoor Unit Constant Speed Compressor2 High Discharge Temperature
	3	2	1	Master Outdoor Unit Inverter Compressor High Discharge Temperature	System is turned off by Master Outdoor Unit Inverter Compressor High Discharge Temperature
			2	Slave1 Outdoor Unit Inverter Compressor High Discharge Temperature	System is turned off by Slave1 Outdoor Unit Inverter Compressor High Discharge Temperature
			3	Slave2 Outdoor Unit Inverter Compressor Discharge High Temperature	System is turned off by Slave2 Outdoor Unit Inverter Compressor High Discharge Temperature
			4	Slave3 Outdoor Unit Inverter Compressor High Discharge Temperature	System is turned off by Slave3 Outdoor Unit Inverter Compressor High Discharge Temperature
	3	3	1	Master Outdoor Unit Constant Speed Compressor1 High Discharge Temperature	System is turned off by Master Outdoor Unit Constant Speed Compressor1 High Discharge Temperature
			2	Slave1 Outdoor Unit Constant Speed Compressor1 High Discharge Temperature	System is turned off by Slave1 Outdoor Unit Constant Speed Compressor1 High Discharge Temperature
			3	Slave2 Outdoor Unit Constant Speed Compressor1 High Discharge Temperature	System is turned off by Slave2 Outdoor Unit Constant Speed Compressor1 High Discharge Temperature
			4	Slave3 Outdoor Unit Constant Speed Compressor1 High Discharge Temperature	System is turned off by Slave3 Outdoor Unit Constant Speed Compressor1 High Discharge Temperature
	3	4	1	High Pressure of Master Outdoor Unit	System is turned off by excessive increase of high pressure of Master Outdoor Unit
			2	High Pressure of Slave1 Outdoor Unit	System is turned off by excessive increase of high pressure of Slave1 Outdoor Unit
			3	High Pressure of Slave2 Outdoor Unit	System is turned off by excessive increase of high pressure of Slave2 Outdoor Unit
			4	High Pressure of Slave3 Outdoor Unit	System is turned off by excessive increase of high pressure of Slave3 Outdoor Unit
	3	5	1	Low Pressure of Master Outdoor Unit	System is turned off by excessive decrease of low pressure of Master Outdoor Unit
			2	Low Pressure of Slave1 Outdoor Unit	System is turned off by excessive decrease of low pressure of Slave1 Outdoor Unit
			3	Low Pressure of Slave2 Outdoor Unit	System is turned off by excessive decrease of low pressure of Slave2 Outdoor Unit
			4	Low Pressure of Slave3 Outdoor Unit	System is turned off by excessive decrease of low pressure of Slave3 Outdoor Unit
3	6	1	Master Outdoor Unit Low Condensing Ratio Limited	Master Outdoor Unit stayed under low condensing limit for 3 minutes	
		2	Slave1 Outdoor Unit Low Condensing Ratio Limited	Slave1 Outdoor Unit stayed under low condensing limit for 3 minutes	
		3	Slave2 Outdoor Unit Low Condensing Ratio Limited	Slave2 Outdoor Unit stayed under low condensing limit for 3 minutes	
		4	Slave3 Outdoor Unit Low Condensing Ratio Limited	Slave3 Outdoor Unit stayed under low condensing limit for 3 minutes	

Self-diagnosis function

Display			Title	Cause of Error	
Outdoor unit related error	4	0	1	Master Outdoor Unit Inverter Compressor CT Sensor Fault	Master Outdoor Unit Inverter Compressor CT Sensor open or short
			2	Slave1 Outdoor Unit Inverter Compressor CT Sensor Fault	Slave1 Outdoor Unit Inverter Compressor CT Sensor open or short
			3	Slave2 Outdoor Unit Inverter Compressor CT Sensor Fault	Slave2 Outdoor Unit Inverter Compressor CT Sensor open or short
			4	Slave3 Outdoor Unit Inverter Compressor CT Sensor Fault	Slave3 Outdoor Unit Inverter Compressor CT Sensor open or short
	4	1	1	Master Outdoor Unit Inverter Compressor Discharge Temperature Sensor Fault	Master Outdoor Unit Inverter Compressor Discharge Temperature Sensor open or short
			2	Slave1 Outdoor Unit Inverter Compressor Discharge Temperature Sensor Fault	Slave1 Outdoor Unit Inverter Compressor Discharge Temperature Sensor open or short
			3	Slave2 Outdoor Unit Inverter Compressor Discharge Temperature Sensor Fault	Slave2 Outdoor Unit Inverter Compressor Discharge Temperature Sensor open or short
			4	Slave3 Outdoor Unit Inverter Compressor Discharge Temperature Sensor Fault	Slave3 Outdoor Unit Inverter Compressor Discharge Temperature Sensor open or short
	4	2	1	Master Outdoor Unit Low Pressure Sensor Fault	Master Outdoor Unit Low Pressure Sensor open or short
			2	Slave1 Outdoor Unit Low Pressure Sensor Fault	Slave1 Outdoor Unit Low Pressure Sensor open or short
			3	Slave2 Outdoor Unit Low Pressure Sensor Fault	Slave2 Outdoor Unit Low Pressure Sensor open or short
			4	Slave3 Outdoor Unit Low Pressure Sensor Fault	Slave3 Outdoor Unit Low Pressure Sensor open or short
	4	3	1	Master Outdoor Unit High Pressure Sensor Fault	Master Outdoor Unit High Pressure Sensor open or short
			2	Slave1 Outdoor Unit High Pressure Sensor Fault	Slave1 Outdoor Unit High Pressure Sensor open or short
			3	Slave2 Outdoor Unit High Pressure Sensor Fault	Slave2 Outdoor Unit High Pressure Sensor open or short
			4	Slave3 Outdoor Unit High Pressure Sensor Fault	Slave3 Outdoor Unit High Pressure Sensor open or short
	4	4	1	Master Outdoor Unit Air Temperature Sensor Fault	Master Outdoor Unit Air Temperature Sensor open or short
			2	Slave1 Outdoor Unit Air Temperature Sensor Fault	Slave1 Outdoor Unit Air Temperature Sensor open or short
			3	Slave2 Outdoor Unit Air Temperature Sensor Fault	Slave2 Outdoor Unit Air Temperature Sensor open or short
			4	Slave3 Outdoor Unit Air Temperature Sensor Fault	Slave3 Outdoor Unit Air Temperature Sensor open or short

Display			Title	Cause of Error	
Outdoor unit related error	4	5	1	Master Outdoor Unit Heat Exchanger Temperature Sensor (Front side) Fault	Master Outdoor Unit Heat Exchanger Temperature Sensor(Front side) open or short
			2	Slave1 Outdoor Unit Heat Exchanger Temperature Sensor (Front side) Fault	Slave1 Outdoor Unit Heat Exchanger Temperature Sensor (Front side) open or short
			3	Slave2 Outdoor Unit Heat Exchanger Temperature Sensor (Front side) Fault	Slave2 Outdoor Unit Heat Exchanger Temperature Sensor(Front side) open or short
			4	Slave3 Outdoor Unit Heat Exchanger Temperature Sensor (Front side) Fault	Slave3 Outdoor Unit Heat Exchanger Temperature Sensor(Front side) open or short
	4	6	1	Master Outdoor Unit Suction Temperature Sensor Fault	Master Outdoor Unit Suction Temperature Sensor open or short
			2	Slave1 Outdoor Unit Suction Temperature Sensor Fault	Slave1 Outdoor Unit Suction Temperature Sensor open or short
			3	Slave2 Outdoor Unit Suction Temperature Sensor Fault	Slave2 Outdoor Unit Suction Temperature Sensor open or short
			4	Slave3 Outdoor Unit Suction Temperature Sensor Fault	Slave3 Outdoor Unit Suction Temperature Sensor open or short
	4	7	1	Master Outdoor Unit Constant Speed Compressor1 Discharge Temperature Sensor Fault	Master Outdoor Unit Constant Speed Compressor1 Discharge Temperature Sensor open or short
			2	Slave1 Outdoor Unit Constant Speed Compressor1 Discharge Temperature Sensor Fault	Slave1 Outdoor Unit Constant Speed Compressor1 Discharge Temperature Sensor open or short
			3	Slave2 Outdoor Unit Constant Speed Compressor1 Discharge Temperature Sensor Fault	Slave2 Outdoor Unit Constant Speed Compressor1 Discharge Temperature Sensor open or short
			4	Slave3 Outdoor Unit Constant Speed Compressor1 Discharge Temperature Sensor Fault	Slave3 Outdoor Unit Constant Speed Compressor1 Discharge Temperature Sensor open or short
	4	8	1	Master Outdoor Unit Constant Speed Compressor2 Discharge Temperature Sensor Fault	Master Outdoor Unit Constant Speed Compressor 2 Discharge Temperature Sensor open or short
			2	Slave1 Outdoor Unit Constant Speed Compressor2 Discharge Temperature Sensor Fault	Slave1 Outdoor Unit Constant Speed Compressor 2 Discharge Temperature Sensor open or short
			3	Slave2 Outdoor Unit Constant Speed Compressor2 Discharge Temperature Sensor Fault	Slave2 Outdoor Unit Constant Speed Compressor 2 Discharge Temperature Sensor open or short
			4	Slave3 Outdoor Unit Constant Speed Compressor2 Discharge Temperature Sensor Fault	Slave3 Outdoor Unit Constant Speed Compressor 2 Discharge Temperature Sensor open or short
4	9	1	Master Outdoor Unit Faulty IPM Temperature Sensor	Master Outdoor Unit IPM Temperature Sensor short/open	
		2	Slave1 Outdoor Unit Faulty IPM Temperature Sensor	Slave1 Outdoor Unit IPM Temperature Sensor short/open	
		3	Slave2 Outdoor Unit Faulty IPM Temperature Sensor	Slave2 Outdoor Unit IPM Temperature Sensor short/open	
		4	Slave3 Outdoor Unit Faulty IPM Temperature Sensor	Slave3 Outdoor Unit IPM Temperature Sensor short/open	

Self-diagnosis function

Display			Title	Cause of Error	
Outdoor unit related error	5	0	1	Omitting connection of R, S, T power of Master Outdoor Unit	Omitting connection of Master outdoor unit
			2	Omitting connection of R, S, T power of Slave1 Outdoor Unit	Omitting connection of Slave1 Outdoor Unit
			3	Omitting connection of R, S, T power of Slave2 Outdoor Unit	Omitting connection of Slave2 Outdoor Unit
			4	Omitting connection of R, S, T power of Slave3 Outdoor Unit	Omitting connection of Slave3 Outdoor Unit
	5	1	1	Excessive capacity of indoor units	Excessive connection of indoor units compared to capacity of Outdoor Unit
	5	2	1	Communication error : inverter PCB → Main PCB	Failing to receive inverter signal at main PCB of Master Outdoor Unit
			2	Communication error : inverter PCB → Main PCB	Failing to receive inverter signal at main PCB of Slave1 Outdoor Unit
			3	Communication error : inverter PCB → Main PCB	Failing to receive inverter signal at main PCB of Slave2 Outdoor Unit
			4	Communication error : inverter PCB → Main PCB	Failing to receive inverter signal at main PCB of Slave3 Outdoor Unit
	5	3	1	Communication error : indoor unit → main PCB of Outdoor Unit	Failing to receive indoor unit signal at main PCB of Outdoor Unit .
	5	4	1	Reverse connection of R, S, T power of Master Outdoor Unit	Reverse connection or omitting connection of R, S, T power of Master Outdoor Unit
			2	Reverse connection of R, S, T power of Slave1 Outdoor Unit	Reverse connection or omitting connection of R, S, T power of Slave1 Outdoor Unit
			3	Reverse connection of R, S, T power of Slave2 Outdoor Unit	Reverse connection or omitting connection of R, S, T power of Slave2 Outdoor Unit
			4	Reverse connection of R, S, T power of Slave3 Outdoor Unit	Reverse connection or omitting connection of R, S, T power of Slave3 Outdoor Unit
	5	7	1	Master Outdoor Unit Communication Error with Inverter Controller	Master Outdoor Unit Controller part cannot receive inverter control signals (usually happens after on-boarding)
			2	Slave1 Outdoor Unit Communication Error with Inverter Controller	Slave1 Outdoor Unit Controller part cannot receive inverter control signals (usually happens after on-boarding)
			3	Slave2 Outdoor Unit Communication Error with Inverter Controller	Slave2 Outdoor Unit Controller part cannot receive inverter control signals (usually happens after on-boarding)
			4	Slave3 Outdoor Unit Communication Error with Inverter Controller	Slave3 Outdoor Unit Controller part cannot receive inverter control signals (usually happens after on-boarding)
	5	9	1	Mixing Installation of Sub Outdoor Unit	Mixing Installation of Old Sub Outdoor Unit and New Slave Outdoor Unit

Display			Title	Cause of Error	
Outdoor unit related error	6	0	1	Inverter PCB EEPROM Error of Master Outdoor Unit	Access Error of Inverter PCB of Master Outdoor Unit
			2	Inverter PCB EEPROM Error of Slave1 Unit	Access Error of Inverter PCB of Slave1 Outdoor Unit
			3	Inverter PCB EEPROM Error of Slave2 Unit	Access Error of Inverter PCB of Slave2 Outdoor Unit
			4	Inverter PCB EEPROM Error of Slave3 Unit	Access Error of Inverter PCB of Slave3 Outdoor Unit
	6	7	1	Master Outdoor Unit Fan Lock	Restriction of Master Outdoor Unit
			2	Slave1 Outdoor Unit Fan Lock	Restriction of Slave1 Outdoor Unit
			3	Slave2 Outdoor Unit Fan Lock	Restriction of Slave2 Outdoor Unit
			4	Slave3 Outdoor Unit Fan Lock	Restriction of Slave3 Outdoor Unit
	6	9	1	Constant1 CT Sensor Error of Master Outdoor Unit	Constant1 CT Sensor open or short of Master Outdoor Unit
			2	Constant1 CT Sensor Error of Slave1 Outdoor Unit	Constant1 CT Sensor open or short of Slave1 Outdoor Unit
			3	Constant1 CT Sensor Error of Slave2 Outdoor Unit	Constant1 CT Sensor open or short of Slave2 Outdoor Unit
			4	Constant1 CT Sensor Error of Slave3 Outdoor Unit	Constant1 CT Sensor open or short of Slave3 Outdoor Unit
	7	0	1	Constant2 CT Sensor Error of Master Outdoor Unit	Constant2 CT Sensor open or short of Master Outdoor Unit
			2	Constant2 CT Sensor Error of Slave1 Outdoor Unit	Constant2 CT Sensor open or short of Slave1 Outdoor Unit
			3	Constant2 CT Sensor Error of Slave2 Outdoor Unit	Constant2 CT Sensor open or short of Slave2 Outdoor Unit
			4	Constant2 CT Sensor Error of Slave3 Outdoor Unit	Constant2 CT Sensor open or short of Slave3 Outdoor Unit
	7	3	1	Instant Over Current(Peak) of Master Outdoor Unit PFC	Instant Over Current(Peak) of Master Outdoor Unit PFC
			2	Instant Over Current(Peak) of Slave1 Outdoor Unit PFC	Instant Over Current(Peak) of Slave1 Outdoor Unit PFC
			3	Instant Over Current(Peak) of Slave2 Outdoor Unit PFC	Instant Over Current(Peak) of Slave2 Outdoor Unit PFC
			4	Instant Over Current(Peak) of Slave3 Outdoor Unit PFC	Instant Over Current(Peak) of Slave3 Outdoor Unit PFC
7	5	1	Master Outdoor Unit Fan CT Sensor Error	Master Outdoor Unit Fan CT Sensor open or short	
		2	Slave1 Outdoor Unit Fan CT Sensor Error	Slave1 Outdoor Unit Fan CT Sensor open or short	
		3	Slave2 Outdoor Unit Fan CT Sensor Error	Slave2 Outdoor Unit Fan CT Sensor open or short	
		4	Slave3 Outdoor Unit Fan CT Sensor Error	Slave3 Outdoor Unit Fan CT Sensor open or short	

Self-diagnosis function

Display			Title	Cause of Error	
Outdoor unit related error	7	6	1	Master Outdoor Unit Fan DC Link High Voltage Error	Master Outdoor Unit Fan DC Link High Voltage Error
			2	Slave1 Outdoor Unit Fan DC Link High Voltage Error	Slave1 Outdoor Unit Fan DC Link High Voltage Error
			3	Slave2 Outdoor Unit Fan DC Link High Voltage Error	Slave2 Outdoor Unit Fan DC Link High Voltage Error
			4	Slave3 Outdoor Unit Fan DC Link High Voltage Error	Slave3 Outdoor Unit Fan DC Link High Voltage Error
	7	7	1	Master Outdoor Unit Fan Over Current Error	Master Outdoor Unit Fan Current is over 5A
			2	Slave1 Outdoor Unit Fan Over Current Error	Slave1 Outdoor Unit Fan is over 5A
			3	Slave2 Outdoor Unit Fan Over Current Error	Slave2 Outdoor Unit Fan is over 5A
			4	Slave3 Outdoor Unit Fan Over Current Error	Slave3 Outdoor Unit Fan is over 5A
	7	9	1	Master Outdoor Unit Fan Start Failure Error	Master Outdoor Unit Fan First Position Sensing Failure
			2	Slave1 Outdoor Unit Fan Start Failure Error	Slave1 Outdoor Unit Fan First Position Sensing Failure
			3	Slave2 Outdoor Unit Fan Start Failure Error	Slave2 Outdoor Unit Fan First Position Sensing Failure
			4	Slave3 Outdoor Unit Fan Start Failure Error	Slave3 Outdoor Unit Fan First Position Sensing Failure
	8	6	1	Master Outdoor Unit Main PCB EEPROM Error	Communication Fail Between Master Outdoor Unit Main MICOM and EEPROM or omitting EEPROM
			2	Slave1 Outdoor Unit Main PCB EEPROM Error	Communication Fail Between Slave1 Outdoor Unit Main MICOM and EEPROM or omitting EEPROM
			3	Slave2 Outdoor Unit Main PCB EEPROM Error	Communication Fail Between Slave2 Outdoor Unit Main MICOM and EEPROM or omitting EEPROM
			4	Slave3 Outdoor Unit Main PCB EEPROM Error	Communication Fail Between Slave3 Outdoor Unit Main MICOM and EEPROM or omitting EEPROM
8	7	1	Master Outdoor Unit Fan PCB EEPROM Error	Communication Fail Between Master Outdoor Unit Fan MICOM and EEPROM or omitting EEPROM	
		2	Slave1 Outdoor Unit Fan PCB EEPROM Error	Communication Fail Between Slave1 Outdoor Unit Fan MICOM and EEPROM or omitting EEPROM	
		3	Slave2 Outdoor Unit Fan PCB EEPROM Error	Communication Fail Between Slave2 Outdoor Unit Fan MICOM and EEPROM or omitting EEPROM	
		4	Slave3 Outdoor Unit Fan PCB EEPROM Error	Communication Fail Between Slave3 Outdoor Unit Fan MICOM and EEPROM or omitting EEPROM	

Display				Title	Cause of Error	
Outdoor unit related error	1	0	4	1	Communication Error Between Master Outdoor Unit and Other Outdoor Unit	Failing to receive Slave Unit signal at main PCB of Master Outdoor Unit
				2	Communication Error Between Slave1 Outdoor Unit and Other Outdoor Unit	Failing to receive master and other Slave Unit signal at main PCB of Slave1 Outdoor Unit
				3	Communication Error Between Slave2 Outdoor Unit and Other Outdoor Unit	Failing to receive master and other Slave Unit signal at main PCB of Slave2 Outdoor Unit
				4	Communication Error Between Slave3 Outdoor Unit and Other Outdoor Unit	Failing to receive master and other Slave Unit signal at main PCB of Slave3 Outdoor Unit
	1	0	5	1	Master Outdoor Unit Fan PCB Communication Error	Failing to receive fan signal at main PCB of master unit.
				2	Slave1 Outdoor Unit Fan PCB Communication Error	Failing to receive fan signal at main PCB of Slave1 unit.
				3	Slave2 Outdoor Unit Fan PCB Communication Error	Failing to receive fan signal at main PCB of Slave2 unit.
				4	Slave3 Outdoor Unit Fan PCB Communication Error	Failing to receive fan signal at main PCB of Slave3 unit.
	1	0	6	1	Master Outdoor Unit FAN IPM Fault Error	Instant Over Current at Master Outdoor Unit Fan IPM
				2	Slave1 Outdoor Unit FAN IPM Fault Error	Instant Over Current at Slave1 Outdoor Unit Fan IPM
				3	Slave2 Outdoor Unit FAN IPM Fault Error	Instant Over Current at Slave2 Outdoor Unit Fan IPM
				4	Slave3 Outdoor Unit FAN IPM Fault Error	Instant Over Current at Slave3 Outdoor Unit Fan IPM
	1	0	7	1	Master Outdoor Unit Fan DC Link Low Voltage Error	Master Outdoor Unit Fan DC Link Input Voltage is under 380V
				2	Slave1 Outdoor Unit Fan DC Link Low Voltage Error	Slave1 Outdoor Unit Fan DC Link Input Voltage is under 380V
				3	Slave2 Outdoor Unit Fan DC Link Low Voltage Error	Slave2 Outdoor Unit Fan DC Link Input Voltage is under 380V
				4	Slave3 Outdoor Unit Fan DC Link Low Voltage Error	Slave3 Outdoor Uni Fan DC Link Input Voltage is under 380V
1	1	3	1	Master Outdoor Unit Liquid pipe Temperature Sensor Error	Liquid pipe temperature sensor of Master Outdoor Unit is open or short	
			2	Slave1 Outdoor Unit Liquid pipe Temperature Sensor Error	Liquid pipe temperature sensor of slave1 Outdoor Unit is open or short	
			3	Slave2 Outdoor Unit Liquid pipe Temperature Sensor Error	Liquid pipe temperature sensor of slave2 Outdoor Unit is open or short	
			4	Slave3 Outdoor Unit Liquid pipe Temperature Sensor Error	Liquid pipe temperature sensor of slave3 Outdoor Unit is open or short	

Self-diagnosis function

Display				Title	Cause of Error	
Outdoor unit related error	1	1	5	1	Master Outdoor Unit Subcooling Outlet Temperature Sensor Error	Master Outdoor Unit Subcooling Outlet Temperature Sensor open or short
				2	Slave1 Outdoor Unit Subcooling Outlet Temperature Sensor Error	Slave1 Outdoor Unit Subcooling Outlet Temperature Sensor open or short
				3	Slave2 Outdoor Unit Subcooling Outlet Temperature Sensor Error	Slave2 Outdoor Unit Subcooling Outlet Temperature Sensor open or short
				4	Slave3 Outdoor Unit Subcooling Outlet Temperature Sensor Error	Slave3 Outdoor Unit Subcooling Outlet Temperature Sensor open or short
	1	5	1	1	Failure of operation mode conversion at Master Outdoor Unit	Pressure unbalance between Outdoor Units
				2	Failure of operation mode conversion at Slave1 Outdoor Unit	Pressure unbalance between Outdoor Units
				3	Failure of operation mode conversion at Slave2 Outdoor Unit	Pressure unbalance between Outdoor Units
				4	Failure of operation mode conversion at Slave3 Outdoor Unit	Pressure unbalance between Outdoor Units
	1	5	3	1	Master upper part heat exchanger temperature sensor error	Master Outdoor Unit upper part temperature sensor open/short
				2	Slave1 upper part heat exchanger temperature sensor error	Slave1 Outdoor Unit upper part temperature sensor open/short
				3	Slave2 upper part heat exchanger temperature sensor error	Slave2 Outdoor Unit upper part temperature sensor open/short
				4	Slave3 upper part heat exchanger temperature sensor error	Slave3 Outdoor Unit upper part temperature sensor open/short
	1	5	4	1	Master lower part heat exchanger temperature sensor error	Master Outdoor Unit lower part temperature sensor open/short
				2	Slave1 lower part heat exchanger temperature sensor error	Slave1 Outdoor Unit lower part temperature sensor open/short
				3	Slave2 lower part heat exchanger temperature sensor error	Slave2 Outdoor Unit lower part temperature sensor open/short
				4	Slave3 lower part heat exchanger temperature sensor error	Slave3 Outdoor Unit lower part temperature sensor open/short
	1	7	3	1	Master Outdoor Unit Constant Speed Compressor Fault	Comp locking, Check Valve leakage, comp dielectric break down at Master Outdoor Unit
				2	Slave1 Outdoor Unit Constant Speed Compressor Fault	Comp locking, Check Valve leakage, comp dielectric at Slave1 Outdoor Unit
				3	Slave2 Outdoor Unit Constant Speed Compressor Fault	Comp locking, Check Valve leakage, comp dielectric at Slave2 Outdoor Unit
				4	Slave3 Outdoor Unit Constant Speed Compressor Fault	Comp locking, Check Valve leakage, comp dielectric at Slave3 Outdoor Unit
1	7	4	1	Master outdoor unit rated speed 2 condenser over-current	Master Outdoor Unit rated speed 2 condenser burned / locked or fault by over-current	
			2	Slave1 outdoor unit rated speed 2 condenser over-current	Slave1 Outdoor Unit rated speed 2 condenser burned / locked or fault by over-current	
			3	Slave2 outdoor unit rated speed 2 condenser over-current	Slave2 Outdoor Unit rated speed 2 condenser burned / locked or fault by over-current	
			4	Slave3 outdoor unit rated speed 2 condenser over-current	Slave3 Outdoor Unit rated speed 2 condenser burned / locked or fault by over-current	

			Display	Title	Cause of Error	
Outdoor unit related error	1	8	2	1	Master outdoor unit Main Board Main-Sub Micom communication error	Master Outdoor Unit Main Board Main-Sub Micom communication failed
				2	Slave1 outdoor unit Main Board Main-Sub Micom communication error	Slave1 Outdoor Unit Main Board Main-Sub Micom communication failed
				3	Slave2 outdoor unit Main Board Main-Sub Micom communication error	Slave2 Outdoor Unit Main Board Main-Sub Micom communication failed
				4	Slave3 outdoor unit Main Board Main-Sub Micom communication error	Slave3 Outdoor Unit Main Board Main-Sub Micom communication failed
	1	8	4	1	Master Inv. oil balance pipe Temperature Sensor error	Master Outdoor Unit oil balance temperature Sensor open or short
				2	Slave1 Inv. oil balance pipe Temperature Sensor error	Slave1 Outdoor Unit oil balance temperature Sensor open or short
				3	Slave2 Inv. oil balance pipe Temperature Sensor error	Slave2 Outdoor Unit oil balance temperature Sensor open or short
				4	Slave3 Inv. oil balance pipe Temperature Sensor error	Slave3 Outdoor Unit oil balance temperature Sensor open or short
	1	8	5	1	Master const.1 oil balance pipe Temperature Sensor error	Master Outdoor Unit oil balance temperature Sensor open or short
				2	Slave1 const.1 oil balance pipe Temperature Sensor error	Slave1 Outdoor Unit oil balance temperature Sensor open or short
				3	Slave2 const.1 oil balance pipe Temperature Sensor error	Slave2 Outdoor Unit oil balance temperature Sensor open or short
				4	Slave3 const.1 oil balance pipe Temperature Sensor error	Slave3 Outdoor Unit oil balance temperature Sensor open or short
	1	8	6	1	Master const.2 oil balance pipe Temperature Sensor error	Master Outdoor Unit oil balance temperature Sensor open or short
				2	Slave1 const.2 oil balance pipe Temperature Sensor error	Slave1 Outdoor Unit oil balance temperature Sensor open or short
				3	Slave2 const.2 oil balance pipe Temperature Sensor error	Slave2 Outdoor Unit oil balance temperature Sensor open or short
				4	Slave3 const.2 oil balance pipe Temperature Sensor error	Slave3 Outdoor Unit oil balance temperature Sensor open or short
	1	9	3	1	Excessive increase of Master Outdoor Unit Fan PCB Heat Sink Temperature	Master Outdoor Unit Fan Inverter PCB Temperature is Over 95°C
				2	Excessive increase of Slave1 Outdoor Unit Fan PCB Heat Sink Temperature	Slave1 Outdoor Unit Fan Inverter PCB Temperature is Over 95°C
				3	Excessive increase of Slave2 Outdoor Unit Fan PCB Heat Sink Temperature	Slave2 Outdoor Unit Fan Inverter PCB Temperature is Over 95°C
				4	Excessive increase of Slave3 Outdoor Unit Fan PCB Heat Sink Temperature	Slave3 Outdoor Unit Fan Inverter PCB Temperature is Over 95°C
1	9	4	1	Master Outdoor Unit Fan PCB Heat Sink Temperature Sensor Error	Master Outdoor Unit Fan PCB Heat Sink Temperature Sensor open or short	
			2	Slave1 Outdoor Unit Fan PCB Heat Sink Temperature Sensor Error	Slave1 Outdoor Unit Fan PCB Heat Sink Temperature Sensor open or short	
			3	Slave2 Outdoor Unit Fan PCB Heat Sink Temperature Sensor Error	Slave2 Outdoor Unit Fan PCB Heat Sink Temperature Sensor open or short	
			4	Slave3 Outdoor Unit Fan PCB Heat Sink Temperature Sensor Error	Slave3 Outdoor Unit Fan PCB Heat Sink Temperature Sensor open or short	

Troubleshooting Guide

Error No.	Error Type	Error Point	Main Reasons
01	Indoor unit air sensor error	Indoor unit sensor is open/short	1. Indoor unit PCB wrong connection 2. Indoor unit PCB failure 3. Sensor problem (main reason)
02	Indoor unit pipe inlet sensor error		
06	Indoor unit pipe outlet sensor error		

■ Error diagnosis and countermeasure flow chart

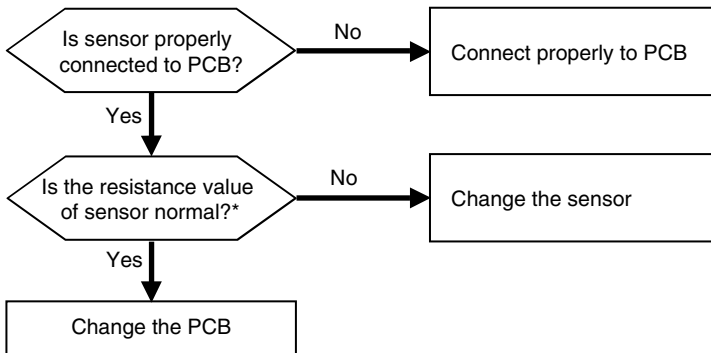

** In case the value is more than 100kΩ (open) or less than 100Ω (short), Error occurs

Refer: Resistance value maybe change according to temperature of temp sensor,
It shows according to criteria of current temperature(±5% margin) → Normal
Air temp sensor: 10°C = 20.7kΩ : 25°C= 10kΩ : 50°C= 3.4kΩ
Pipe temp sensor: 10°C = 10kΩ : 25°C= 5kΩ : 50°C= 1.8kΩ



← **CN-ROOM** : Indoor air temp sensor
← **CN-PIPE2** : Pipe outlet temp sensor
← **CN-PIPE1** : Pipe inlet temp sensor



← Measure the resistance of outlet pipe temp sensor.

Error No.	Error Type	Error Point	Main Reasons
03	No communication between cabled remote controller & indoor unit	The remote controller did not receive the signal from indoor unit during specific time	1. Remote controller fault 2. Indoor unit PCB fault 3. Connector fault, Wrong connection 4. Communication cable problem

■ Error diagnosis and countermeasure flow chart

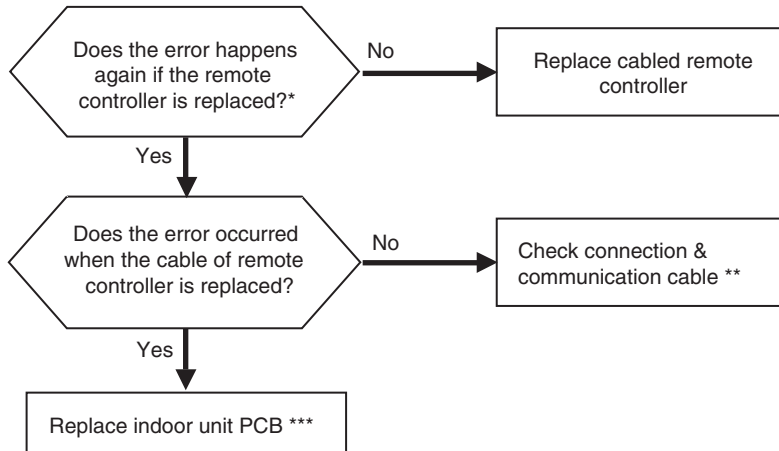

* If there is no remote controller to replace : Use another unit's remote controller doing well

** Check cable : Contact failure of connected portion or extension of cable are main cause
 Check any surrounded noise (check the distance with main power cable)
 → make safe distance from the devices generate electromagnetic wave

*** After replacing indoor unit PCB, do Auto Addressing & input unit's address if connected to central controller.
 (All the indoor units connected should be turned on before Auto Addressing)



← **CN-REMO** : Remote controller connection

※ The PCB can differ from model to model.
 Check from the right source.



← Checking communication cable connection status

Error No.	Error Type	Error Point	Main Reasons
04	Drain pump error	Float switch is open due to rising of condensate water level because of drain pump fault or drain pipe clogging	1. Drain pump/float switch fault 2. Improper drain pipe location, clogging of drain pipe 3. Indoor unit PCB fault

■ Error diagnosis and countermeasure flow chart

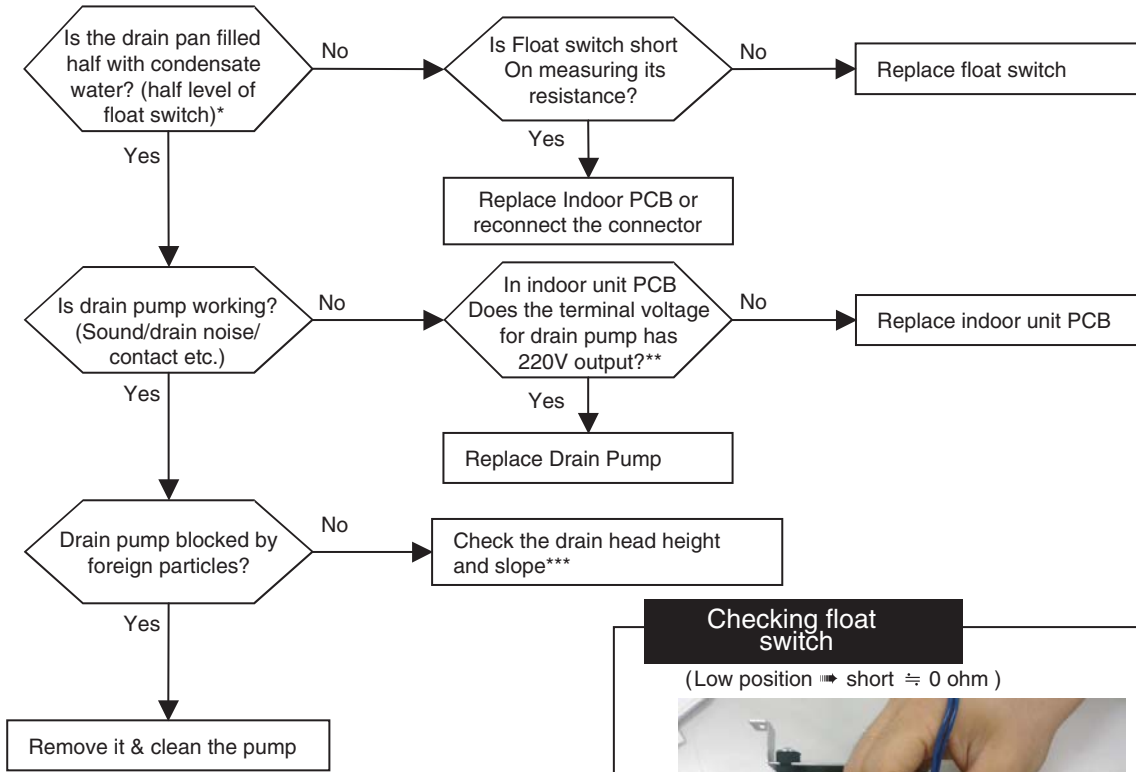

* If the float goes up higher than a half of float switch then the circuit is open & the unit is stopped automatically.



float

Condensate water

Checking float switch

(Low position → short ≈ 0 ohm)

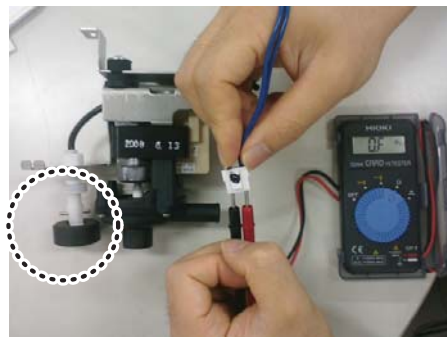

(High position → Open)

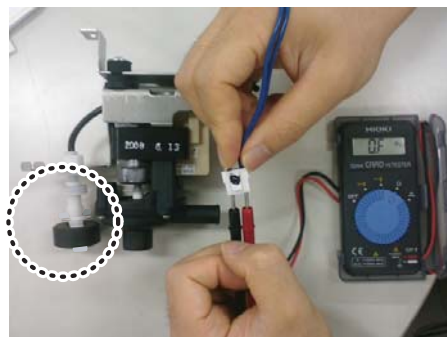



A:Point to check rotating

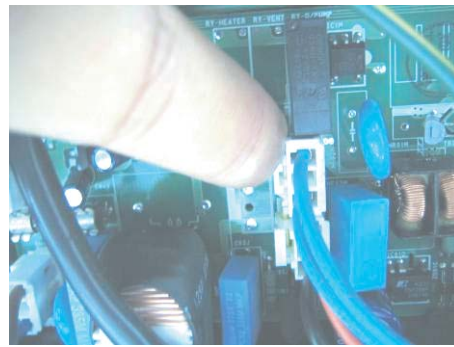

*** Indoor PCB drain pump connector
(Check input of 220V)
(Marked as **CN-DPUMP**)

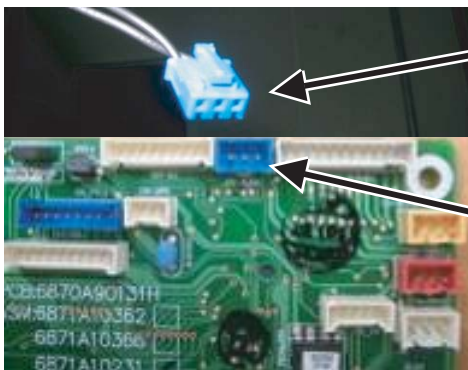

Float switch connector

Float switch Housing (**CN-FLOAT**)

[***] Standard of drain pipe head height / slope

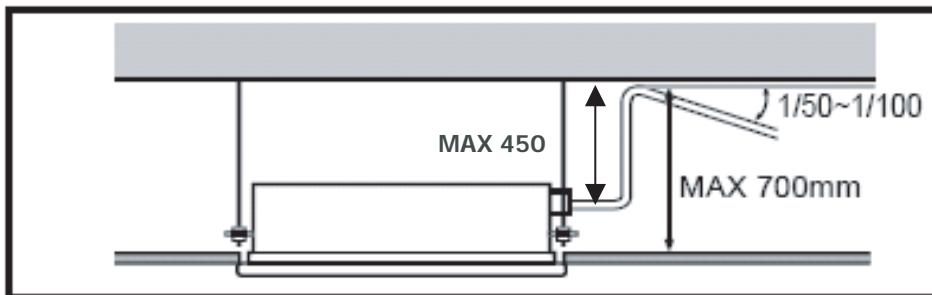

Error No.	Error Type	Error Point	Main Reasons
05	Indoor & Outdoor unit communication error	No signal communication between indoor & outdoor units.	1. Auto addressing is not done 2. Communication cable is not connected 3. Short circuit of communication cable 4. Indoor unit communication circuit fault 5. Outdoor unit communication circuit fault 6. Not enough distance between power and communication cable?

■ Error diagnosis and countermeasure flow chart

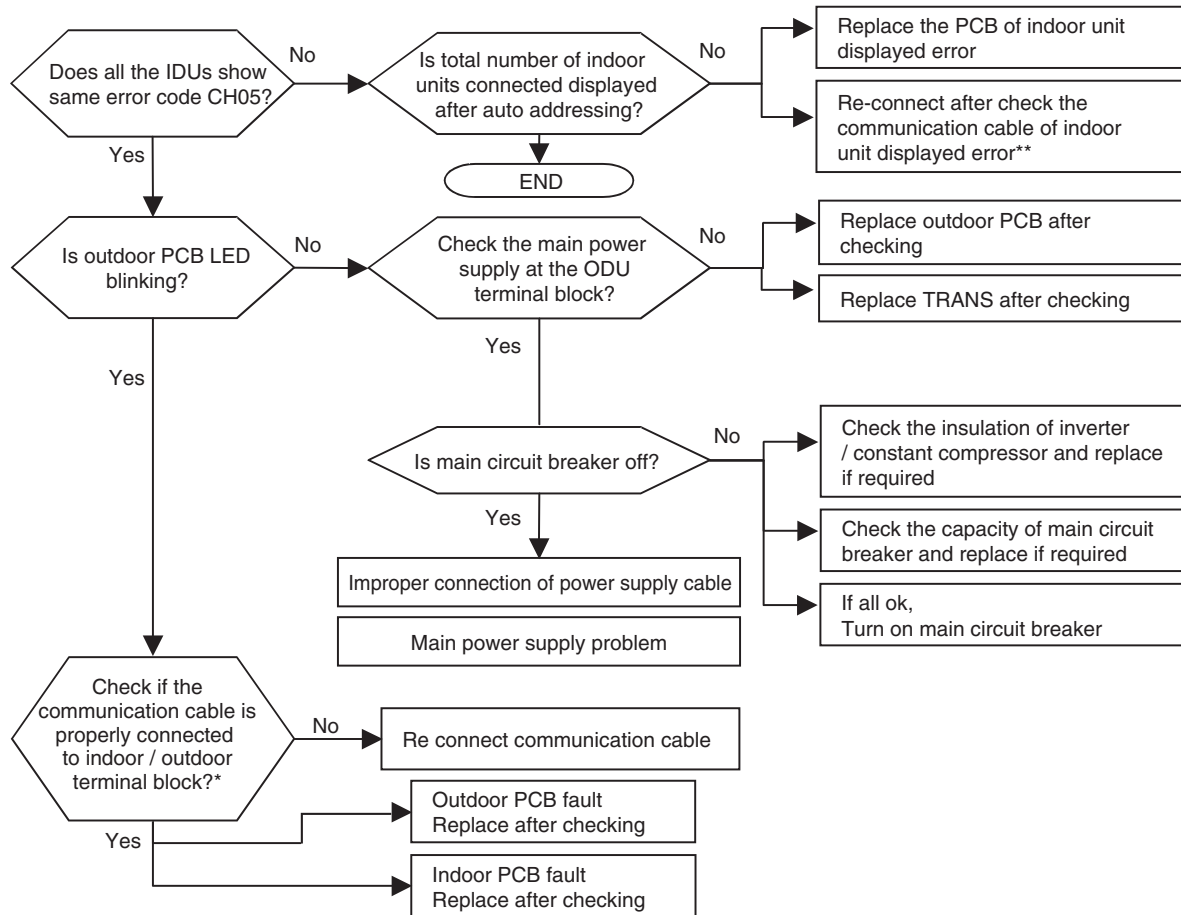

* (Note1) communication from IDU is normal if voltage fluctuation(-9V ~ +9V) exists when checking DC voltage of communication terminal between IDU and ODU

* If the DC voltage between communication terminal A, B of indoor unit is fluctuate within (-9V~+9V) then communication from outdoor unit is normal

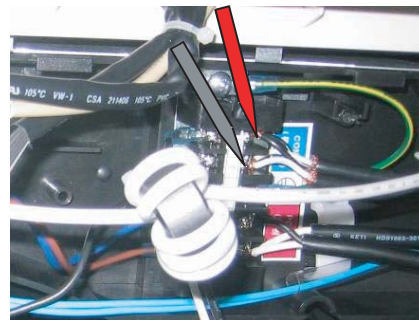

Error No.	Error Type	Error Point	Main Reasons
06	Indoor unit outlet pipe temperature sensor error	Indoor unit outlet pipe temperature sensor open or short	Refer to CH02

Error No.	Error Type	Error Point	Main Reasons
07	All Indoor units are not running in same mode	The Indoor units started later are operated in different mode from earlier one.	1. Indoor units are in different mode 2. PCB fault 3. cabled remote controller fault * Checking ch07 method IDU doesn't operate as Operation mode is flickering at IDU wired remote controller and IDU display window.

■ Error diagnosis and countermeasure flow chart

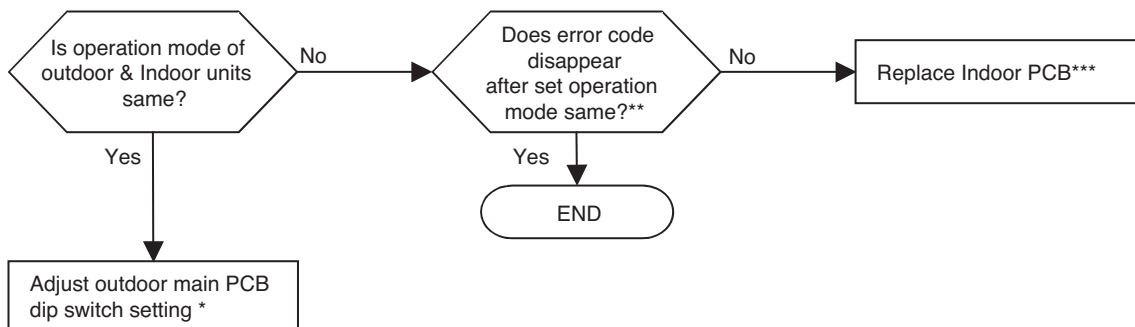

* Check mode selection setting of wired remote controller.

** Outdoor main PCB dip switch no.5 (Cooling) or no.6 (heating) is in On, different mode operation error may occur because the operation mode is fixed by dip switch setting.

*** Dissolution method CH07 with remote controller

- 1) Error removal method : Turn off remote controller by pressing the On/Off button on the cabled remote controller. The error code will be removed automatically after few seconds.
 With cableless remote controller: Turn off indoor unit, and then turn on by changing the operation mode. The error will disappear.

**** After replacing the indoor unit PCB, make sure to be done to do Auto addressing and input the address of central control

***** If ODU Dry Contact function is set , different mode operation error may be occurred because the operation mode is fixed.

Error No.	Error Type	Error Point	Main Reasons
09	Indoor unit EEPROM error		1. Error developed in communication between the micro-processor and the EEPROM on the surface of the PCB. 2. ERROR due to the EEPROM damage

■ **Error diagnosis and countermeasure flow chart**

- Replace the indoor unit PCB, and then make sure to perform Auto addressing and input the address of central control

Error No.	Error Type	Error Point	Main Reasons
10	Indoor unit BLDC fan motor failure	Indoor BLDC fan motor feedback signal is absent (for 50 sec.)	1. Motor connector connection fault 2. Indoor PCB fault 3. Motor fault

■ Error diagnosis and countermeasure flow chart

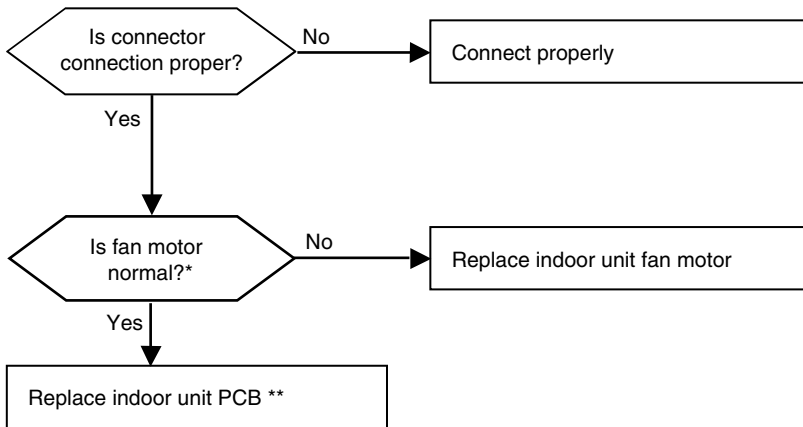

* It is normal when check hall sensor of indoor fan motor as shown below

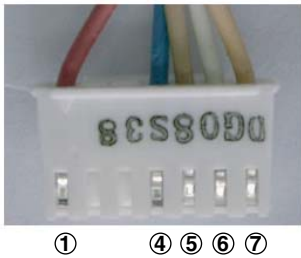

Each terminal with the tester

Tester		Normal resistance(±10%)	
+	-	TH chassis	TD chassis
①	④	∞	∞
⑤	④	hundreds kΩ	hundreds kΩ
⑥	④	∞	∞
⑦	④	hundreds kΩ	hundreds kΩ

<Checking connection state of fan motor connector>

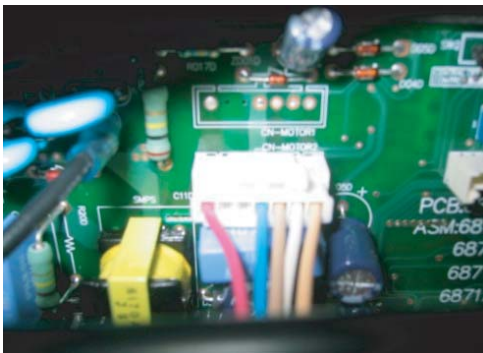

** Replace the indoor unit PCB, and then make sure to do Auto addressing and input the address of central control
(Notice: The connection of motor connector to PCB should be done under no power supplying to PCB)

Error No.	Error Type	Error Point	Main Reasons
21*	Inverter PCB Assy IPM Fault occur	IPM self protection circuit activation (Overcurrent/IPM overheating/Vcc low voltage)	1.Over current detection at Inverter compressor(U,V,W)
Master 211			2.Compressor damaged (insulation damaged/Motor damaged)
Slave1 212			3.IPM overheating (Heat sink fan damaged/Heat sink fan connector disconnected/Heat sink disassembled)
Slave2 213			4.Inverter compressor terminal disconnected or loose
Slave3 214			5.Inverter PCB assembly damaged 6.ODU input current low

■ Error diagnosis and countermeasure flow chart

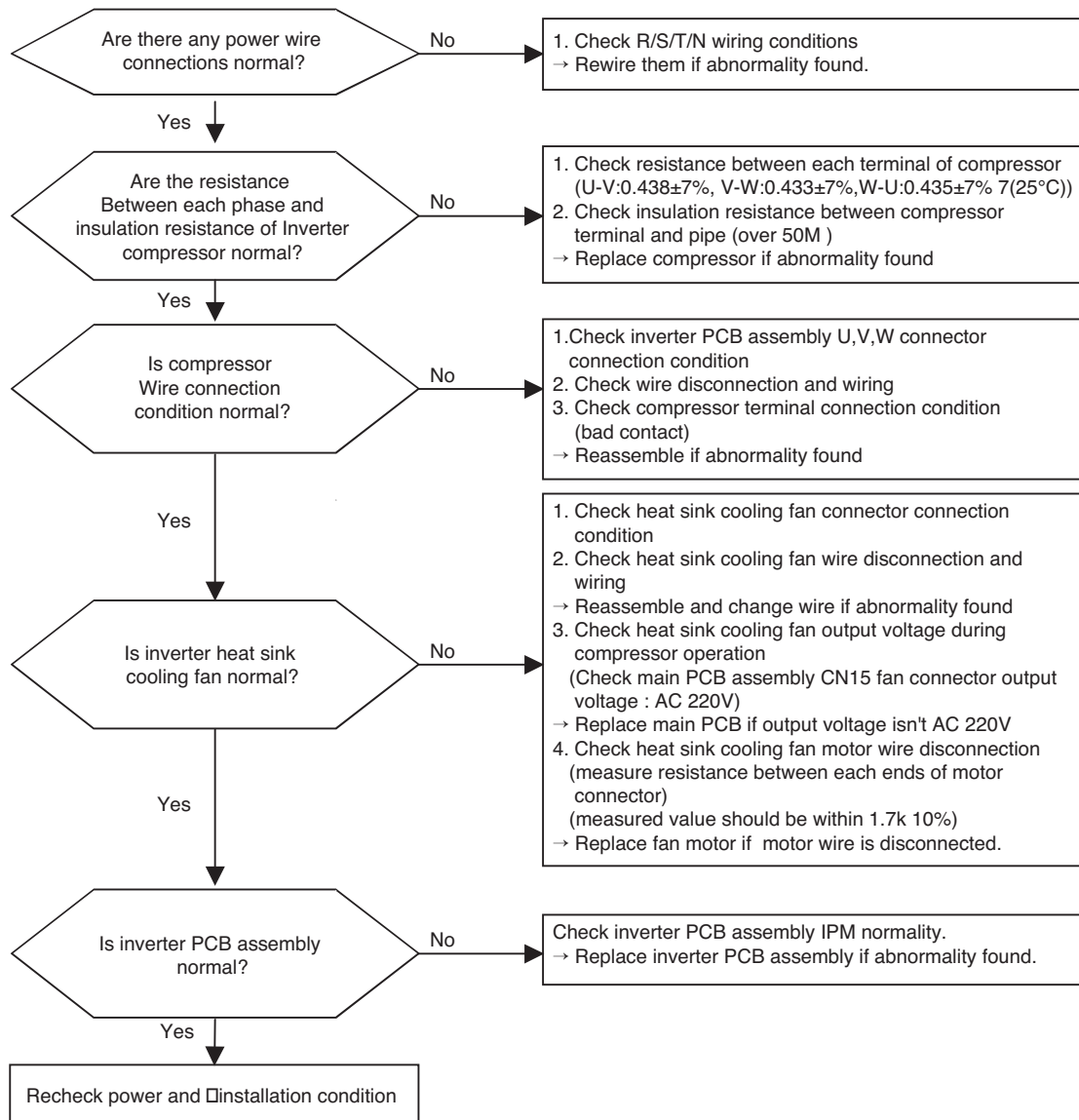

* Measuring resistance between each terminal of compressor



* Compressor wire connector connection point

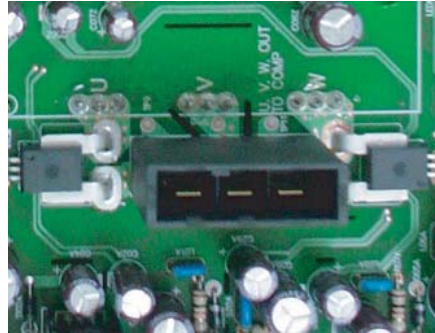

* IPM joining point

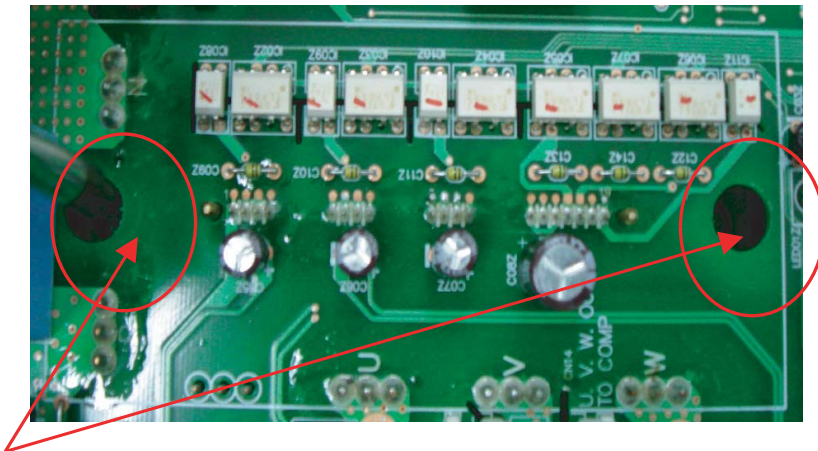

Check joining conditon

Error No.	Error Type	Error Point	Main Reasons
22* Master 221 Slave1 222 Slave2 223 Slave3 224	AC Input Current Over Error	Inverter PCB Assembly input 3 phase power current is over limited value(22A)	<ol style="list-style-type: none"> 1. Overload operation (Pipe clogging/Covering/EEV defect/Ref. overcharge) 2. Compressor damage(Insulation damage/Motor damage) 3. Input voltage low 4. Power Line Misconnection 5. Inverter PCB Assembly damage (Input current sensing part)

■ Error Diagnosis and Countermeasure Flow Chart

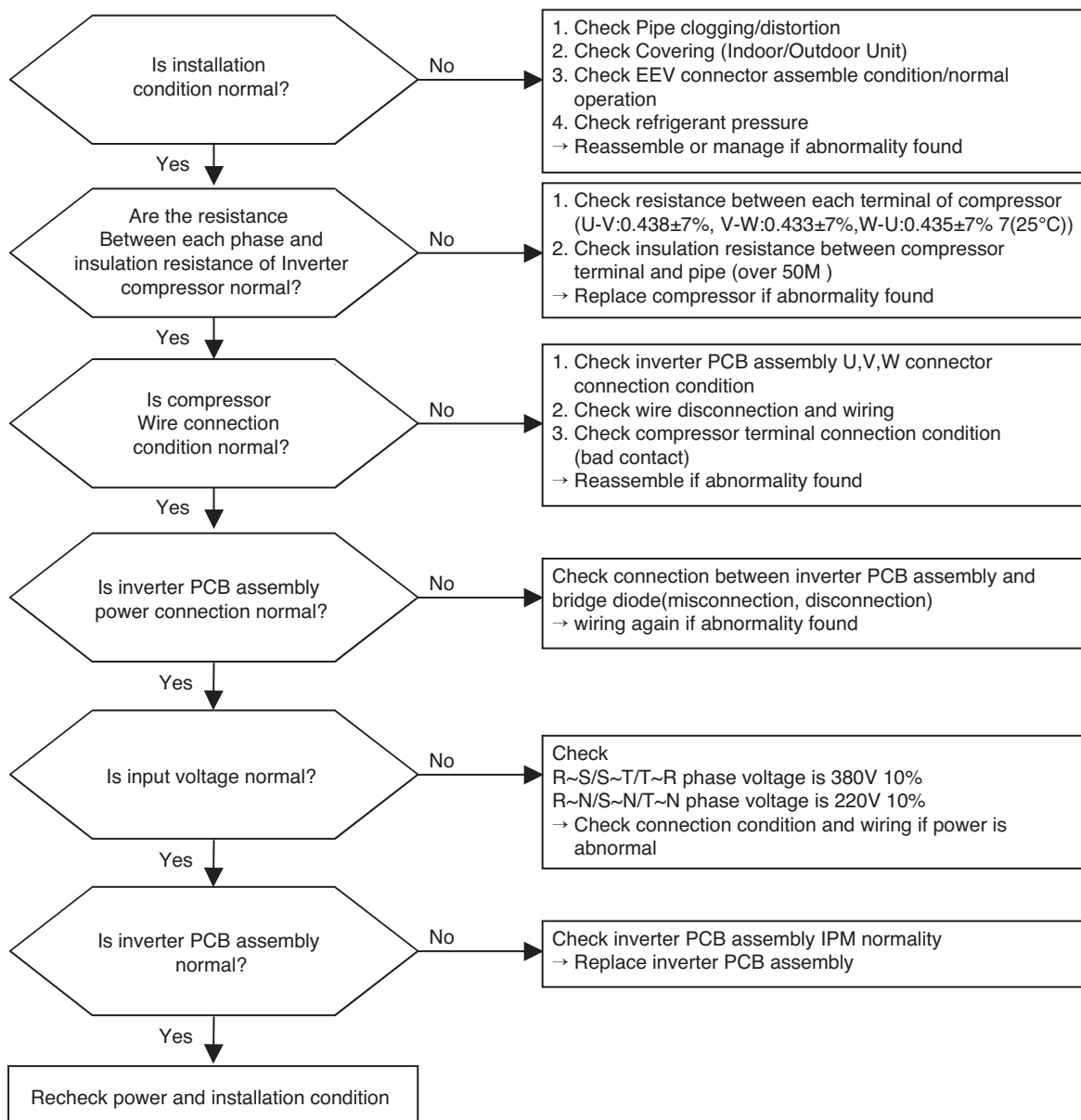

* Measuring resistance between each terminal of compressor



* Compressor wire connector connection

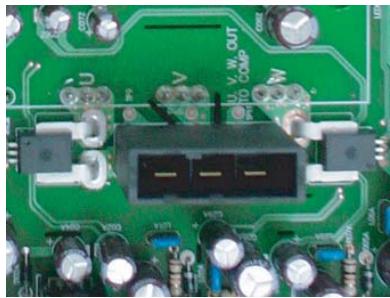

* Measuring input voltage

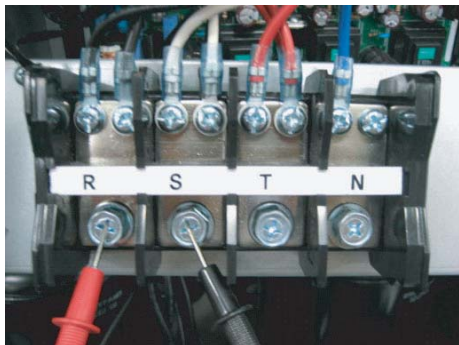

* Inverter PCB & bridge diode wiring

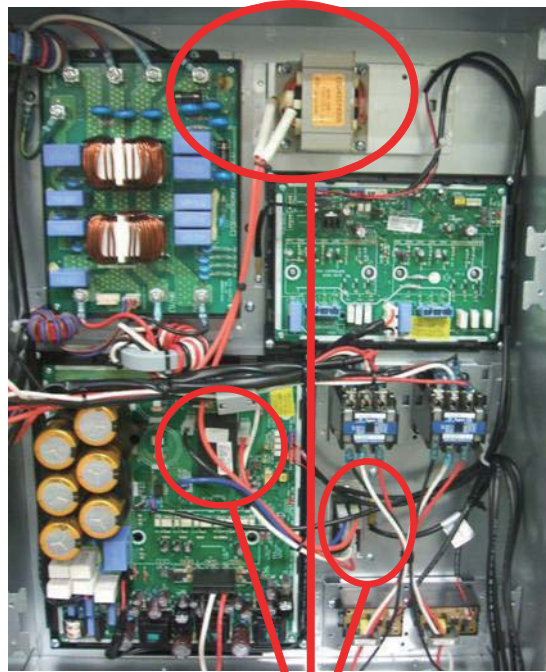

Check joining condition

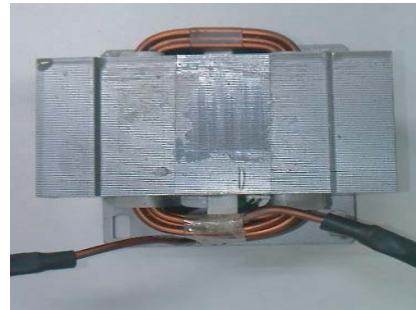

Error No.	Error Type	Error Point	Main Reasons
23*	Inverter Compressor DC Link Low Voltage	DC Voltage isn't charged after starting relay on	1. DC Link terminal misconnection/terminal contact fault 2. Starting relay damage 3. Condenser damage 4. Inverter PCB assembly damage (DC Link voltage sensing part) 5. Input voltage low
Master 231			
Slave1 232			
Slave2 233			
Slave3 234			

■ Error Diagnosis and Countermeasure Flow Chart

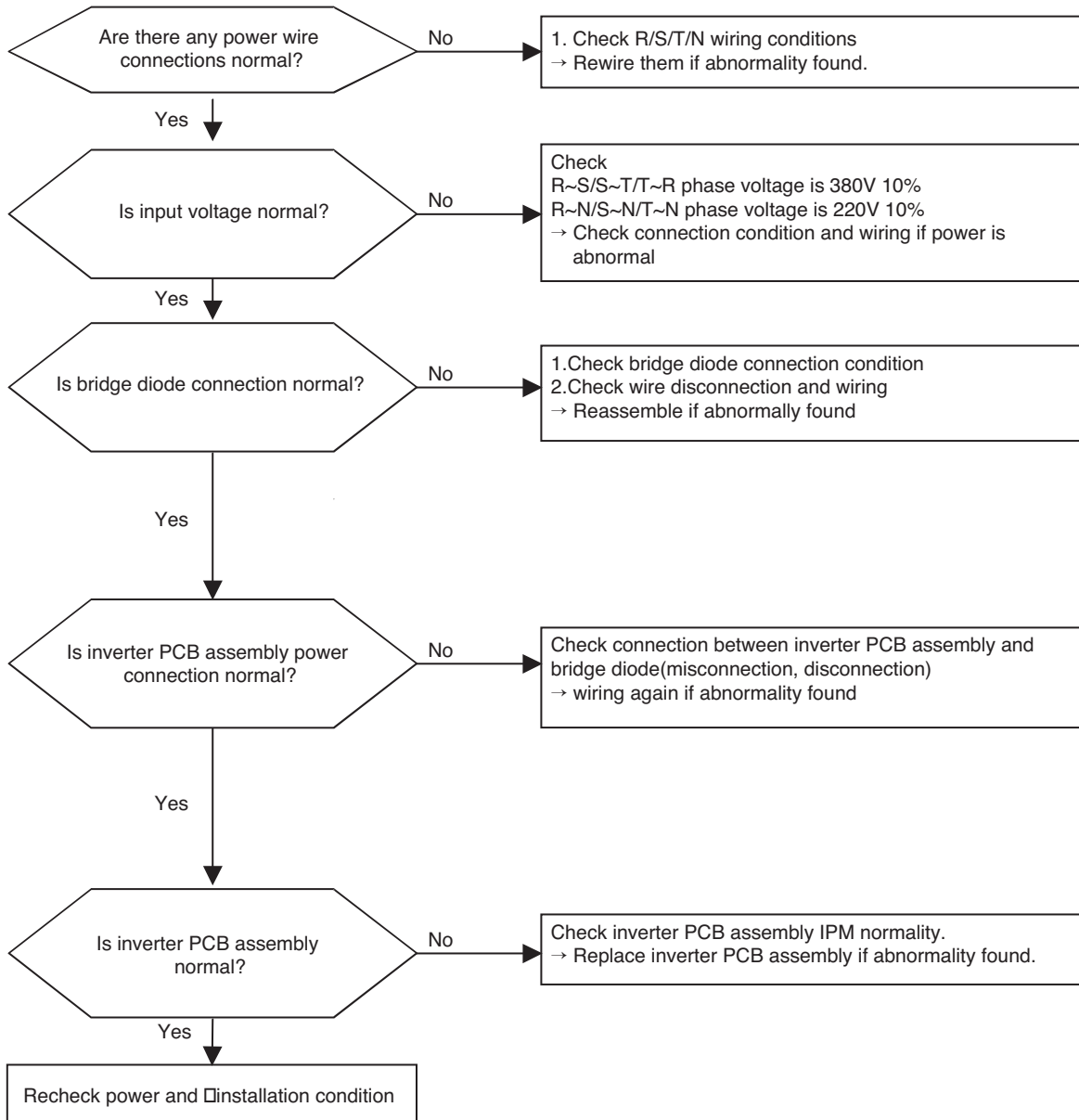

* Inverter PCB & bridge diode wiring

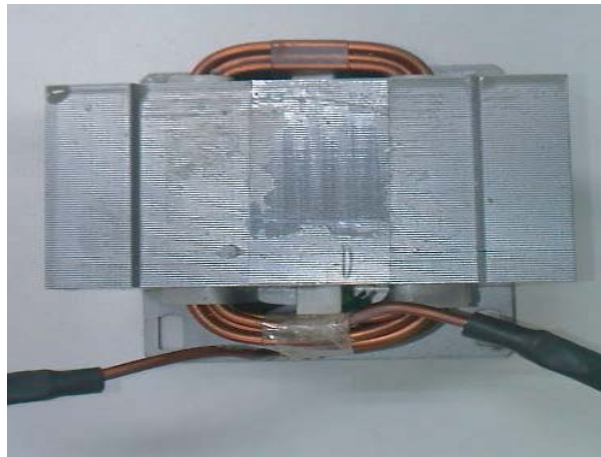

* Measuring input voltage

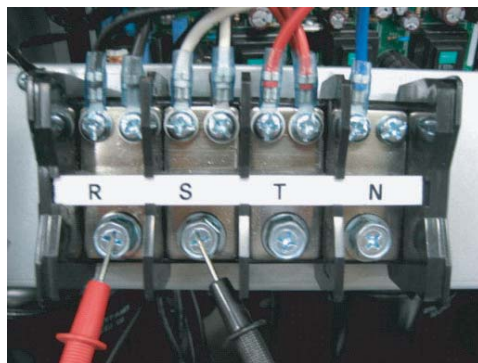

Error No.	Error Type	Error Point	Main Reasons
24 (Main) 109 (Sub1) 140 (Sub2) 154 (Sub3)	Excessive rise of discharge pressure in outdoor compressor	Compressor off due to the high pressure switch in outdoor unit	1. Defective high pressure switch 2. Defective fan of indoor unit or outdoor unit 3. Check valve of compressor clogged 4. Pipe distortion due to the pipe damage 5. Refrigerant overcharge 6. Defective LEV at the indoor or outdoor unit . 7. Covering or clogging(Outdoor covering during the cooling mode /Indoor unit filter clogging during the heating mode) 8. SVC valve clogging 9. Defective outdoor PCB

■ Error diagnosis and countermeasure flow chart

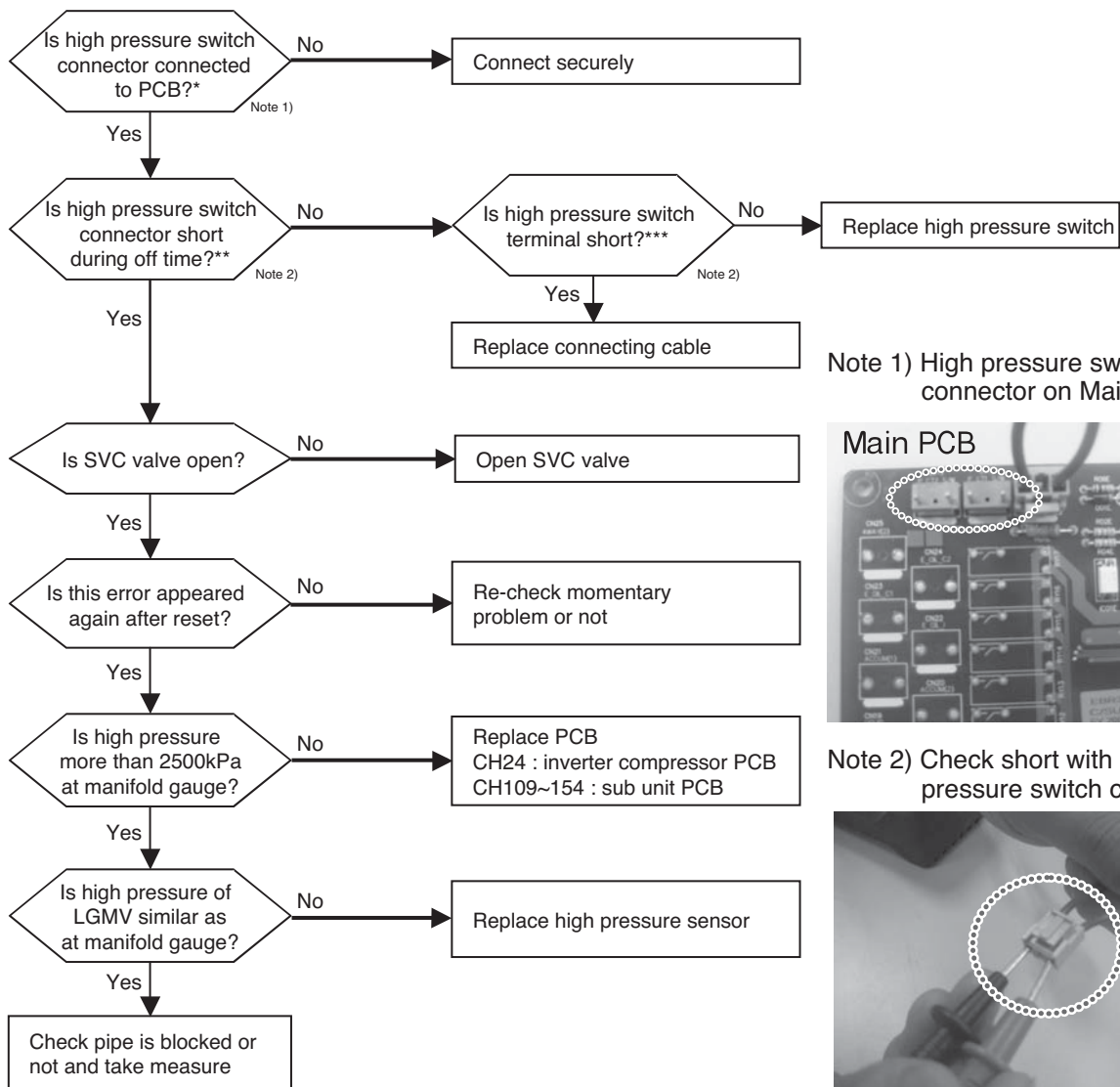

Note 1) High pressure switch connector on Main PCB

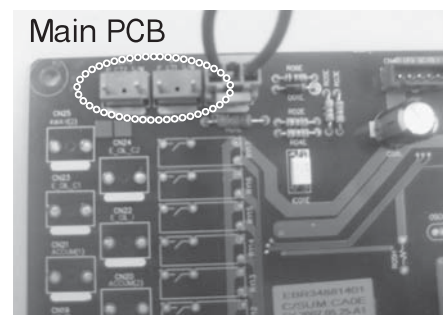

Note 2) Check short with high pressure switch connector

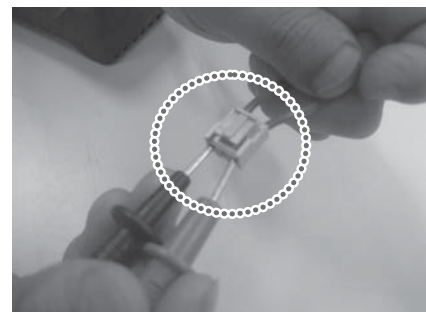

Error No.	Error Type	Error Point	Main Reasons
25* Master 251 Slave1 252 Slave2 253 Slave3 254	Input Voltage high/low	Input voltage is over limited value of the product (173V or less, 289V or more)	1. Input voltage abnormal (T-N) 2. Outdoor unit inverter PCB assembly damage (input voltage sensing part)

■ Error Diagnosis and Countermeasure Flow Chart

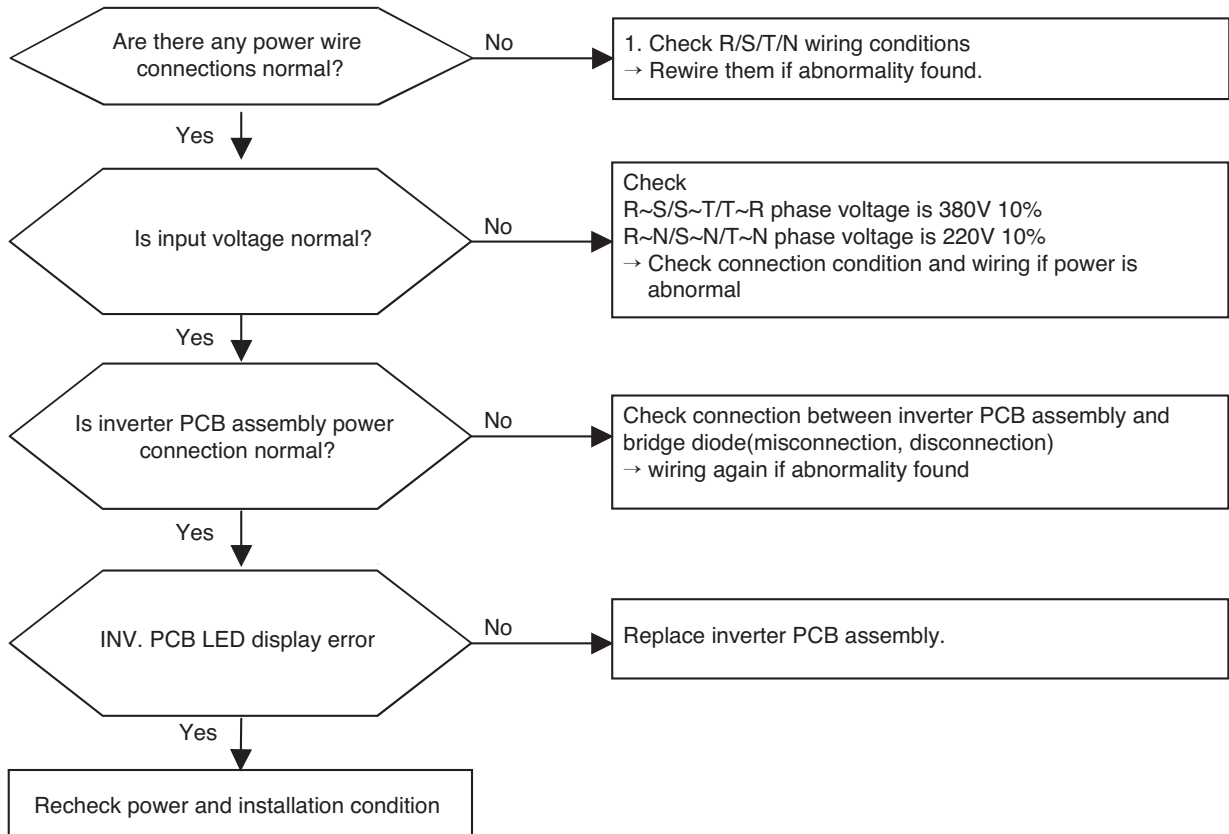

Error No.	Error Type	Error Point	Main Reasons
26* Master 261 Slave1 262 Slave2 263 Slave3 264	Inverter compressor starting failure Error	Starting failure because of compressor abnormality	<ol style="list-style-type: none"> 1. Overload operation (Pipe clogging/Covering/EEV defect/Ref. overcharge) 2. Compressor damage (Insulation damage/Motor damage) 3. Compressor wiring fault 4. ODU inverter PCB damage (CT)

■ Error Diagnosis and Countermeasure Flow Chart

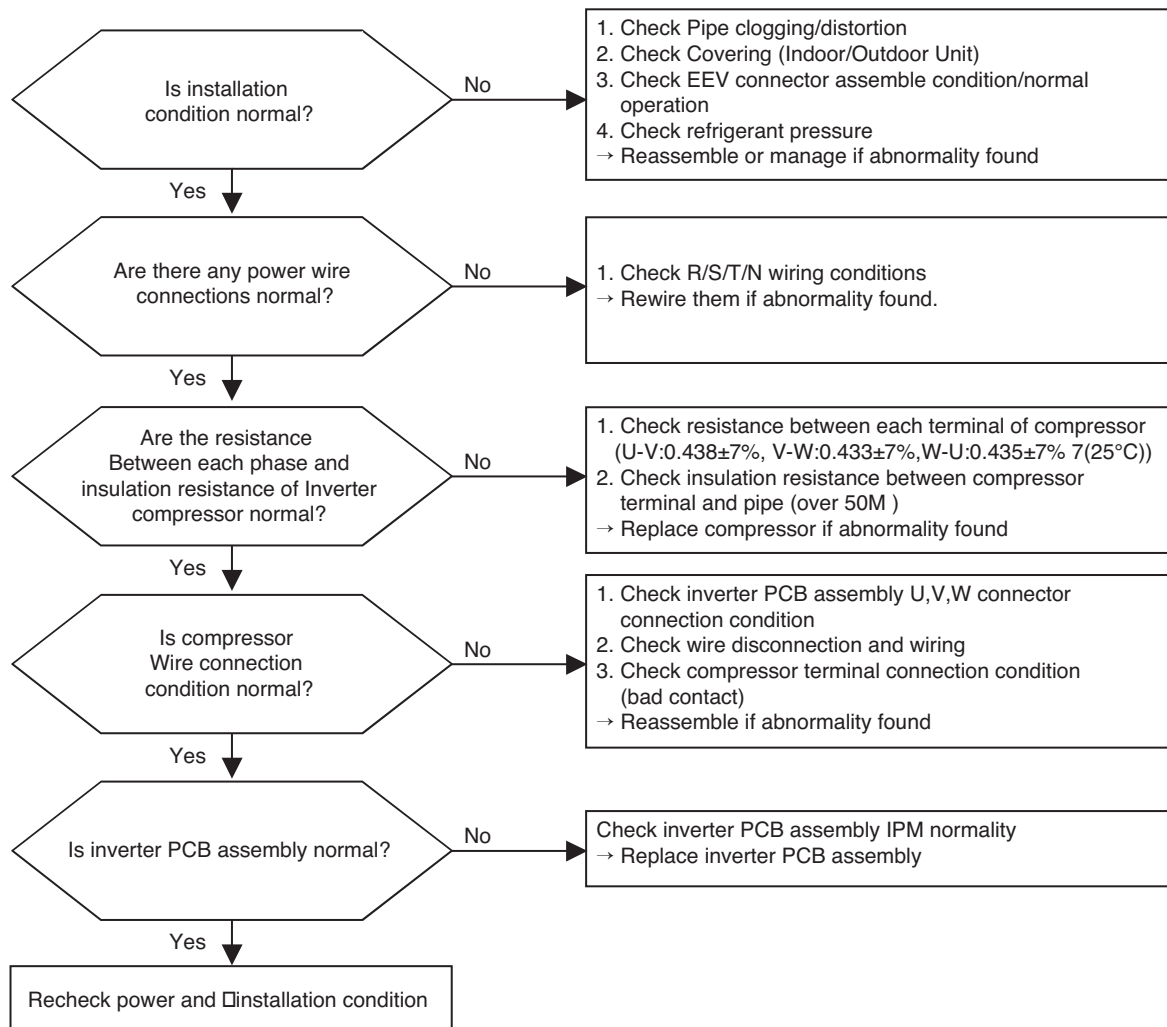

* Measuring resistance
between each terminal of
compressor



* Compressor wire connection

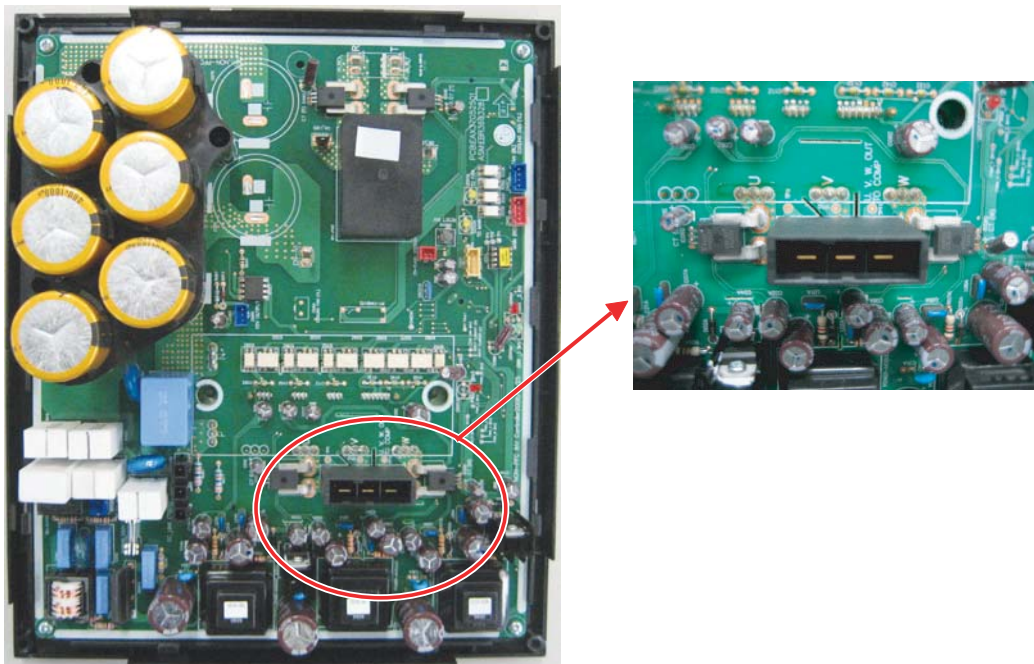

Error No.	Error Type	Error Point	Main Reasons
28* Master 281 Slave1 282 Slave2 283 Slave3 284	Inverter DC link high voltage error	Inv PCB DC link voltage supplied over 780V	1. Input voltage abnormal (R,S,T,N) 2. ODU inverter PCB damage (DC Link voltage sensing part)

■ Error Diagnosis and Countermeasure Flow Chart

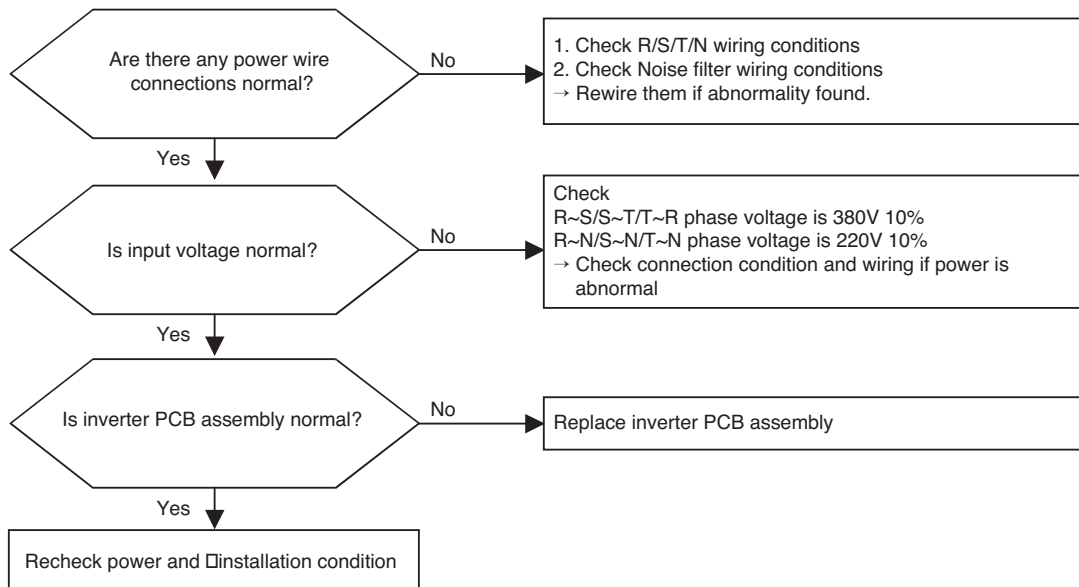

* Measuring input voltage



* Noise filter wiring

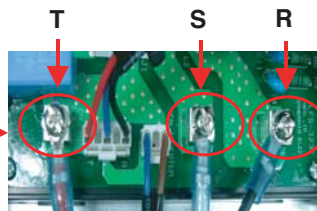
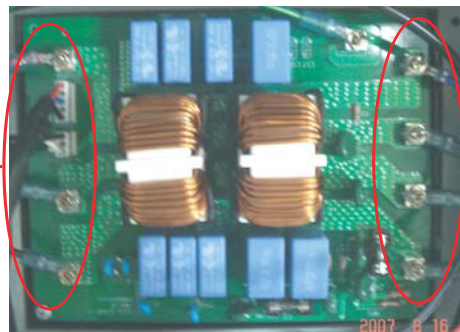

Noise filter output(lower part)

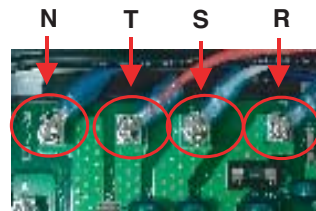

Noise filter input (upper part)

Error No.	Error Type	Error Point	Main Reasons
29* Master 291 Slave1 292 Slave2 293 Slave3 294	Inverter compressor over current	Inverter compressor input current is over 30A	<ol style="list-style-type: none"> 1. Overload operation (Pipe clogging/Covering/EEV defect/Ref. overcharge) 2. Compressor damage(Insulation damage/Motor damage) 3. Input voltage low 4. ODU inverter PCB assembly damage

■ Error Diagnosis and Countermeasure Flow Chart

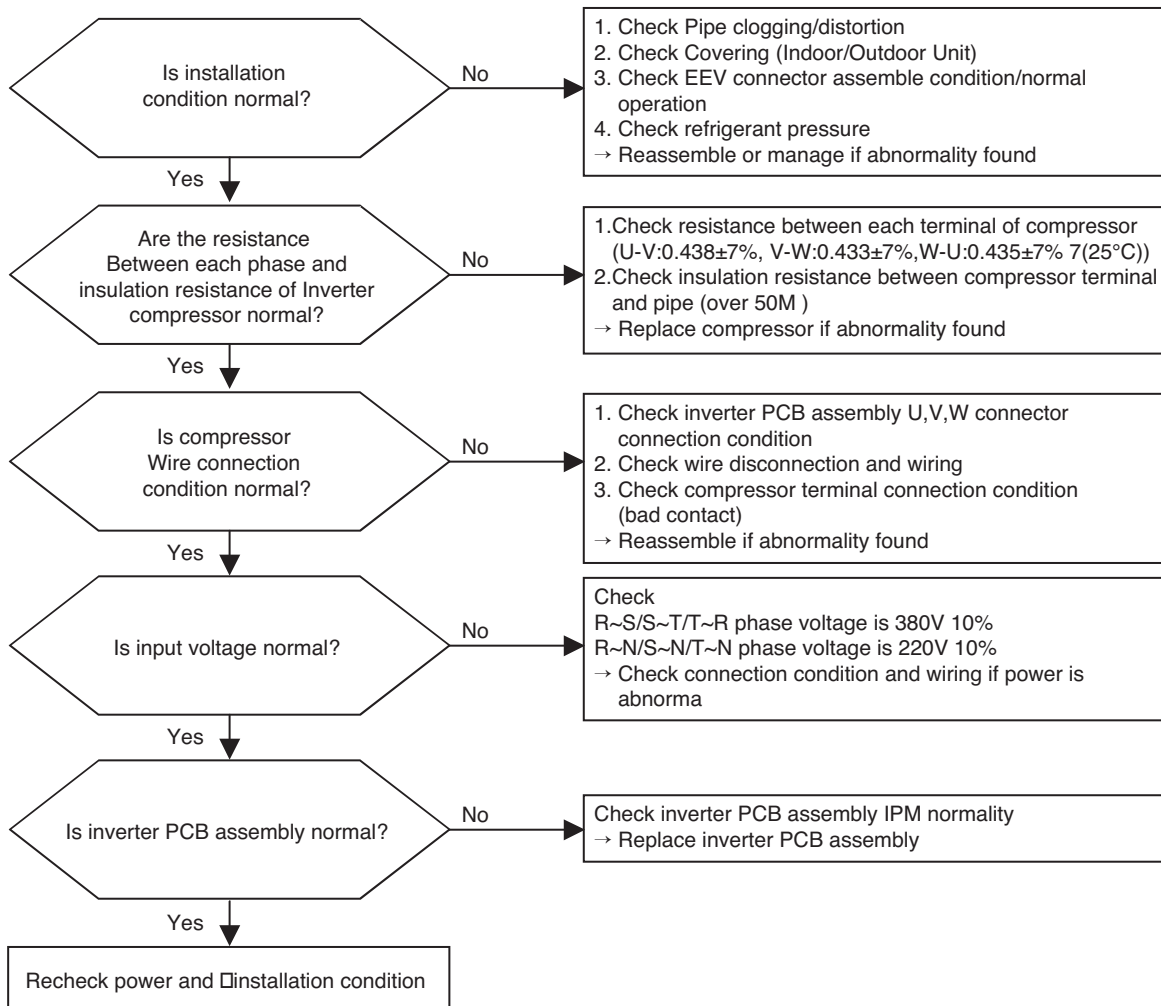

* Measuring resistance between each terminal of compressor



* Measuring input voltage

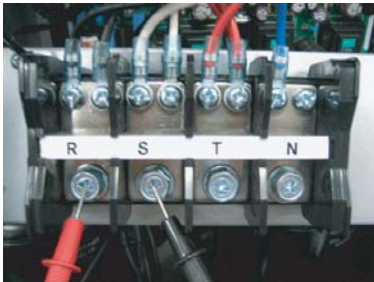

* Compressor wire connection

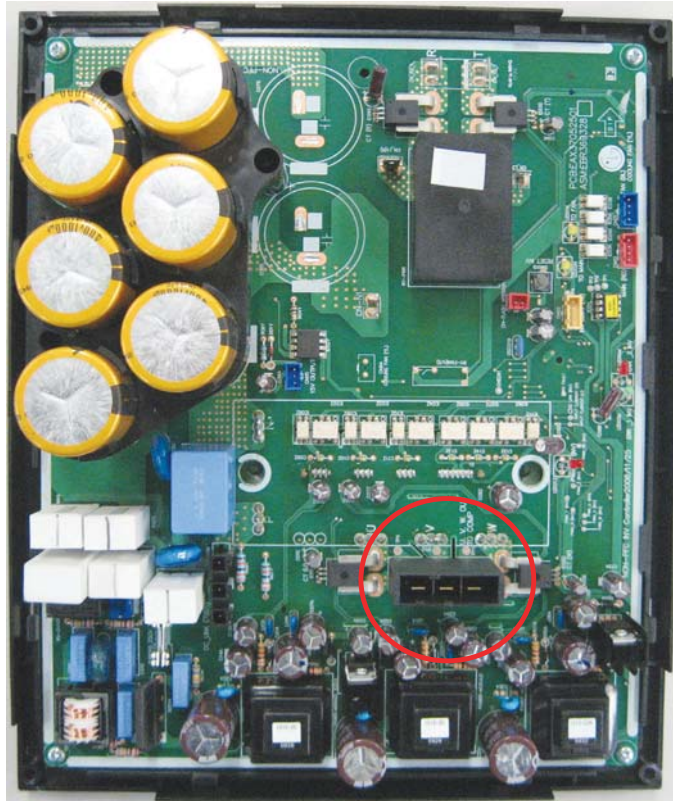

Error No.	Error Type	Error Point	Main Reasons
30* Master 301 Slave1 302 Slave2 303 Slave3 304	Master Outdoor Unit Constant Speed Compressor 2 Discharge Temperature Sensor	System is turned off by Master Outdoor Unit Constant Speed Compressor 2 Discharge Temperature Sensor	1. Constant Speed Compressor 2 Discharge Temperature Sensor Fault 2. Refrigerant Short/Leakage 3. EEV Fault
32* Master 321 Slave1 322 Slave2 323 Slave3 324	Over-increase discharge temperature of inverter compressor at main outdoor unit	Compressor is off because of over-increase discharge temperature of inverter compressor	1. Temperature sensor defect of inverter compressor discharge pipe 2. Refrigerant shortage / leak 3. EEV defect 4. Liquid injection valve defect
33* Master 331 Slave1 332 Slave2 333 Slave3 334	Over-increase discharge temperature of constant compressor 1 at main constant outdoor and sub constant outdoor unit	Compressor is off because of over-increase discharge temperature of constant compressor 1 at main and sub outdoor unit	1. Temperature sensor defect of constant compressor 1 discharge pipe? 2. Refrigerant shortage/leak 3. EEV defect 4. Liquid injection valve defect

■ Error diagnosis and countermeasure flow chart

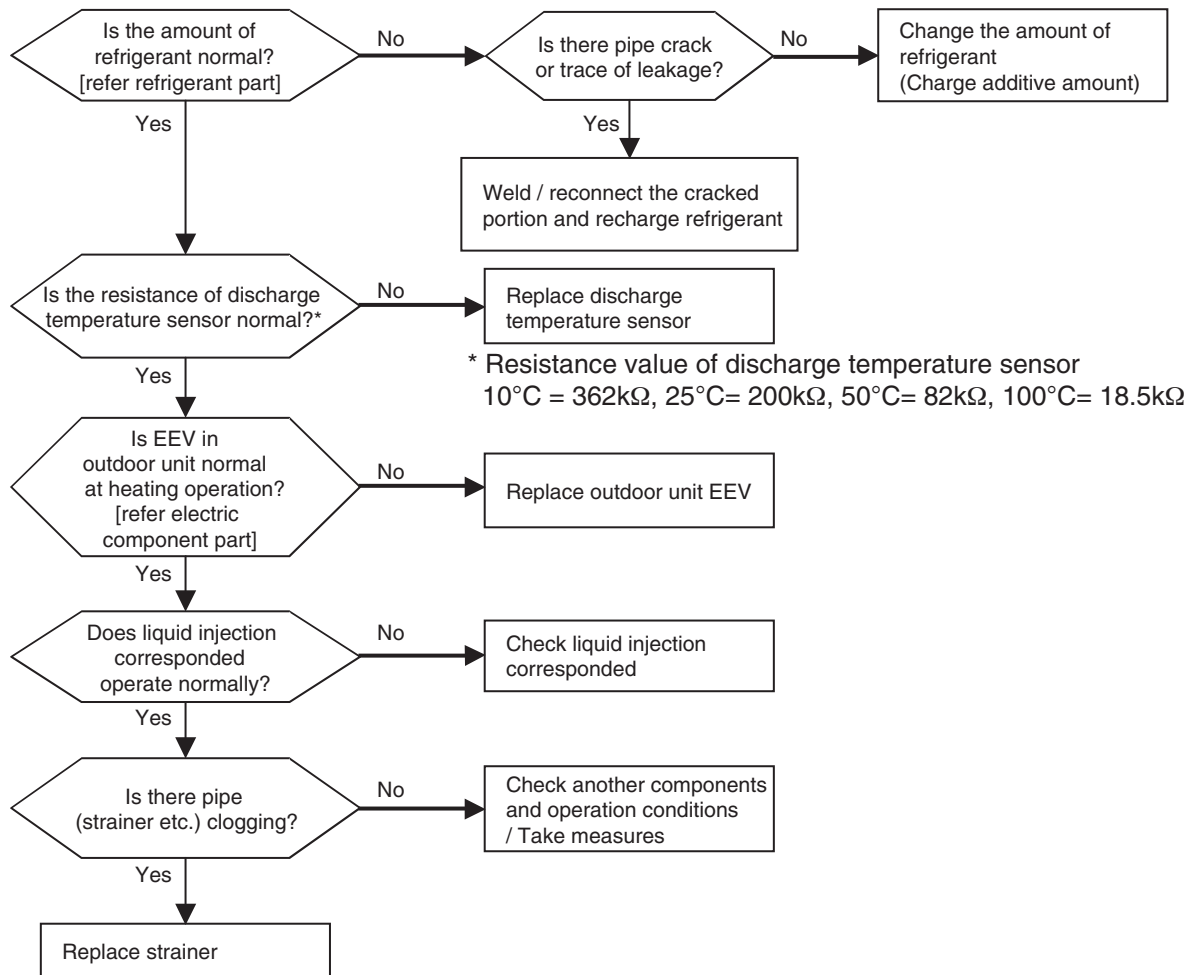

Error No.	Error Type	Error Point	Main Reasons
34*	Over-increase of discharge pressure of compressor	Error happens because of 3 times successive compressor off due to over-increase of high pressure by high pressure sensor	1. Defect of high pressure sensor
Master 341			2. Defect of indoor or outdoor unit fan
Slave1 342			3. Deformation because of damage of refrigerant pipe
Slave2 343			4. Over-charged refrigerant
Slave3 344			5. Defective indoor / outdoor unit EEV
			6. When blocked - Outdoor unit is blocked during cooling - Indoor unit filter is blocked during heating
			7. SVC valve is clogged
			8. PCB defect of outdoor unit
			10. Indoor unit pipe temperature sensor defect

■ Error diagnosis and countermeasure flow chart

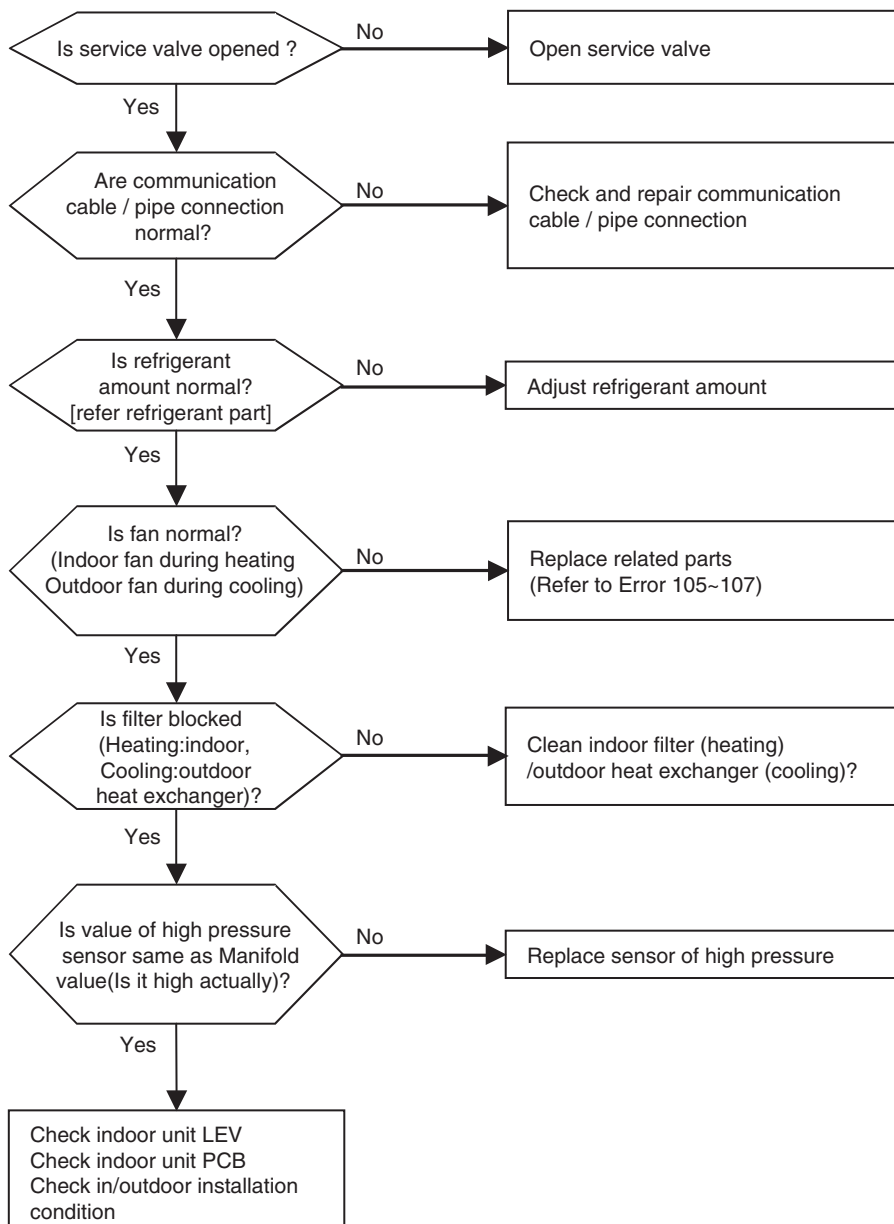

Error No.	Error Type	Error Point	Main Reasons
35* Master 351 Slave1 352 Slave2 353 Slave3 354	Excessive drop of discharge pressure of compressor	Error happens because of 3 times successive compressor off due to excessive drop of low pressure by the low pressure sensor	<ol style="list-style-type: none"> 1. Defective low pressure sensor 2. Defective outdoor/indoor unit fan 3. Refrigerant shortage/leakage 4. Deformation because of damage of refrigerant pipe 5. Defective indoor / outdoor unit EEV 6. Covering / clogging (outdoor unit covering during the cooling mode/ indoor unit filter clogging during heating mode) 7. SVC valve clogging 8. Defective outdoor unit PCB 9. Defective indoor unit pipe sensor

■ Error diagnosis and countermeasure flow chart

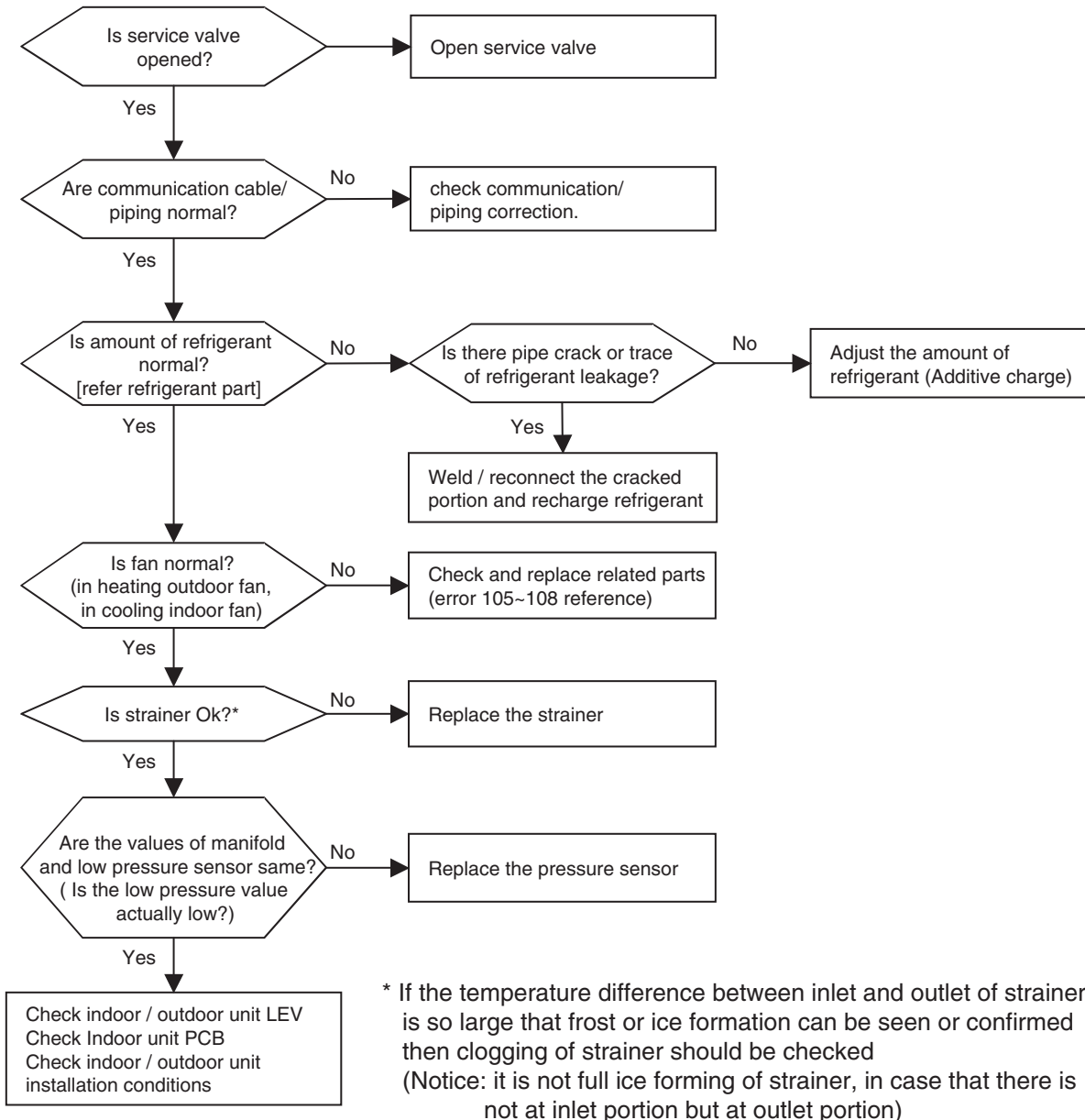

Error No.	Error Type	Error Point	Main Reasons
41* (Inverter) Master 411 Slave1 412 Slave2 413 Slave3 414 47* (Constant 1) Master 471	Slave1 472 Slave2 473 Slave3 474 48* (Constant 2) Master 481 Slave1 482 Slave2 483 Slave3 484	Compressor discharge pipe temperature sensor error	1. Defective connection of the compressor discharge pipe temperature sensor 2. Defective discharge pipe compressor sensor of the compressor (open/short) 3. Defective outdoor PCB

■ Error diagnosis and countermeasure flow chart

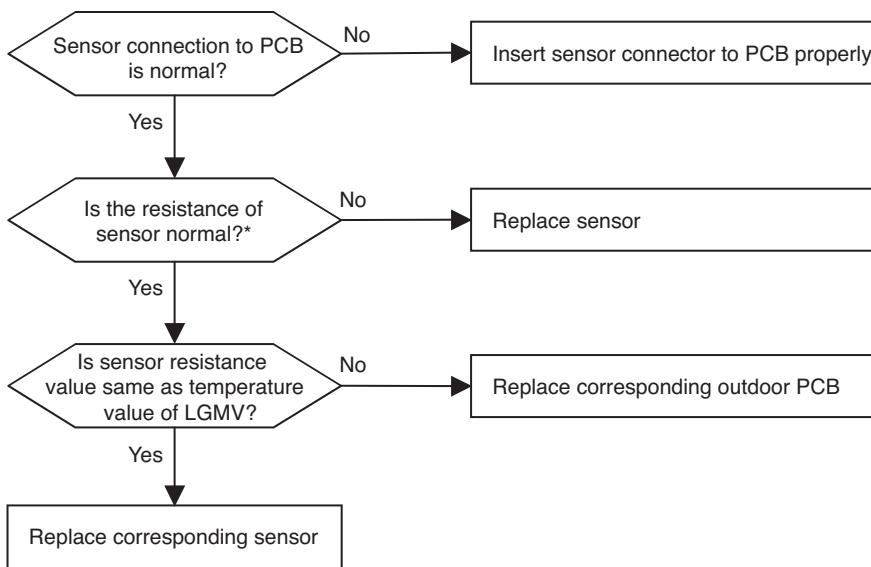

* Error is generated if the resistance is more than 5M(open) and less than 2k (short)

Note: Standard values of resistance of sensors at different temperatures (5% variation)
 10C = 362k : 25C= 200k : 50C= 82k : 100C= 18.5k

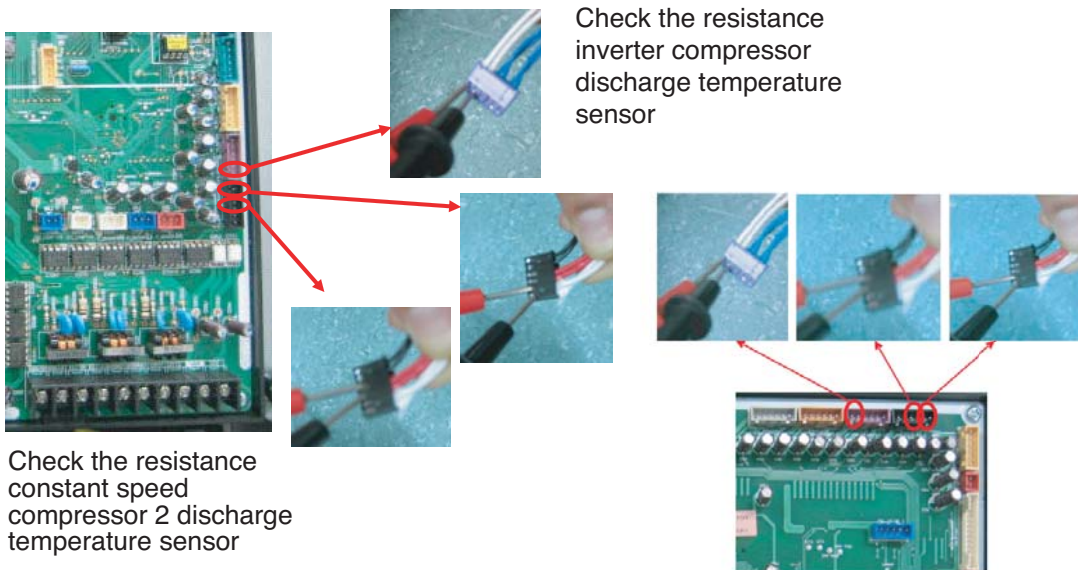

Error No.	Error Type	Error Point	Main Reasons
42* Master 421 Slave1 422 Slave2 423 Slave3 424	Sensor error of low pressure	Abnormal value of sensor (Open/Short)	1. Bad connection of low pressure connector 2. Defect of low pressure connector (Open/Short) 3. Defect of outdoor PCB
43* Master 431 Slave1 432 Slave2 433 Slave3 434	Sensor error of high pressure	Abnormal value of sensor (Open/Short)	1. Bad connection of high pressure connector 2. Defect of high pressure connector (Open/Short) 3. Defect of outdoor PCB

■ Error diagnosis and countermeasure flow chart

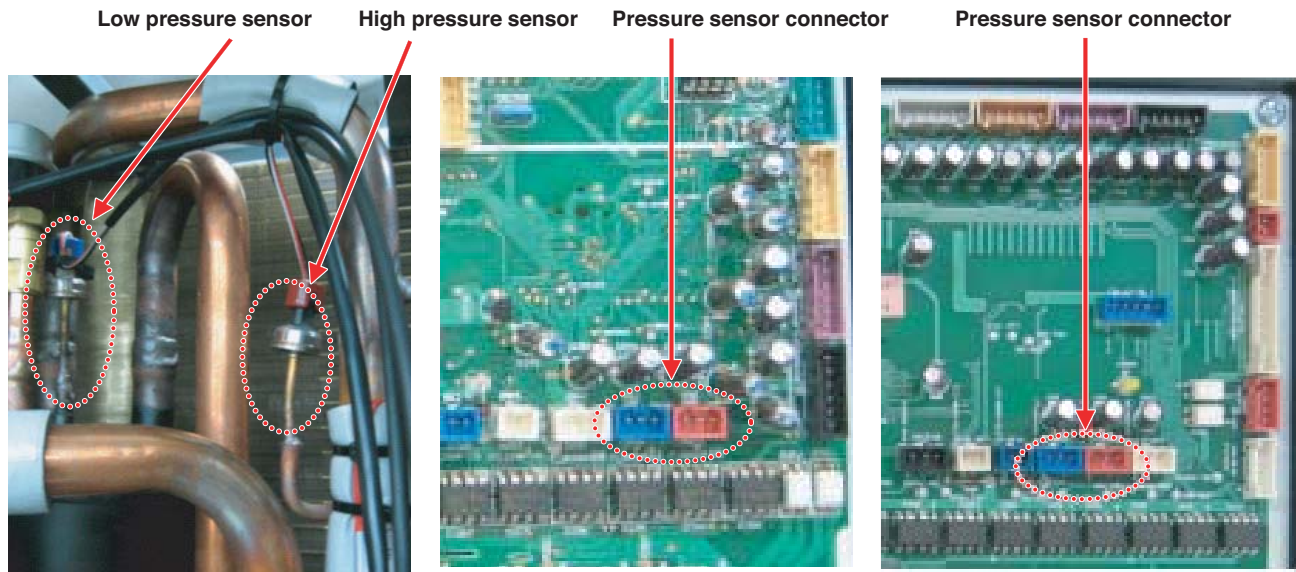
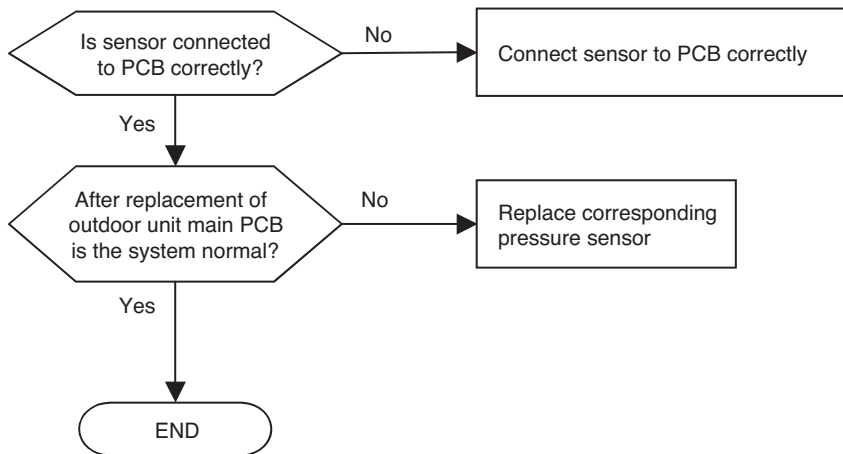

Error No.	Error Type	Error Point	Main Reasons
44* Master 441 Slave1 442 Slave2 443 Slave3 444	Sensor error of outdoor air temperature	Abnormal value of sensor (Open/Short)	1. Bad connection of air temperature connector 2. Defect of air temperature connector(Open/Short) 3. Defect of outdoor PCB
45* Master 451 Slave1 452 Slave2 453 Slave3 454	Piping temperature sensor error of heat exchanger in master & slave outdoor unit heat exchanger (A,B)	Abnormal value of sensor (Open/Short)	1. Bad connection of air temperature connector 2. Defect of air temperature connector(Open/Short) 3. Defect of outdoor PCB
46* Master 461 Slave1 462 Slave2 463 Slave3 464	Compressor suction temperature sensor error	Abnormal value of sensor (Open/Short)	1. Bad connection of air temperature connector 2. Defect of air temperature connector(Open/Short) 3. Defect of outdoor PCB
49* Master 491 Slave1 492 Slave2 493 Slave3 494	Outdoor Unit IPM Temperature Sensor Fault	Outdoor Unit IPM Temperature Sensor Open or Short	1. Bad connection of air temperature connector 2. Defect of air temperature connector(Open/Short) 3. Defect of outdoor PCB

■ Error diagnosis and countermeasure flow chart

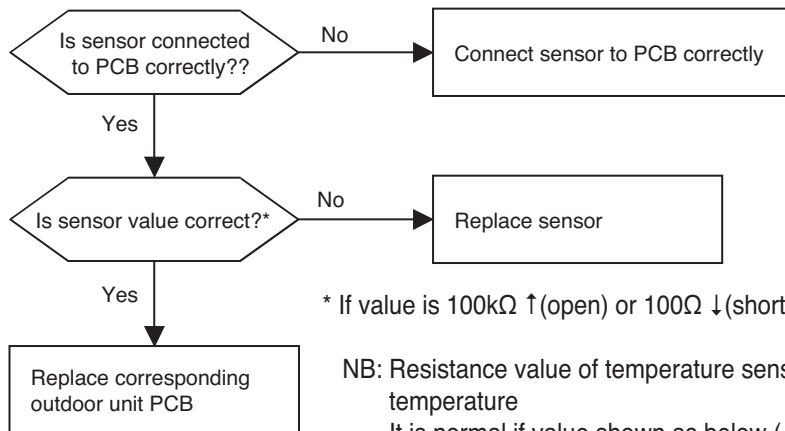

* If value is 100kΩ ↑(open) or 100Ω ↓(short), error occurs

NB: Resistance value of temperature sensor change according to temperature

It is normal if value shown as below (±5% error)

Sensor of air temperature: 10°C = 20.7kΩ : 25°C= 10kΩ : 50°C= 3.4kΩ

Sensor of piping temperature: 10°C = 10kΩ : 25°C= 5Ωk : 50°C= 1.8kΩ

Error No.	Error Type	Error Point	Main Reasons
153* Master 11-> 531 Slave1 12-> 532 Slave2 13-> 533 Slave3 14-> 534	Outdoor Unit Upper Heat Exchanger Temperature Sensor Fault	Outdoor Unit Upper Heat Exchanger Temperature Sensor open or short	1. Temperature Sensor Connecting Fault 2. Temperature Sensor(Open/Short) 3. Main PCB Fault
154* Master 11-> 541 Slave1 12-> 542 Slave2 13-> 543 Slave3 14-> 544	Outdoor Unit Low Heat Exchanger Temperature Sensor Fault	Outdoor Unit Low Heat Exchanger Temperature Sensor open or short	1. Temperature Sensor Connecting Fault 2. Temperature Sensor(Open/Short) 3. Main PCB Fault

Error No.	Error Type	Error Point	Main Reasons
50* Master 501 Slave1 502 Slave2 503 Slave3 504	ODU 3phase power omission error	Omitting one or more of R,S,T input power	<ol style="list-style-type: none"> 1. Input Voltage abnormal (R,S,T,N) 2. Check power Line connection condition 3. Main PCB damage 4. Inverter PCB input current sensor fault

■ Error Diagnosis and Countermeasure Flow Chart

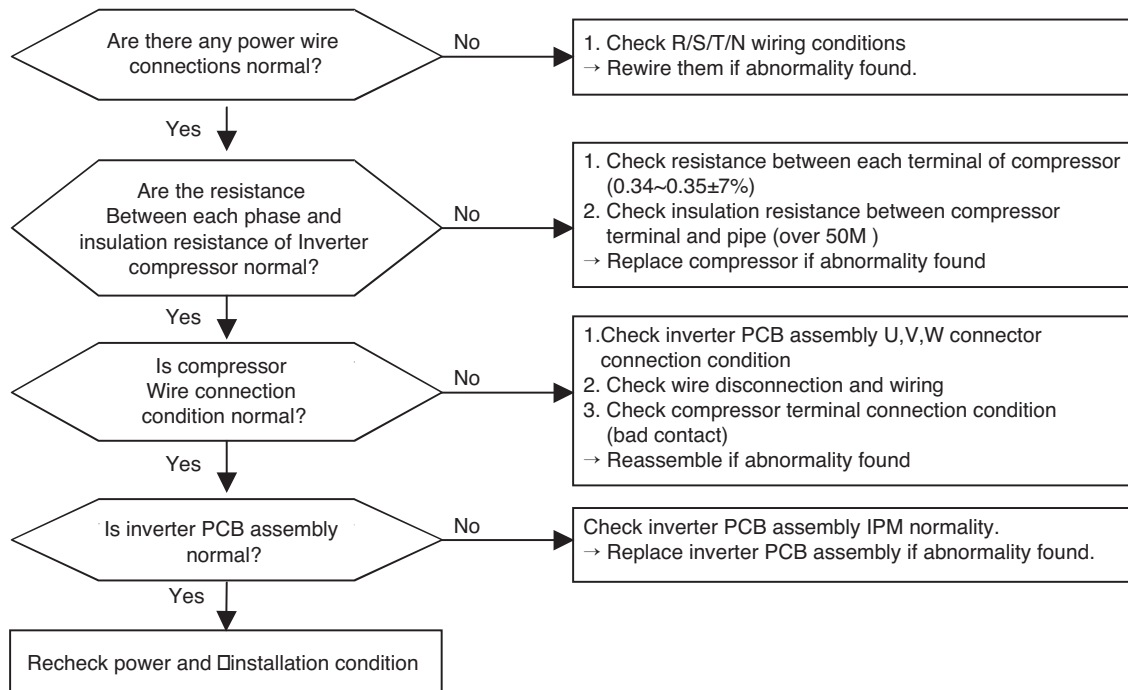

* Measuring input voltage



* Noise filter wiring

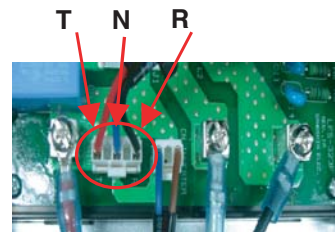
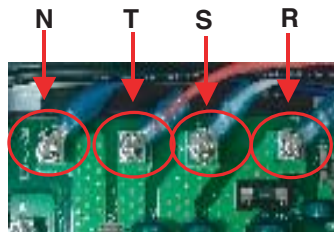

* Main PCB power connection

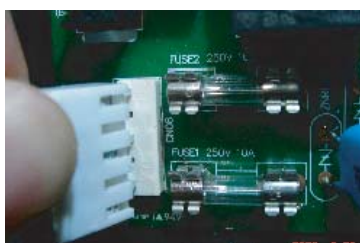

* Field Fault Case

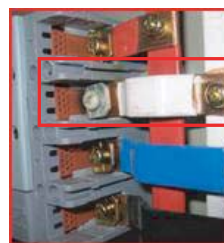

* R-Phase Terminal Changed Color.

Error No.	Error Type	Error Point	Main Reasons
51	Over-Capacity (Sum of indoor unit capacity is more than outdoor capacity)	Sum of indoor unit capacity exceed outdoor unit capacity specification	1. 130% more than outdoor unit rated capacity 2. Wrong connection of communication cable/piping 3. Control error of slave outdoor unit Dip switch 4. Power supply defect of slave unit PCB 5. Defect of outdoor unit PCB

■ Error diagnosis and countermeasure flow chart

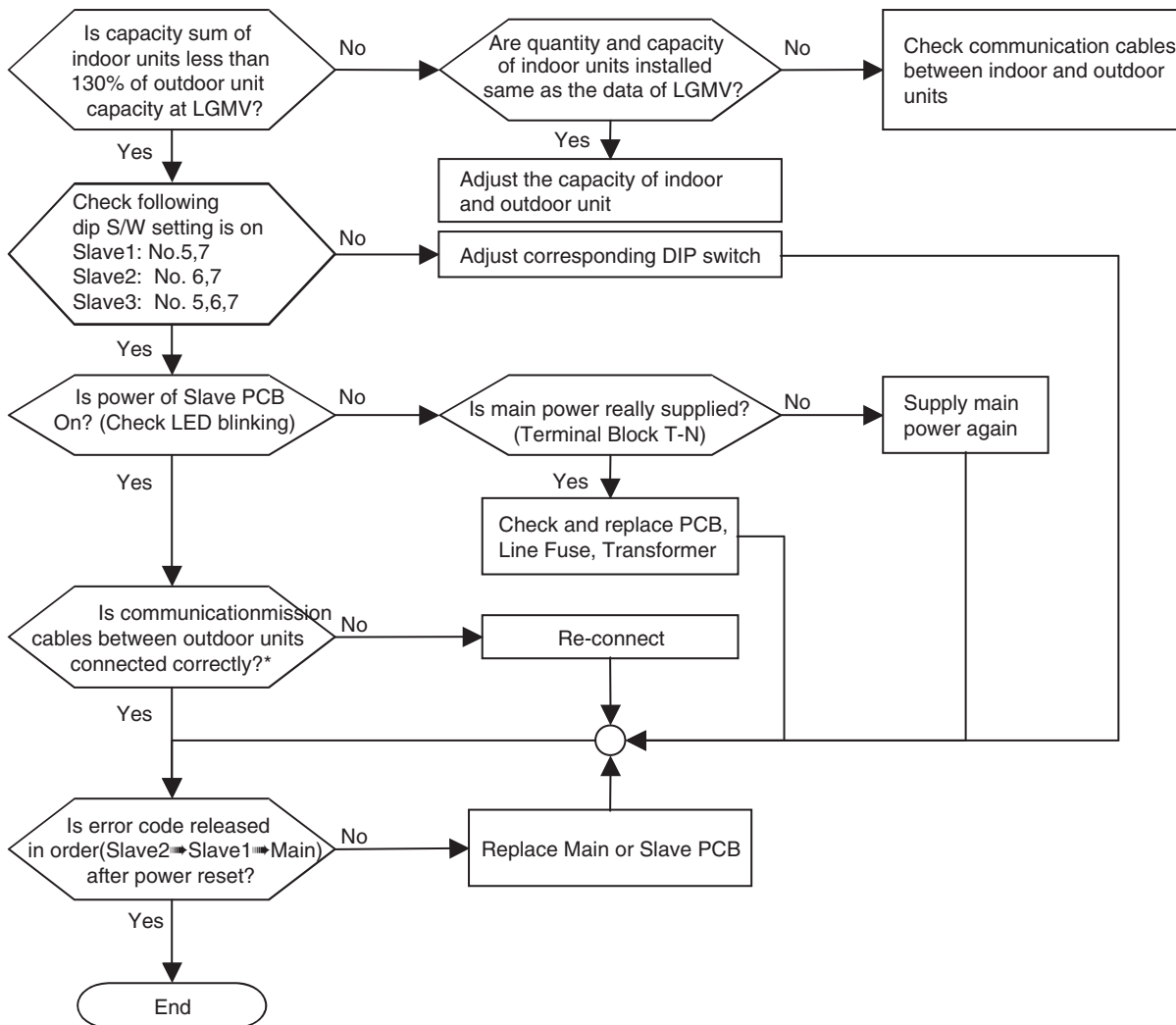

* In order to check communication cables between outdoor units, check in order as below
 : PCB connectors ⇒ terminal block ⇒ communication cables

Error No.	Error Type	Error Point	Main Reasons
52* Master 521 Slave1 522 Slave2 523	Communication error between (Inverter PCB → Main PCB)	Main controller of Master unit of Master unit can't receive signal from inverter controller	1. Power cable or communication cable is not connected 2. Defect of outdoor Main fuse/Noise Filter 3. Defect of outdoor Main / inverter PCB

■ Error diagnosis and countermeasure flow chart

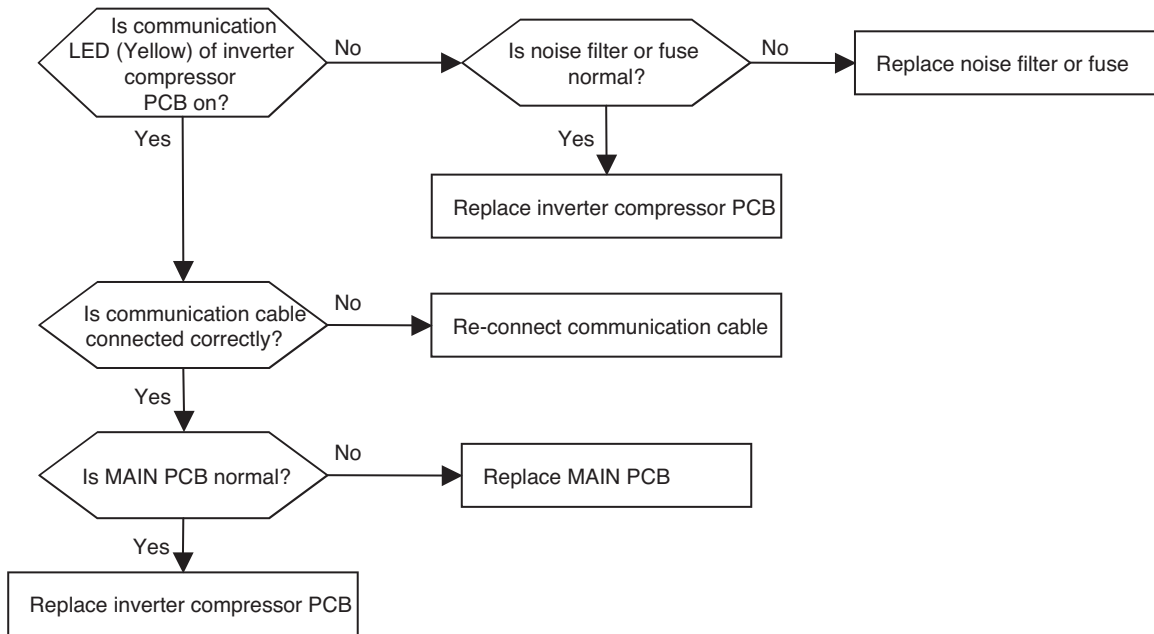

* The method of checking MAIN PCB and inverter compressor PCB (If normal, communication LED blinks)

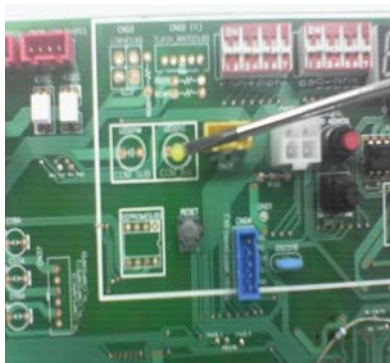

communication connector & LED in MAIN PCB



communication connector & LED in inverter compressor PCB

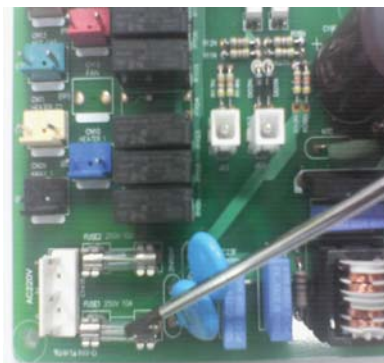

Main PCB Fuse

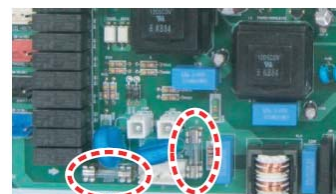
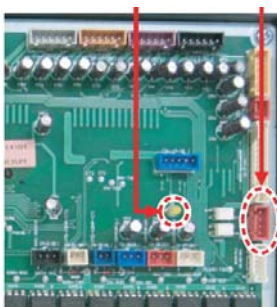

Error No.	Error Type	Error Point	Main Reasons
53	Communication error (Indoor unit → Main PCB)	In case Main PCB can't receive signal from indoor unit	1. Communication cables are not connected 2. Communication cables are short / open 3. Defect of outdoor Main / indoor PCB 4. ODU/IDU Main PCB Damage. 5. communication Wire Connection Fault.

■ Error diagnosis and countermeasure flow chart

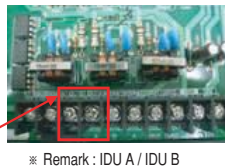
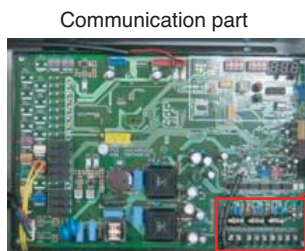
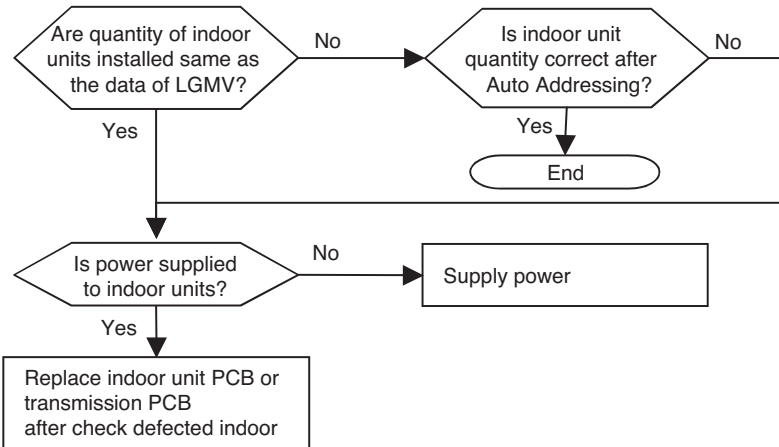

In case of CH53, almost happened with CH05, the indoor units not operated actually are normal so check with same method of CH05. and additionally check as shown as below and above flow chart

- Although the quantity of indoor units installed is same as LGMV data there may be a few indoor units with which the number of communication is not increased with LGMV
- Although the quantity of indoor units installed is not same as LGMV data, and if communication of the indoor unit displayed at LGMV is done well then the indoor unit suspected to have some problem (and is not appear at LGMV) may have following problems
 - ① wrong connection of communication cable or power cable
 - ② fault of power / PCB / communication cable
 - ③ duplication of indoor unit number
- If communication is not doing well wholly then the Auto Addressing is not done
- The case that CH53 appear at indoor unit also Auto Addressing is not done so indoor unit address may be duplicated

* After replacement of indoor unit PCB, Auto Addressing should be done, if central controller is installed then the central control address also should be input.
 In case that only communication PCB is replaced above process is not needed

Error No.	Error Type	Error Point	Main Reasons
54* Master 541 Slave1 542 Slave2 543 Slave3 544	Wrong connection of 3Ø power supply cable (Reverse direction / missing a phase)	Wrong connection of 3Ø power supply cable (Reverse direction / missing a phase)	1. Main PCB defect 2. No power of R,S,T supplied 3. Wrong connection of R,S,T cables 4. Main Pcb Fuse failure

■ Error diagnosis and countermeasure flow chart

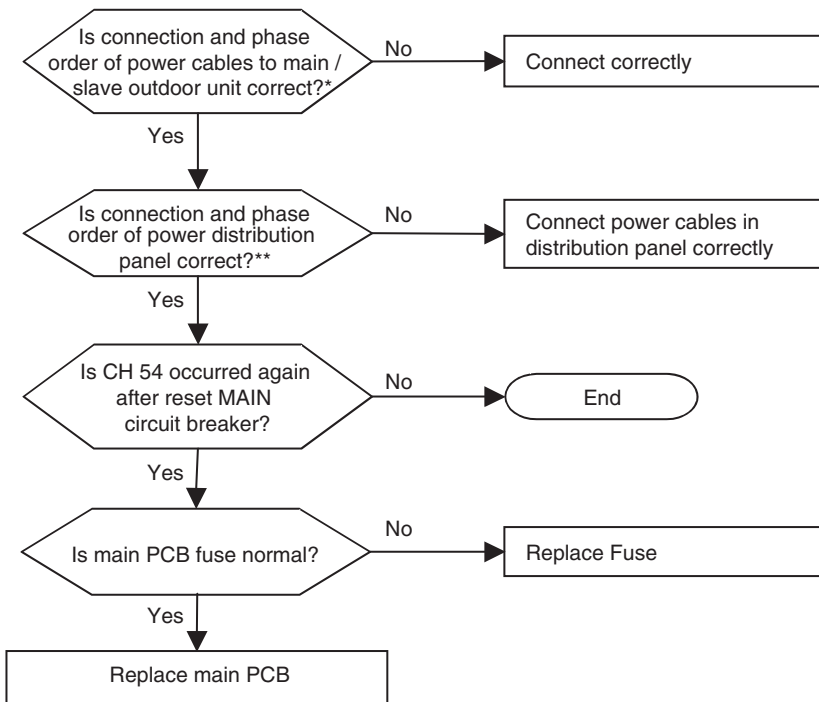

* Check power cable connection state, phase (R-S-T) order, power supply state in control box of product



** Check power cable connection state, phase order, power supply state in distribution panel



Error No.	Error Type	Error Point	Main Reasons
57* Master 571 Slave1 572 Slave2 573 Slave3 574	Communication error : Main PCB --> Inverter PCB	Failing to receive inverter signal at main PCB of Outdoor Unit	<ol style="list-style-type: none"> 1. Bad Connection Between Inv and Main 2. Communication Wire Noise Effect 3. ODU Main PCB Damage 4. ODU Inv PCB Damage

■ Error diagnosis and countermeasure flow chart

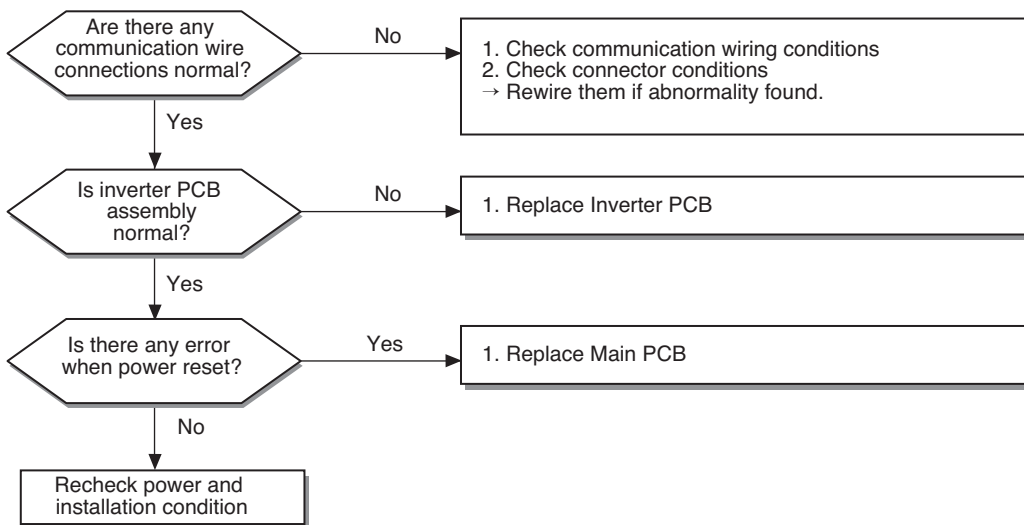

Inverter/Fan PCB

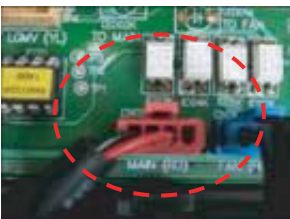

Main PCB

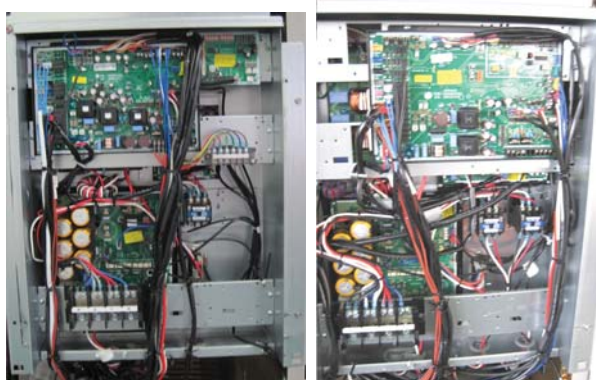

Error No.	Error Type	Error Point	Main Reasons
59* Master 591 Slave1 592 Slave2 593 Slave3 594	Series Installation Error	Series Installation of Slave Outdoor Unit Larger Than Master Capacity	1. Dip Switch Setting Error

■ Error Diagnosis and Countermeasure Flow Chart

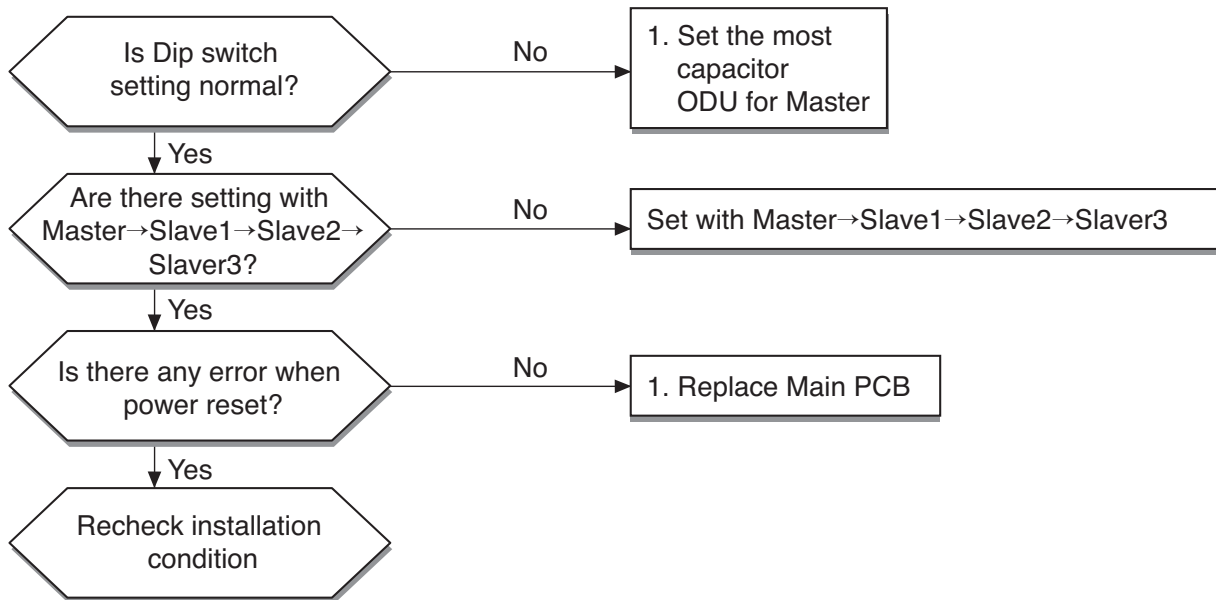

* Dip Switch Setting

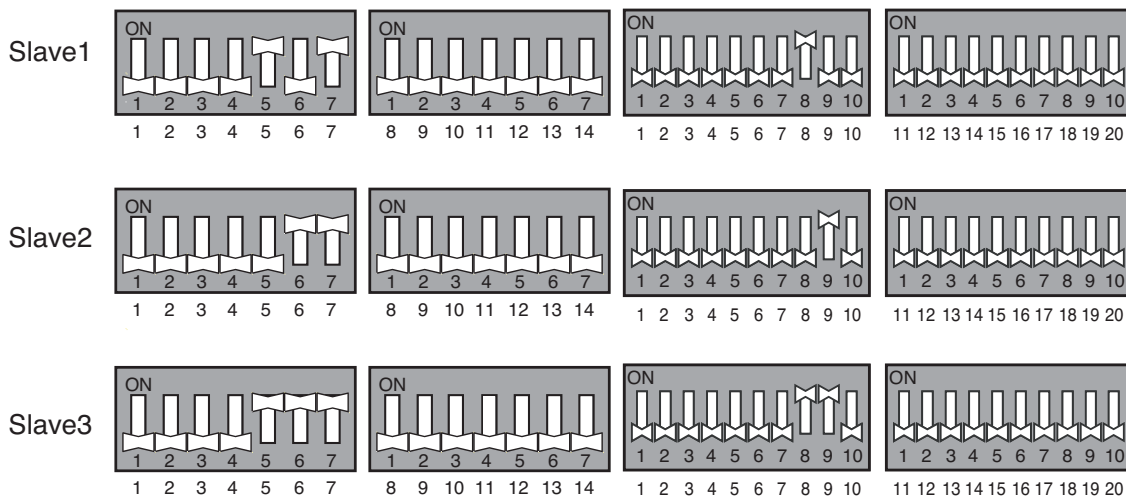

Error No.	Error Type	Error Point	Main Reasons
60* Master 601 Slave1 602 Slave2 603 Slave3 604	Inverter PCB EEPROM error	EEPROM Access error and Check SUM error	1. EEPROM contact defect/wrong insertion 2. Different EEPROM Version 3. ODU inverter PCB assembly damage

■ Error Diagnosis and Countermeasure Flow Chart

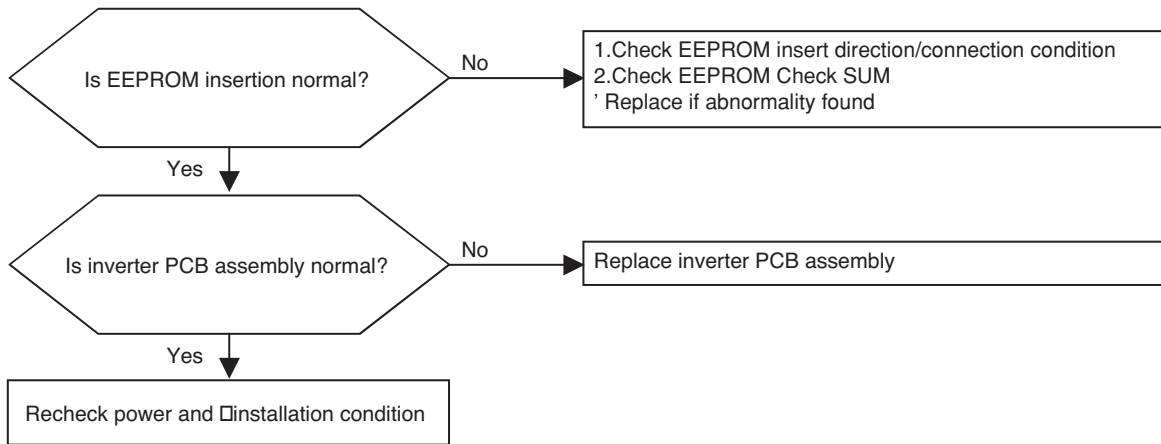

* Inverter EEPROM inserting point



EEPROM enlarged picture

* Right inserting direction of inverter EEPROM

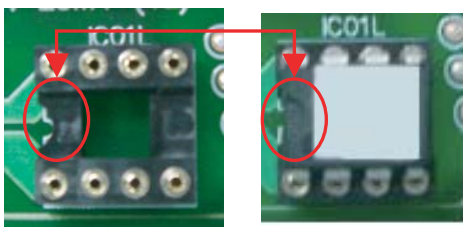

* Note : Replace after power off

Error No.	Error Type	Error Point	Main Reasons
67* Master 671 Slave1 672 Slave2 673 Slave3 674	Fan Lock Error	Fan RPM is 10RPM or less for 5 sec. when ODU fan starts or 40 RPM or less after fan starting.	<ol style="list-style-type: none"> 1. Fan motor defect / assembly condition abnormal 2. Wrong connection of fan motor connector (Hall sensor, U,V,W output) 3. Reversing rotation after RPM target apply 4. Fan PCB assembly defect 5. Fan lock by Heavy Snowfall.

■ Error Diagnosis and Countermeasure Flow Chart

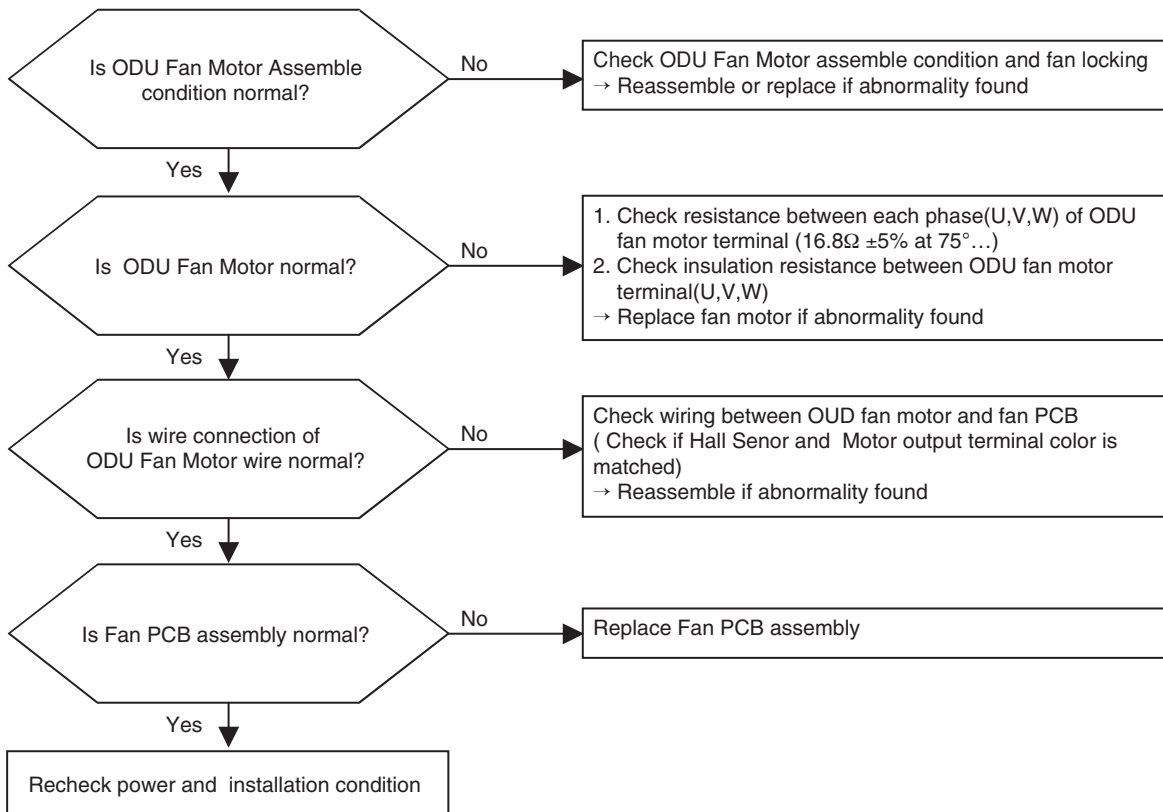

* Fan Motor resistance measuring between each phase

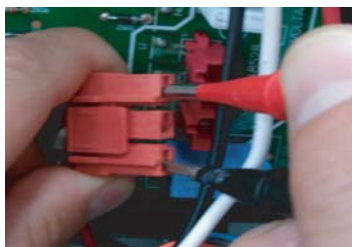

* Hall Sensor connector

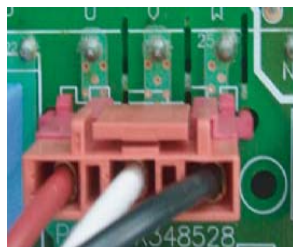

* Fan Motor Wire connection

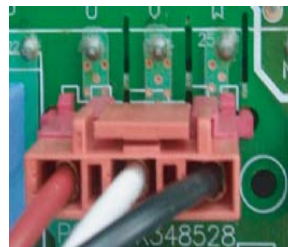

Error No.	Error Type	Error Point	Main Reasons
69* Master 691 Slave1 692 Slave2 693 Slave3 694	Constant 1 CT Sensor Error of Outdoor Unit	Constant 1 CT Sensor open or short of Outdoor Unit	Constant 1 CT Sensor Error
70* Master 701 Slave1 702 Slave2 703 Slave3 704	Constant Speed Compressor 2 CT Sensor Error	Constant Speed Compressor 2 CT Sensor Open/short	1. Constant Speed Compressor 2 CT Sensor defect

■ Error Diagnosis and Countermeasure Flow Chart

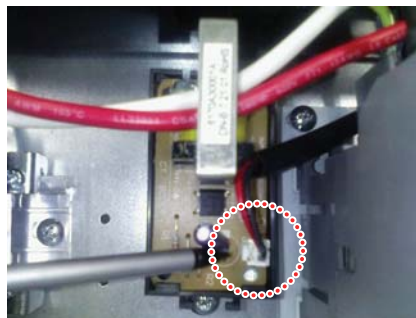
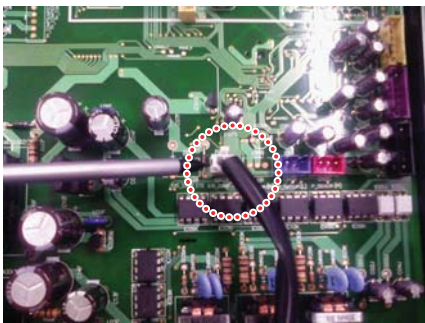
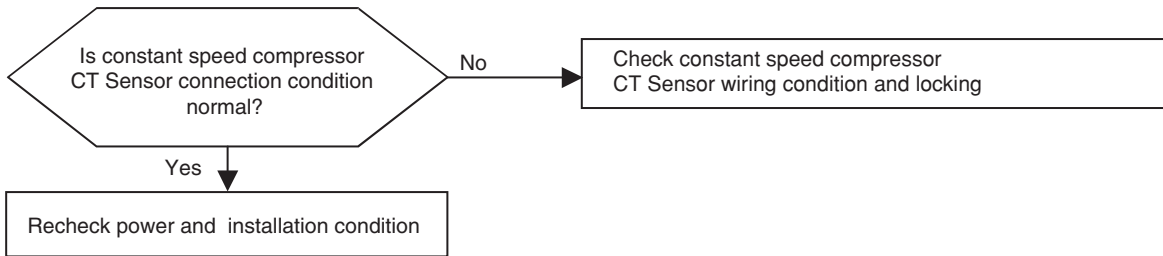

Error No.	Error Type	Error Point	Main Reasons
73* Master 731 Slave1 732 Slave2 733 Slave3 734	AC input instant over current error (Matter of software)	Inverter PCB input 3 phase power current is over 50A(peak) for 2ms	1. Overload operation (Pipe clogging/Covering/EEV defect/Ref. overcharge) 2. Compressor damage (Insulation damage/Motor damage) 3. Input voltage abnormal (R,S,T,N) 4. Power line assemble condition abnormal 5. Inverter PCB assembly damage (input current sensing part)

■ Error Diagnosis and Countermeasure Flow Chart

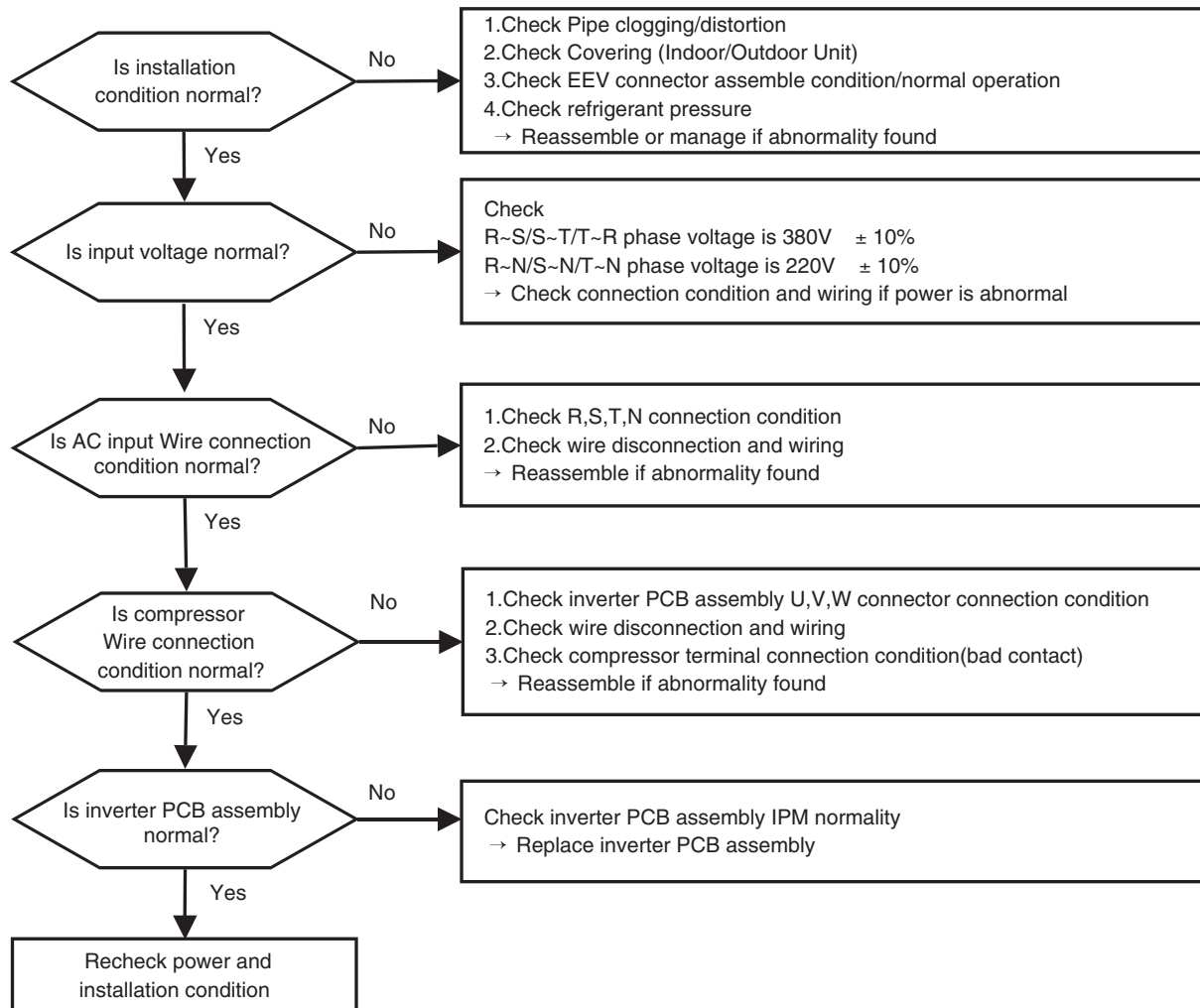

Measuring input voltage

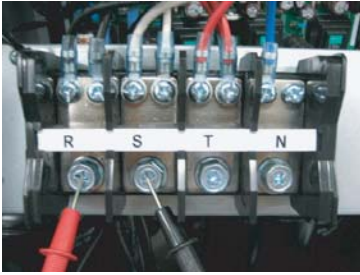

Compressor Wire Connection

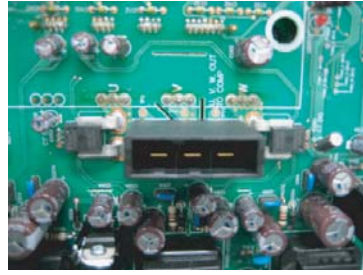

Noise filter wiring

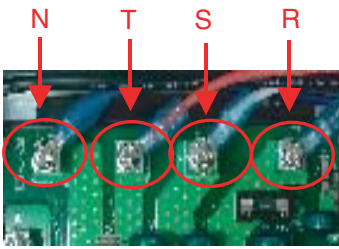

Noise filter input (upper part)

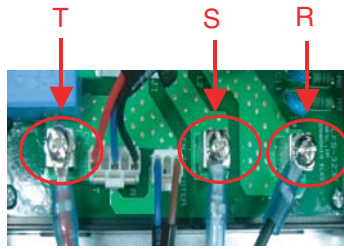

Noise filter output(lower part)

Inverter PCB assembly/Wiring power to inverter PCB on Noise filter



Inverter PCB assembly power connection



Noise filter power connection

Error No.	Error Type	Error Point	Main Reasons
75* Master 751 Slave1 752 Slave2 753 Slave3 754	Fan CT sensor error	Offset of micom which senses the fan motor phase current is not 2.5V	1. Input voltage is abnormal(not 15V) 2. Fan PCB assembly defect 3. Power wire open and connecting fault 4. Inv PCB assembly defect

■ Error Diagnosis and Countermeasure Flow Chart

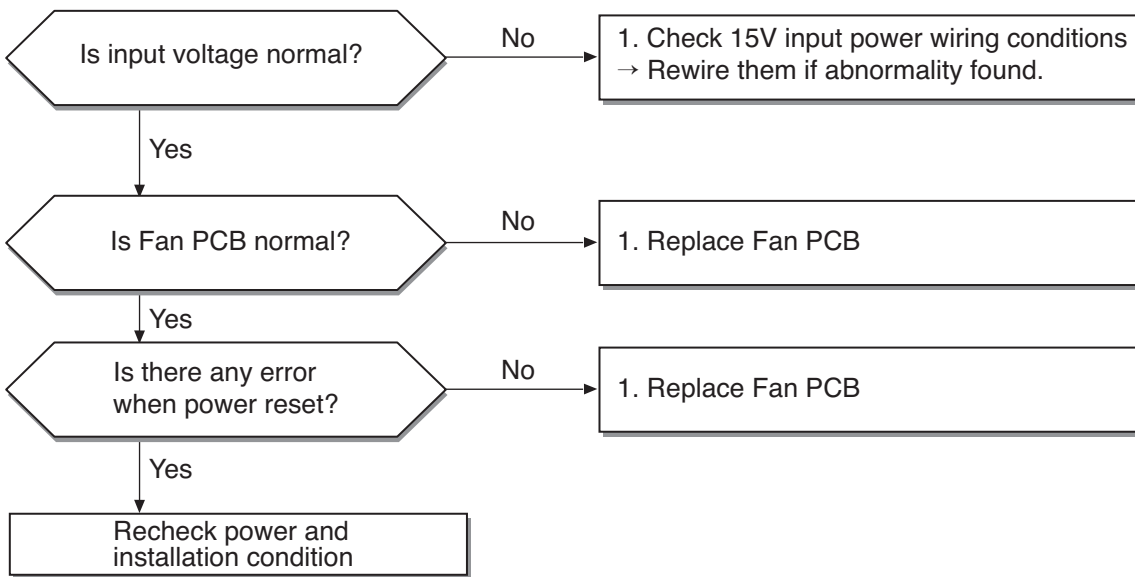

15V input power wiring conditions



15V input power on Inverter PCB

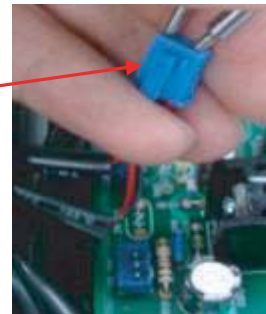

Check short of power wire

Error No.	Error Type	Error Point	Main Reasons
76* Master 761 Slave1 762 Slave2 763 Slave3 764	Fan DC Link High Voltage Error	Fan PCB DC link voltage supplied over 780V	1. Input power abnormal 2. Fan PCB assembly defect 3. Power wire connecting fault

■ Error Diagnosis and Countermeasure Flow Chart

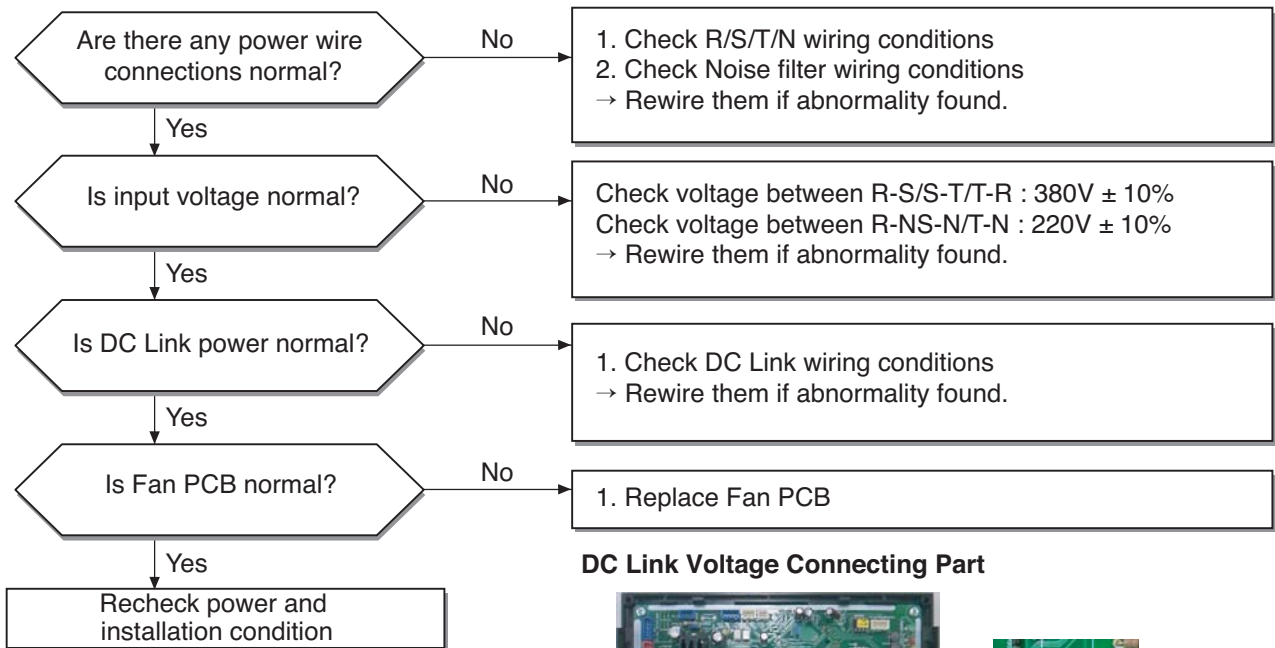

DC Link Voltage Connecting Part

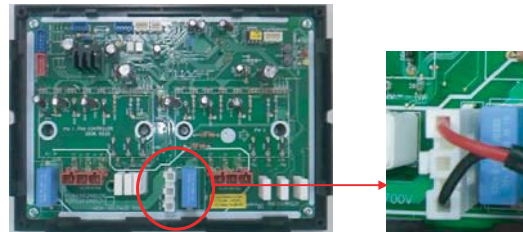

Noise filter wiring

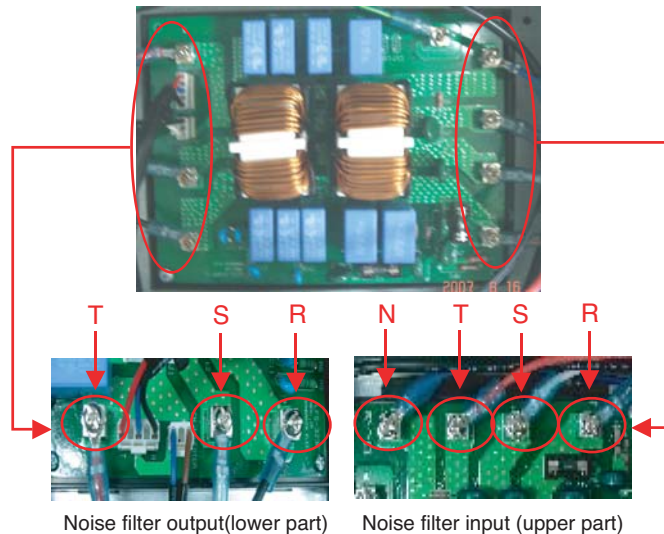

Error No.	Error Type	Error Point	Main Reasons
77* Master 771 Slave1 772 Slave2 773 Slave3 774	Fan Over Current Error	Output current is over 5A for 40ms	1. Overload operation 2. Fan Motor defect 3. Fan PCB assembly defect 4. Fan Motor connector insert defect 5. Condenser icing or blocking

■ Error Diagnosis and Countermeasure Flow Chart

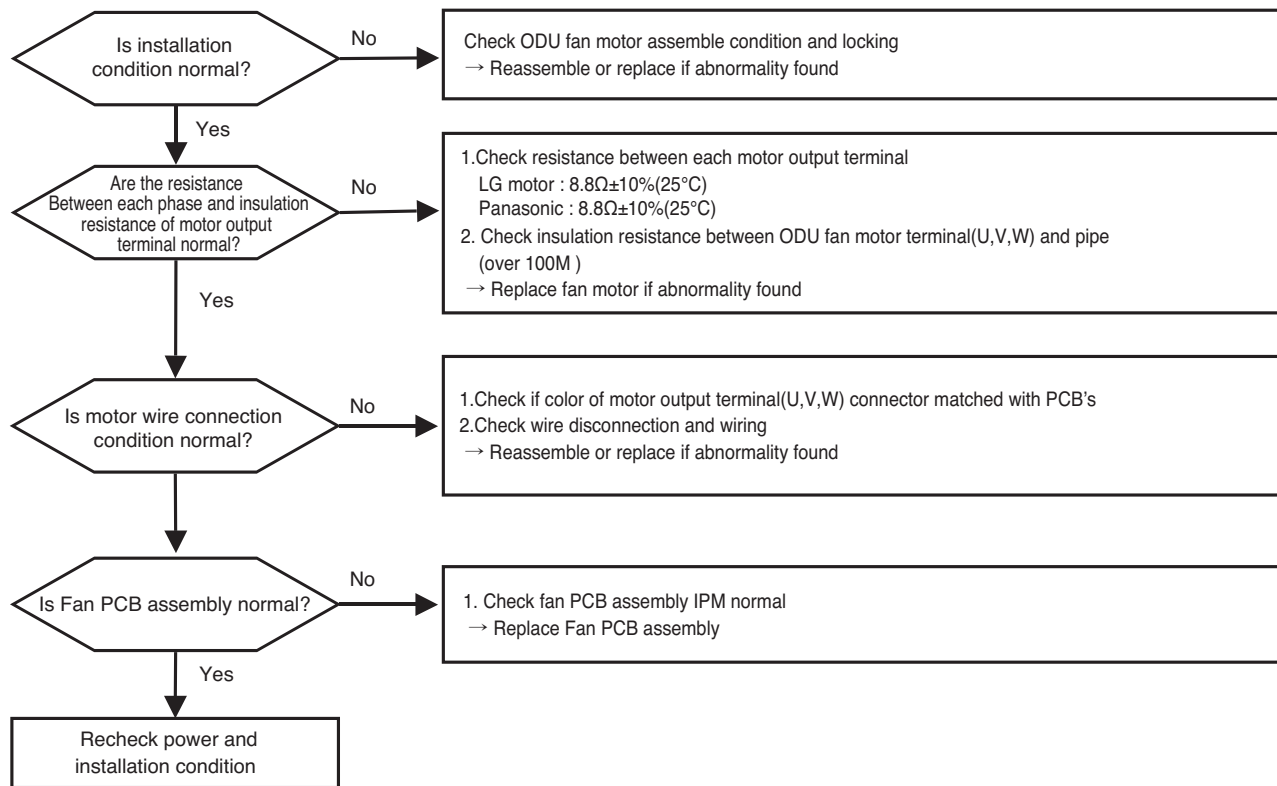

Measuring fan motor phase resistance

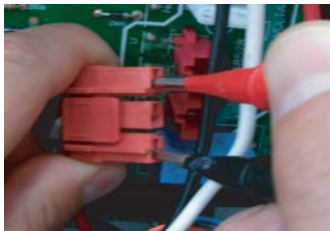

Fan motor wire connection

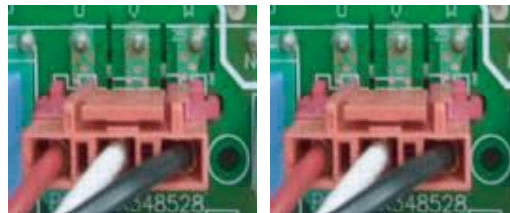

Error No.	Error Type	Error Point	Main Reasons
79* Master 791 Slave1 792 Slave2 793 Slave3 794	Fan Starting Failure Error	Fan Motor initial starting failure	1.Fan motor defect/ assemble condition abnormal 2.Fan motor connector misconnection(Hall sensor, U,V,W ouput) 3.Fan PCB defect

■ Error Diagnosis and Countermeasure Flow Chart

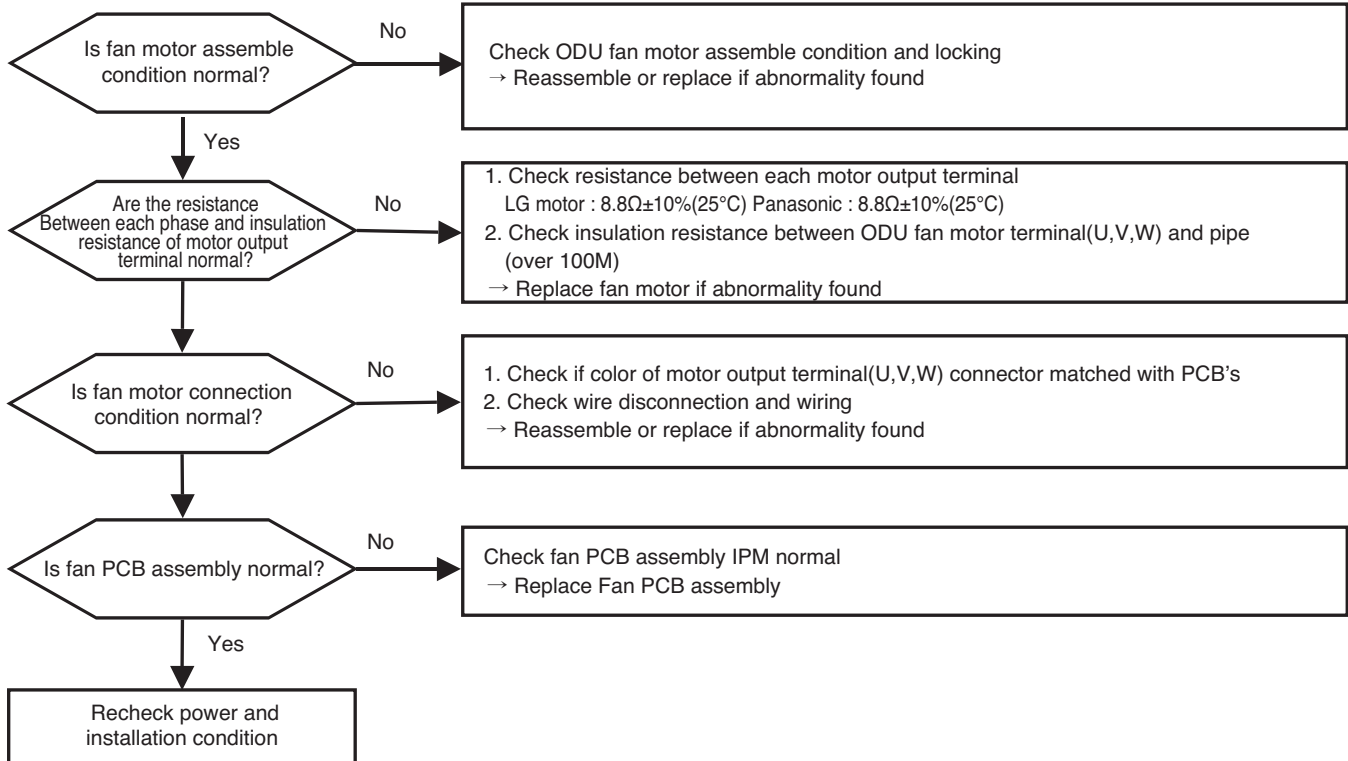

Measuring fan motor phase resistance

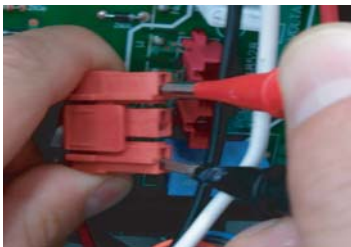

Measuring insulation resistance between fan terminal & chassis



Check

Fan motor wire connection

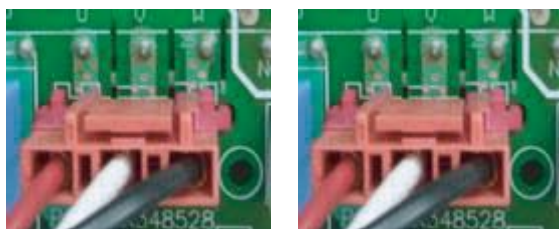

Error No.	Error Type	Error Point	Main Reasons
86* Master 861 Slave1 862 Slave2 863 Slave3 864	Main PCB EEPROM Error	EEPROM Access Error	1. No EEPROM 2. EEPROM wrong insertion

■ Error Diagnosis and Countermeasure Flow Chart

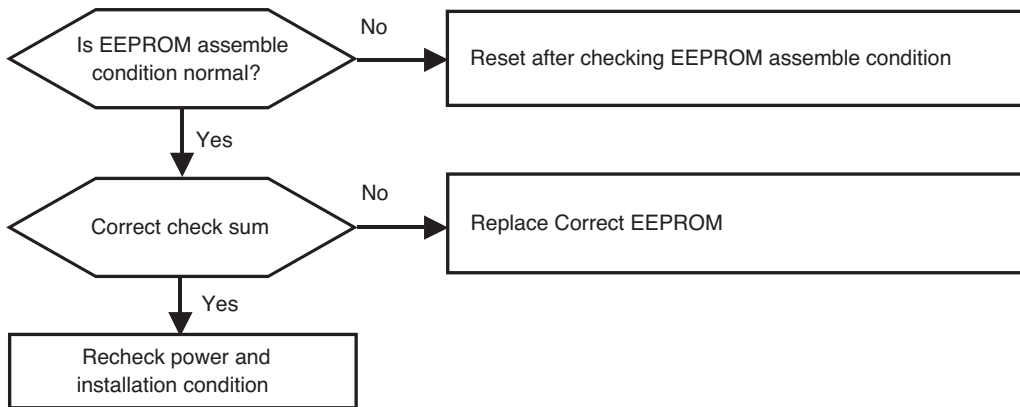

EEPROM insertion direction

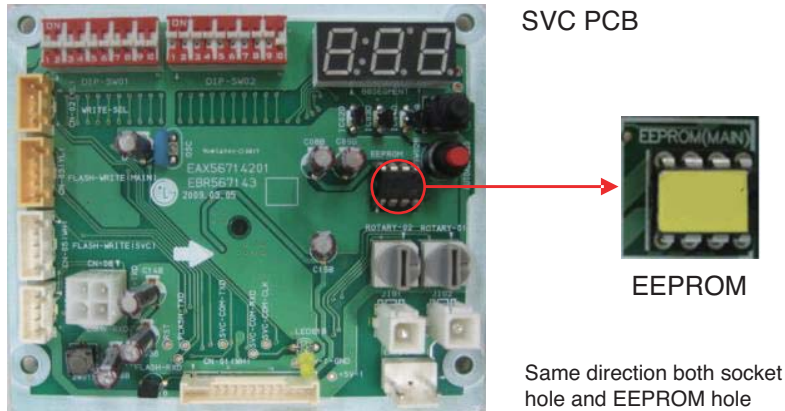

※ Note : Replace after power off

EEPROM insertion

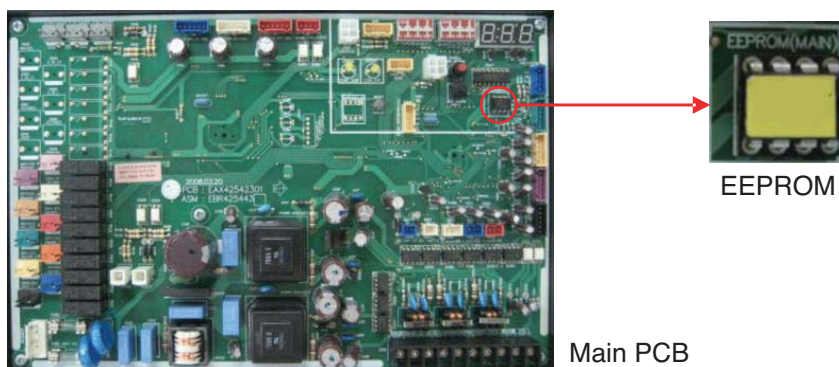

Error No.	Error Type	Error Point	Main Reasons
87* Master 871 Slave1 872 Slave2 873 Slave3 874	Fan PCB EEPROM Error	Error occurs when checking the EEPROM checksum as initializing after power is supplied	1.EEPROM bad contact/wrong insertion 2.EEPROM Version is different 3.ODU fan PCB assembly damage

■ Error Diagnosis and Countermeasure Flow Chart

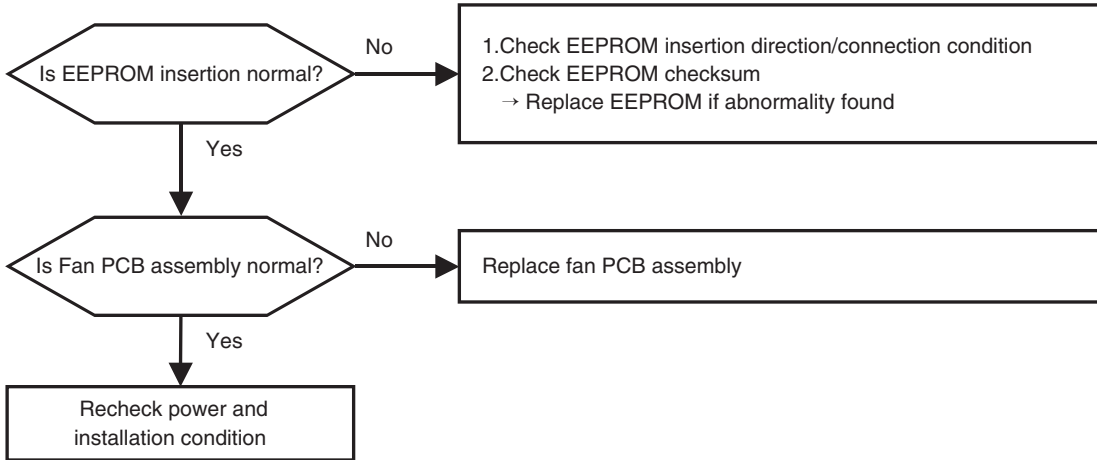

Fan EEPROM insertion

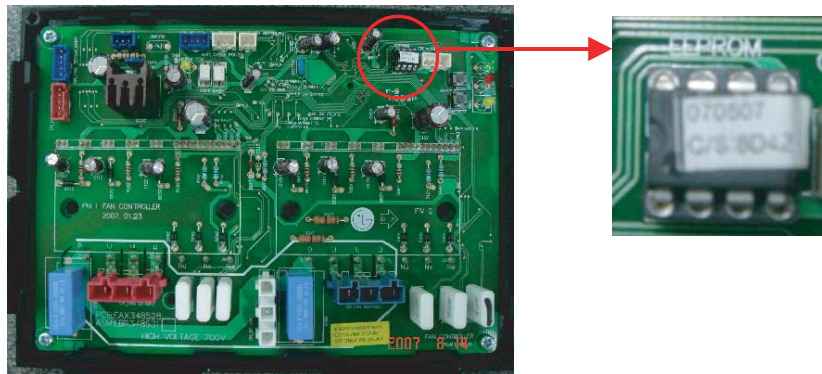

Inverter EEPROM insertion direction

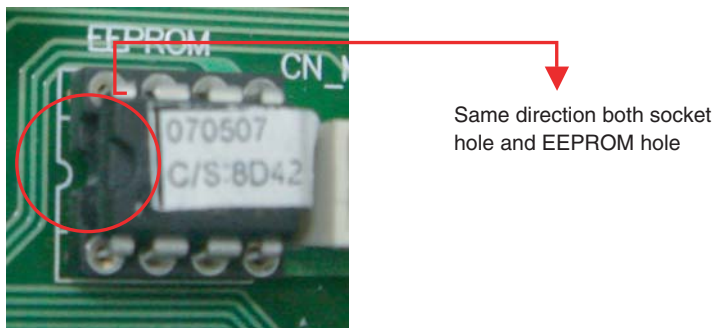

* Note : Replace after power off

Error No.	Error Type	Error Point	Main Reasons
104* Master 11 → 041 Slave1 12 → 042 Slave2 13 → 043 Slave3 14 → 044	Communication Error Between Outdoors	Master displays ODU number which is not communicated. Slave displays own error number	1. Loose connection of power cable/ communi- cation cable, (Open/Short) 2. Defect of each outdoor unit PCB

■ Error Diagnosis and Countermeasure Flow Chart

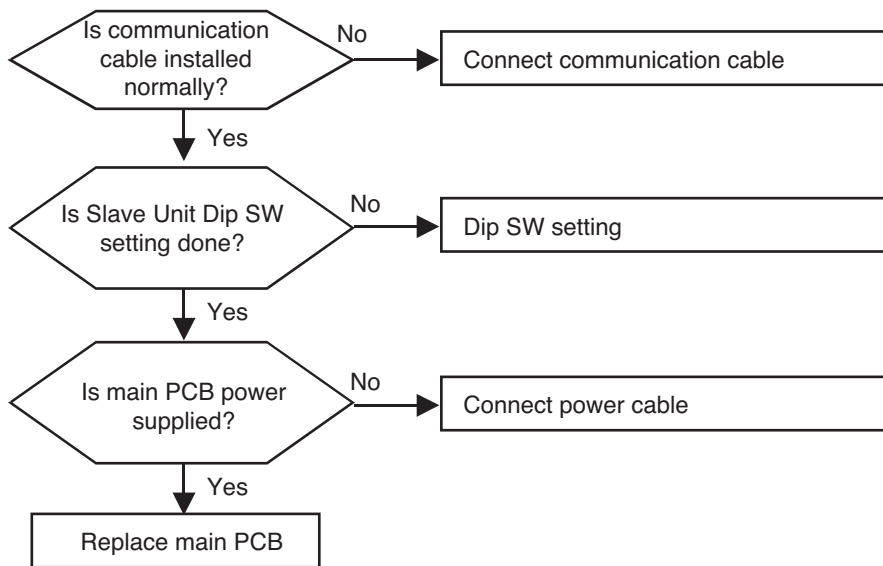

* Slave Unit Dip SW

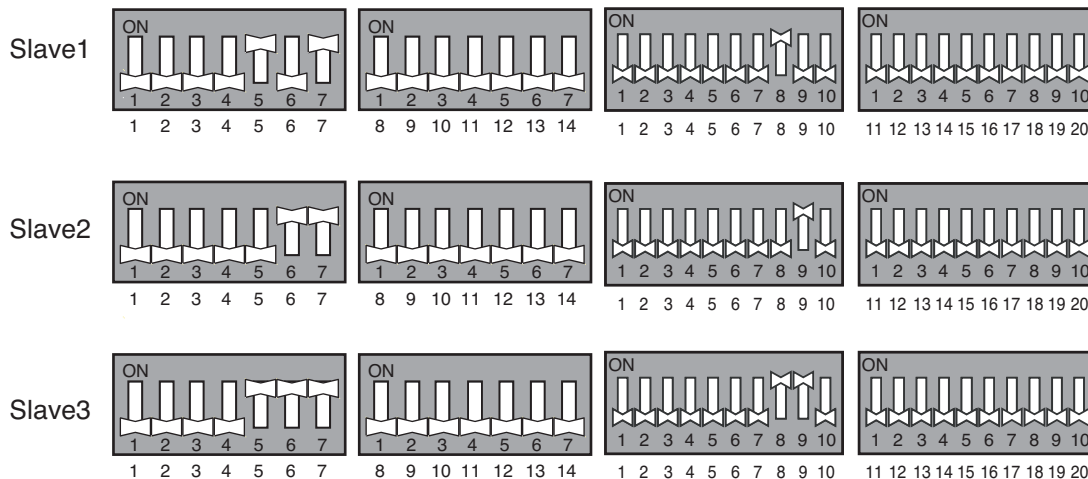

Error No.	Error Type	Error Point	Main Reasons
105* Master 11 → 051 Slave1 12 → 052 Slave2 13 → 053 Slave3 14 → 054	Communication error (Fan PCB ↔ Inverter PCB)	Fan controller didn't receive signal from inverter controller	1. Wrong connection between Inverter and Fan PCB 2. Fan PCB power not supplied 3. ODU Inv/Fan PCB defect

■ Error Diagnosis and Countermeasure Flow Chart

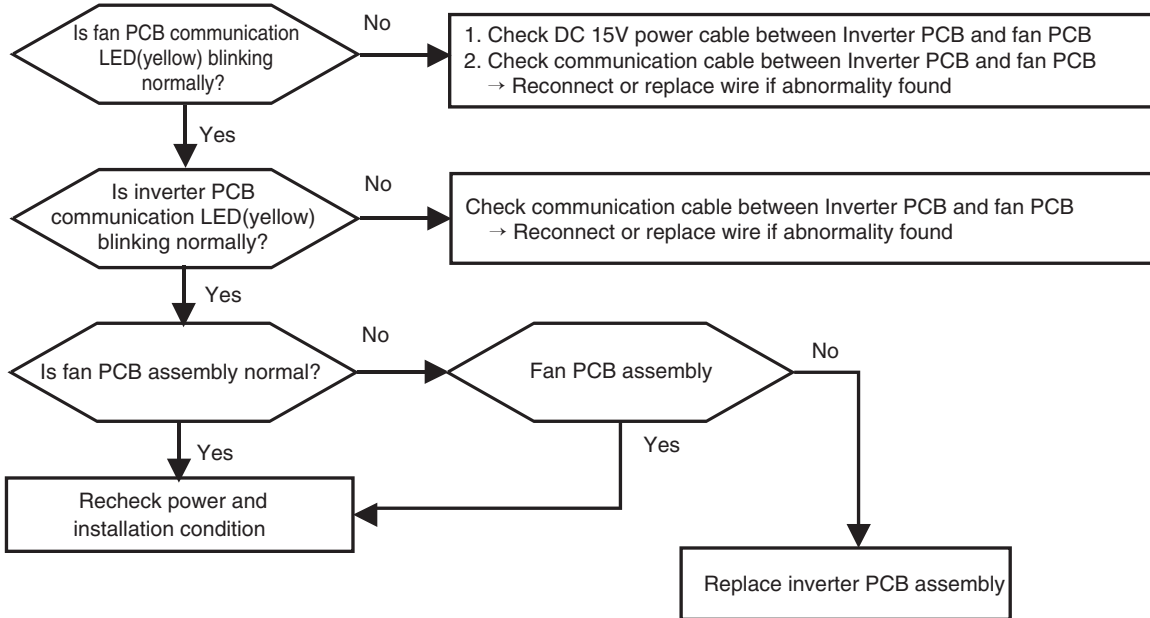

Checking 15V input

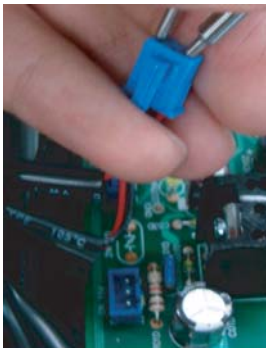

Fan communication connection

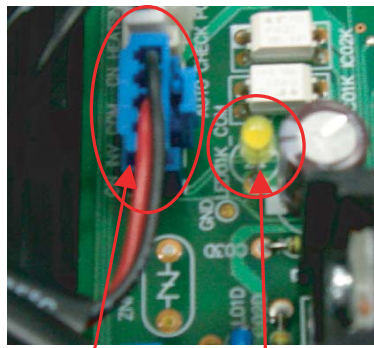

Communication connector Communication LED

Fan Error LED

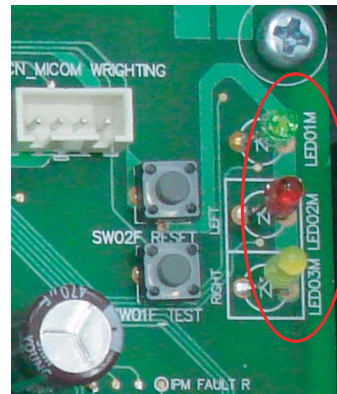

Error LED

* Note : Check fan PCB assembly Error LED blinking (Check 108π Error)

Error No.	Error Type	Error Point	Main Reasons
106* Master 11 → 061 Slave1 12 → 062 Slave2 13 → 063 Slave3 14 → 064	ODU Fan PCB IPM Fault	IPM protection circuit activation (over current / overheating)	<ol style="list-style-type: none"> 1. Overload operation (Pipe clogging/Covering/EEV defect/Ref. overcharge) 2. ODU fan motor assemble condition abnormal (Coil disconnection/Short/Insulation damage) 3. Fan PCB heatsink assemble condition abnormal 4. Fan PCB assembly defect

■ Error Diagnosis and Countermeasure Flow Chart

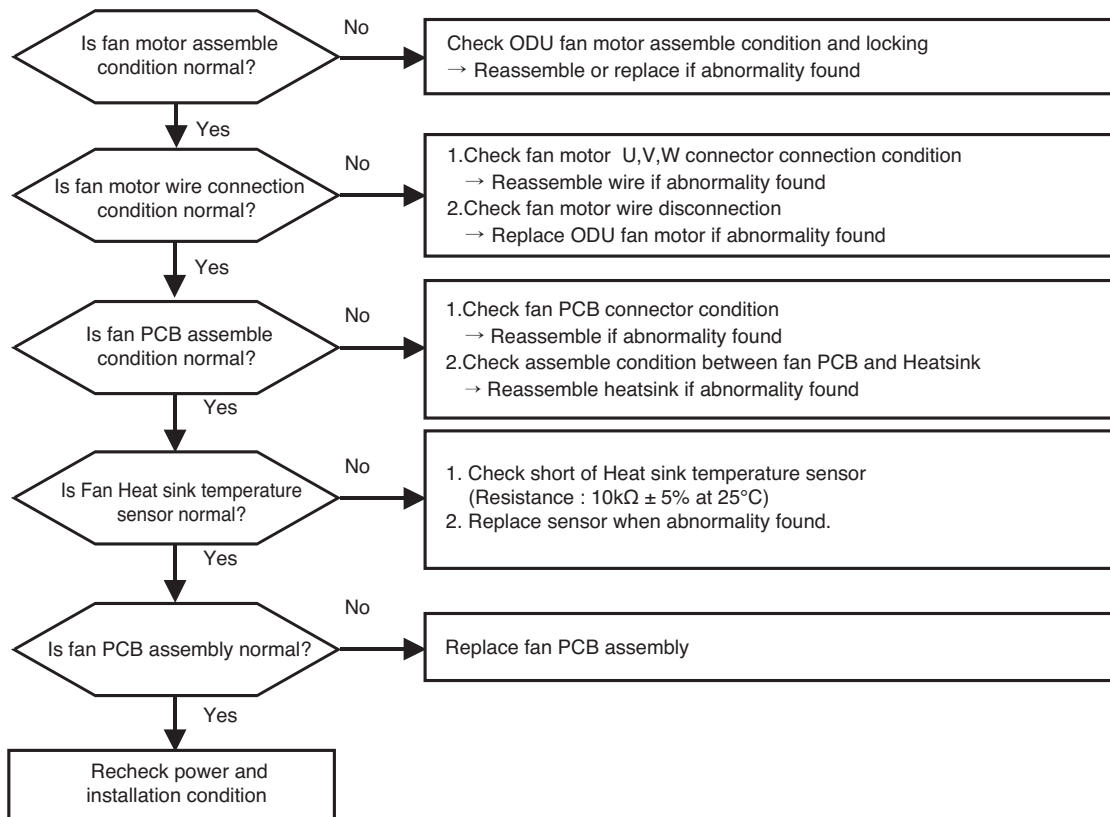

Fan Motor Wire connection

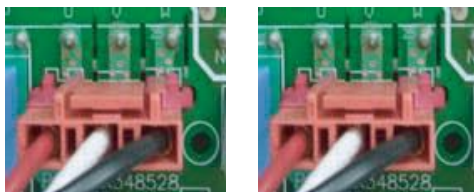

Fan IPM assemble position



Check assemble condition

Fan Heatsink assemble position



Check assemble condition

Error No.	Error Type	Error Point	Main Reasons
107* Master 11 → 071 Slave1 12 → 072 Slave2 13 → 073 Slave3 14 → 074	Fan DC Link Low Voltage Error	Fan PCB DC link voltage supplied below 380V	<ol style="list-style-type: none"> 1. Wrong wiring between inverter PCB and Fan PCB 2. Fan PCB assembly defect 3. Reactor terminal contact defect 4. DC link terminal wiring/contact defect 5. Bridge diode defect

■ Error Diagnosis and Countermeasure Flow Chart

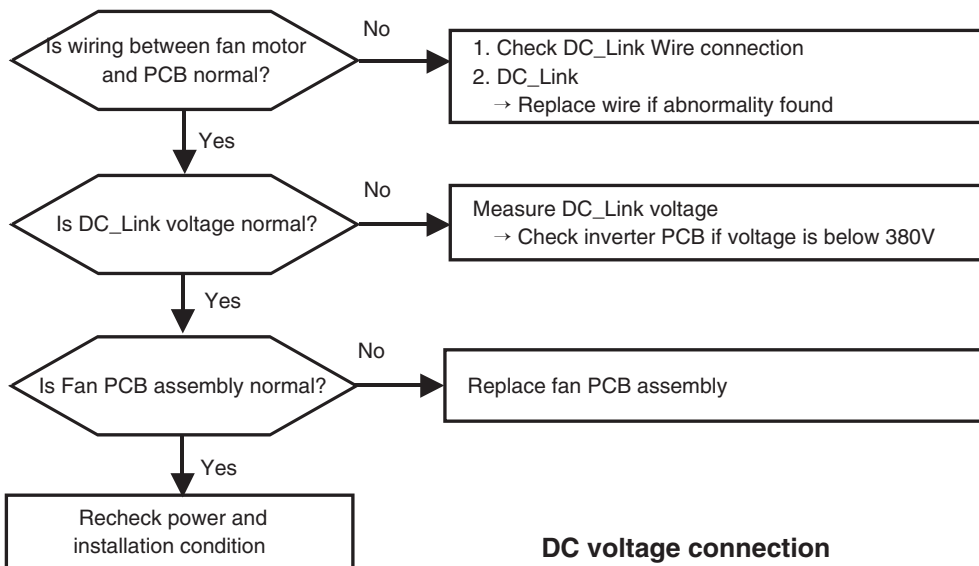

DC voltage connection

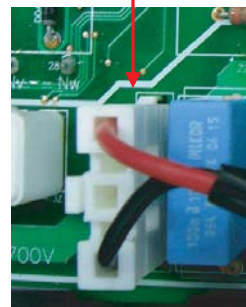
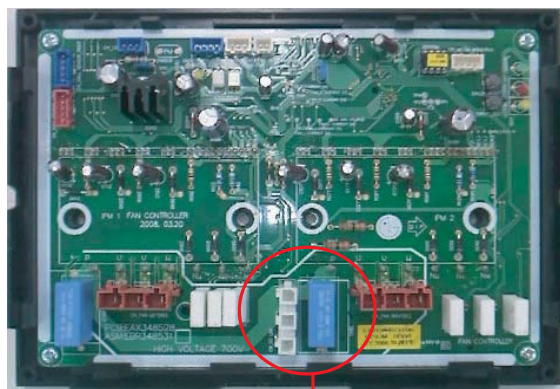

DC Volt connected

Error No.	Error Type	Error Point	Main Reasons
113* Master 11 → 131 Slave1 12 → 132 Slave2 13 → 133 Slave3 14 → 134	Outdoor unit liquid pipe (condenser) temperature sensor error	Abnormal sensor resistance value (Open/Short)	1. Defective temperature sensor connection 2. Defective temperature sensor (Open / Short) 3. Defective outdoor unit PCB

Error No.	Error Type	Error Point	Main Reasons
115* Master 11 → 151 Slave1 12 → 152 Slave2 13 → 153 Slave3 14 → 154	Outdoor Unit Subcooling Outlet Temperature Sensor Error	Abnormal sensor resistance value (Open/Short)	1. Defective temperature sensor connector connection 2. Defective temperature sensor (Open/Short) 3. Defective outdoor PCB

■ Error diagnosis and countermeasure flow chart

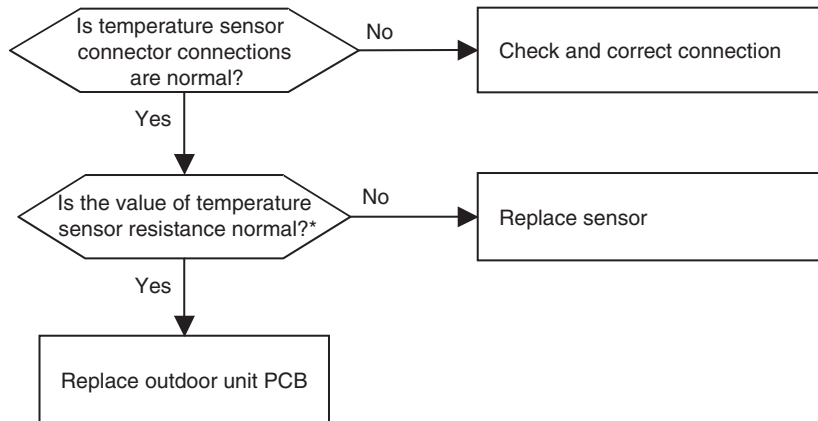

* Sensor resistance 100 kΩover (open) or 100 Ω below (short) will generate error

Note: Temperate sensor resistance vary with temperature, So compare temperature sensor resistance value according to outdoor unit temperature by referring below table (±5% tolerance)

Air temperature sensor: 10°C = 20.7kΩ : 25°C = 10kΩ : 50°C= 3.4kΩ

Pipe temperature sensor: 10°C = 10kΩ : 25°C = 5kΩ : 50°C= 1.8kΩ

Error No.	Error Type	Error Point	Main Reasons
151* Master 11→511	Function error of outdoor 4way (reversing valve)	Function error of 4way (reversing valve) in Main or Slave outdoor units	1. Wrong operation of 4way valve because of sludge etc. inflow 2. No pressure difference because of compressor fault 3. Wrong installation of In/outdoor common pipe 4. Defect of 4way valve

■ Error diagnosis and countermeasure flow chart

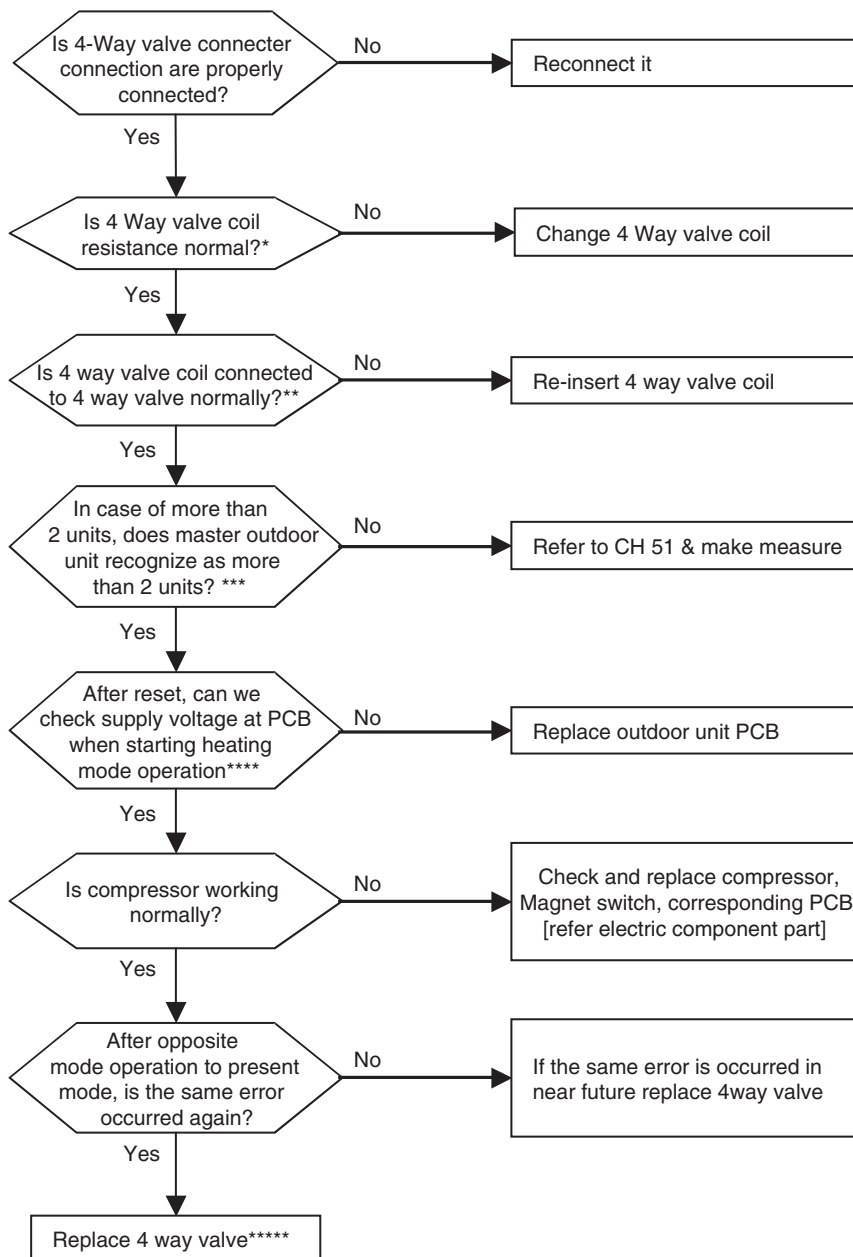

* Measure the resistance of 4way valve

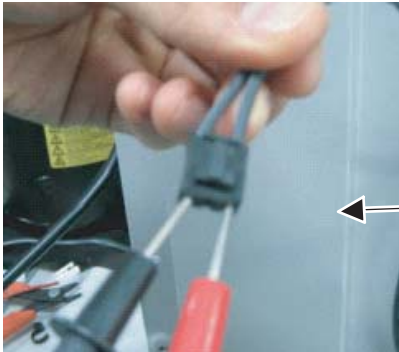

Location of 4way valve connector on Main PCB(marked as 4way,CN09)

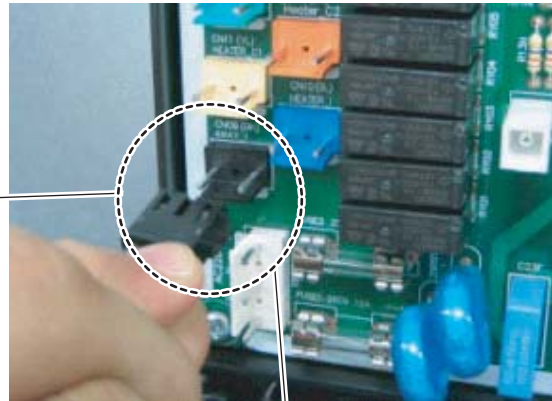

** Confirm the 4way valve coil is inserted to the end



**** Check the output voltage of terminal socket during heating operation

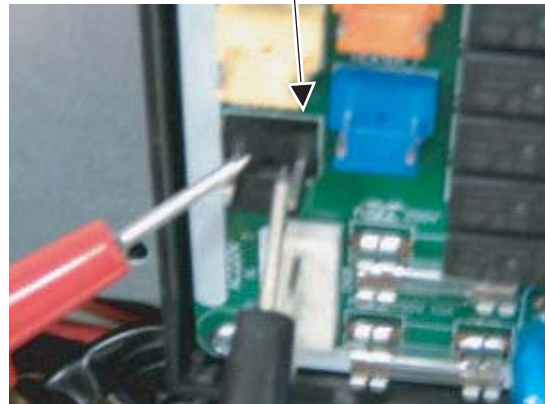

*** When power is supplied in order as follow
(Slave2 → Slave1 → Mater)
ODU information is displayed one after the other at main PCB 7-segment

1. Model ID
→ 5HP:60 , 6HP:61 , 8HP:62 , 10HP:63, 12HP:64, 14HP:65
2. Total Capacity
→ Displayed with HP
3. ODU Type
→ HEAT PUMP : 2, Cooling : 0
4. Normal mode : 25
5. Refrigerant
→ R410a : 41

***** Checking method for outdoor unit of 3unit system
(Master + Slave1 + Slave2)

- ① Close all the SVC valves of high / low pressure common pipe
- ② Operate system
- ③ Check the difference of high and low pressure with LGMV for each unit (Master, Slave1, Slave2)
- ④ If there is a unit in which the difference is not increased then the 4way valve of that unit is defective

Error No.	Error Type	Error Point	Main Reasons
173* Master 11-> 731 Slave1 12-> 732 Slave2 13-> 733 Slave3 14-> 734	Outdoor Unit Constant Speed Compressor 1 Over Current	Outdoor Unit Constant Speed Compressor 1 Fault or Drive Fault	1. Constant speed compressor 1 damage 2. Constant speed compressor 1 input over current 3. Discharge temperature sensor defect
174* Master 11-> 741 Slave1 12-> 742 Slave2 13-> 743 Slave3 14-> 744	Outdoor Unit Constant Speed Compressor 2 Over Current	Outdoor Unit Constant Speed Compressor 2 Fault or Drive Fault	1. Constant speed compressor 2 damage 2. Constant speed compressor 2 input over current 3. Discharge temperature sensor defect

■ Error diagnosis and countermeasure flow chart

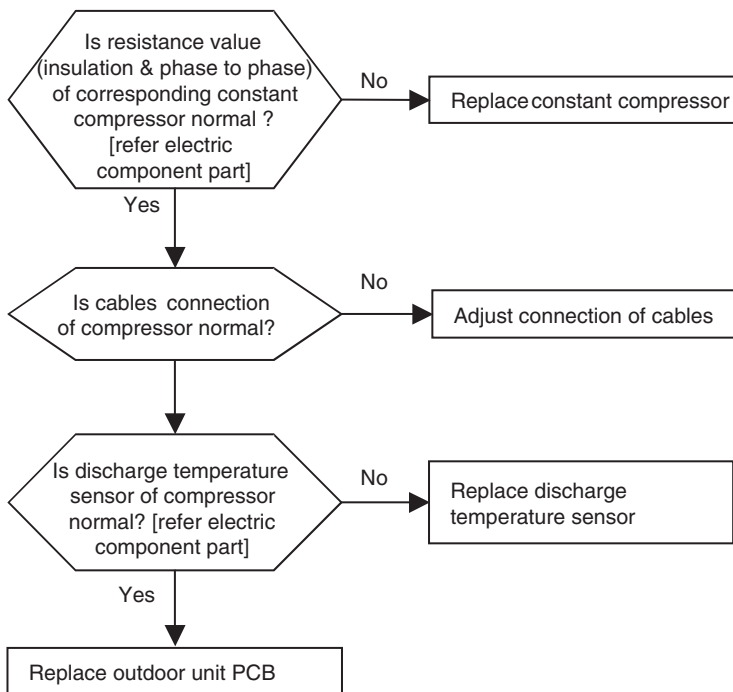

* cables connection between constant compressor and magnetic switch

Troubleshooting Guide

Error No.	Error Type	Error Point	Main Reasons
182* Master 11-> 821 Slave1 12-> 822 Slave2 13-> 823 Slave3 14-> 824	Communication Error Between Main-Sub Micom of Master Outdoor unit Main PCB	Failure Receiving Signal Between Main-Sub Micom of Master Outdoor unit Main PCB	1. Failure Receiving Signal Between Main-Sub Micom of Master Outdoor unit Main PCB

■ Error diagnosis and countermeasure flow chart

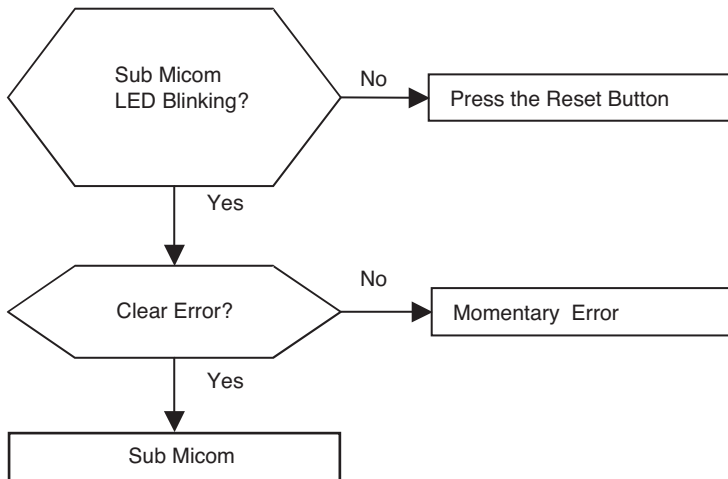

[Heat Pump]

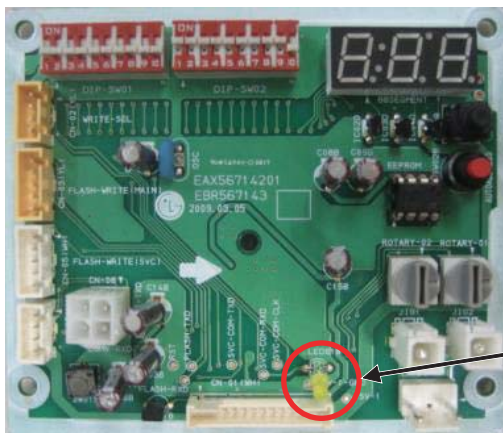

[Cooling Only]

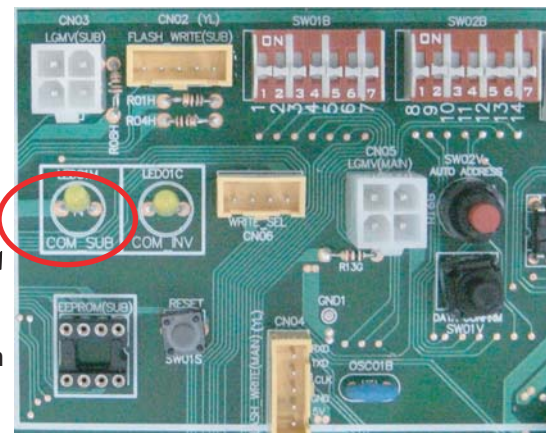

Sub Micom

Error No.	Error Type	Error Point	Main Reasons
184* Master (11-841) Slave1 (12-842) Slave2 (13-843) Slave3 (14-844)	Oil equalizing pipe temperature sensor error	Oil balance pipe temperature sensor Open or short	1. Bad connection of air temperature connector 2. Defect of oil temperature connector (Open/Short) 3. Defect of outdoor PCB
185* Master (11-851) Slave1 (12-852) Slave2 (13-853) Slave3 (14-854)	Oil equalizing pipe temperature sensor error	Oil balance pipe temperature sensor Open or short	1. Bad connection of air temperature connector 2. Defect of oil temperature connector (Open/Short) 3. Defect of outdoor PCB
186* Master (11-861) Slave1 (12-862) Slave2 (13-863) Slave3 (14-864)	Oil equalizing pipe temperature sensor error	Oil balance pipe temperature sensor Open or short	1. Bad connection of air temperature connector 2. Defect of oil temperature connector (Open/Short) 3. Defect of outdoor PCB

■ Error diagnosis and countermeasure flow chart

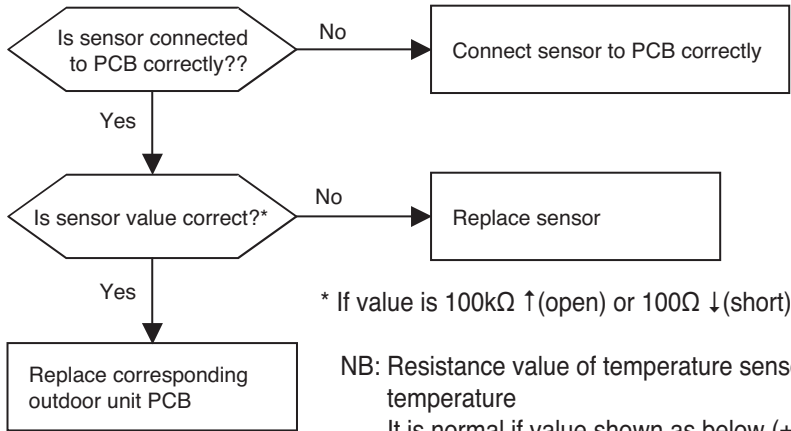

* If value is 100kΩ ↑(open) or 100Ω ↓(short), error occurs

NB: Resistance value of temperature sensor change according to temperature

It is normal if value shown as below (±5% error)

Sensor of air temperature: 10°C = 20.7kΩ : 25°C= 10kΩ : 50°C= 3.4kΩ

Sensor of piping temperature: 10°C = 10kΩ : 25°C= 5kΩ : 50°C= 1.8kΩ

Error No.	Error Type	Error Point	Main Reasons
193* Master 11 → 931 Slave1 12 → 932 Slave2 13 → 933 Slave3 14 → 934	Fan PCB heatsink temperature high	Heat sink temperature is over 95°C	1. Heatsink temperature sensor defect 2. Fan PCB assembly defect
194* Master 11 → 941 Slave1 12 → 942 Slave2 13 → 943 Slave2 14 → 944	Fan PCB heatsink temperature sensor error	Heatsink temperature sensor abnormal	1. Heatsink temperature sensor defect(Open/Short) 2. Wrong connection of temperature sensor connector 3. Fan PCB assembly defect

■ Error diagnosis and countermeasure flow chart

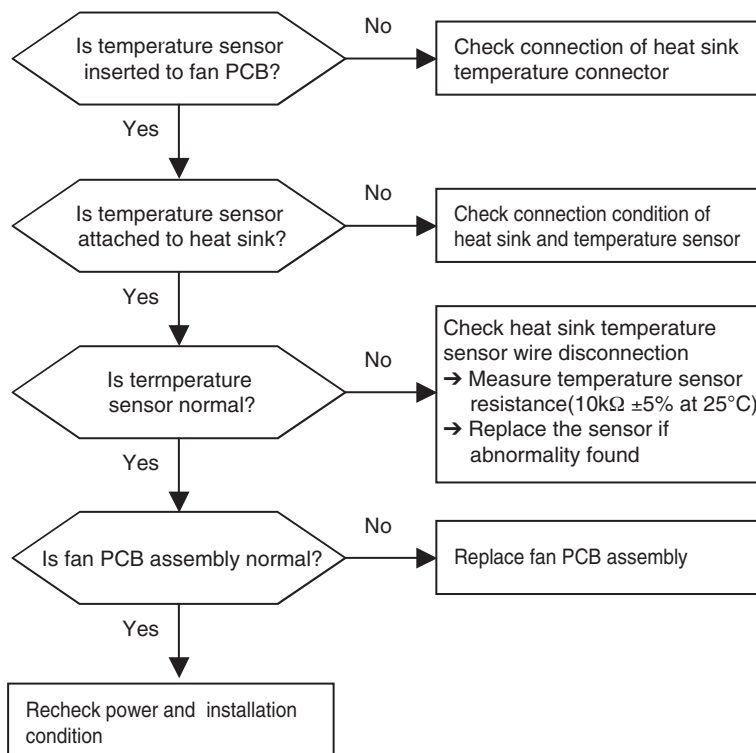

Fan heat sink connection



Check connection condition

Checking temperature sensor disconnection



Error No.	Error Type	Error Point	Main Reasons
242	Network Error	Network error of central controller	1. RS-485 communication wiring defect 2. Communication defect between remote controller and indoor unit 3. RS-485 dip switch setting error 4. Indoor unit addressing ssetting error on central controller

■ Error diagnosis and countermeasure flow chart

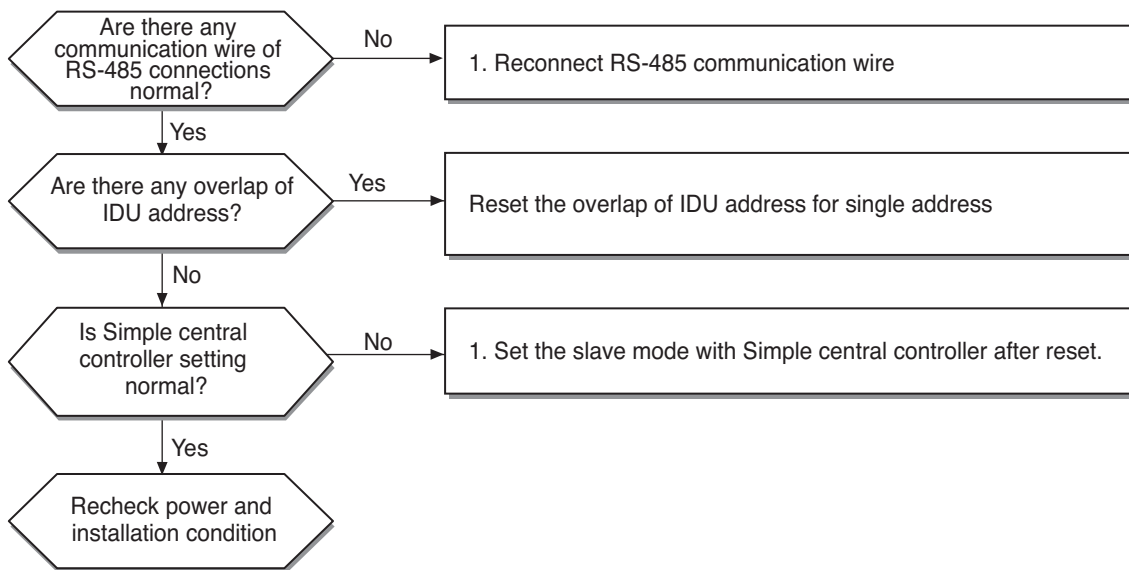

<RS-485 communication wire miss connection>

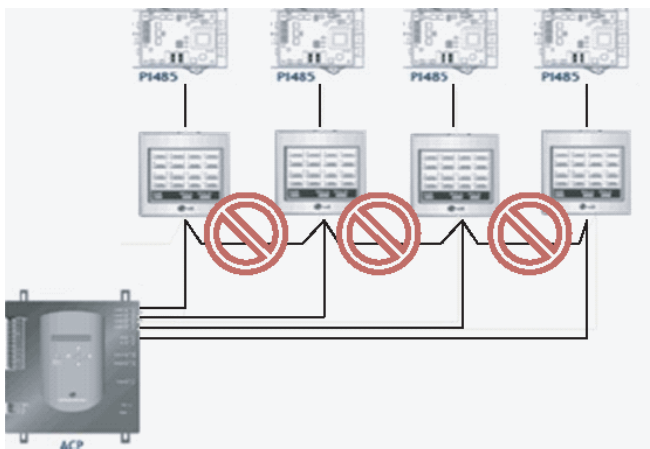



P/NO : MFL54555506

APRIL, 2010