



Internal Use Only

<http://biz.lgservice.com>

# ***MULTI V***™ **IV** **Outdoor Unit** **R410A** **SERVICE MANUAL**

## **CAUTION**

Before Servicing the unit, read the safety precautions in General SVC manual.  
Only for authorized service personnel.

# TABLE OF CONTENTS

<b>Safety Precautions</b> .....	3
<b>Part 1 General Information</b> .....	8
<b>Model Names</b> .....	9
<b>External Appearance</b> .....	11
<b>Combination of Outdoor Units</b> .....	13
<b>Nomenclature</b> .....	14
<b>Part 2 Outdoor Units</b> .....	16
<b>Part 3 HR Units</b> .....	50
<b>Part 4 PCB Setting and Test Run</b> .....	59
<b>Part 5 Trouble shooting guide</b> .....	77

# Safety Precautions



To prevent injury to the user or other people and property damage, the following instructions must be followed.

■ Incorrect operation due to ignoring instruction will cause harm or damage. The seriousness is classified by the following indications.

**⚠ WARNING** This symbol indicates the possibility of death or serious injury.

**⚠ CAUTION** This symbol indicates the possibility of injury or damage to properties only.

■ Meanings of symbols used in this manual are as shown below.

	<b>Be sure not to do.</b>
	<b>Be sure to follow the instruction.</b>

## ⚠ WARNING

### ■ Installation

**Have all electric work done by a licensed electrician according to "Electric Facility Engineering Standard" and "Interior Wire Regulations" and the instructions given in this manual and always use a special circuit.**

- If the power source capacity is inadequate or electric work is performed improperly, electric shock or fire may result.

**Always ground the product.**

- There is risk of fire or electric shock.

**For re-installation of the installed product, always contact a dealer or an Authorized Service Center.**

- There is risk of fire, electric shock, explosion, or injury.

**Ask the dealer or an authorized technician to install the air conditioner.**

- Improper installation by the user may result in water leakage, electric shock, or fire.

**Always install a dedicated circuit and breaker.**

- Improper wiring or installation may cause fire or electric shock.

**Do not install, remove, or re-install the unit by yourself (customer).**

- There is risk of fire, electric shock, explosion, or injury.

**Do not store or use flammable gas or combustibles near the air conditioner.**

- There is risk of fire or failure of product.

**Prepare for strong wind or earthquake and install the unit at the specified place.**

- Improper installation may cause the unit to topple and result in injury.

**When installing and moving the air conditioner to another site, do not charge it with a different refrigerant from the refrigerant specified on the unit.**

- If a different refrigerant or air is mixed with the original refrigerant, the refrigerant cycle may malfunction and the unit may be damaged.

**Ventilate before operating air conditioner when gas leaked out.**

- It may cause explosion, fire, and burn.

**If the air conditioner is installed in a small room, measures must be taken to prevent the refrigerant concentration from exceeding the safety limit when the refrigerant leaks.**

- Consult the dealer regarding the appropriate measures to prevent the safety limit from being exceeded. Should the refrigerant leak and cause the safety limit to be exceeded, hazards due to lack of oxygen in the room could result

**Use the correctly rated breaker or fuse.**

- There is risk of fire or electric shock.

**Do not install the product on a defective installation stand.**

- It may cause injury, accident, or damage to the product.

**Do not reconstruct to change the settings of the protection devices.**

- If the pressure switch, thermal switch, or other protection device is shorted and operated forcibly, or parts other than those specified by LGE are used, fire or explosion may result.

**Securely install the cover of control box and the panel.**

- If the cover and panel are not installed securely, dust or water may enter the outdoor unit and fire or electric shock may result.

**Use a vacuum pump or inert(nitrogen) gas when doing leakage test or air purge. Do not compress air or Oxygen and do not use flammable gas es. Otherwise, it may cause fire or explosion.**

- There is the risk of death, injury, fire or explosion.

## ■ Operation

### Do not damage or use an unspecified power cord.

- There is risk of fire, electric shock, explosion, or injury.

### Be cautious that water could not enter the product.

- There is risk of fire, electric shock, or product damage.

### When the product is soaked (flooded or submerged), contact an Authorized Service Center.

- There is risk of fire or electric shock.

### Take care to ensure that nobody could step on or fall onto the outdoor unit.

- This could result in personal injury and product damage.

### Use a dedicated outlet for this appliance.

- There is risk of fire or electrical shock.

### Do not touch the power switch with wet hands.

- There is risk of fire, electric shock, explosion, or injury.

### Be cautious not to touch the sharp edges when installing.

- It may cause injury.

### Do not open the inlet grille of the product during operation. (Do not touch the electrostatic filter, if the unit is so equipped.)

- There is risk of physical injury, electric shock, or product failure.

## ⚠ CAUTION

## ■ Installation

### Always check for gas (refrigerant) leakage after installation or repair of product.

- Low refrigerant levels may cause failure of product.

### Keep level even when installing the product.

- To avoid vibration or water leakage.

### Do not install the product where the noise or hot air from the outdoor unit could damage the neighborhoods.

- It may cause a problem for your neighbors.

### Do not install the unit where combustible gas may leak.

- If the gas leaks and accumulates around the unit, an explosion may result.

## Safety Precautions

---

### Use power cables of sufficient current carrying capacity and rating.

- Cables that are too small may leak, generate heat, and cause a fire.

### Keep the unit away from children. The heat exchanger is very sharp.

- It can cause the injury, such as cutting the finger. Also the damaged fin may result in degradation of capacity.

### Do not use the product for special purposes, such as preserving foods, works of art, etc. It is a consumer air conditioner, not a precision refrigeration system.

- There is risk of damage or loss of property.

### When installing the unit in a hospital, communication station, or similar place, provide sufficient protection against noise.

- The inverter equipment, private power generator, high-frequency medical equipment, or radio communication equipment may cause the air conditioner to operate erroneously, or fail to operate. On the other hand, the air conditioner may affect such equipment by creating noise that disturbs medical treatment or image broadcasting.

### Do not install the product where it is exposed to sea wind (salt spray) directly.

- It may cause corrosion on the product. Corrosion, particularly on the condenser and evaporator fins, could cause product malfunction or inefficient operation.

## ■ Operation

---

### Do not use the air conditioner in special environments.

- Oil, steam, sulfuric smoke, etc. can significantly reduce the performance of the air conditioner or damage its parts.

### Do not block the inlet or outlet.

- It may cause failure of appliance or accident.

### Make the connections securely so that the outside force of the cable may not be applied to the terminals.

- Inadequate connection and fastening may generate heat and cause a fire.

### Be sure the installation area does not deteriorate with age.

- If the base collapses, the air conditioner could fall with it, causing property damage, product failure, or personal injury.

**Install and insulate the drain hose to ensure that water is drained away properly based on the installation manual.**

- A bad connection may cause water leakage.

**Be very careful about product transportation.**

- Only one person should not carry the product if it weighs more than 20 kg.
- Some products use PP bands for packaging. Do not use any PP bands for a means of transportation. It is dangerous.
- Do not touch the heat exchanger fins. Doing so may cut your fingers.
- When transporting the outdoor unit, suspending it at the specified positions on the unit base. Also support the outdoor unit at four points so that it cannot slip sideways.

**Safely dispose of the packing materials.**

- Packing materials, such as nails and other metal or wooden parts, may cause stabs or other injuries.
- Tear apart and throw away plastic packaging bags so that children may not play with them. If children play with a plastic bag which was not torn apart, they face the risk of suffocation.

**Turn on the power at least 6 hours before starting operation.**

- Starting operation immediately after turning on the main power switch can result in severe damage to internal parts. Keep the power switch turned on during the operational season.

**Do not touch any of the refrigerant piping during and after operation.**

- It can cause a burn or frostbite.

**Do not operate the air conditioner with the panels or guards removed.**

- Rotating, hot, or high-voltage parts can cause injuries.

**Do not directly turn off the main power switch after stopping operation.**

- Wait at least 5 minutes before turning off the main power switch. Otherwise it may result in water leakage or other problems.

**Auto-addressing should be done in condition of connecting the power of all indoor and outdoor units. Auto-addressing should also be done in case of changing the indoor unit PCB.**

**Use a firm stool or ladder when cleaning or maintaining the air conditioner.**

- Be careful and avoid personal injury.

**Do not insert hands or other objects through the air inlet or outlet while the air conditioner is plugged in.**

- There are sharp and moving parts that could cause personal injury.

# Part 1

## General Information

<b>1. Model Names .....</b>	<b>9</b>
<b>1.1 Indoor Unit .....</b>	<b>9</b>
<b>1.2 Outdoor Unit .....</b>	<b>9</b>
<b>1.3 HR Unit .....</b>	<b>9</b>
<b>2. External Appearance .....</b>	<b>11</b>
<b>2.1 Indoor Unit .....</b>	<b>11</b>
<b>2.2 Outdoor Unit .....</b>	<b>12</b>
<b>3. Combination of Outdoor Units .....</b>	<b>13</b>
<b>4. Nomenclature.....</b>	<b>14</b>
<b>4.1 Indoor Unit .....</b>	<b>14</b>
<b>4.2 Outdoor Unit .....</b>	<b>14</b>
<b>4.3 HR Unit .....</b>	<b>15</b>

# 1. Model Names

## 1.1 Indoor Unit

Category		Chassis Name	Capacity(Btu/h(kW))														
			5k (1.6)	7k (2.2)	9k (2.8)	12k (3.6)	15k (4.5)	18k (5.6)	21k (6.2)	24k (7.1)	28k (8.2)	36k (10.6)	42k (12.3)	48k (14.1)	54k (15.8)	76k (22.4)	96k (28.0)
Wall Mounted	General	S5						0	0								
	Libero	SB		0	0	0	0										
		SC						0	0								
ART COOL	Mirror	SE		0	0	0	0										
		S8						0	0								
	Gallery	SF		0	0	0											
Ceiling Cassette	1 Way	TU		0	0	0											
		TT						0	0								
	2 Way	TL						0	0								
		4 Way	TR	0	0	0	0										
	TQ						0	0									
	TP									0	0						
	TN											0					
TM											0	0					
Ceiling Concealed Duct	High Static	BH		0	0	0	0	0		0							
		BG									0	0	0				
		BR												0	0		
		B8														0	0
	Low Static	L1	0	0	0												
		L2				0	0	0									
		L3								0	0						
	Built In (Low Static)	B3		0	0	0	0										
B4								0	0								
Ceiling & Floor		VE			0	0											
Ceiling Suspended		VJ						0	0								
		VK										0					
		VL												0			
Floor Standing	With Case	CE		0	0	0	0										
		CF							0	0							
	Without Case	CE		0	0	0	0										
		CF							0	0							
Console		QA		0	0	0	0										
Fresh Air Intake Unit		BR												0			
		B8														0	0

\* In matters of combination with Outdoor unit system, refer the PDB of that outdoor units.  
 \* ART COOL- SE/S8( \* R:Mirror, V:Silver), SF(\* E:Red, V:Silver, G:Gold, 1: Kiss (Photo changeable))  
 \*Wall Mounted- A: Basic, L:Plasma, \*Ceiling Cassette- A: Basic, C:Plasma

## 1.2 Outdoor Unit

Power Supply	8HP	10HP	12HP	14HP	16HP	18HP	20HP	22HP
380 V3N~ 60Hz 380-415 V3N~ 50Hz	080LTE4	100LTE4	120LTE4	140LTE4	160LTE4	180LTE4	200LTE4	220LTE4

Power Supply	24HP	26HP	28HP	30HP	32HP	34HP	36HP	38HP
380 V3N~ 60Hz 380-415 V3N~ 50Hz	240LTE4	260LTE4	280LTE4	300LTE4	320LTE4	340LTE4	360LTE4	380LTE4

Power Supply	40HP	42HP	44HP	46HP	48HP	50HP	52HP	54HP
380 V3N~ 60Hz 380-415 V3N~ 50Hz	400LTE4	420LTE4	440LTE4	460LTE4	480LTE4	500LTE4	520LTE4	540LTE4

Power Supply	56HP	58HP	60HP	62HP	64HP	66HP	68HP	70HP
380 V3N~ 60Hz 380-415 V3N~ 50Hz	560LTE4	580LTE4	600LTE4	620LTE4	640LTE4	660LTE4	680LTE4	700LTE4

Power Supply	72HP	74HP	76HP	78HP	80HP
380 V3N~ 60Hz 380-415 V3N~ 50Hz	720LTE4	740LTE4	760LTE4	780LTE4	800LTE4

Heat Recovery	ARUB
---------------	------

## 1.3 HR Unit

Power Supply	2 branches	3 branches	4 branches
1Ø, 220 - 240V, 60Hz	PRHR021	PRHR031	PRHR041

## 2. External Appearance







### 2.1 Indoor Unit

<p><b>Ceiling Cassette- 1Way</b>                      ARNU07GTU*2                      ARNU09GTU*2                      ARNU12GTU*2</p> <p>ARNU18GTT*2                      ARNU24GTT*2</p> <p>* A:Basic, C:Plasma</p> 	<p><b>Ceiling Concealed Duct - High Static</b></p> <p>ARNU07GBHA2 ARNU36GBGA2                      ARNU09GBHA2 ARNU42GBGA2                      ARNU12GBHA2 ARNU48GBRA2                      ARNU15GBHA2 ARNU54GBRA2                      ARNU18GBHA2 ARNU76GB8A2                      ARNU24GBHA2 ARNU96GB8A2                      ARNU28GBGA2</p> 
<p><b>Ceiling Cassette- 4Way</b></p> <p>ARNU05GTR*2 ARNU24GTP*2                      ARNU07GTR*2 ARNU28GTP*2                      ARNU09GTR*2 ARNU36GTN*2                      ARNU12GTR*2 ARNU42GTM*2                      ARNU15GTQ*2 ARNU48GTM*2                      ARNU18GTQ*2</p> <p>* A:Basic, C:Plasma</p> 	<p><b>Wall mounted (Libero)</b></p> <p>ARNU07GSB*2 ARNU15GSB*2                      ARNU09GSB*2 ARNU18GSC*2                      ARNU12GSB*2 ARNU24GSC*2</p> <p>* A:Basic, L:Plasma</p> 
<p><b>Ceiling Concealed Duct - Low Static</b></p> <p>ARNU05GL1G2 ARNU15GL2G2                      ARNU07GL1G2 ARNU18GL2G2                      ARNU09GL1G2 ARNU21GL3G2                      ARNU12GL2G2 ARNU24GL3G2</p> 	<p><b>ART COOL Gallery</b></p> <p>ARNU07GSF*2                      ARNU09GSF*2                      ARNU12GSF*2</p> <p>* E:Red V:Silver                      G:Gold 1: Kiss (Photo changeable)</p> 
<p><b>Ceiling Concealed Duct – Built-in (Low Static)</b></p> <p>ARNU07GB3G2 ARNU15GB3G2                      ARNU09GB3G2 ARNU18GB4G2                      ARNU12GB3G2 ARNU24GB4G2</p> 	<p><b>Floor Standing With case</b></p> <p>ARNU07GCEA2 ARNU15GCEA2                      ARNU09GCEA2 ARNU18GCFA2                      ARNU12GCEA2 ARNU24GCFA2</p> 
<p><b>ART COOL Mirror</b></p> <p>ARNU07GSE*2 ARNU15GSE*2                      ARNU09GSE*2 ARNU18GS8*2                      ARNU12GSE*2 ARNU24GS8*2</p> <p>* R:Mirror, V:Silver</p> 	<p><b>Without case</b></p> <p>ARNU07GCEU2 ARNU15GCEU2                      ARNU09GCEU2 ARNU18GCFU2                      ARNU12GCEU2 ARNU24GCFU2</p> 
<p><b>Ceiling &amp; Floor</b></p> <p>ARNU09GVEA2                      ARNU12GVEA2</p> <p><b>Ceiling Suspended</b></p> <p>URNU18GVJA2 URNU36GVKA2                      URNU24GVJA2 URNU48GVLA2</p> 	<p><b>Console</b></p> <p>ARNU07GQAA2                      ARNU09GQAA2                      ARNU12GQAA2                      ARNU15GQAA2</p> 
<p><b>Ceiling Cassette -2Way</b></p> <p>ARNU18GTL*2                      ARNU24GTL*2</p> <p>* A:Basic, C:Plasma</p> 	<p><b>Fresh Air Intake Unit</b></p> <p>ARNU48GBRZ2                      ARNU76GB8Z2                      ARNU96GB8Z2</p> 

\* In matters of combination with Outdoor unit system, refer the PDB of that outdoor units.

## 2.2 Outdoor Unit

### 2.2.1 Heat Recovery

CHASSIS	Model Name	Model
UX2	ARUB080LTE4 ARUB100LTE4 ARUB120LTE4	
UX3	ARUB140LTE4 ARUB160LTE4 ARUB180LTE4 ARUB200LTE4	
UX2 UX2	ARUB220LTE4 ARUB240LTE4	
UX3 UX2	ARUB260LTE4 ARUB280LTE4 ARUB300LTE4 ARUB320LTE4	
UX3 UX3	ARUB360LTE4 ARUB380LTE4 ARUB340LTE4 ARUB400LTE4	
UX3 UX3 UX2	ARUB420LTE4 ARUB440LTE4 ARUB460LTE4 ARUB480LTE4 ARUB500LTE4 ARUB520LTE4	
UX3 UX3 UX3	ARUB540LTE4 ARUB560LTE4 ARUB580LTE4 ARUB600LTE4	
UX3 UX3 UX3 UX3	ARUB620LTE4 ARUB720LTE4 ARUB640LTE4 ARUB740LTE4 ARUB660LTE4 ARUB760LTE4 ARUB680LTE4 ARUB780LTE4 ARUB700LTE4 ARUB800LTE4	

## 3. Combination of Outdoor Units

### 3.1 Heat Recovery

Model Name	Number of Units	Module(HP)						
		8	10	12	14	16	18	20
ARUB080LTE4	1	1						
ARUB100LTE4	1		1					
ARUB120LTE4	1			1				
ARUB140LTE4	1				1			
ARUB160LTE4	1					1		
ARUB180LTE4	1						1	
ARUB200LTE4	1							1
ARUB220LTE4	2		1	1				
ARUB240LTE4	2			2				
ARUB260LTE4	2			1	1			
ARUB280LTE4	2			1		1		
ARUB300LTE4	2			1			1	
ARUB320LTE4	2			1				1
ARUB340LTE4	2				1			1
ARUB360LTE4	2					1		1
ARUB380LTE4	2						1	1
ARUB400LTE4	2							2
ARUB420LTE4	3		1		1		1	
ARUB440LTE4	3		1		1			1
ARUB460LTE4	3		1			1		1
ARUB480LTE4	3		1				1	1
ARUB500LTE4	3		1					2
ARUB520LTE4	3			1				2
ARUB540LTE4	3				1			2
ARUB560LTE4	3					1		2
ARUB580LTE4	3						1	2
ARUB600LTE4	3							3
ARUB620LTE4	4				2	1	1	
ARUB640LTE4	4				2		2	
ARUB660LTE4	4				1	1	2	
ARUB680LTE4	4				2			2
ARUB700LTE4	4				1	1		2
ARUB720LTE4	4				1		1	2
ARUB740LTE4	4					1	1	2
ARUB760LTE4	4						2	2
ARUB780LTE4	4						1	3
ARUB800LTE4	4							4

# 4. Nomenclature

## 4.1 Indoor Unit

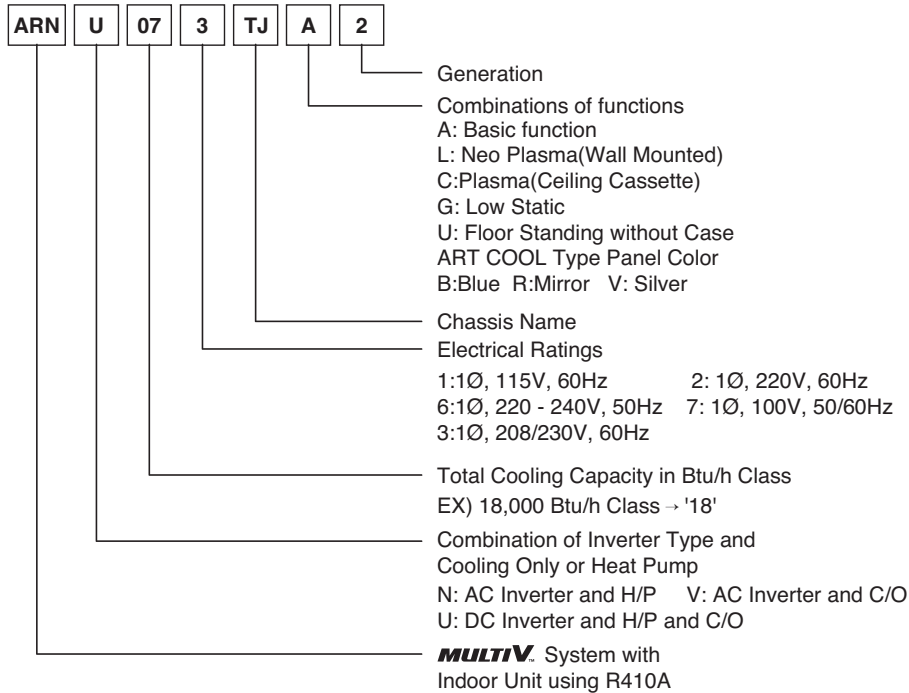

※ Heat recovery ventilator refer to the DX-Coil manual

## 4.2 Outdoor Unit

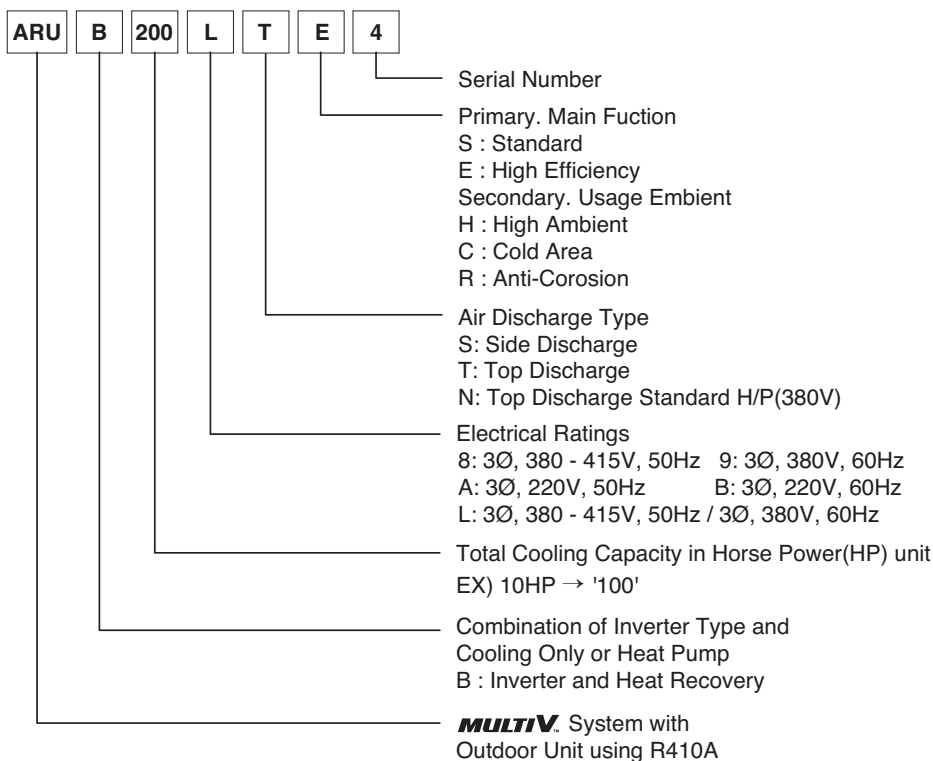

### 4.3 HR Unit

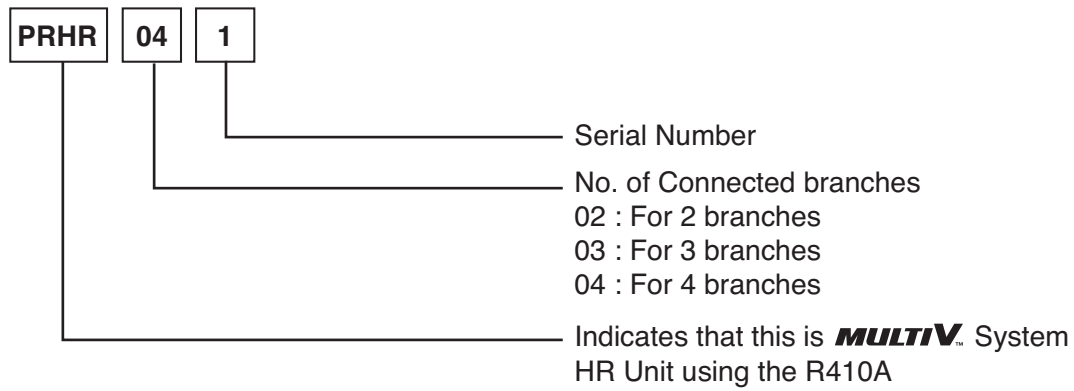

# Part 2

## Outdoor Units

# ARUB Series

- **Function .....18**

# Function

<b>1. Basic control .....</b>	<b>19</b>
1.1 Normal operation .....	19
1.2 Compressor control.....	19
1.3 Master and slave unit's EEV control .....	20
<b>2. Special control .....</b>	<b>21</b>
2.1 Oil return control .....	21
2.2 Defrost control.....	23
2.3 Partial Defrost .....	24
2.4 Stop operation.....	25
2.5 Oil equalizing control.....	25
<b>3. Protection control .....</b>	<b>26</b>
3.1 Pressure protection control .....	26
3.2 Discharge temperature control.....	27
3.3 Inverter protection control .....	27
3.4 Phase detection .....	28
3.5 Pressure switch.....	28
<b>4. Other control .....</b>	<b>29</b>
4.1 Initial setup.....	29
4.2 Emergency operation.....	32
4.3 Refrigerant Auto Charging .....	34
4.4 Pump Out.....	35
4.5 Refrigerant amount automatic judgment.....	36
4.6 ITR(Cooling).....	37
4.7 ITR(Heating) .....	38
4.8 FDD Code .....	40
4.9 Multi V ITR result report .....	41
4.10 Pump Down .....	42
4.11 Pump Out.....	43
4.12 Auto Back Up Function_Inverter compressor .....	45
4.13 Night Low Noise Function .....	46
4.14 Vacuum Mode .....	47
4.15 Static pressure compensation mode.....	47
4.16 Cool & Heat selector .....	48
4.17 Cycle Data View.....	49

## 1. Basic control

### 1.1 Normal operation

Actuator	Cooling operation	Heating operation	Stop state
Compressor	Fuzzy control	Fuzzy control	stop
Fan	Fuzzy control	Fuzzy control	stop
Main EEV	Upper : Min. pulse *Low : Full open	Fuzzy control	Min. pulse
Subcooling EEV	Fuzzy control	<ul style="list-style-type: none"> <li>• Normal : Vapor injection</li> <li>• Avoiding control of high discharge temperature</li> </ul>	Min. pulse
Indoor Unit EEV	Superheat fuzzy control	Subcooling fuzzy control	Min. pulse

**Note :** Heating operation is not functional at an outdoor air temperature of 27°C or more.

Cooling operation is not functional at an outdoor air temperature of 2°C or less with indoor unit combination of 10% or less

### 1.2 Compressor control

Fuzzy control : Maintain evaporating temperature( $T_e$ ) to be constant on cooling mode and condensing temperature( $T_c$ ) on heating mode by Fuzzy control to ensure the stable system performance.

( $T_c$ :47 ~51°C,  $T_e$ :2 ~ 5°C)

(1) Cooling mode

$T_e$  can be set various step at installation mode.

(2) Heating mode

$T_c$  can be set various step at installation mode.

**Note:** By setting dip switch,  $T_e$  and  $T_c$  are decided simultaneously.

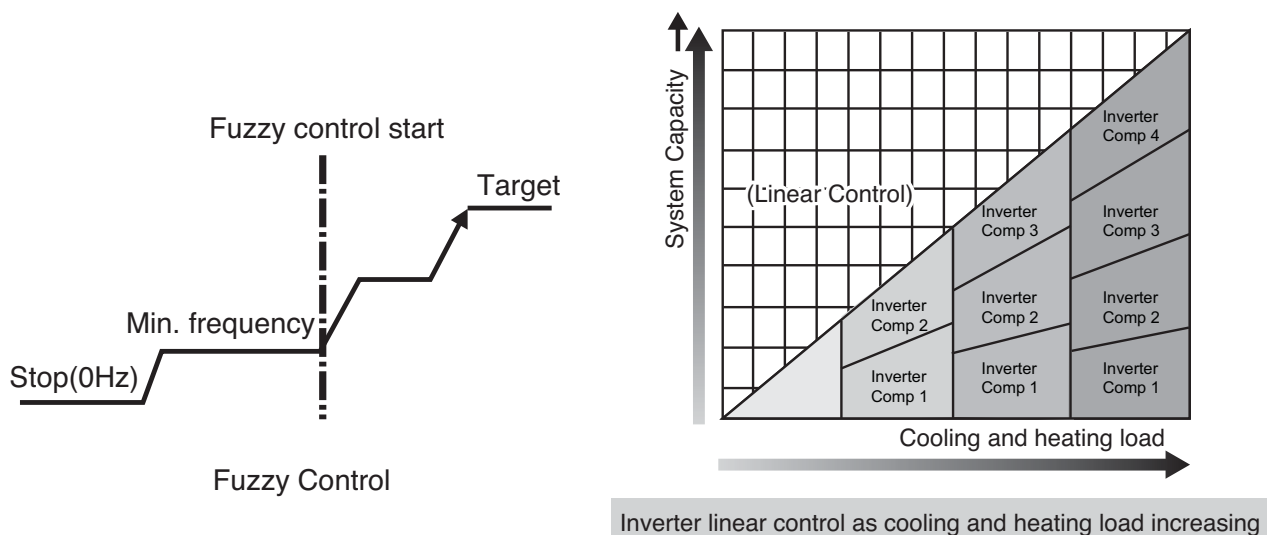

### 1.3 Master and slave Unit's EEV control

(1) Main EEV control

Main EEV operates with fuzzy control rules to keep the degree of super Heat(Superheat) (about 3°C) at the evaporator outlet stable during heating mode

The degree of Superheat =  $T_{\text{suction}} - T_{\text{evaporation}}$

$T_{\text{suction}}$  : temperature at suction pipe sensor(°C)

$T_{\text{evaporation}}$  : evaporation temperature equivalent to low pressure(°C)

(2) Subcooling EEV control(about 15°C)

Subcooling EEV works with fuzzy rules to keep the degree of Subcool at the outlet of subcooler during cooling mode

The degree of Subcool =  $T_{\text{condensation}} - T_{\text{liquid}}$

$T_{\text{liquid}}$  : temperature at outlet of subcooler(°C)

$T_{\text{condensation}}$  : condensation temperature equivalent to high pressure(°C)

(3) Avoiding excessive high discharge temperature : when main EEV opens some given opening (R410A : 800 pls) and discharge temperature is above 85°C in heating operation, subcooling EEV may control the "subcooling out temperature-evaporating temperature" to be some given difference.

(4) Vapor injection flow-rate control at heating mode

The degree of Superheat (VI\_SH) = Subcooler out(°C) – Subcooler in(°C)

-  $T_d \leq 80^\circ\text{C}$  : VI\_SH = 3°C

-  $80^\circ\text{C} < T_d \leq 90^\circ\text{C}$  : VI\_SH =  $-2 \cdot T_d / 10 + 19$

-  $90^\circ\text{C} < T_d$  : VI\_SH = 1°C

## 2. Special control

### 2.1 Oil return control

#### 2.1.1 Oil return control on cooling mode

Oil return operation recovers Oil level in compressor by collecting oil accumulated in pipe. Each cycle component operates as shown on the below table during oil return operation.

#### Outdoor Unit

Component	Starting	Running	Ending
Inv Compressor	30Hz	Setting Value	30Hz
FAN	Normal control	Normal control	Normal control
Main EEV	Upper : Min. pulse Low : Max. pulse	Upper : Min. pulse Low : Max. pulse	Upper : Normal control Low : Normal control
Subcooling EEV	Min. pulse	20 pulse	80 pulse
4way valve	OFF	OFF	OFF

#### Indoor Unit

Component	Starting	Running	Ending
Fan	Normal control	OFF	Normal control
Thermo on unit EEV	Normal control	Normal control	Normal control
Thermo off unit EEV	40 pulse	400 pulse	40 pulse
Oil return signal	OFF	ON	OFF

- Oil return operation time : 3 min for running step
- Starting condition : When low oil level which is measured by oil level sensor is kept continuously then oil return operation will be start.
- Oil return process ends if compressor protection control starts

## 2.1.2 Oil return control on heating mode

### Outdoor Unit

Component	Starting	Running	Ending
Inv Compressor	30Hz	Setting Value	40Hz
FAN	Normal control	Normal control	Normal control
Main EEV	Upper : Min. pulse Low : Max. pulse	Upper : Min. pulse Low : Max. pulse	Upper : Normal control Low : Normal control
Subcooling EEV	Min. pulse	20 pulse	80 pulse
4way valve	ON	OFF	ON

### Indoor Unit

Component	Starting	Running	Ending
Fan	Normal control	OFF	Normal control
Thermo on unit EEV	Normal control	400~800 pulse	Normal control
Thermo off unit EEV	80~130 pulse	400~800 pulse	80~130 pulse

- Oil return operation time : 3 min for running step
- Starting condition:same as cooling mode
- Oil return process ends if compressor protection control starts

## 2.2 Defrost

Defrost operation eliminates ice accumulated on heat exchanger, recovering performance of heat exchanger. Each cycle component operates as following table during defrost operation.

### Outdoor Unit

Component	Starting	Running	Ending
Inv Compressor	30Hz	Setting Value	40Hz
FAN	Stop	High pressure control	Normal control
Main EEV	Normal control	Max. pulse	Normal control
Subcooling EEV	Normal control	Min. pulse	Normal control
4way valve	On → OFF	OFF	ON

### Indoor Unit

Component	Starting	Running	Ending
Fan	OFF	OFF	OFF
Thermo on unit EEV	Normal control	400~800 pulse	Normal control

#### ■ Ending condition

- 1) All heat exchanger pipe temperature are above setting temperature for 30 sec.
- 2) The running time of defrost operation is over 30% of the total heating time
- 3) If compressor protection control starts by high discharge temperature of compressor etc.

## 2.3 Partial Defrost (ARUB\*\*\*LTE4 ONLY)

Partial defrost operation divides heat exchanger with upper and parts that gives a chance to make the defrost separately in order to proceed the heating performance continuously. Each cycle component operates as following table during partial defrost operation.

### Outdoor Unit

Component	Starting	Running	Ending
Inv Compressor	Normal control	Setting Value	Normal control
FAN	Normal control	Low pressure control	Normal control
Main EEV	Normal control	Normal control	Normal control
Subcooling EEV	Normal control	Normal control	Normal control
4way valve	ON	ON	ON

### Indoor Unit

Component	Starting	Running	Ending
Fan	ON(Setting)	ON(Low)	ON(Setting)
Thermo on unit EEV	Normal control	Normal control	Normal control

#### ■ Ending condition

- 1) Upper defrost ending condition over setting temperature.
- 2) Low defrost ending condition over setting temperature.
- 3) Max. 12 minutes

## 2.4 Stopping operation

### 2.4.1 Stopping operation on cooling mode

Component	Operation	Note
Inv Compressor	OFF	-
FAN	Stop	-
Main EEV	32 pulse	-
Subcooling EEV	16 pulse	Stop(Min. pulse)
4way valve	OFF	-

### 2.4.2 Stopping operation on heating mode

Component	Operation	Note
Inv Compressor	OFF	-
FAN	Stop	-
Main EEV	32 pulse	-
Subcooling EEV	16 pulse	Stop(Min. pulse)
4way valve	ON	OFF over 30°C air temperature

## 2.5 Oil equalizing control

This function prevent oil unbalance between inverter. compressor.

When oil level which is measured by oil level sensor is kept differently between each compressor then oil equalizing EEV will be open during 5 minutes.

### 3. Protection control

#### 3.1 Pressure protection control

##### 3.1.1 Pressure control on cooling mode

###### ■ High pressure control

Pressure Range	Compressor	Fan
$P_d \geq 4000$ kPa 3775 kPa 3578 kPa	Stop	Stop
$P_d > 3775$ kPa	-15Hz/10sec.	+100RPM/10sec.
$P_d \geq 3513$ kPa	Frequency holding	+100RPM/10sec.
$P_d \geq 3480$ kPa	+2 Hz or less/10sec.	+100RPM/10sec.
$P_d < 3480$ kPa	Normal control	

###### ■ Low pressure control

Pressure Range	Compressor	Fan
$P_s \leq 98$ kPa, 1 minute later operation	Stop	Stop
$P_s \leq 124$ kPa, 1 minute before operation	-15Hz/10sec.	-100RPM/ 10sec.

\* Frequency holding : frequency ( or RPM ) is not increasing ( can decrease )

##### 3.1.2 Pressure control on heating mode

###### ■ High pressure control

Pressure Range	Compressor	Fan
$P_d \geq 4003$ kPa	Stop	Stop
$P_d > 3415$ kPa	-15Hz/10sec.	-50RPM/10sec.

###### ■ Low pressure control

Pressure Range	Compressor	Fan
$P_s \leq 98$ kPa	Stop	Stop
$P_s \leq 124$ kPa	-15Hz/10sec.	+100RPM/10s
$P_s \leq 137$ kPa	Frequency holding	+100RPM/10s
$P_s \leq 190$ kPa	+2 Hz or less/10sec.	+100RPM/10s
$P_s \geq 190$ kPa	Normal control	Normal control

\* Frequency holding : frequency ( or RPM ) is not increasing ( can decrease ).

## 3.2 Discharge temperature control

### ■ Outdoor unit control

Temperature range	Compressor	Sub cooling EEV	IDU EEV
$T_{dis} > 110^{\circ}\text{C}$	OFF	SC,SH decrease control	SH decrease control
$T_{dis} > 108^{\circ}\text{C}$	-5Hz/10sec.	SC,SH decrease control	SH decrease control
$T_{dis} \geq 105^{\circ}\text{C}$	Frequency holding	SC,SH decrease control	SH decrease control
$T_{dis} \leq 100^{\circ}\text{C}$	Normal control	SC,SH decrease control	SH decrease control
$T_{dis} > 100^{\circ}\text{C}$	Normal control	SC,SH decrease control	SH decrease control

SC : Sub Cooling, SH : Super Heating

## 3.3 Inverter protection control

### Cooling mode

	Normal Operation		Frequency Down		System Stop	
	4.8HP	6.8HP	4.8HP	6.8HP	4.8HP	6.8HP
AC Input Current	19A or less	28A or less	19A or more	28A or more	24A or more	32A or more
Compressor Current	24A or less	35A or less	24A or more	35A or more	30A or more	41A or more

### Heating mode

	Normal Operation		Frequency Down		System Stop	
	4.8HP	6.8HP	4.8HP	6.8HP	4.8HP	6.8HP
AC Input Current	19A or less	28A or less	19A or more	28A or more	24A or more	32A or more
Compressor Current	24A or less	35A or less	24A or more	35A or more	30A or more	41A or more

※ AC input current is input current of inverter compressor except constant current (current pass through noise filter)

### 3.4 Phase detection

- If the power lines are connected incorrectly the product will not work and displays error like below.
  - Case1) 1 or more phase lines are missing (disconnected)
  - Case 2) Neutral (N) line connected wrongly to any phase line

Case	Terminal block				Error No.
	R	S	T	N	
Missed Phase	X				50
		X			
			X		5
				X	25
Reversed Phase	N				50
		N			
			N		5
				N	No error

※ In the case of series unit if the error occurs more than a single unit at same time then only a small unit number will be displayed.

Example) Master and Slave2 occur error no. 50, '501' display on the 7segment.

\* Master: \*\*\*1, Slave1:\*\*\*2, Slave2:\*\*\*3, Slave3:\*\*\*4

### 3.5 Pressure switch

- Main has pressure sensing switch in series between compressor and power relay.
- The state of pressure sensing switch is normally on. It has small electric current from 220V AC. Never touch the connecting terminal with hand nor short two wires directly.

## 4. Other control

### 4.1 Initial setup

There are 4 initial setup steps before running.  
All DIP switch setting must be completed before initial setup.

- 1) Step 1 : factory setting value display  
Factory setting value is displayed in 7 segment on PCB for 24sec.  
All dip switches must be set properly before step 1.

Power is on	
Master model code is displayed (3sec)	18
Slave1 model code is displayed (3sec)	16
Slave2 model code is displayed (3sec)	14
'Slave3 model code is displayed(3sec)'	14
Total capacity including sub units is displayed (2sec)	62
Heat Recovery : Display 2 is default value	3
Power type	38
Model type	1

## Function

### 2) Step 2 : Communication check

- If all model code is displayed in 7 segment including all Slave unit, communication between outdoor units is normal.
- If 104\* is displayed in 7-segment, check communication wires between outdoor units and Dip switch setting.

### 3) Step 3 : PCB error check

- After 40 sec, error check begins.

#### ■ Master/ Slave unit

- All errors of units including Slave units are displayed in 7 segment.
- If communication between main PCB and inverter PCB isn't normal, 52\* is displayed in 7-segment
- If communication between main PCB and fan PCB isn't normal, 105\* is displayed in 7-segment.
- If error is displayed, check corresponding wires.

### 4) Step 4 : Auto addressing of indoor units

- Auto addressing begins when address(red) button in Main PCB is pressed for 6 sec.
- During auto addressing, 7 segment on main PCB displays "88"
- After auto addressing, the number of indoor units is displayed in 7 segment for 30 sec. The address of each indoor unit is displayed on each wired remote controller.

#### ■ Heat Recovery (Main PCB)

Push address(red) button for 3 sec.

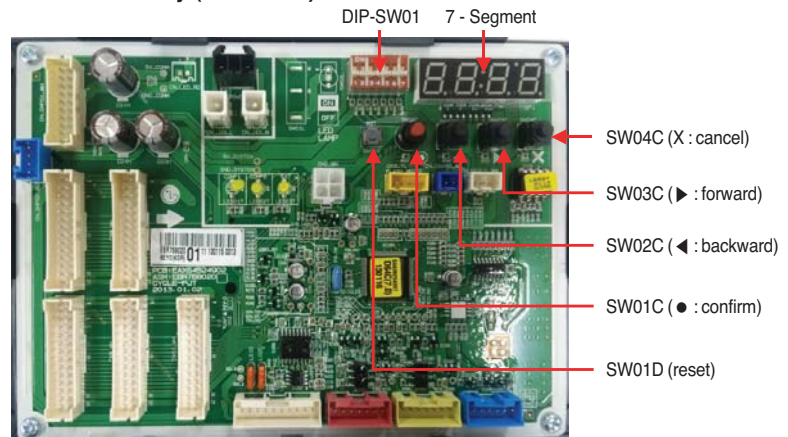

Auto address starts



Auto address is in progress (max. 15 min.)



The number of indoor units is displayed for 30 sec.



(35 indoor units found)

Auto address process is finished.  
Every indoor unit displays its address on wired remote controller and the 7 segment of main PCB is off.



## ■ Setting the function

Select the mode/function/option/value using '▶', '◀' Button and confirm that using the '●' button after dip switch No.5 is turned on.

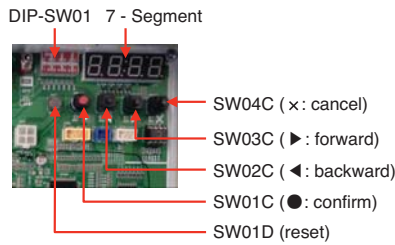
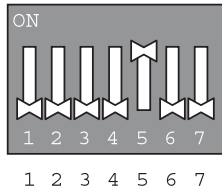

MODE		FUNCTION		OPTION		VALUE		ACTION		remarks	
content	Display1	content	Display2	content	Display3	content	Display4	implement	Display5		
FDD	Fdd	Refrigerant auto charging(cooling)	F <sub>n1</sub>	-	-	-	-	Operate	show the process	-	
		Refrigerant auto charging(heating)	F <sub>n2</sub>	-	-	-	-	Operate	show the process	-	
		Refrigerant amount auto judgment(cooling)	F <sub>n3</sub>	-	-	-	-	Operate	show the process	-	
		Refrigerant amount auto judgment(heating)	F <sub>n4</sub>	-	-	-	-	Operate	show the process	-	
		ITR(Cooling)	F <sub>n5</sub>	-	-	-	-	Operate	show the process	-	
		ITR(Heating)	F <sub>nb</sub>	-	-	-	-	Operate	show the process	-	
Installation	Func	Cool & Heat Selector	F <sub>n1</sub>	oFF	op1~op2	selected the option	-	change the set value	blank	save in EEPROM	
		Static pressure compensation	F <sub>n2</sub>	oFF	op1~op3	selected the option	-	change the set value	blank	save in EEPROM	
		Night low noise	F <sub>n3</sub>	oFF	op1~op12	selected the option	-	change the set value	blank	save in EEPROM	
		Overall defrost	F <sub>n4</sub>	on	oFF	selected the option	-	change the set value	blank	save in EEPROM	
		ODU address	F <sub>n5</sub>	-	-	-	0~255	set the value	change the set value	blank	save in EEPROM
		Snow removal & rapid defrost	F <sub>nb</sub>	oFF	op1~op3	selected the option	-	change the set value	blank	save in EEPROM	
		IDU capacity adjusting	F <sub>n7</sub>	-	op1~op2	selected the option	-	change the set value	blank	save in EEPROM	
		Target pressure adjusting	F <sub>n8</sub>	-	op1~op4	selected the option	-	change the set value	blank	save in EEPROM	
SVC	S <sub>uc</sub>	Pump Down	SE1	-	-	-	-	start operation	P <sub>d</sub>	-	
		Pump Out	SE2	-	-	-	-	start operation	P <sub>o</sub>	-	
		Vacuum mode	SE3	-	-	-	-	start operation	u <sub>Rcc</sub>	-	
		Backup	SE4	unit	inv1~inv2	selected the option	-	start operation	on oFF	save in EEPROM	
		Forced oil return	SE5	-	-	-	-	start operation	o1	-	
		Forced defrost	SEb	-	-	-	-	start operation	dEF	-	
		Cycle data view	SE7	-	op1~op7	-	-	Show in segment	Show the each numerical value in process	-	

\* Functions save in EEPROM will be kept continuously, though the system power was reset.

## 4.2 Emergency operation

- If a compressor is out of order, the system can be run except the defective compressor by backup function.

■ Automatic emergency operation(automatic back up function)

If outdoor unit detect comp defect during operation,, automatic back up mode is set.

- 1) Inverter 1 compressor automatic emergency operation.
- 2) Inverter 2 compressor automatic emergency operation.

■ Manual emergency operation(Manual back up function)

- 1) Check which compressor is broken. (refer to “Trouble Shooting Guide”)
- 2) Turn off the power.
- 3) Set the dip S/W of defective outdoor unit.
- 4) Turn on the power.

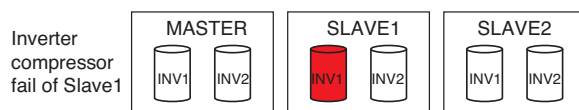

SLAVE1 unit PCB DIP switch on : No.5

Select the mode using '▶', '◀' Button : “SVC”  
Push the '●' button

Select the Function using '▶', '◀' Button : : “Se4”  
Push the '●' button

Select the Option using '▶', '◀' Button : : “inv1”  
Push the '●' button

Select the Action using '▶', '◀' Button : : “on”  
Push the '●' button

Backup mode cancellation method

Select the Action using '▶', '◀' Button : : “off”  
Push the '●' button

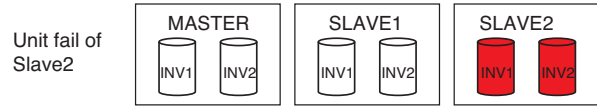

SLAVE2 unit PCB DIP switch on : No.5

Select the mode using '▶', '◀' Button : “SVC”  
Push the '●' button

Select the Function using '▶', '◀' Button : : “Se4”  
Push the '●' button

Select the Option using '▶', '◀' Button : : “unit”  
Push the '●' button

Select the Action using '▶', '◀' Button : : “on”  
Push the '●' button

### CAUTION

**Emergency operation with inverter compressor failure should not last 48 hours. → It causes other compressor failure.**

**During the emergency operation, cooling/heating capacity may be lower.**

### FDD Check list

\* Please check the following.

1. Automatic address setting has been preceded by a test drive will proceed on the premise.  
After installation, auto address must be checked because it is related the number of installation
2. 3 minutes after the initial power on test drive at one point.  
Aafter the power on, MICOM data reset and communication with indoor unit time is 3minute
3. Indoor unit must be 7 series over
4. In FDD test drive, state of the test drive and error are displayed using 7 segment.  
The process of the test drive and state of error are displayed using only the master outdoor uint.
5. If the error is occurred during the test drive, it will be operated the last step after turn off the test drive.  
Ater the dip switch off, pressing the black button for 2 seconds in order to reset all data and return to operation standby state
6. SW04C (X: Cancel) button and SW01C (●: execute) button is pressed for more than 5 seconds at the same time when the test drive must be turned of the reason of abrupt trouble during test drive.
7. All indoor units are turned off or the results are displayed after 90 seconds when the test drive is over.
8. First, please pressing the main PCB reset button for 3 minutes when you want to use all FDD functions.
9. Normal test run is operated when you use more than LGMV 7.0.3 version.

### 4.3 Refrigerant Auto Charging

This function charge suitable refrigerant amount in system through cycle operation automatically.

If the refrigerant amount is inaccurate by service, pipe leakage, etc, can use this function.

Use refrigerant charging, if service only.

Put the refrigerant by calculating the refrigerant amount surely, if install.

Refrigerant charging time can be different following the charging refrigerant amount.

( Charging time : about 3 minute/kg )

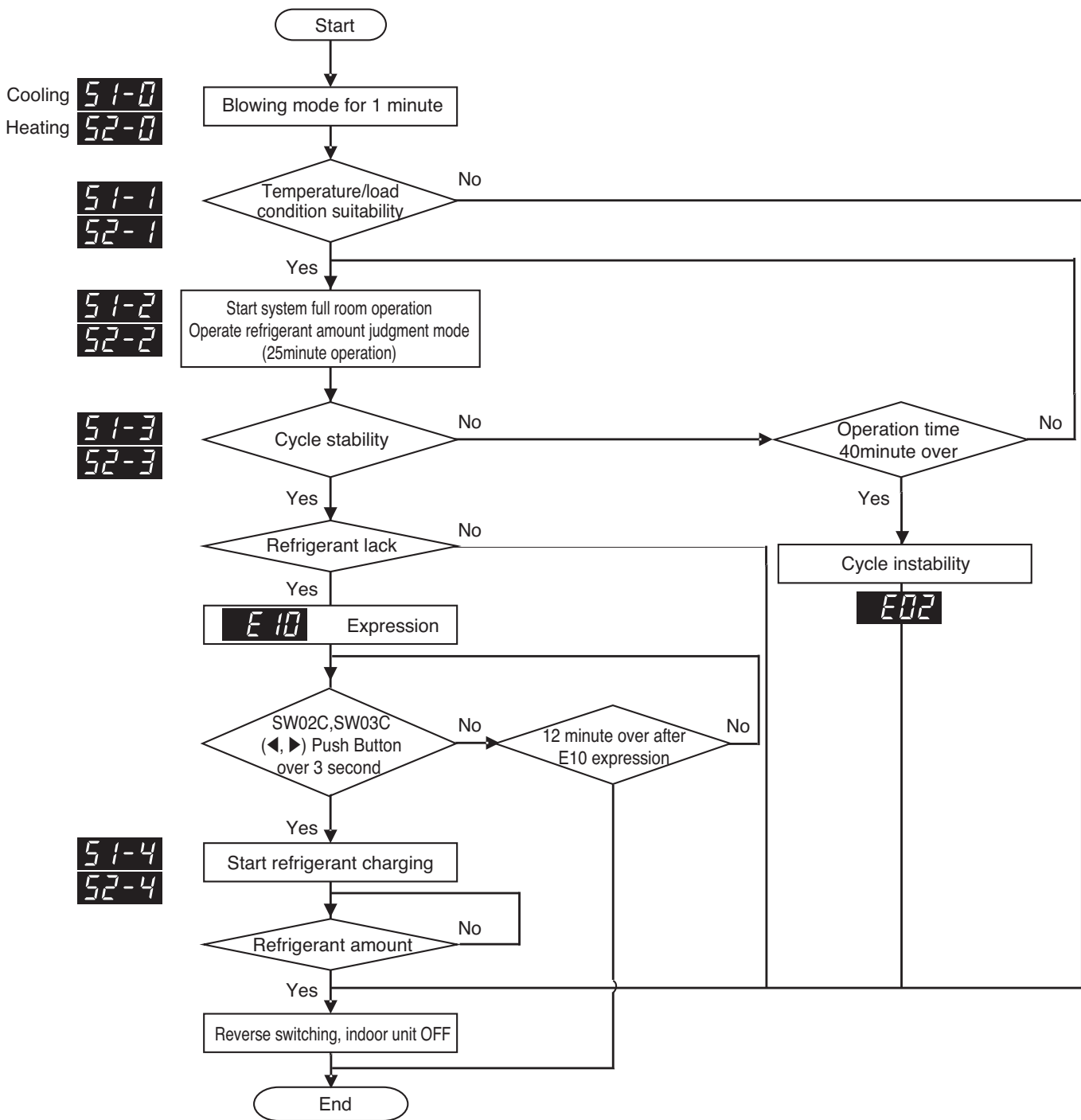

- Install refrigerant charging device like this page.
- If it is out of the guarantee temperature range, can end by not operating refrigerant charging.
  - Outdoor guarantee temperature range (cooling : 0~43°C, heating : -10~24°C)
  - Indoor guarantee temperature range (cooling : 18~32°C, heating : 10~27°C)
- If the system are turned off continuously by low pressure decrease excessively due to refrigerant lack before E10 expression, try again after add about 15% refrigerant of regular refrigerant amount.
- Press SW04C(X: Cancel) button and down dip switch after function end.

#### 4.4 Refrigerant charging method and error contents

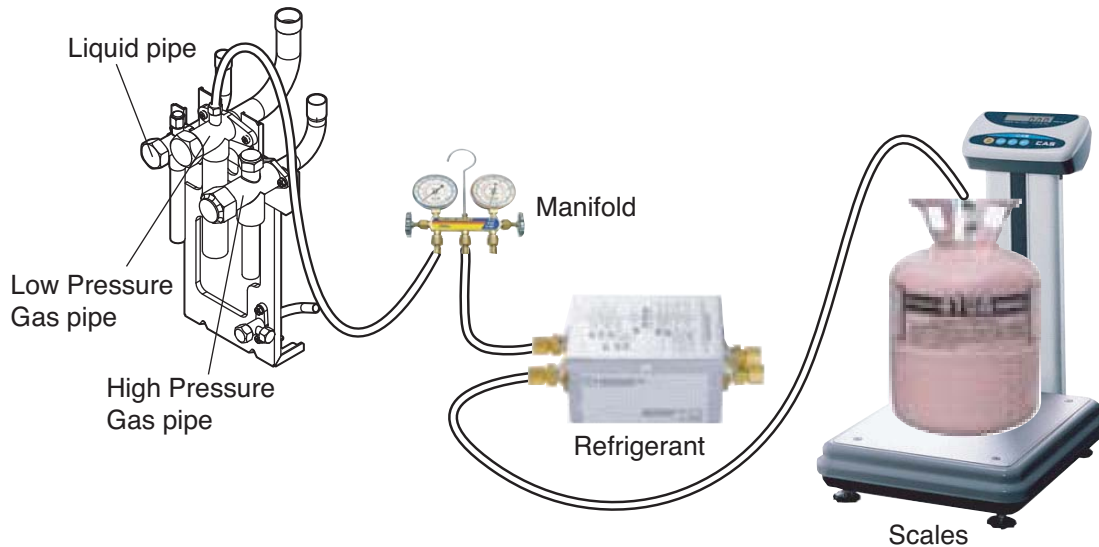

##### < ORDER >

1. Prepare Manifold, refrigerant and scale. (sold separately)
2. Connect Manifold to refrigerant charging port As shown in the figure above.
3. Connect Manifold and refrigerant.
4. Perform the air purge between Manifold hose.
5. When **E 10** is displayed, open the valve and fill the system with the refrigerant.

### **!** WARNING

- When perform the leakage test and air purge, please use a vacuum pump or an inert gas. (nitrogen)  
If you use Oxygen, compressed air and flammable gas, there are fire and danger of explosion.  
There are risk of death, personal injury, fire, explosion.

### **!** CAUTION

1. When you put refrigerant, using the specified equipment.
2. Please the wired remote control to set the main unit.
3. During Indoor unit operating, be careful not to be Thermo off.
4. If The Outdoor unit occurred frost when Heating automatic refrigerant filling,  
Please restart corresponding function after forced defrost.

### 4.5 Refrigerant amount automatic judgment

Ability to judge the system's refrigerant automatically through the system operation.

Function to Judge the refrigerant shortage and excess and can be used with refrigerant auto charging function.

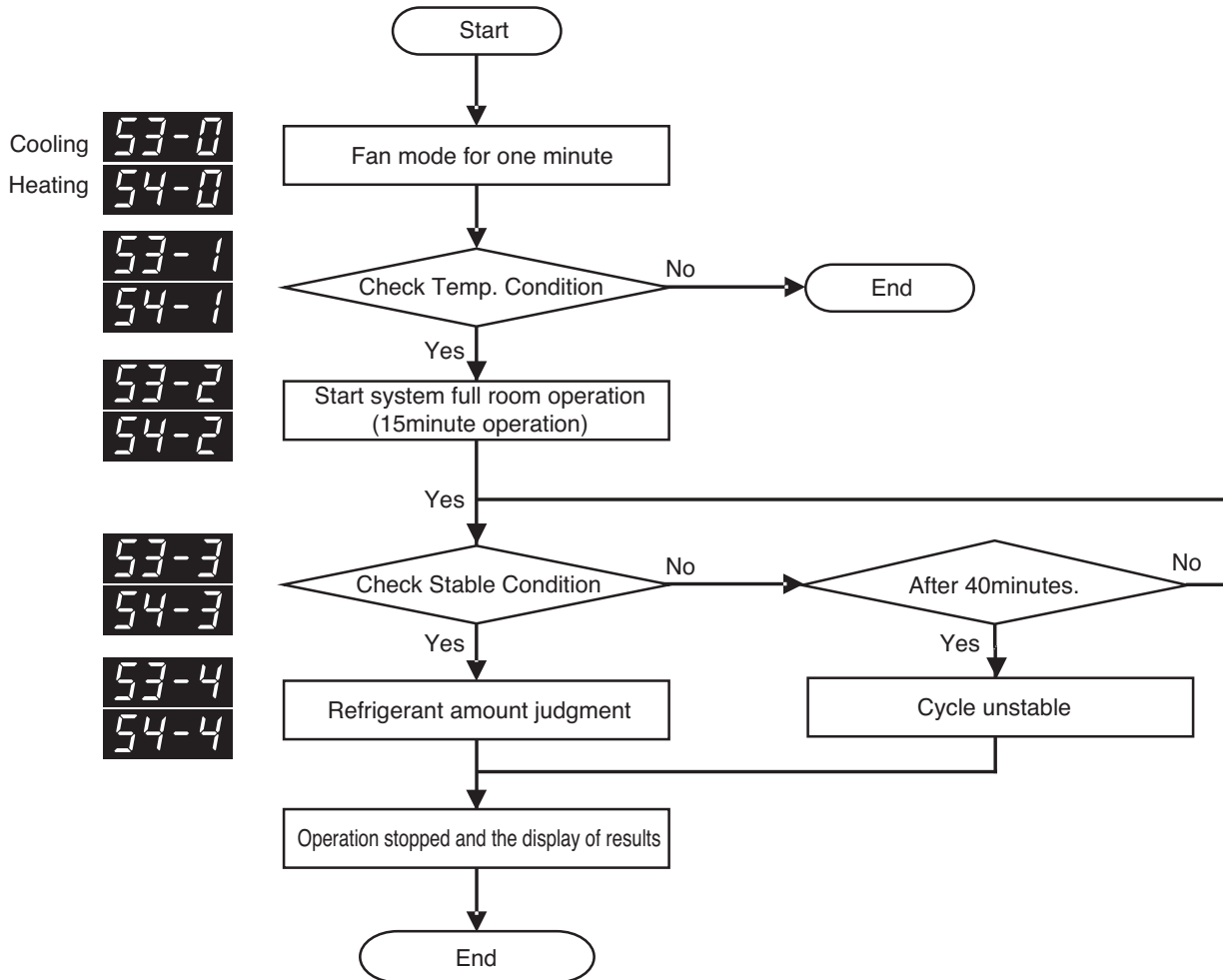

• The numeral on 7-segment is the result value of the amount of refrigerant which is the degree of hyperactivity or lack of the percentage value about current amount of refrigerant per the total amount of refrigerant.

- ex1) 20 → 20% refrigerant hyperactivity → need to remove
- ex2) -20 → 20% lack refrigerant → need to charge
- ex3) 00 → Don't need to adjustment

- If it is out of the Indoor units load and outdoor guarantee temperature range, can end Refrigerant amount automatic judgment.
  - Indoor unit load range : 80~130%
  - Outdoor warranty temperature range(cooling: 0~43°C, heating:-10~24°C)
- although 15minutes have not elapsed during full room operation indoor unit, amount of refrigerant is judged directly in special case.
- Press SW04C(X: Cancel) button and down dip switch after function end.

### 4.6 ITR(Cooling)

This function is checking process for normal operation of parts and system On operating system.

- Saved data can check using LGMV.

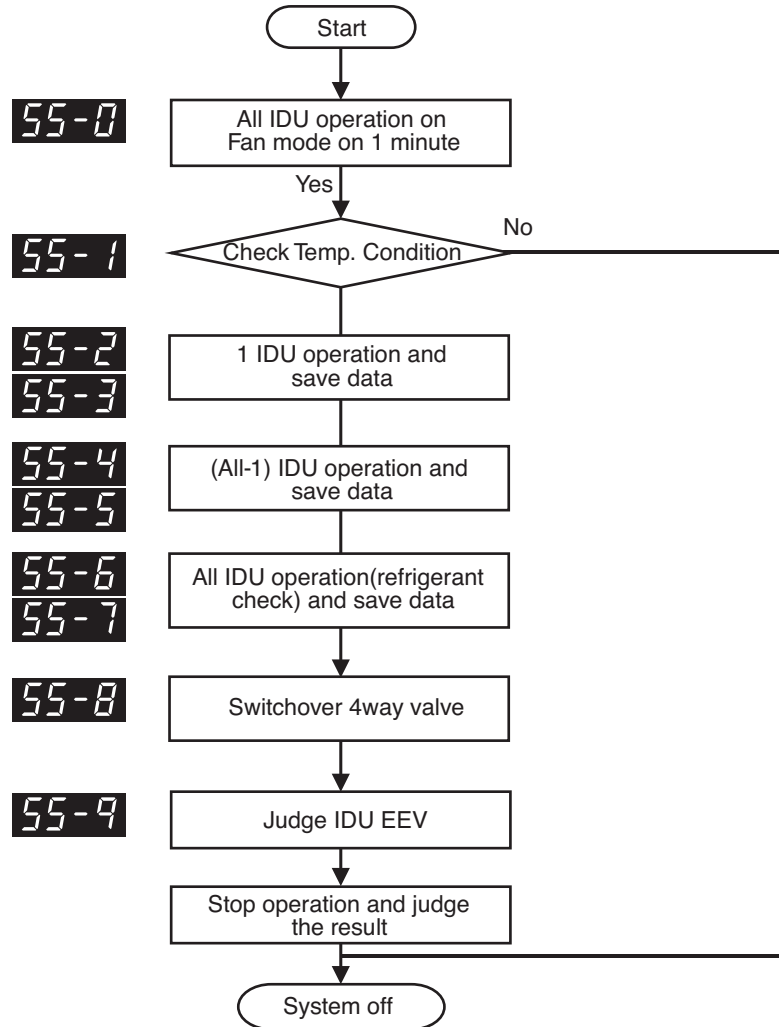

		Judgment	Code	Display
ITR(Cooling)	IDU EEV	OK	5-Cn	5-cn
		NG	5-C1	5-c1
		Impossible to Judge	5-CF	5-cF
	Refrigerant	More than standard	ex) 20%	20
		Less than standard	ex) -15%	-15
		Don't Adjustment required	00	00
		Impossible to Judge	3-CF	3-cF

## Function

Guaranteed Temperature range(Error occurs out of guaranteed temperature range)

IDU : 18 ~ 32 °C

ODU : 0~ 43 °C

In case the function is not used, set the dip S/W OFF and reset the power.

**NOTE** : If occur the indoor unit error, that indoor unit operate in fan mode.

But don't display the indoor unit number that occurred an error.

## 4.7 ITR(Heating)

This function is checking process for normal operation of parts and system On operating system.

- Saved data can check using LGMV.

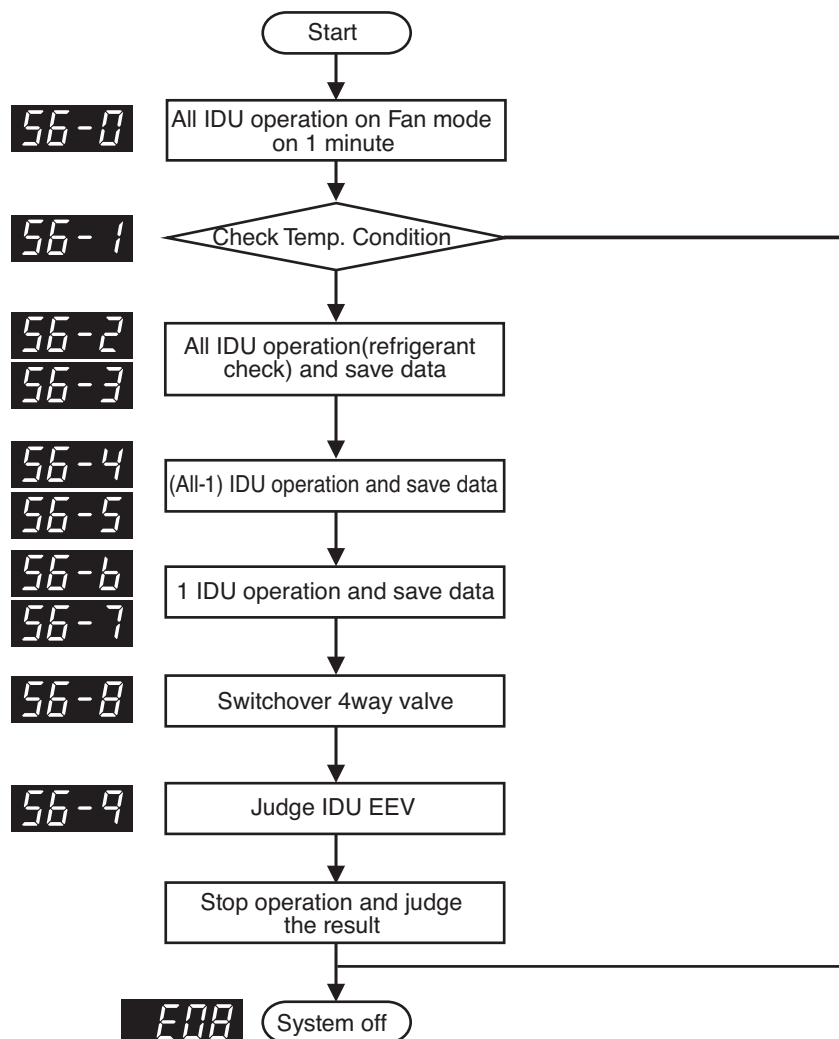

		Judgment	Code	Display
ITR(Heating)	IDU EEV	OK	6-Cn	<b>6-cn</b>
		NG	6-C1	<b>6-c1</b>
		Impossible to Judge	6-CF	<b>6-cF</b>
	Outdoor Main EEV	OK	7-Cn	<b>7-cn</b>
		NG	7-C1	<b>7-c1</b>
		Impossible to Judge	7-CF	<b>7-cF</b>
	Refrigerant	More than standard	ex) 20%	<b>20</b>
		Less than standard	ex) -15%	<b>-15</b>
		Don't Adjustment required	00	<b>00</b>
		Impossible to Judge	3-CF	<b>4-cF</b>











Guaranteed Temperature range(Error occurs out of guaranteed temperature range)

IDU : 18 ~ 32 °C

ODU : -10 ~ 24 °C

In case the function is not used, set the dip S/W OFF and reset the power.

## 4.8 FDD Code

Code	Display	Cause
E01		130% more than outdoor unit rated capacity or 80% less than outdoor unit rated capacity
E02		System Unstable Error
E03		Temperature Range Error
E04		Can't operate FDD function to be frost
E05		In case error occurs during sensor checking process
E06		Occurs when the indoor unit number is one.
E07		If not click the button in auto charging function.
E08		FDD feature forced termination. Or Refrigerant auto charging normal termination.
E09		Wait a system-off for operate FDD function.
E10		Need additional refrigerant sealed.
System error	Same as normal operation	Occur system error.

## 4.9 Multi V ITR result report

Follow the process.

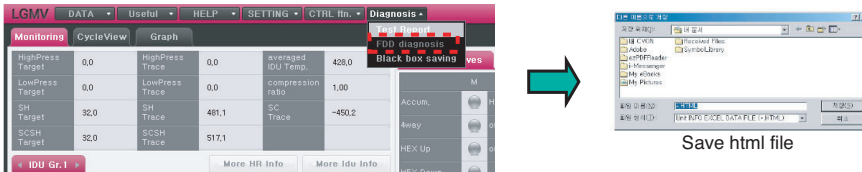

Multi V Start up Confirmation										
Date	Company Name & Address			Telephone			Name			
Person In Charge	Installer									
	Consultant									
	Supervisor									
Product		Model	Model	No.	Position					
	Outdoor Unit	0	0							
	Indoor Unit			0						
	HR Unit			0						
Test Run Results										
Operation Mode		OFF		All IDU Operation			1 IDU Operation		STEP	0
Check Items		Min.	Max.	Average	Min.	Max.	Average	OK/NG	Criterion For Judgment	
Temp. Condition	IDU Air Temp	-	-	0	-	-	-		20~30°C	
	ODU Air Temp	-	-	0	-	-	-			
Indoor Unit	IDU pipe inlet Temp	0	0	0	0	0	0			
	IDU pipe outlet temp	0	0	0	0	0	0			
	IDU LEV Openess	0	0	0	0	0	0			
Outdoor Unit	Pressure	High Pressure	0	0	0	0	0	0	3,600kPa ↓ (Cool) 2,300kPa ↓ (Heat)	
		Low Pressure	0	0	0	0	0	0	1,300kPa ↑ (Cool) 200kPa ↑ (Heat)	
	COMP	COMP Operate Combination		Inv : 0 Hz Comp : 0 EA ON			-	-	-	
		CT Value	ODU #1 Comp1	-	-	0	-	-	0	24A
			ODU #1 Comp2	-	-	0	-	-	0	
			ODU #2 Comp1	-	-	0	-	-	0	
			ODU #2 Comp2	-	-	0	-	-	0	
			ODU #3 Comp1	-	-	0	-	-	0	
			ODU #3 Comp2	-	-	0	-	-	0	
			ODU #4 Comp1	-	-	0	-	-	0	
			ODU #4 Comp2	-	-	0	-	-	0	
		Discharge Temp.	ODU #1 Comp1	-	-	300	-	-	300	50°C ~ 100°C
			ODU #1 Comp2	-	-	300	-	-	300	
			ODU #2 Comp1	-	-	300	-	-	300	
			ODU #2 Comp2	-	-	300	-	-	300	
			ODU #3 Comp1	-	-	300	-	-	300	
	ODU #3 Comp2		-	-	300	-	-	300		
	Main Voltage	R-phase	0	0	0	-	-	-	342~456 V	
		T-phase	-	-	-	-	-	-		
	Main Current	R-phase	0	0	0	-	-	-	20A ↓	
T-phase		-	-	-	-	-	-			
Discharge Superheat	ODU #1	-	-	0	-	-	0	10°C ~ 50°C(Heat)		
	ODU #2	-	-	0	-	-	0			
	ODU #3	-	-	0	-	-	0			
	ODU #4	-	-	0	-	-	0			
Suction Superheat	ODU #1	-	-	0	-	-	0	0.5°C (Cool) 0.5°C~7°C(Heat)		
	ODU #2	-	-	0	-	-	0			
	ODU #3	-	-	0	-	-	0			
	ODU #4	-	-	0	-	-	0			
ODU LEV Openness	ODU #1	0	0	0	0	0	0			
	ODU #2	0	0	0	0	0	0			
	ODU #3	0	0	0	0	0	0			
	ODU #4	0	0	0	0	0	0			
Refrigerant Check		0								
Main EEV Check		Unstable Condition								
IDU EEV Check		Unstable Condition								

## 4.10 Pump Down

This function gathers the refrigerant present in the system to ODU

Use this function to store refrigerant of system in ODU for leakage or IDU replacement.

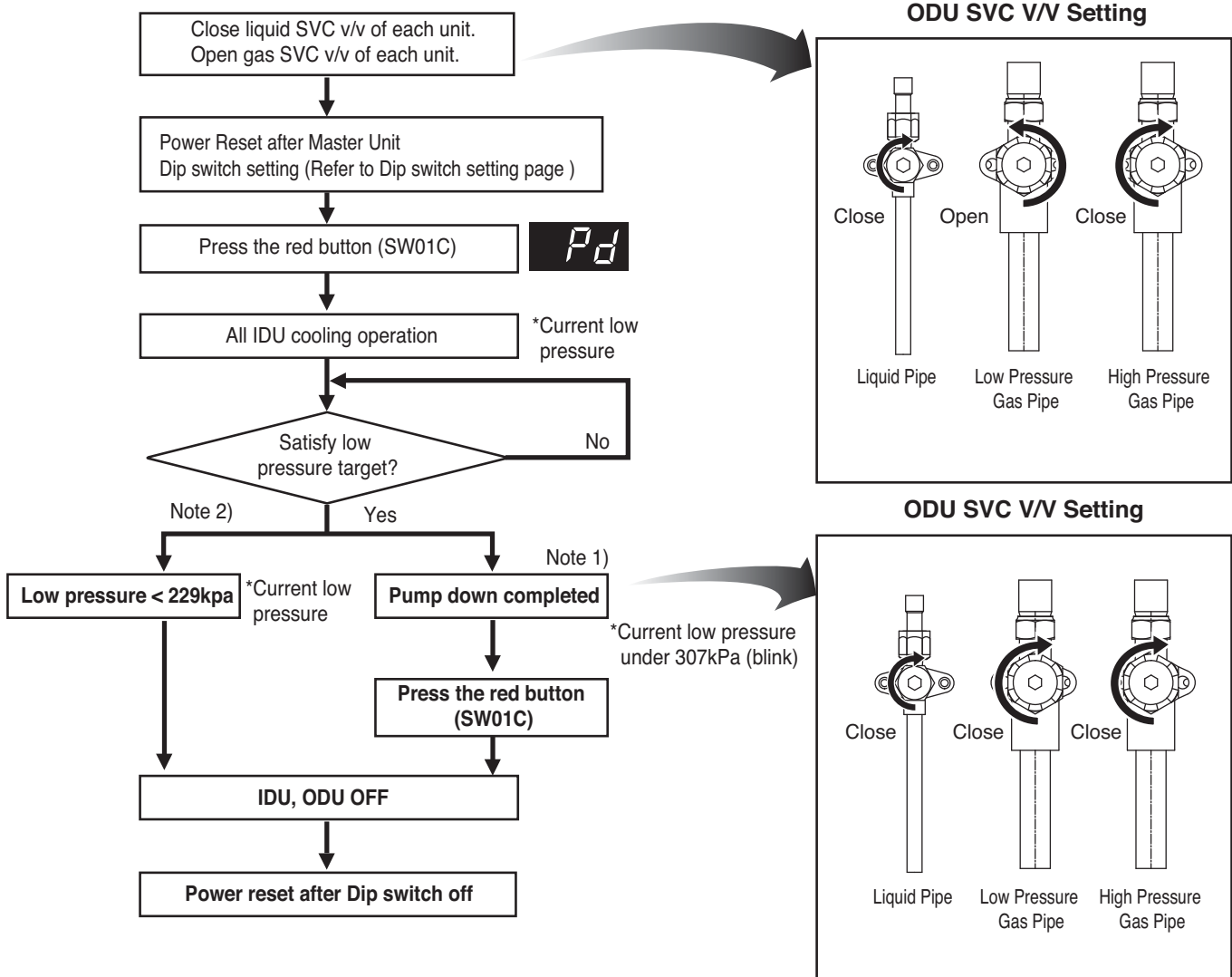

**[Note]**

If low pressure become under 307kPa (blink), close the gas SVC V/V of all ODU immediately.

If low pressure descends below 229 kPa, the system turns off automatically. Close the gas SVC V/V immediately.

**⚠ Caution**

1. Use pump down function within guaranteed temperature range  
 IDU : 20~32C  
 ODU : 5~40C
2. Make certain that IDU doesn't run with thermo off mode during operation
3. Maximum operation time of pump down function is 30 min.  
 (in case low pressure doesn't go down)

## 4.11 Pump Out

This function gathers the refrigerant to other ODU and IDU.

Use this function in case of compressor failure, ODU parts defect, leakage.

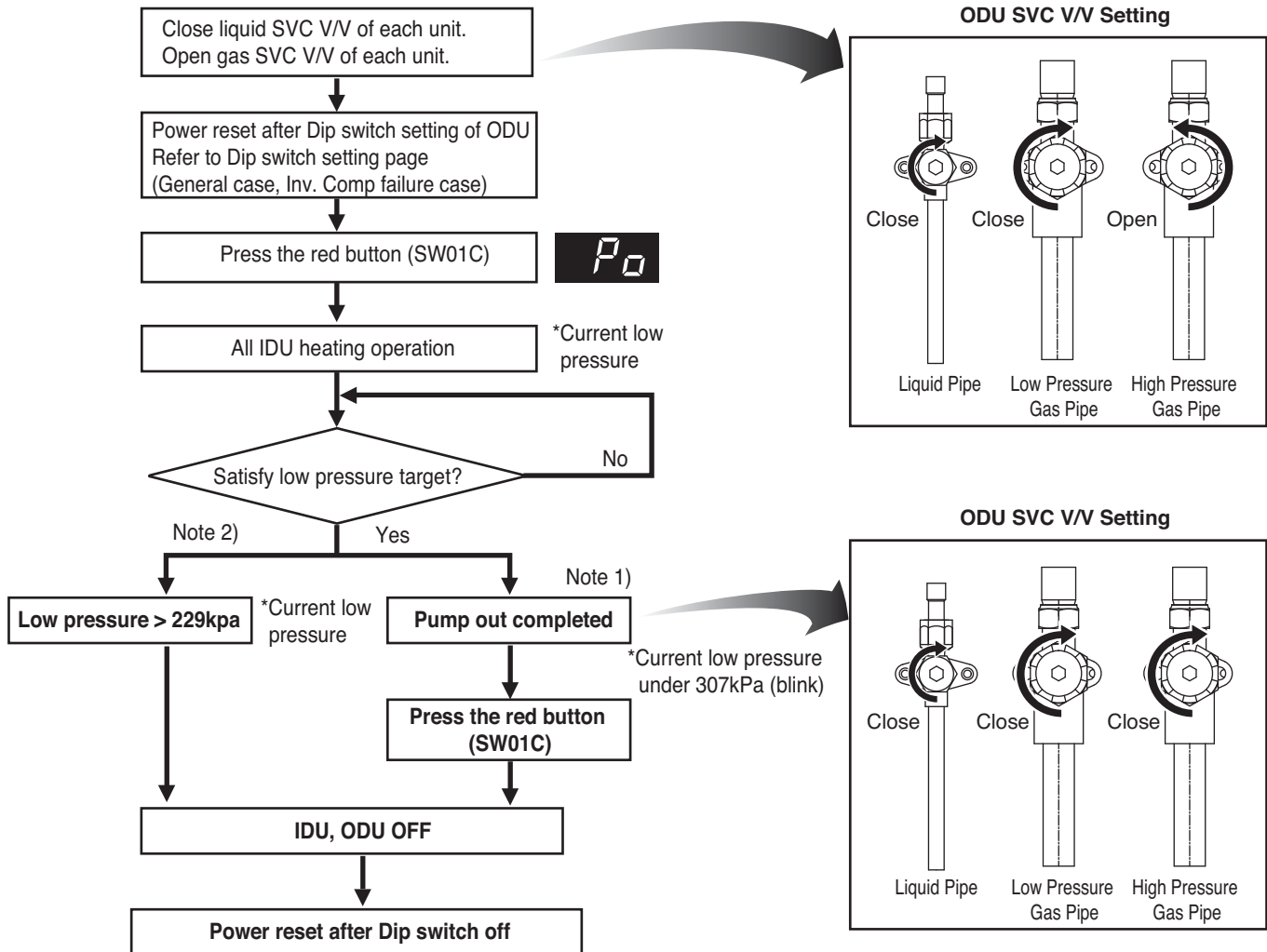

**[Note]**

If low pressure become under 307kPa (blink), close the gas SVC V/V of all ODU immediately.

If low pressure descends below 229 kPa, the system turns off automatically. Close gas SVC V/V immediately.

This function is operating only Heat Pump model.

**⚠ Caution**

1. Use pump out function within guaranteed temperature range  
 IDU : 10~30°C  
 ODU : 5~40°C
2. Make certain that IDU doesn't run with thermo off mode during operation
3. Pump out function takes 2~5 min. after compressor start.  
 Make certain that IDU doesn't run with thermo off mode during operation  
 (in case low pressure doesn't go down)

■ Example. Slave2 ODU Inv Comp failure

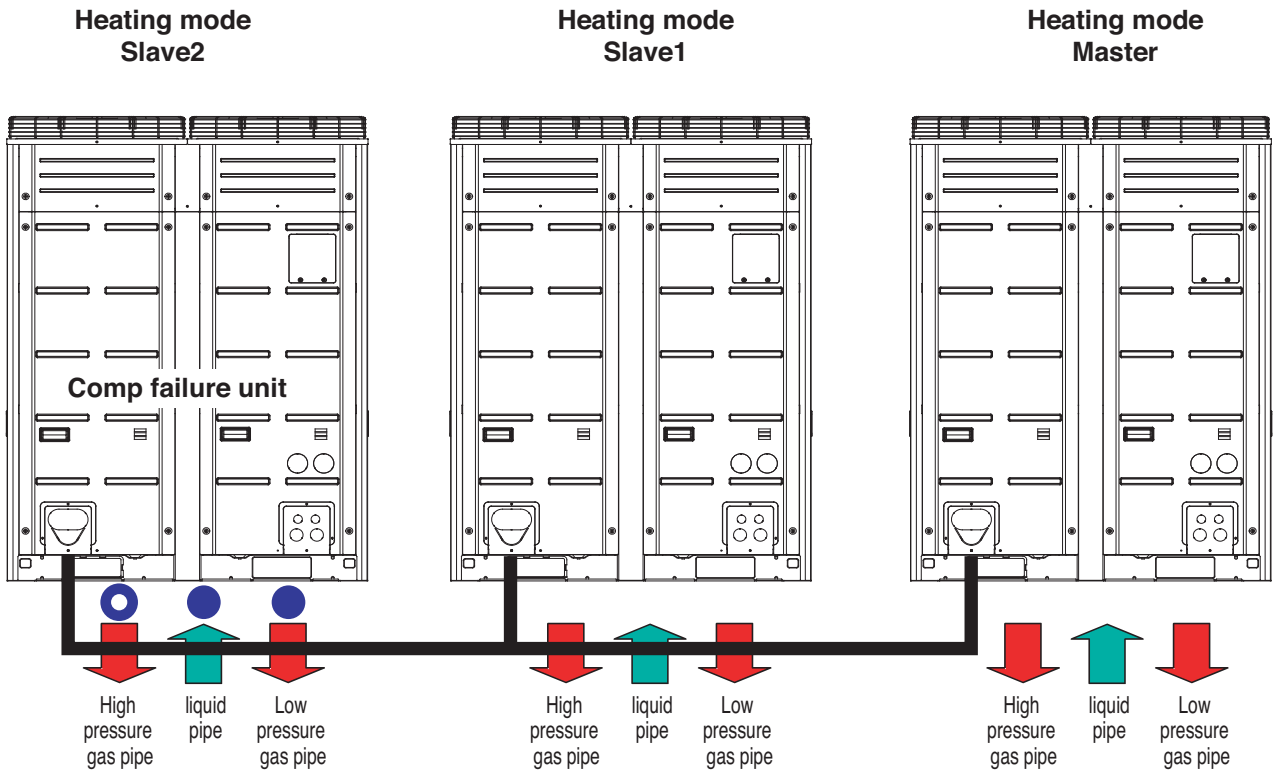

- : Close from step 1
- : Close from step 3

[Step]

1. Close liquid pipe and low pressure gas pipe of the comp failure unit for pump out operation.
2. Operate pump out.
3. Close high pressure gas pipe of comp failure unit after completion.
4. End pump out.
5. Eliminate refrigerant in suction port (For eliminate refrigerant port) after opening the high pressure pipe of corresponding outdoor unit. Replace compressor and perform vacuum.
6. Add the refrigerant with auto charging function.

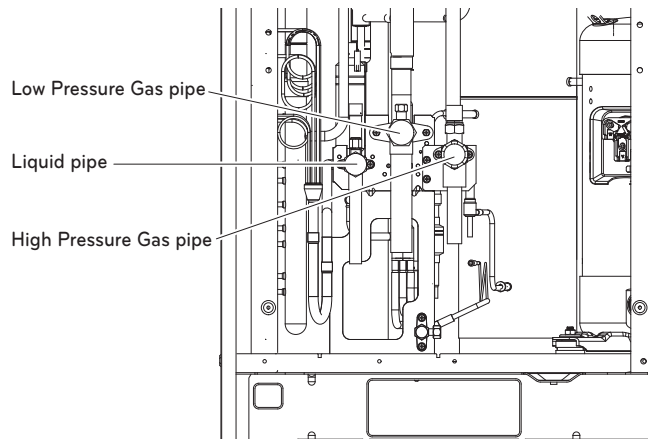

### 4.12 Auto Back Up Function\_Inverter compressor

This function allows the system to operate in case of inverter compressor failure by backing up compressor automatically.

SVC can be asked by displaying error to the customer every 6 hours.

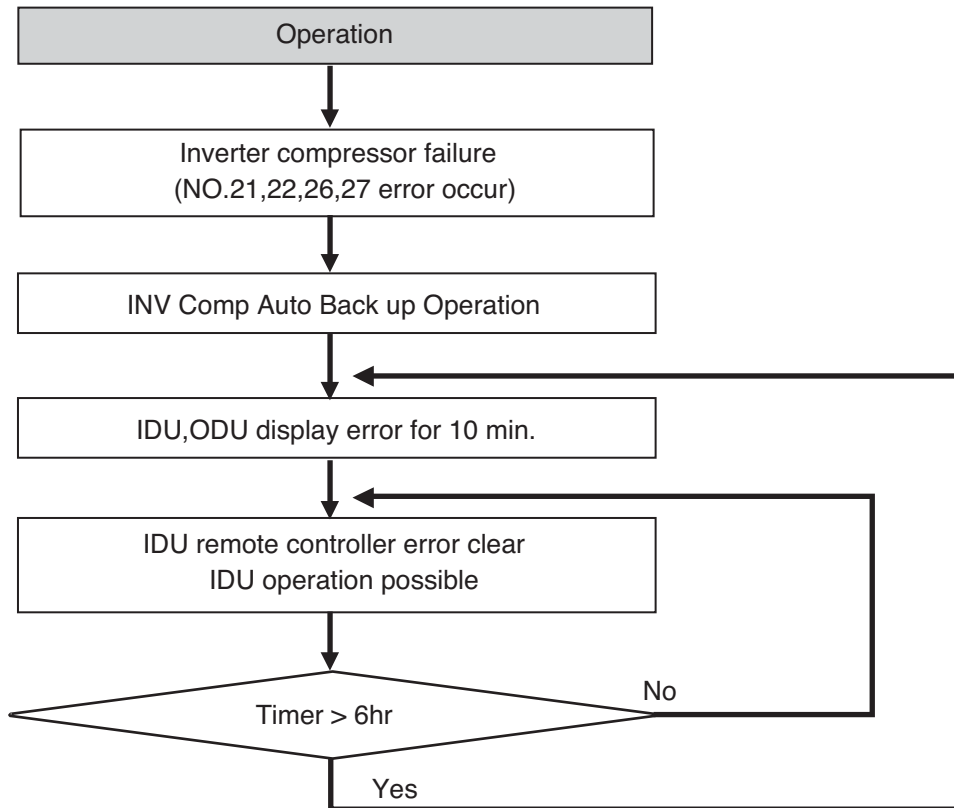

#### Example) Slave1 unit Inverter Compressor 1 start failure error No. 21 occur

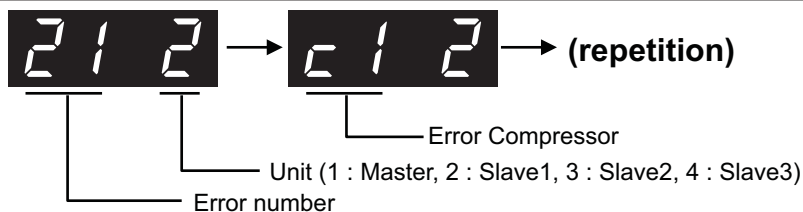

#### ⚠ Caution

1. Request SVC immediately if error occurs.
2. Auto back up is set up to 1 inverter Comp
3. If Inverter Comp Auto Back up starts, error displays for 10 min. every 6 hours.
4. Error displays continuously at the corresponding ODU.

### 4.13 Night Low Noise Function

In cooling mode, this function makes the ODU fan operate at low RPM to reduce the fan noise of ODU at night which has low cooling load.

#### Night low noise function setting method

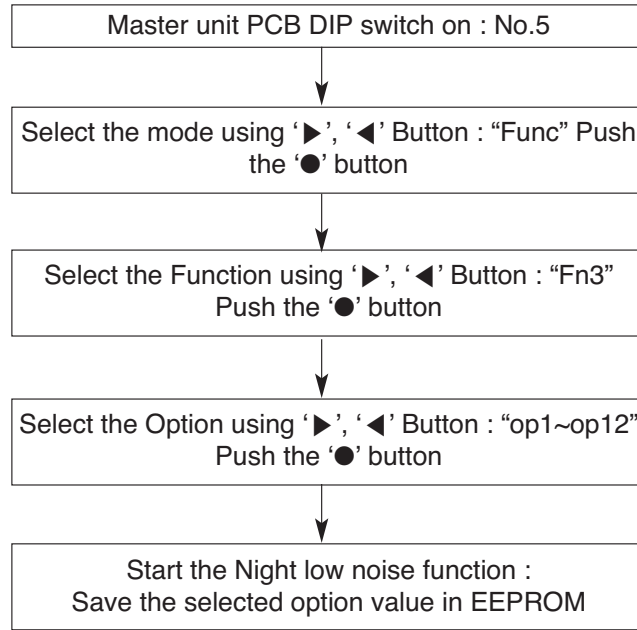

RPM / Time Settings

Step	Judgment Time(Hr)	Operation Time(Hr)
op1	8	9
op2	6.5	10.5
op3	5	12
op4	8	9
op5	6.5	10.5
op6	5	12
op7	8	9
op8	6.5	10
op9	5	12
op10	Continuous operation	
op11		
op12		

Noise

Heat Recovery	Capacity	
	8 ~ 12HP	14 ~ 20HP
Step	Noise(dB)	
op1~op3, op10	55	59
op4~op6, op11	52	56
op7~op9, op12	49	53

 **CAUTION**

- Request installer to set the function during installation.
- In case the function is not used, set the dip S/W OFF and reset the power.
- If ODU RPM changes, cooling capacity may go down.

## 4.14 Vacuum Mode

This function is used for creating vacuum in the system after compressor replacement, ODU parts replacement or IDU addition/replacement.

### Vacuum mode setting method

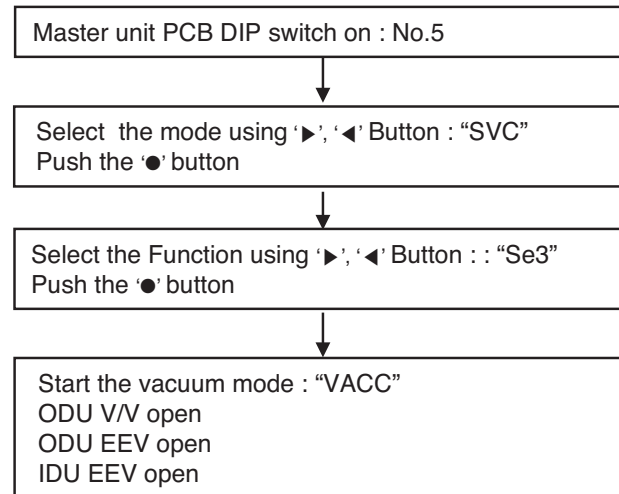

### Vacuum mode cancellation method

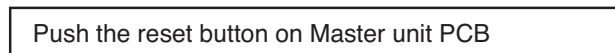

## CAUTION

ODU operation stops during vacuum mode. Compressor can't operate.

## 4.15 Static pressure compensation mode

This function is used for creating vacuum in the system after compressor replacement, ODU parts replacement or IDU addition/replacement.

### Static pressure compensation mode setting method

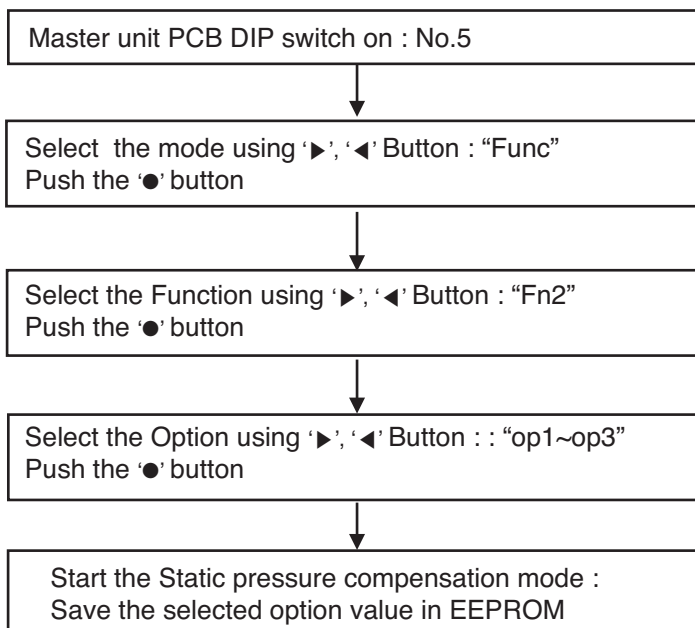

### FAN Maximum RPM of each step

Capacity		8 ~ 12HP	14 ~ 20HP
Max. RPM	Standard	730	950
	Step1	800	1020
	Step2	820	1050
	Step3	850	1110

## 4.16 Cool & Heat selector

### mode setting method

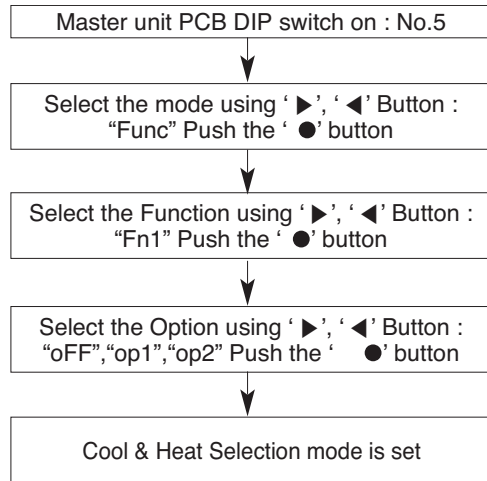

### mode setting method

Switch control		Function		
Switch(Phase)	Switch(Bottom)	oFF	op1(mode)	op2(mode)
Right	Left	Not operate	Cooling	Cooling
Right	Right	Not operate	Heating	Heating
Left	-	Not operate	Fan mode	Off

Left side | Right side

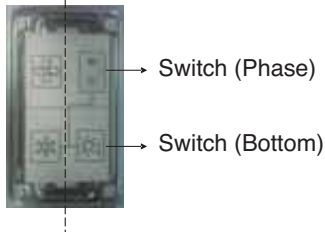

### **!** CAUTION

- Ask an authorized technician to setting a function.
- If do not use a function, set an off-mode.
- If use a function, first install a Cool & Heat selector.

## 4.17 Cycle Data View

This function is intended to identify the Cycle data of ODU, which is running on.

The 7 Segment is display 26 different cycle data.

### Cycle data view function setting method

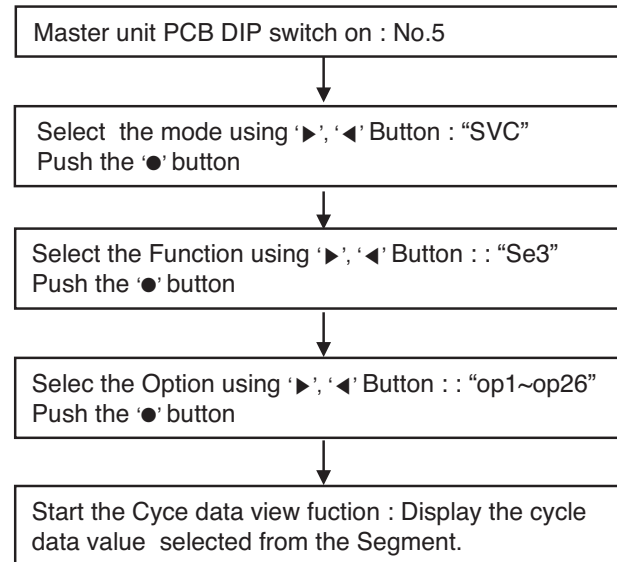

step	Title	7-seg	example	seg_1	seg_2	seg_3	seg_4
op1	Current High Pressure	P1	4321kPa	4	3	2	1
op2	Current low Pressure	P2	1234kPa	1	2	3	4
op3	Inv 1 Pulse	h1	120		1	2	0
op4	Inv 2 Pulse	h2	30			3	0
op5	fan rpm	h3	110		1	1	0
op6	Subcooling degree	T1	5.3			5	3
op7	Superheating degree	T2	-4.5		-	4	5
op8	ODU temp.	T3	10		1	0	0
op9	Suctino temp.	T4	43.4		4	3	4
op10	Comp1 discharge temp.	T5	150		1	5	0
op11	Comp2 discharge temp.	T6	124		1	2	4
op12	Liquid pipe temp.	T7	10		1	0	0
op13	Sc_in	T8	10		1	0	0
op14	Sc_out	T9	10		1	0	0
op15	hex_total	T10	10		1	0	0
op16	hex_hi	T11	10		1	0	0
op17	hex_low	T12	10		1	0	0
op18	Inlet pipe temp of IDU	T13	-10°	-	1	0	0
op19	main1 eev	PLS1	1940	1	9	4	0
op20	main2 eev	PLS2	32			3	2
op21	sc eev	PLS3	16			1	6
op22	oil eev	PLS4	50			5	0
op23	vi eev 1	PLS5	1350	1	3	5	0
op24	vi eev 2	PLS6	8				8
op25	IDU running capacity	IDU1	24k			2	4
op26	Total number of IDU	IDU2	10			1	0

# Part 3

## HR Units

# HR Units

<b>1. Specifications .....</b>	<b>52</b>
<b>2. Parts Functions .....</b>	<b>53</b>
<b>3. Dimensions .....</b>	<b>54</b>
<b>4. Piping Diagrams .....</b>	<b>55</b>
<b>5. Wiring Diagrams .....</b>	<b>56</b>
<b>6. Functions .....</b>	<b>57</b>

# Specifications

## 1. HR Unit

Model		PRHR021	PRHR031	PRHR041	
Max. Connectable No. of Indoor Units		16	24	32	
Max. Connectable No. of Indoor Units of a branch		8	8	8	
Nominal Input	Cooling	26	40	40	
	Heating	26	40	40	
Net. Weight	kg	18	20	22	
	lbs	39.7	44.1	48.5	
Dimensions (WxHxD)	mm	801x218x617	801x218x617	801x218x617	
	Inch	31.5x8.6x24.3	31.5x8.6x24.3	31.5x8.6x24.3	
Casing		Galvanized steel plate			
Connecting Pipes	Indoor	Liquid Pipe [mm/inch]	Ø9.52[3/8]		
		Gas Pipe [mm/inch]	Ø15.88[5/8]		
	Outdoor	Liquid [mm/inch]	Ø9.52[3/8]	Ø12.7[1/2]	Ø15.88[5/8]
		Low Pressure [mm/inch]	Ø22.2[7/8]	Ø28.58[1 1/8]	Ø28.58[1 1/8]
		High Pressure [mm/inch]	Ø19.05[3/4]	Ø22.2[7/8]	Ø22.2[7/8]
Sound Absorbing Insulation Material		Polyethylene Foam			
Current	Minimum circuit Amps(MCA)	0.2			
	Maximum fuse Amps(MFA)	15			
Power Supply		1Ø, 220-240V, 50Hz / 1Ø, 220, 60Hz			

**Notes:**

1. Voltage range : Units are suitable for sue on electrical systems where voltage supplied to units terminals is not below or above listed range limits.
2. Maximum allowable voltage unbalance between phases is 2%
3. MCA/MFA  $MCA = 1.25 * FLA$   
 $MFA \leq 4 * FLA$   
 (Next lower standard fuse rating. Min. 15A)
4. Select wire size based on the MCA
5. Instead of fuse, use circuit.

# Parts Functions

## 1. Parts Functions

Parts name	Symbol	Major function
Low pressure gas pipe	LPGV	Pipe for low pressure gas
High pressure gas pipe	HPGV	Pipe for high pressure gas
Liquid pipe 1	LP1	Liquid pipe connected with outdoor unit
Liquid bypass valve	LBV	Prevent liquid charging
Solenoid assembly 1, 2	SOL1, 2	Control the path for heating or cooling
Liquid pipe 2	LP2	Liquid pipe connected with indoor unit
Gas pipe	GSP	Gas pipe connected with indoor unit
Balancing valve	BLV	Control the pressure between High and Low pressure pipe during operation switching
Subcooling EEV	SCEEV	Control the subcooling

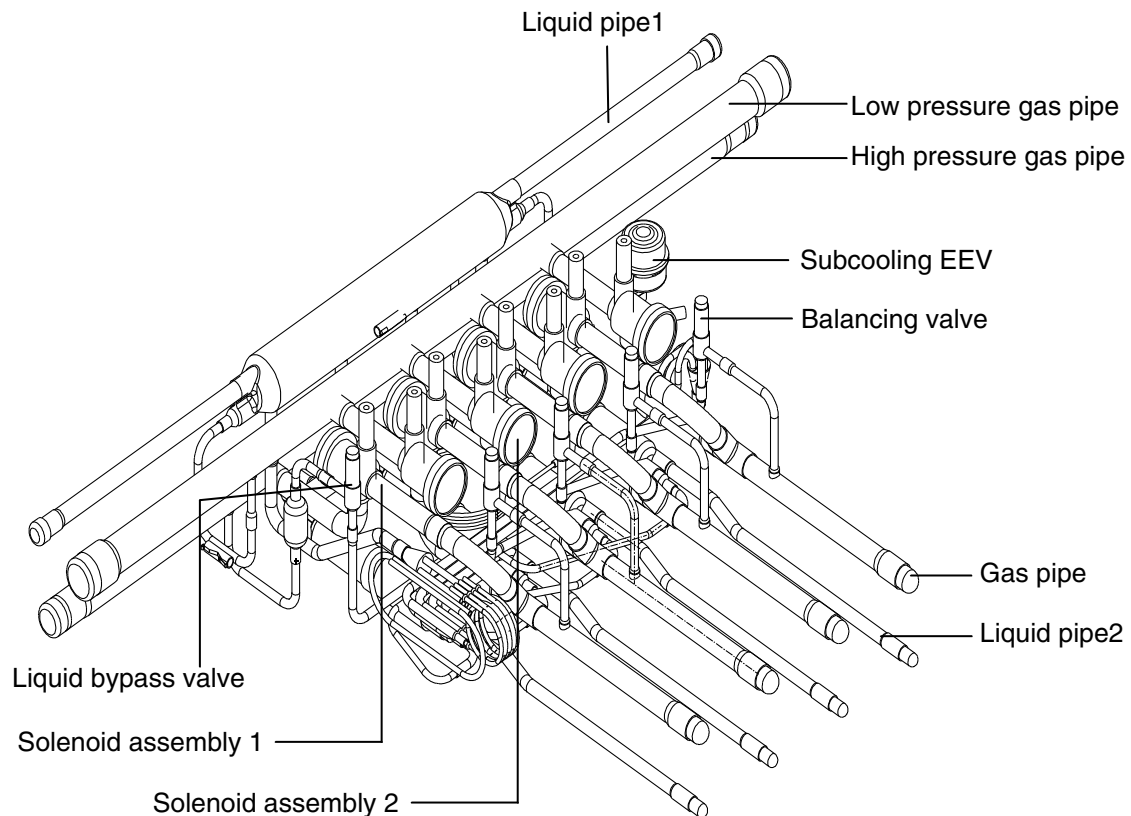

# Dimensions

## 1. HR Units

PRHR021  
PRHR031  
PRHR041

(Unit : mm(inch))

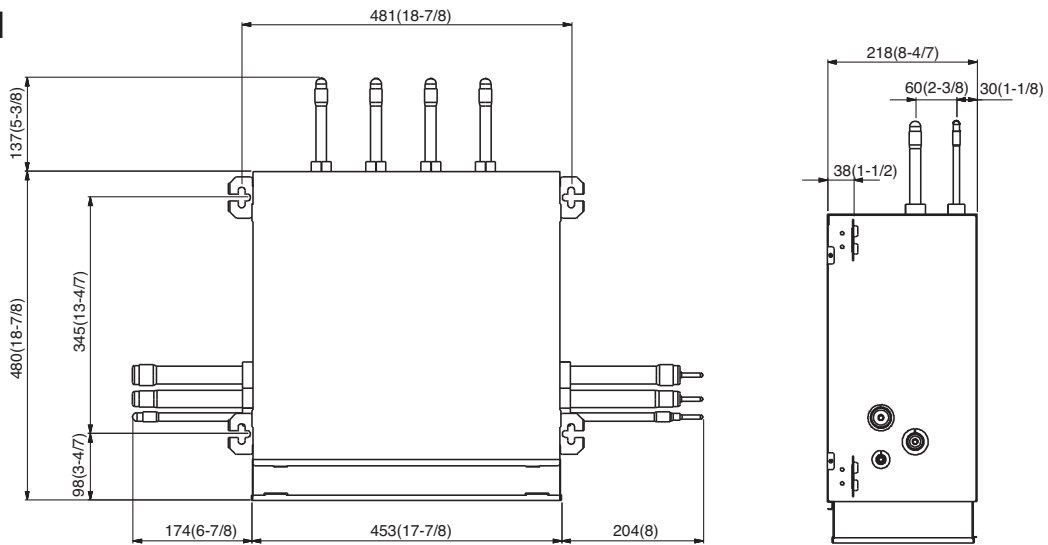



# Wiring Diagrams

## 1. HR Units

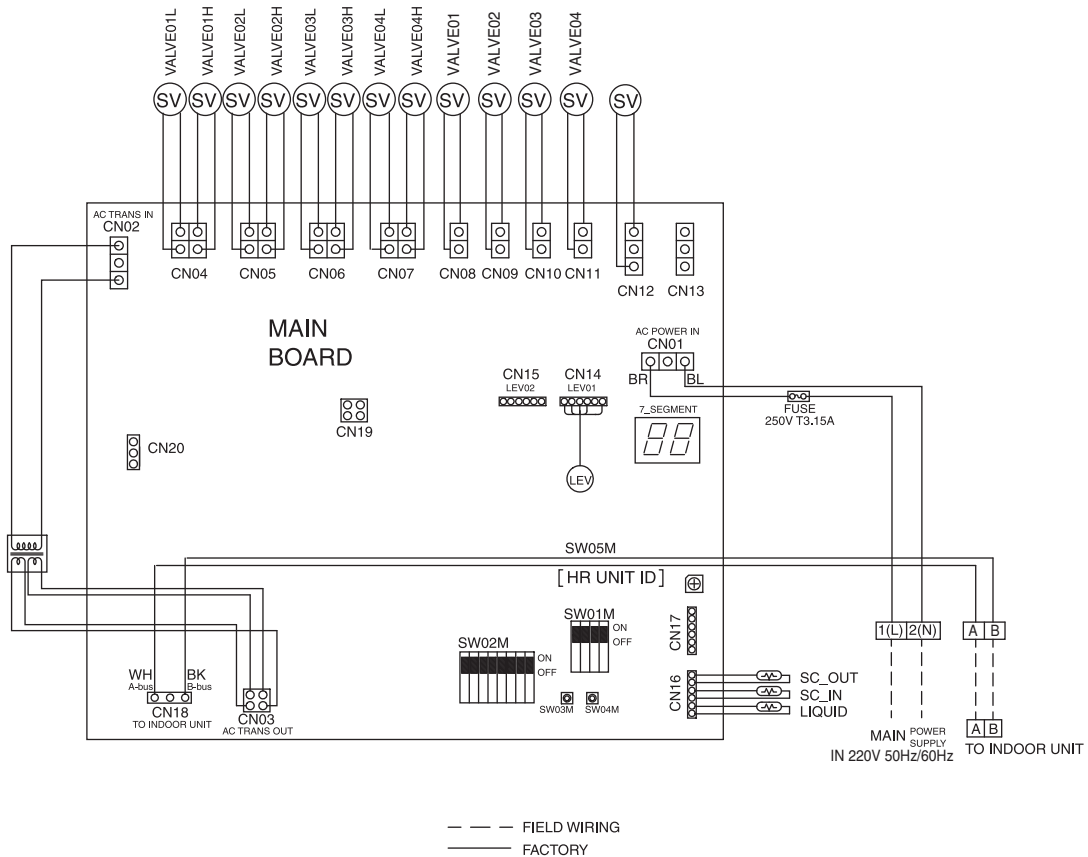

CN04	Solenoid valve 01L/H(For room1)
CN05	Solenoid valve 02L/H(For room2)
CN06	Solenoid valve 03L/H(For room3)
CN07	Solenoid valve 04L/H(For room4)
CN08	Solenoid valve 01 (Bypass for room1)
CN09	Solenoid valve 02 (Bypass for room2)
CN10	Solenoid valve 03 (Bypass for room3)
CN11	Solenoid valve 04 (Bypass for room4)
CN12	Solenoid valve bypass
CN14	Sub cooling EEV
CN16(SC Out)	Sensor, sub cooling out
CN16(SC In)	Sensor, sub cooling in
CN18(Liquid)	Sensor, liquid receiver
SW01M	Solenoid valve number Setting(When manual address)
SW02M(1)	Selecting, auto address(↓) or manual address(↑)
SW02M(2~3)	Setting, total number of indoor connected
SW03M	Setting, the address of indoor_10(When manual address)
SW04M	Setting, the address of indoor_1(When manual address)
SW05M	Setting, HR unit number

# Functions

## 1. Basic Control

### 1.1 Normal Operation

Actuator	Power on	Cooling operation	Heating operation	Stop state
High pressure gas valve	Close	Close	Open	Keep
Low pressure gas valve	After 30 sec. Open	Open	Close	Keep
Liquid valve	Close	Open	Close	Close

### 1.2 Starting Control(Heating Mode Only)

If the system is operated in the heating mode, all high pressure gas valves are opened

### 1.3 Valve Control

Mode change timer is calculated as Table 1, and valves are controlled by Mode change timer according to Table 2.

Table 1. Mode change timer calculation

Previous mode	Changing mode	Mode change timer
Stop or ventilation	Cooling or heating	120 sec
Cooling mode	Heating	180 sec
Heating mode	Cooling	120 sec
Cooling or heating	Stop or ventilation	During heating : 60 sec During cooling : 0 sec

Table 2. Valve control by mode change timer

Operating mode	Mode change timer	H/P gas valve	L/P gas valve	Balancing valve
Cooling	$120 \leq \text{timer}$	Keep	Keep	Close
	$0 < \text{timer} < 120$	Close	Close	Open
	$\text{timer} = 0$	Close	Open	Close
Heating	$180 \leq \text{timer}$	Keep	Keep	Close
	$0 < \text{timer} < 180$	Close	Close	Close
	$\text{timer} = 0$	Open	Close	Close
Stop or ventilation	$0 < \text{timer} \leq 5$	Cooling mode : Close	Keep	Close
	Timer = 0	Heating mode : Low pressure gas valve → Close	Keep	Close

## 2. Special Control

### 2.1 Oil Return/Defrost Control

Component	Starting	Running	Ending
Inverter compressor	Stop	60 Hz	40 Hz
High pressure gas valve	Keep	Close	Open or Close
Low pressure gas valve	Keep	Open	Open or Close
Balancing valve	Open for 30s	Close	Close

### 2.2 Liquid Bypass Control

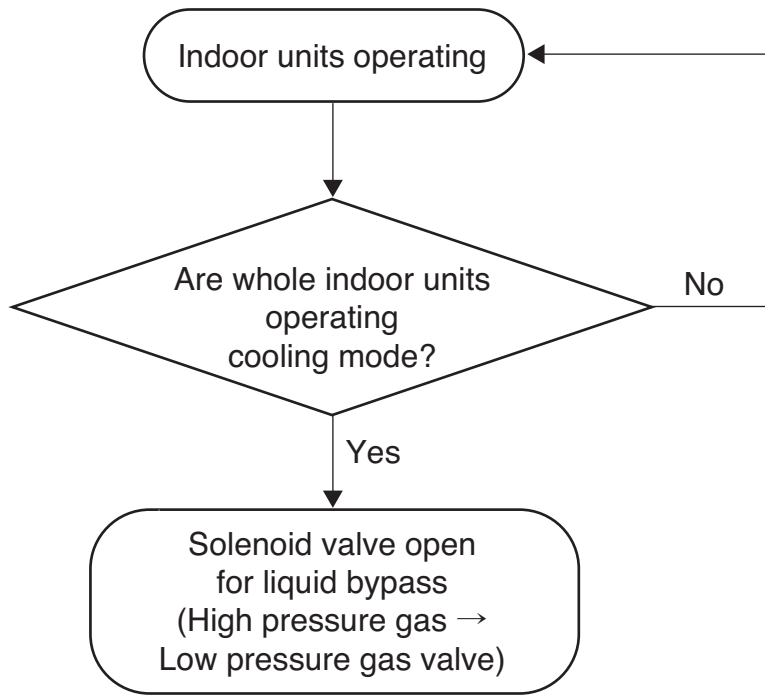

### 2.3 Subcooling EEV Control

Target : about 25°C(77°F)

Subcooling EEV works with Fuzzy rules to keep the degree of subcooling at the outlet of subcooler during simultaneous operation

The degree of subcooler = T outlet of subcooler – T inlet of subcooler

# Part 4

## PCB Setting and Test Run

# PCB Setting and Test Run

<b>HR Unit PCB .....</b>	<b>63</b>
<b>1. Switch for Setup of HR Unit .....</b>	<b>63</b>
<b>2. Method for Addressing of Indoor and HR Unit.....</b>	<b>68</b>
<b>3. Flow Chart for Auto-Addressing of Indoor and HR Unit .....</b>	<b>70</b>
<b>4. Example of Manual Valve Addressing.....</b>	<b>73</b>
<b>5. Example of Checking Valve Address .....</b>	<b>74</b>
<b>6. Identification of Manual Valve ID (Address) .....</b>	<b>75</b>
<b>Test Run .....</b>	<b>76</b>
<b>1. Checks Before Test Run.....</b>	<b>76</b>
<b>2. How to Cope with Test Run Abnormality.....</b>	<b>77</b>
<b>3. Dip Switch Setting.....</b>	<b>78</b>

# HR Unit PCB

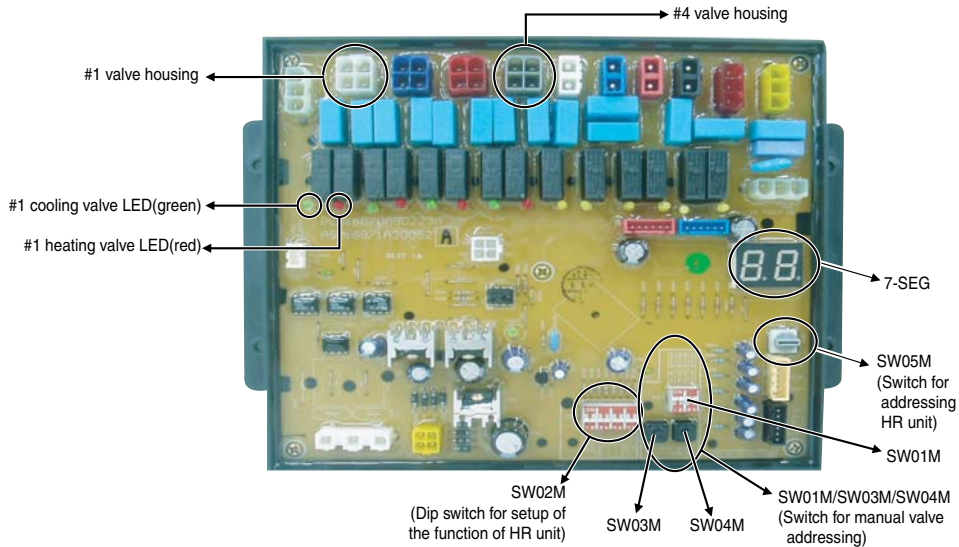

## 1. Switch for Setup of HR Unit



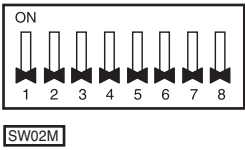

### 1. Main function of SW02M

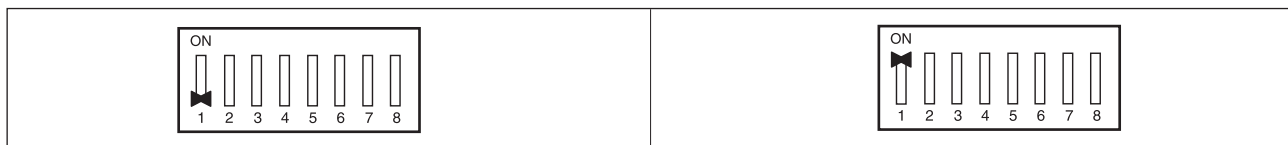
 SW02M	ON switch	Selection	
	No.1	Method for addressing valves of an HR unit (Auto/Manual)	
	No.2	Model of HR unit	
	No.3	Model of HR unit	
	No.4	Valve group setting	
	No.5	Valve group setting	
	No.6	Valve group setting	
	No.7	Use only in factory production (preset to "OFF")	Zoning setting ("ON")
	No.8	Use only in factory production (preset to "OFF")	

#### 1) Selection of the method for addressing valves of an HR unit (Auto/Manual)



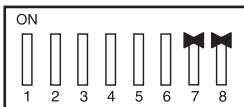



#### 2) Setting the zoning control

	DIP S/W setting	
Normal control		 SW01M
Zoning control		 SW01M

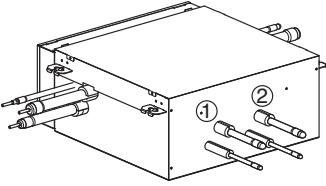
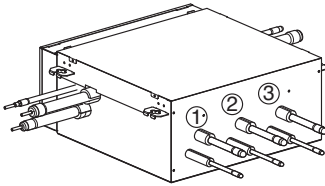
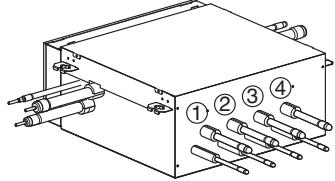
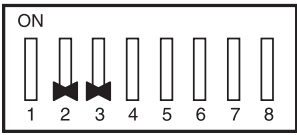
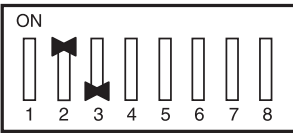
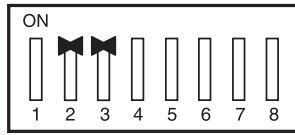
Turn the dip switch of the zoning branch on.  
Ex) Branch 1,2 are zoning control.

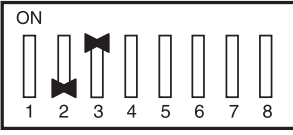
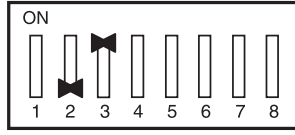
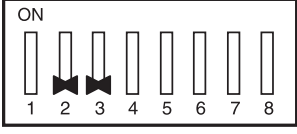
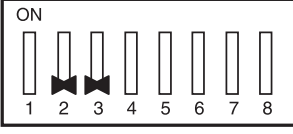
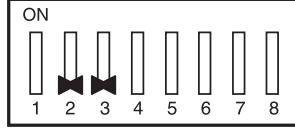
2) Selection of the model of the HR unit

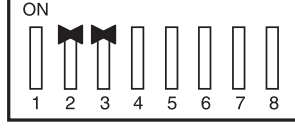



	 <p>(For 2 branches) PRHR021</p>	 <p>(For 3 branches) PRHR031</p>	 <p>(For 4 branches) PRHR041</p>
Initial Setting			
1 branches Connected			
2 branches Connected			
3 branches Connected			
4 branches Connected			

\* Each model is shipped with the switches No.2 and No.3 pre-adjusted as above in the factory.

**! WARNING**

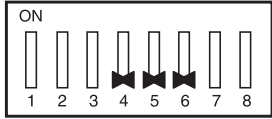
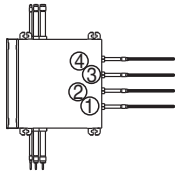
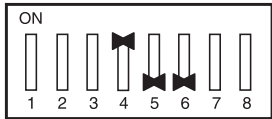
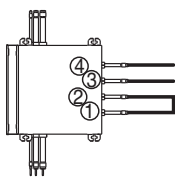
- If you want to use a PRHR021 for 2 branches HR unit after closing the 3rd pipes, set the dip switch for 2 branches HR unit.
- If you want to use a PRHR031 for 3 branches HR unit after closing the 4th pipes, set the dip switch for 3 branches HR unit.
- If you want to use a PRHR041 for 2 branches HR unit after closing the 3rd and 4th pipes, set the dip switch for 2 branches HR unit.
- The unused port must be closed with a copper cap, not with a plastic cap.

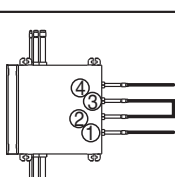
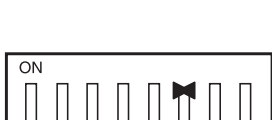
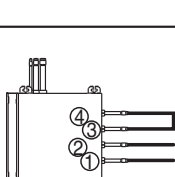
3) Setting the Valve group.

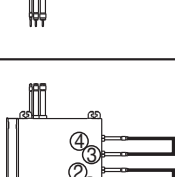
	Dip switch setting	Example
Not control		 Indoor unit Indoor unit Indoor unit Indoor unit
No.1, 2 valve control		 Indoor unit Indoor unit Large capacity indoor unit
No.2, 3 valve control		 Indoor unit Large capacity indoor unit Large capacity indoor unit Indoor unit
No.3, 4 valve control		 Large capacity indoor unit Indoor unit Indoor unit Indoor unit
No.1, 2 valve / No.3, 4 valve control		 Large capacity indoor unit Large capacity indoor unit Indoor unit Indoor unit

**Note:**

If the large capacity indoor units are installed, below Y branch pipe should be used

**\* Y branch pipe**

[Unit:mm(inch)]

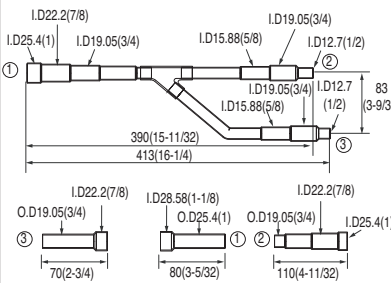
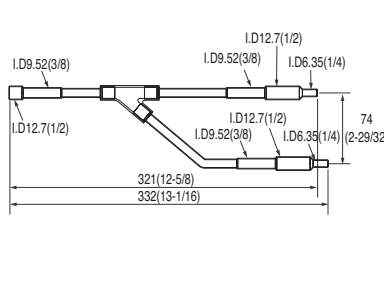
Models	Low Pressure Gas Pipe	Liquid pipe
ARBLB03321		

## 2. SW05M (Rotary switch for addressing HR unit)

Must be set to '0' when installing only one HR unit.

When installing multiple HR units, address the HR units with sequentially increasing numbers starting from '0'.

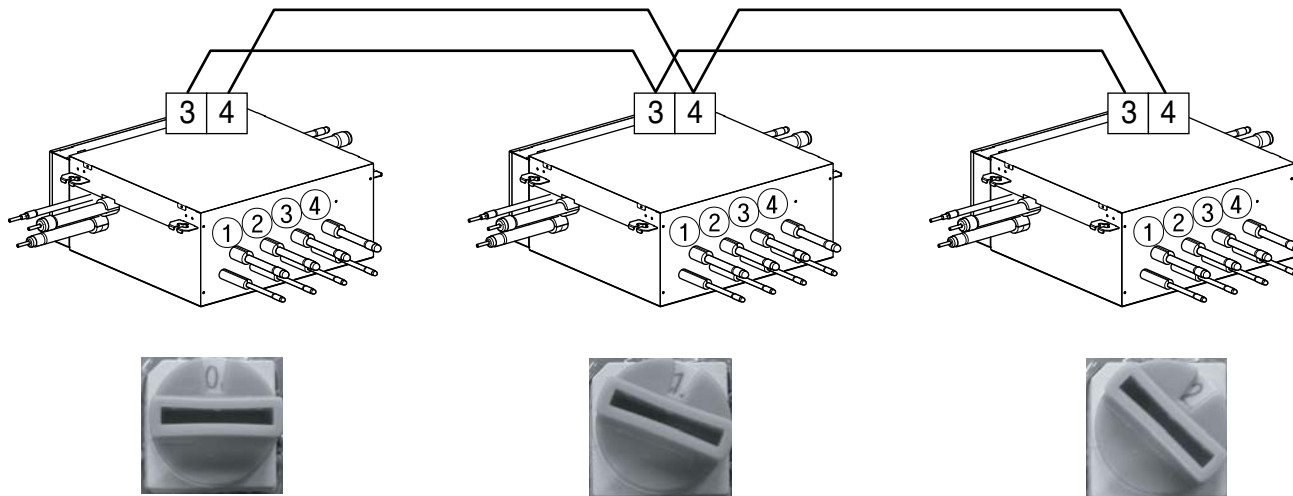

Ex) Installation of 3 HR units



## 3. SW01M/SW03M/SW04M (Dip switch and tact switch for manual valve addressing)



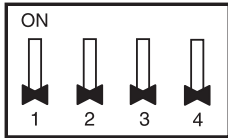

1) Normal setting (Non-Zoning setting)

- Used in manual addressing of the valve in the HR unit
- Set the address of the valve of the HR unit to the central control address of the connected indoor unit.
- SW01M: selection of the valve to address  
SW03M: increase in the digit of 10 of valve address  
SW04M: increase in the last digit of valve address
- Prerequisite for manual valve addressing : central control address of each indoor unit must be preset differently at its wired remote control.

	Switch No.	Setup
 SW01M	No.1	Manual addressing of valve #1
	No.2	Manual addressing of valve #2
	No.3	Manual addressing of valve #3
	No.4	Manual addressing of valve #4
 SW03M	SW03M	Increase in the digit of 10 of valve address
 SW04M	SW04M	Increase in the last digit of valve address

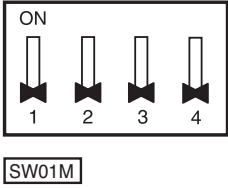
2) Zoning setting

- Set the address of the valve of the HR unit to the central control address of the connected indoor unit.
- SW01M : selection of the valve to address  
 SW03M : increase in the digit of 10 of valve address  
 SW04M : increase in the last digit of valve address  
 SW05M :Rotary S/W
- Prerequisite for manual valve addressing : central control address of each indoor unit must be preset differently at its wired remote control.

	S/W No.	Setup
	No.1	Manual addressing of valve #1
	No.2	Manual addressing of valve #2
	No.3	Manual addressing of valve #3
	No.4	Manual addressing of valve #4
	SW03M	Increase in the digit of 10 of valve address
	SW04M	Increase in the last digit of valve address
	SW05M	Manual addressing of zoning indoor units

## 2. Automatic Addressing

### The address of indoor units would be set by Automatic Addressing

- Wait for 3 minutes after supplying power.  
(Master and Slave outdoor units, indoor units)
- Press RED button of the outdoor units for 5 seconds. (SW01C)
- A "88" is indicated on 7-segment LED of the outdoor unit PCB.
- For completing addressing, 2~7 minutes are required depending on numbers of connected indoor units
- Numbers of connected indoor units whose addressing is completed are indicated for 30 seconds on 7-segment LED of the outdoor unit PCB
- After completing addressing, address of each indoor unit is indicated on the wired remote control display window. (CH01, CH02, CH03, ....., CH06 : Indicated as numbers of connected indoor units)

#### ■ Heat Recovery (MAIN PCB)

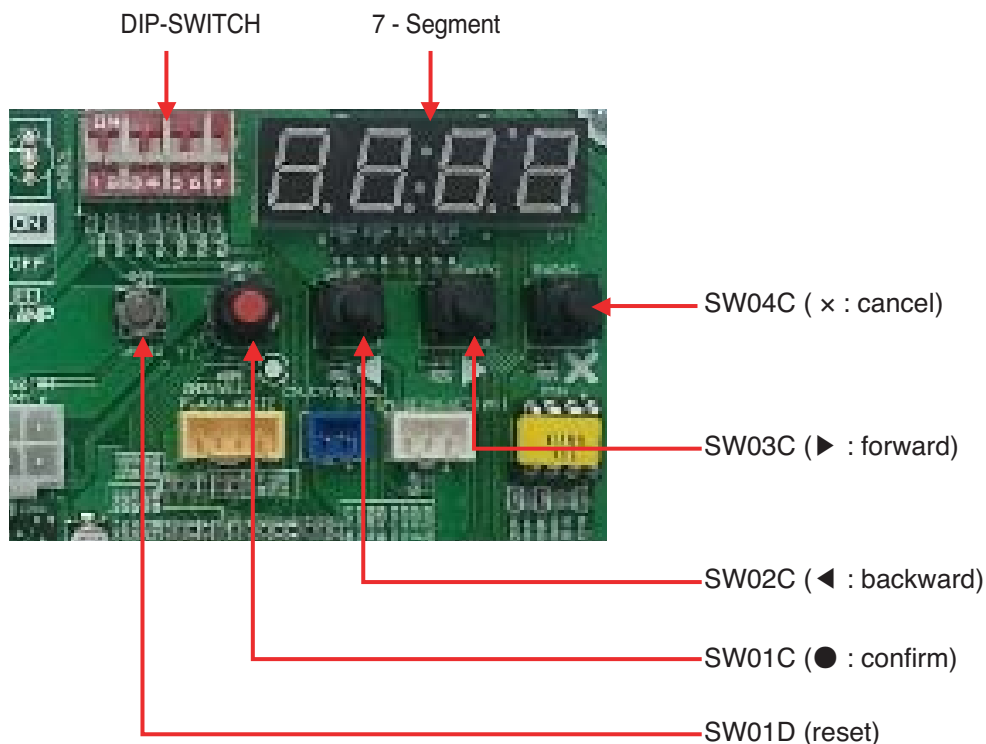

#### ⚠ CAUTION

- In replacement of the indoor unit PCB, always perform Automatic addressing setting again (At that time, please check about using Independent power module to any indoor unit.)
- If power supply is not applied to the indoor unit, operation error occur.
- Automatic Addressing is only possible on the master Unit.
- Automatic Addressing has to be performed after 3 minutes to improve communication.

### 3. Flow chart for Chart for Auto-Addressing of Indoor and HR Unit

#### 1) The Procedure of Automatic Addressing

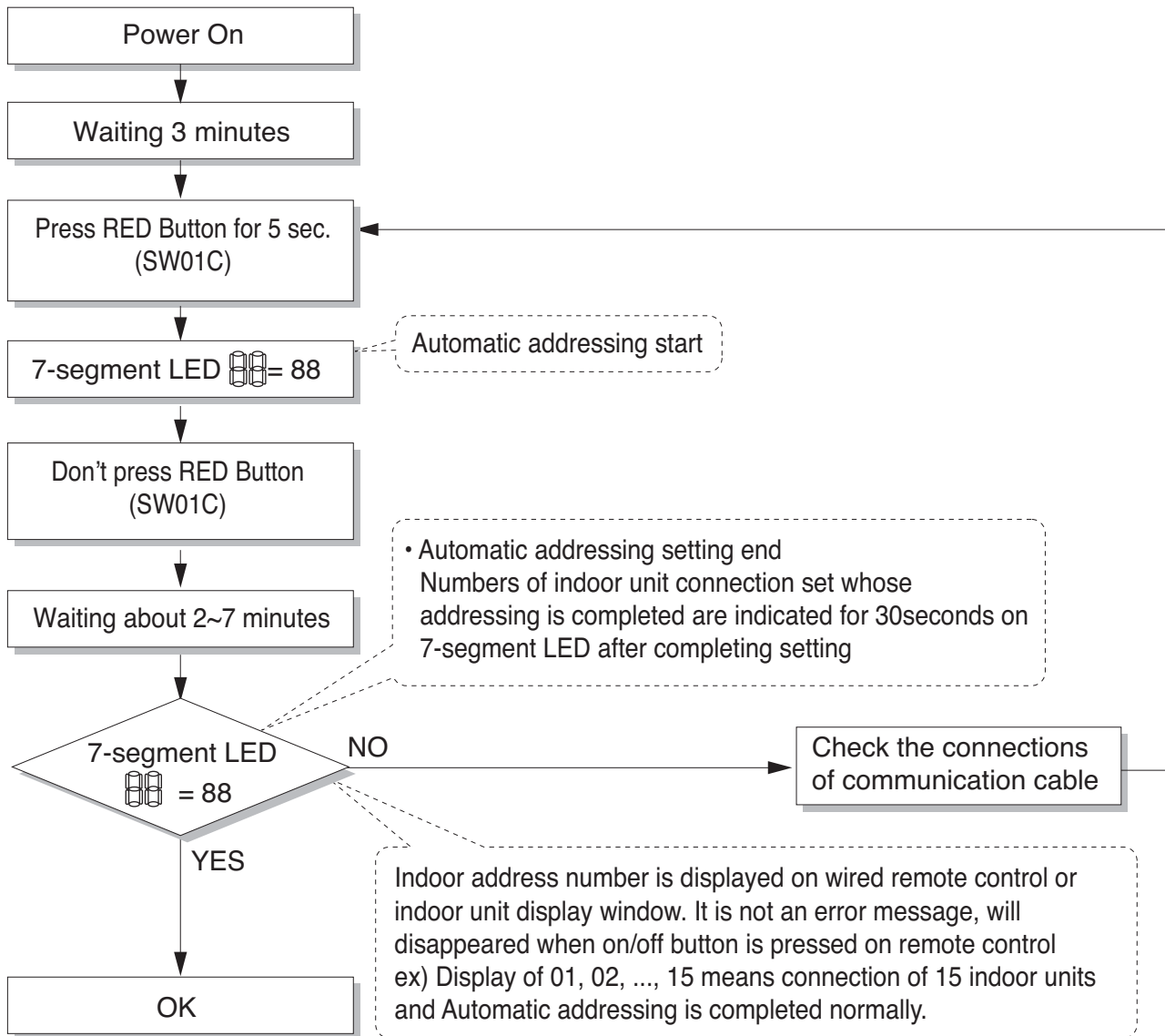

## 2) Flow chart of auto addressing for pipe detection

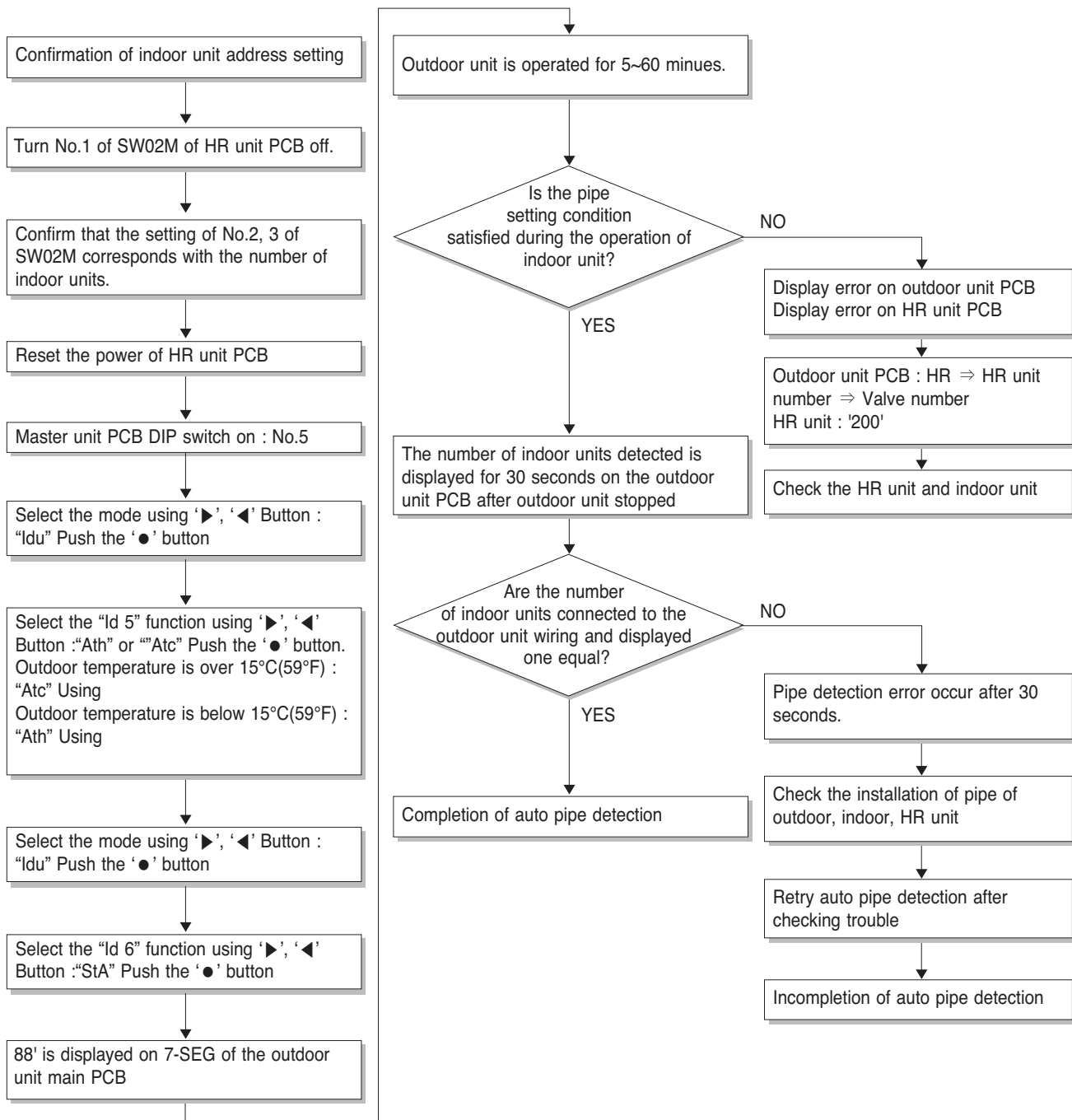

※ It is possible to be generated mode changing noise of heating and cooling which is normal. There is no mode changing noise at normal operation.



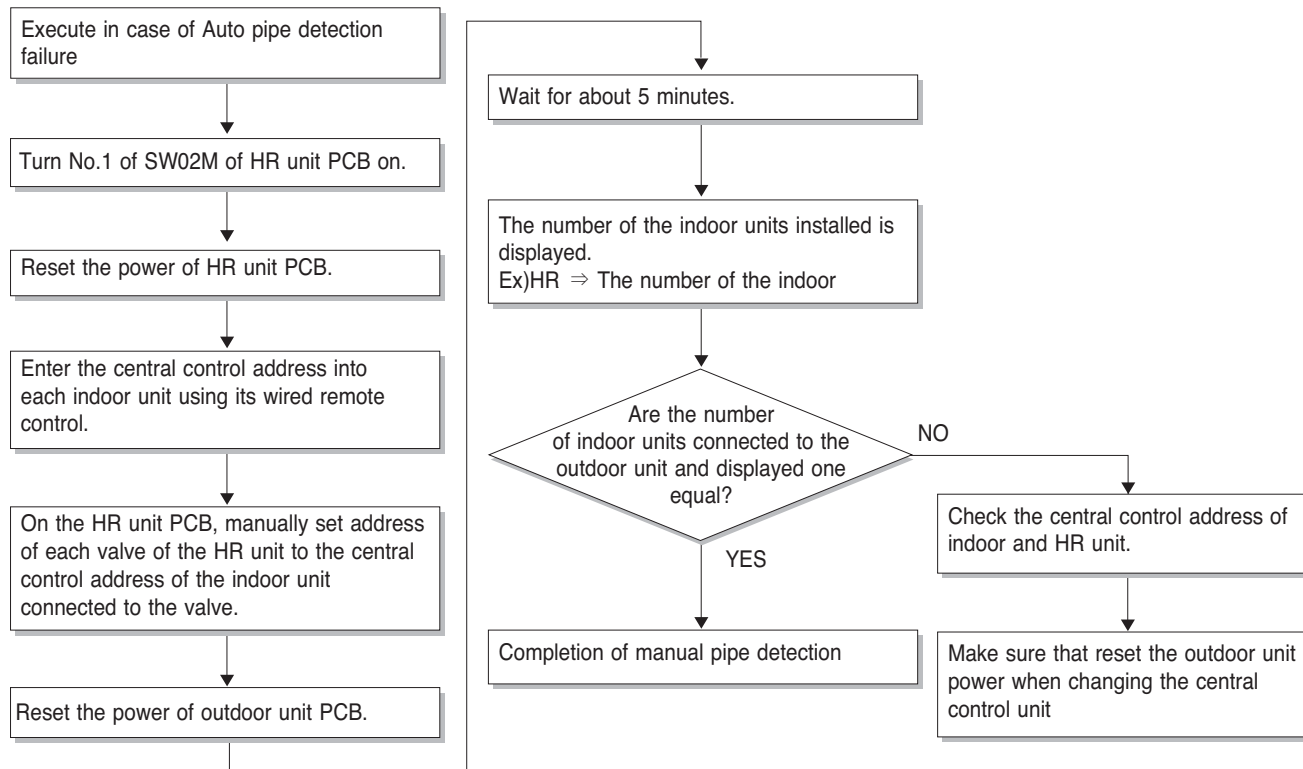

### 3) Flow chart of manual addressing for pipe detection



## 4. Example of Manual Valve Addressing(Non-Zoning setting)

(In case that an indoor unit of central control address "11" is connected to a valve #1 of an HR unit)

- Prerequisite for manual valve addressing: central control address of each indoor unit must be preset differently at its wired remote control

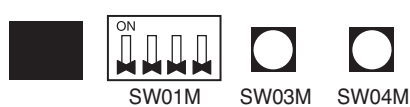
No.	Display and setup	Setup and contents
1		<ul style="list-style-type: none"> <li>• Operation: None</li> <li>• Display: None</li> </ul>
2		<ul style="list-style-type: none"> <li>• Operation: Turn No.1 of SW01M on to address valve #1</li> <li>• Display: Existing value saved in EEPROM is displayed in 7-SEG.</li> </ul>
3		<ul style="list-style-type: none"> <li>• Operation: Set the digit of 10 to the number in group high data of the wired remote control connected to the corresponding indoor unit to the valve #1 by pressing SW03M.</li> <li>• Display: Digit increasing with the times of pressing tack switch is displayed in left 7-SEG</li> </ul>
4		<ul style="list-style-type: none"> <li>• Operation: Set the digit of 1 to the number in group low data of the wired remote control connected to the corresponding indoor unit to the valve #1 by pressing SW04M.</li> <li>• Display: Digit increasing with the times of pressing tack switch is displayed in right 7-SEG</li> </ul>
5		<ul style="list-style-type: none"> <li>• Operation: Turn No.1 of SW01M off to save the address of valve #1</li> <li>• Display: "11" displayed in 7-SEG disappears</li> </ul>

- Above setup must be done for all HR unit valves.
- The valve that is not connected with any indoor unit should be addressed with any other number than used address numbers of the valves connected with indoor units.  
(The valves does not work if the address numbers are same.)

## 5. Example of manual valve addressing (Zoning setting)







(In case that an indoor unit of central control address "11" is connected to a valve #1 of an HR unit)

Zoning control is connecting 2 or more indoor units at one pipe of HR unit. In case of Zoning control, in order to set controls with multiple indoor units connection uses the rotary switch. Namely, only the rotary switch changes from same valve set condition and set indoor units connection.

- 1) On dip switch of the corresponding valves and sets the rotary switch at 0.
- 2) Setting the number with tact switch.
- 3) In case of addition of indoor units to same port, increases 1 with the rotary switch and sets number with tact switch.
- 4) In case of checking the number which the corresponding valve is stored, turn on dip switch and set the number of rotary switch.
- 5) Indoor units set available 7 per a port(rotary switch 0~6), in case of setting above of 7 with rotary switch, it will display error.
- 6) Setting the rotary switch on original condition(HR unit number set conditions) after all finishing a piping setting.
- 7) The rotary switch set value of above number of indoor units which is connected with FF and prevents a malfunction.

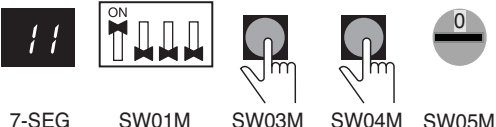
(Example: The case where 3 indoor units is connected in piping 1, sets from rotary switch 0,1,2 and 3,4,5 with FF set)

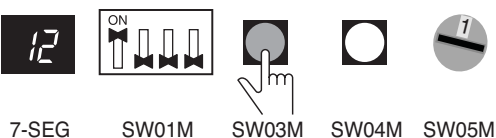
- Prerequisite for manual valve addressing: central control address of each indoor unit must be preset differently at its wired remote control.

No.	Display and setup	Setup and Contents
1	 7-SEG SW01M SW03M SW04M SW05M	<ul style="list-style-type: none"> <li>• Operation: None</li> <li>• Display: None</li> </ul>
2	 7-SEG SW01M SW03M SW04M SW05M	<ul style="list-style-type: none"> <li>• Operation : Turn dip S/W No.1 on to address valve #1</li> <li>• Display : Existing value saved in EEPROM is displayed in 7-SEG.</li> </ul>
3	 7-SEG SW01M SW03M SW04M SW05M	<ul style="list-style-type: none"> <li>• Operation : Set the digit of 10(1) to the number in Group High data of the wired remote control connected to the corresponding indoor unit to the valve #1 by pressing left tact S/W.</li> <li>• Display : Digit increasing with the times of pressing tact S/W is displayed in left 7-SEG.</li> </ul>
4	 7-SEG SW01M SW03M SW04M SW05M	<ul style="list-style-type: none"> <li>• Operation : SW05M : 1</li> <li>• Display : Display former value.</li> </ul>
5	 7-SEG SW01M SW03M SW04M SW05M	<ul style="list-style-type: none"> <li>• Operation : Setting No. using SW03M and SW04M, SW05M : 1</li> <li>• Display : Display setting value.</li> </ul>
6	 7-SEG SW01M SW03M SW04M SW05M	<ul style="list-style-type: none"> <li>• Operation : Turn dip S/W No.1 off to save the address of valve #1</li> <li>• Display : "11" displayed in 7-SEG disappears.</li> </ul>
7	 7-SEG SW01M SW03M SW04M SW05M	<ul style="list-style-type: none"> <li>• Operation : Return valve of addressing HR unit.</li> <li>• Display : None</li> </ul>



- Above setup must be done for all HR unit valves.

- The valve that is not connected with any indoor unit should be addressed with any other number than used address numbers of the valves connected with indoor units.

(The valves does not work if the address numbers are same.)

## 6. Example of Checking Valve Address

(In case that an indoor unit of central control address "11" is connected to a valve #1 of an HR unit)

No.	Display and setup	Setup and contents
1		<ul style="list-style-type: none"> <li>• Operation: Turn dip switch No.1 on.</li> <li>• Display: "11" is displayed in 7-SEG</li> </ul>
2		<ul style="list-style-type: none"> <li>• Operation: Turn dip switch No.1 on.</li> <li>• 7-SEG disappeared</li> </ul>

## 7. Identification of Manual Valve ID (Address)

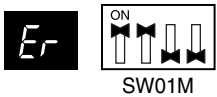
No.	Display and setup	Setup and contents
1		<ul style="list-style-type: none"> <li>• Operation: more than 2 dip switches turned on.</li> <li>• Display: "Er" is displayed in 7-SEG</li> </ul>

## 8. Method of checking the pipe detection result at outdoor unit

- 1) Wait for 5 minutes, after Pipe detection is completed.
- 2) Turn on the No.10,14,16 DIP S/W of Sub PCB at master unit
- 3) Check the data on 7- segment, switching rotary 01,02.

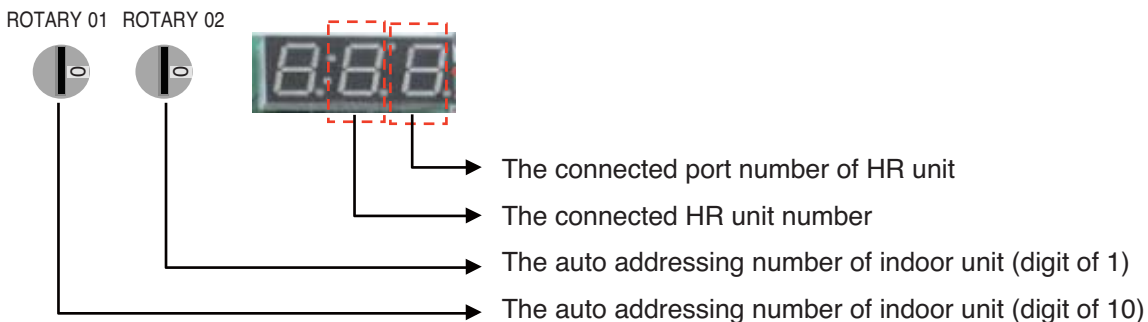

# Test Run

## 1. Checks Before Test Run

1	Check to see whether there is any refrigerant leakage, and slack of power or communication cable.
2	<p>Confirm that 500 V megger shows 2.0 MΩ or more between power supply terminal block and ground. Do not operate in the case of 2.0 MΩ or less.</p> <p>NOTE: Never carry out megaohm check over terminal control board. Otherwise the control board would be broken.</p> <p>Immediately after mounting the unit or after leaving it turned off for an extended length of time, the resistance of the insulation between the power supply terminal board and the ground may decrease to approx. 2 MΩ as a result of refrigerant accumulating in the internal compressor. If the insulation resistance is less than 2 MΩ, turning on the main power supply and energizing the crankcase heater for more than 6 hours will cause the refrigerant to evaporate, increasing the insulation resistance.</p>
3	<p>Check if high/low pressure common pipe, liquid pipe and gas pipe valves are fully opened.</p> <p>NOTE: Be sure to tighten caps.</p>
4	<p>Check if there are any problems in automatic addressing or not:</p> <p>Check and confirm that there are no error messages in the display of indoor units or remote controls and LED in outdoor units.</p>



### CAUTION

#### when cutting main power of the Multi V

- Always apply main power of the outdoor unit during use of product (cooling season/heating season).
- Always apply power before 4 hours to heat the crank case heater where performing test run after installation of product. It may result in burning out of the compressor if not preheating the crank case with the electrical heater for more than 4 hours.(In case of the outdoor temperature below 10°C)



### CAUTION

#### Preheat of compressor

- Start preheat operation for 4 hours after supplying main power.
- In case that the outdoor temperature is low, be sure to supply power 4 hours before operation so that the heater is heated(insufficient heating may cause damage of the compressor.)

## 2. How to cope with Test Run abnormality

### The phenomena from main component failure

Component	Phenomenon	Cause	Check method and Trouble shooting
<b>Compressor</b>	Not operating	Motor insulation broken	Check resistance between terminals and chassis
		Strainer clogged	Change strainer
		Oil leakage	Check Oil level after opening oil port
	Stop during running	Motor insulation failure	Check resistance between terminals and chassis
	Abnormal noise during running	R-S-T misconnection	Check compressor R-S-T connection
<b>Outdoor fan</b>	High pressure error at cooling	Motor failure, bad ventilation around outdoor heat exchanger	Check the outdoor fan operation after being turned the outdoor units off for some time. Remove obstacles around the outdoor units
<b>Outdoor EEV</b>	Heating failure, frequent defrosting	Bad connector contact	Check connector
	No operating sound at applying power	Coil failure	Check resistance between terminals
	Heating failure, frozen outdoor heat exchanger part	EEV clogged	Service necessary
	Low pressure error or discharge temperature error	EEV clogged	Service necessary

When system fault occurs, the error code is displayed at indoor unit display or remote control display, the trouble shooting guide is in the service manual

- When CH05/53/11 ERROR occurs, check if auto-addressing has done and communication wiring is ok.

### 3. DIP Switch Setting

#### ■ Location of setting Switch

##### Heat Recovery (Main PCB)

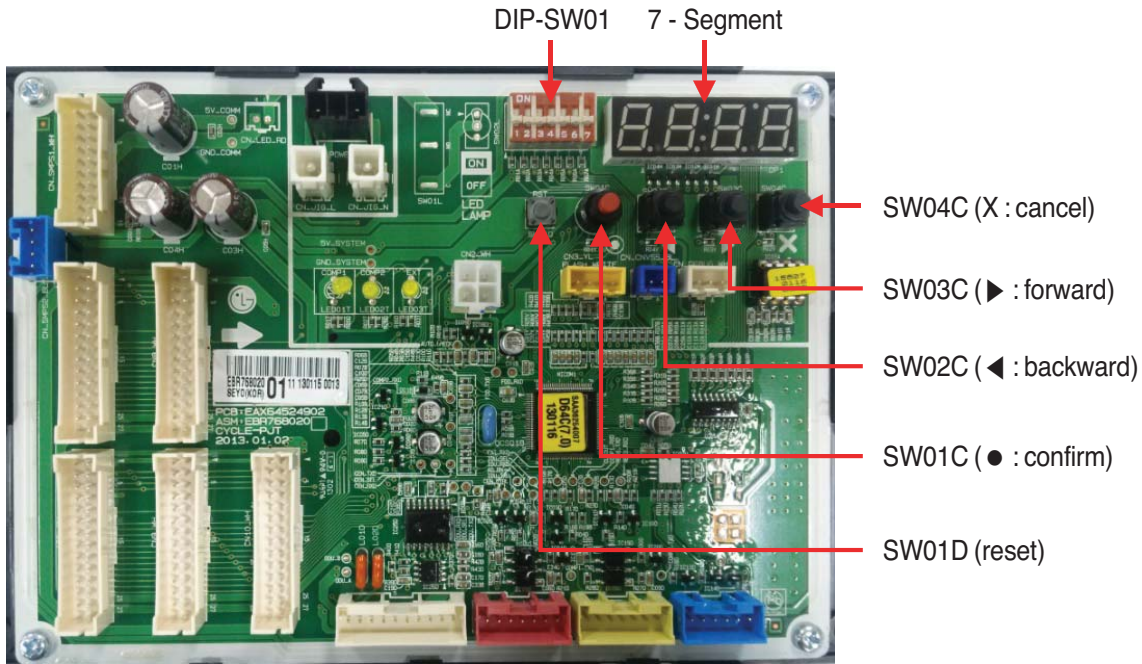

## 4. Checking the setting of outdoor units

### ■ Checking according to dip switch setting

1. You can check the setting values of the Master outdoor unit from the 7 segment LED.  
The dip switch setting should be changed when the power is OFF.
2. It checks whether the input is properly performed without the bad contact of the dip switch or not

### ■ Checking the setting of outdoor units

#### Checking according to dip switch setting

- You can check the setting values of the Master outdoor unit from the 7 segment LED.  
The dip switch setting should be changed when the power is OFF.

#### Checking the initial display

The number is sequentially appeared at the 7 segment in 5 seconds after applying the power. This number represents the setting condition. (For example, represents R410A 36HP)

#### • Initial display order

Order	No	Mean
①	8~20	Master model capacity
②	10~20	Slave 1 model capacity
③	10~20	Slave 2 model capacity
④	10~20	Slave 3 model capacity
⑤	8~80	Total capacity
⑥	1	Cooling Only
	2	Heat Pump
	3	Heat Recovery
⑦	38	380V model
	46	460V model
	22	220V model
⑧	1	LTE4

#### • Example) ARUB620LTE4

①	②	③	④	⑤	⑥	⑦	⑧
18	16	14	14	62	3	38	1

#### • Master Unit

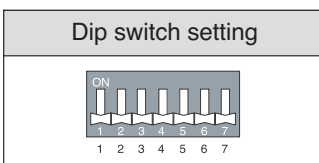

#### • Slave Unit

Dip switch setting	ODU Setting
	Slave 1
	Slave 2
	Slave 3

# **Part 5**

## **Trouble shooting guide**

# Trouble shooting guide

<b>1. The phenomena from main component failure .....</b>	<b>79</b>
<b>2. Checking Method for Key Components .....</b>	<b>80</b>
<b>2.1 Compressor .....</b>	<b>80</b>
<b>2.2 Fan Motor .....</b>	<b>81</b>
<b>2.3 Electronic Expansion Valve.....</b>	<b>82</b>
<b>2.4 Phase Bridge Diode Checking Method .....</b>	<b>85</b>
<b>2.5 Inverter IPM Checking Method .....</b>	<b>86</b>
<b>2.6 Fan IPM Checking Method(UX3 chassis) .....</b>	<b>87</b>
<b>2.7 Fan IPM Checking Method(UX2 chassis) .....</b>	<b>88</b>
<b>2.8 Pressure Sensor(High/Low Pressure Sensor) .....</b>	<b>89</b>
<b>2.9 Outdoor Fan .....</b>	<b>89</b>
<b>2.10 Solenoid Valve .....</b>	<b>90</b>
<b>2.11 Reverse Valve.....</b>	<b>91</b>
<b>2.12 Temperature Sensor .....</b>	<b>91</b>
<b>2.13 Others .....</b>	<b>92</b>
<b>3. Self-diagnosis function .....</b>	<b>93</b>
<b>4. Trouble shooting guide .....</b>	<b>104</b>

# 1. The phenomena from main component failure

## The phenomena from main component failure

Component	Phenomenon	Cause	Check method and Trouble shooting
<b>Compressor</b>	Not operating	Motor insulation broken	Check resistance between terminals and chassis
		Strainer clogged	Change strainer
		Oil leakage	Check Oil level after opening oil port
	Stop during running	Motor insulation failure	Check resistance between terminals and chassis
	Abnormal noise during running	R(L1)-S(L2)-T(L3) mis-connection	Check compressor R(L1)-S(L2)-T(L3) connection
<b>Outdoor fan</b>	High pressure error in cooling mode operation	Motor failure, bad ventilation around outdoor heat exchanger	Check the fan operation to confirm proper motor functioning. Switch OFF the outdoor unit and remove obstacles, if any, around the HEX. Check connector
<b>Outdoor EEV</b>	Heating failure, frequent defrosting	Bad connector contact	Check resistance between terminals
	No operation sound after switching ON the power supply	Coil failure	Service necessary
	Heating failure, frozen outdoor heat exchanger part	EEV clogged	Service necessary
	Low pressure error or discharge temperature error	EEV clogged	

When system fault occurs, the error code is displayed on the indoor unit display or remote control display. The trouble shooting guide is available in the service manual.

- When CH05/53/11 ERROR occurs, check if auto-addressing has done and communication wiring is ok.

## 2. Checking Method for Key Components

### 2.1 Compressor

Check and ensure in following order when error related with the compressor or error related with power occurs during operation:

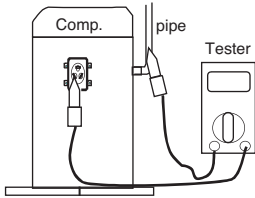
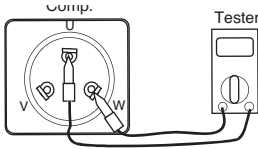
No.	Checking Item	Symptom	Countermeasure								
1	Is how long power on during operation?	1) Power on for 12 hours or more	* Go to No.2.								
		2) Power on for 12 hours or less	* Go to No.2 after applying power for designated time (12 hours).								
2	Does failure appears again when starting operation?  Method to measure insulation resistance  Figure 1.  Method to measure coil resistance  Figure 2.	1) The compressor stops and same error appears again.	* Check IPM may fail.								
		2) If output voltage of the inverter is stably output. *1	* Check coil resistor and insulation resistor. If normal, restart the unit. If same symptom occurs, replace the compressor. * Insulation resistor : 50MΩ or more * Coil resistor (below table) JQA048MBA <table border="1"> <thead> <tr> <th>Temp.</th> <th>75°C</th> </tr> </thead> <tbody> <tr> <td>U-V</td> <td>0.212 ±7% Ω (25°C(77°F))</td> </tr> <tr> <td>V-W</td> <td>0.212 ±7% Ω (25°C(77°F))</td> </tr> <tr> <td>W-U</td> <td>0.212 ±7% Ω (25°C(77°F))</td> </tr> </tbody> </table>	Temp.	75°C	U-V	0.212 ±7% Ω (25°C(77°F))	V-W	0.212 ±7% Ω (25°C(77°F))	W-U	0.212 ±7% Ω (25°C(77°F))
		Temp.	75°C								
U-V	0.212 ±7% Ω (25°C(77°F))										
V-W	0.212 ±7% Ω (25°C(77°F))										
W-U	0.212 ±7% Ω (25°C(77°F))										
3) If output voltage of the inverter is unstable or it is 0V. (When incapable of using a digital tester)	* Check the IPM. If the IPM is normal, replace the inverter board. * Check coil resistor and insulation resistor.										

#### [Cautions when measuring voltage and current of inverter power circuit]

Measuring values may differ depending on measuring tools and measuring circuits since voltage, current in the power supply or output side of the inverter has no sine waveform.

Especially, output voltage changes when output voltage of the inverter has a pattern of pulse wave.

In addition, measuring values appear largely differently depending on measuring tools.

- 1) If using a movable tester when checking that output voltage of the inverter is constant (when comparing relative voltage between lines), always use an analog tester. Especially exercise particular caution if the output frequency of the inverter is low, when using a movable tester, where change of measured voltage values is large between other lines, when virtually same values appear actually or where there is danger to determine that failure of the inverter occurred.
- 2) You can use rectification voltmeter (→+) if using commercial frequency tester when measuring output values of the inverter (when measuring absolute values). Accurate measuring values cannot be obtained with a general movable tester (For analog and digital mode).

## 2.2 Fan Motor

Checking Item	Symptom	Countermeasure
(1) The fan motor does not operate. Does failure appears again when starting operation?  (2) Vibration of the fan motor is large.	1) When power supply is abnormal	* Modify connection status in front of or at the rear of the breaker, or if the power terminal console is at frosting condition.  * Modify the power supply voltage is beyond specified scope.
	2) For wrong wiring	* For following wiring. 1. Check connection status. 2. Check contact of the connector. 3. Check that parts are firmly secured by tightening screws. 4. Check connection of polarity. 5. Check short circuit and grounding.
	3) For failure of motor	* Measure winding resistance of the motor coils. 28.5Ω ±7 %(@25°C(77°F))
	4) For defective fuse 5) For failure of circuit board	* Replace the fuse if there is defect (Fuse 800V 30A). Replace the circuit board in following procedures if problems occur again when powering on and if there are no matters equivalent to items as specified in above 1) through 4). (Carefully check both connector and grounding wires when replacing the circuit board.) 1. Replace only fan control boards. If starting is done, it means that the fan control board has defect. 2. Replace both fan control board and the main board. If starting is done, it means that the main board has defect. 3. If problems continue to occur even after countermeasure of No.1 and No.2, it means that both boards has defect.

## 2.3 Electronic Expansion Valve

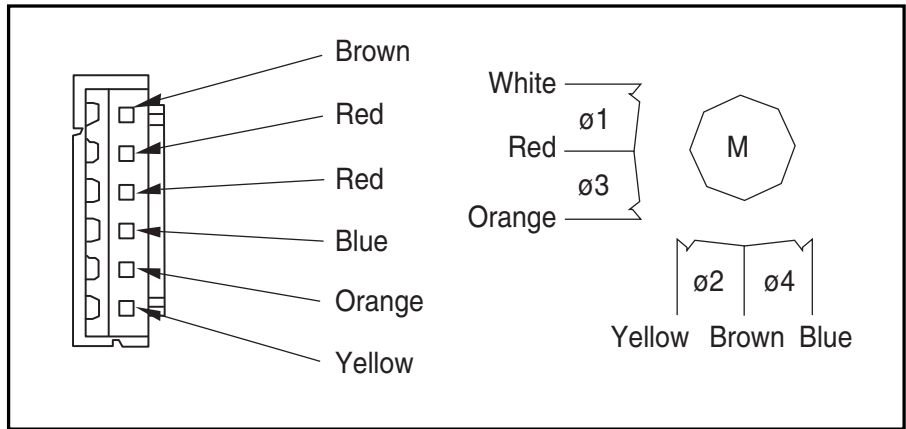

### • Pulse signal output value and valve operation

Output(ø) No.	Output state			
	1	2	3	4
ø1	ON	ON	OFF	ON
ø2	ON	ON	ON	OFF
ø3	OFF	OFF	ON	OFF
ø4	OFF	OFF	OFF	ON

### • Output pulse sequence

- In valve close state: 4 → 3 → 2 → 1 → 4
- In valve open state: 1 → 2 → 3 → 4 → 1

- \* 1. If EEV open angle does not change, all of output phase will be OFF
- 2. If output phase is different or continuously in the ON state, motor will not operate smoothly and start vibrating.

### • EEV valve operation

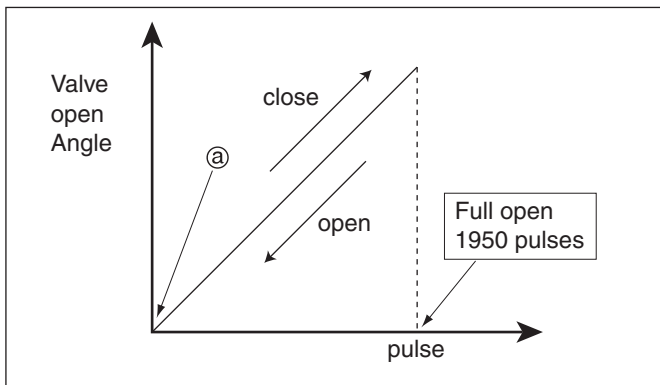

- At power ON, open angle signal of 1400 pulses output and valve position is set to @  
If valve operates smoothly, no noise and vibration occurs and if valve is closed. noise occurs.
- Noise from EEV can be confirmed by touching the EEV surface with a screw driver and listening the EEV noise.
- If liquid refrigerant is in EEV, the noise is lower.

• EEV Coil and body(Outdoor unit)

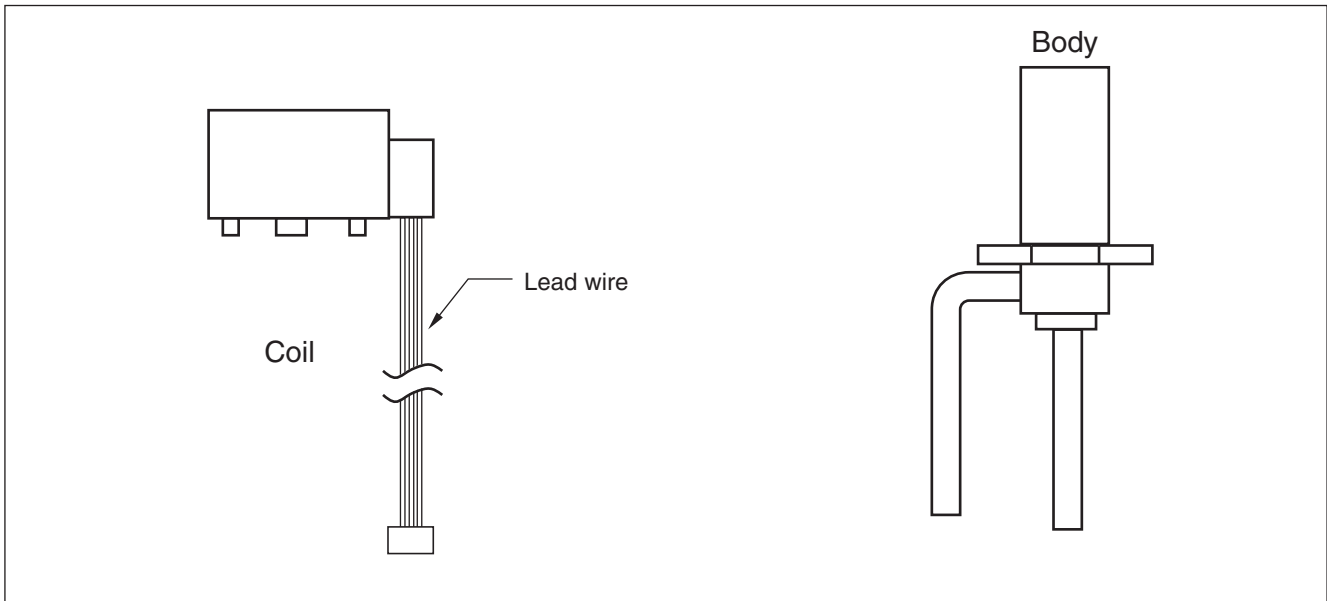

• Remove and assemble the coil

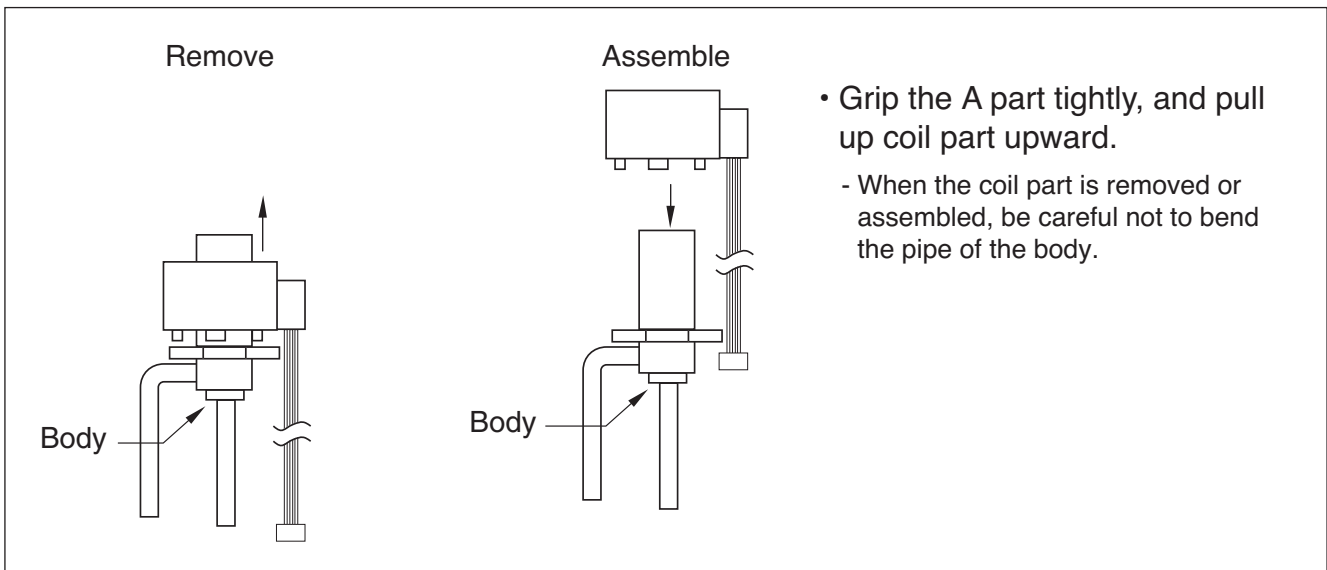

• EEV failure check method

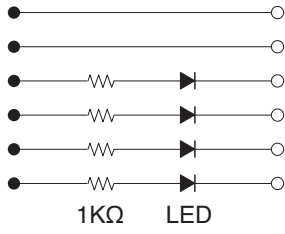
Failure mode	Diagnosis	Repair process	Unit
Microcomputer Driving circuit failure	<p>1. Disconnect the EEV connector form control board and connect testing LED</p>  <p>2. Main power ON, pulse signal is out from EEV for 17 sec. If LEDs do not turn on, or are in on state continuously, then driving circuit is abnormal</p>	Check and replace Indoor unit control board	Indoor unit
EEV locking	1. If EEV is locked, in no load state, the driving motor rotate, and clicking sound always occurs	Replace EEV	Indoor / Outdoor unit
EEV Motor coil short or misconnection	<p>1. Check the resistance between coil terminal (red-white, red-yellow, red-orange, red-blue)</p> <p>2. If the estimated resistance value is in 52 3 then the EEV is normal</p>	Replace EEV	Outdoor unit
	<p>1. Check the resistance between coil terminal (brown-white, brown-yellow, brown-orange, brown-blue)</p> <p>2. If the estimated resistance value is in 150 10 then the EEV is normal</p>	Replace EEV	Indoor unit
Full closing (valve leakage)	<p>1. Operate indoor unit with FAN mode and operate another indoor unit with COOLING mode</p> <p>2. Check indoor unit(FAN mode) liquid pipe temperature (from operation monitor of outdoor unit control board)</p> <p>3. When fan rotate and EEV is fully closed, if there is any leakage, then the temperature is down</p> <p>If estimated temperature is very low in comparison with suction temperature which is displayed at remote controller then the valve is not fully closed</p>	If the amount of leakage is much, Replace EEV	Indoor unit

## 2.4 Phase Bridge Diode Checking Method

Internal circuit diagram

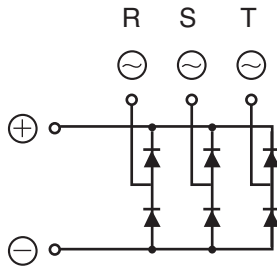

Appearance

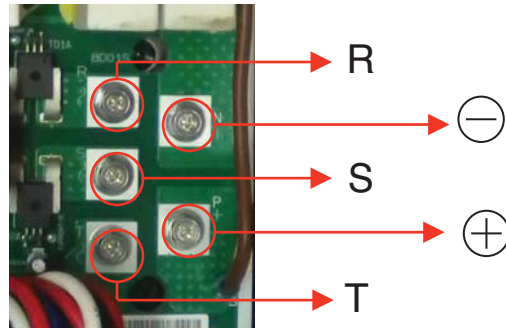

1. Wait until Comp PCB DC voltage gets discharged, after the main power switch off.
2. Pull out DC\_Link connector, CN COIL 1, 2 connector connected with Converter PCB.
3. Set multi tester in diode mode.
4. Measured value should be 0.4~0.7V measuring as below table.
5. In case the measured value is different from the table, set multi tester to resistance mode and measure. If the value is small (0 Ω) or high (hundreds M Ω), PCB needs to be replaced.
6. In case that bridge diode is damaged, check if Comp, Converter PCB assembly(IPM) is needed to be replaced.

Diode terminal Tester terminal	+ terminal: black(-)	- terminal: red(+)
R(~) : red(+)	0.4 V ~ 0.7 V	-
S(~) : red(+)	0.4 V ~ 0.7 V	-
T(~) : red(+)	0.4 V ~ 0.7 V	-
R(~) : black(-)	-	0.4 V ~ 0.7 V
S(~) : black(-)	-	0.4 V ~ 0.7 V
T(~) : black(-)	-	0.4 V ~ 0.7 V

\* Red(+) and black(-) are the measuring terminals of multi tester.



### CAUTION

- Check the electric parts of c/box, 10 minutes after switching off the main supply and checking DC voltage is discharged. Otherwise, there is chance of getting electric shock.
- There is chance of electric shock by charged voltage.

## 2.5 Inverter IPM/IGBT Checking Method

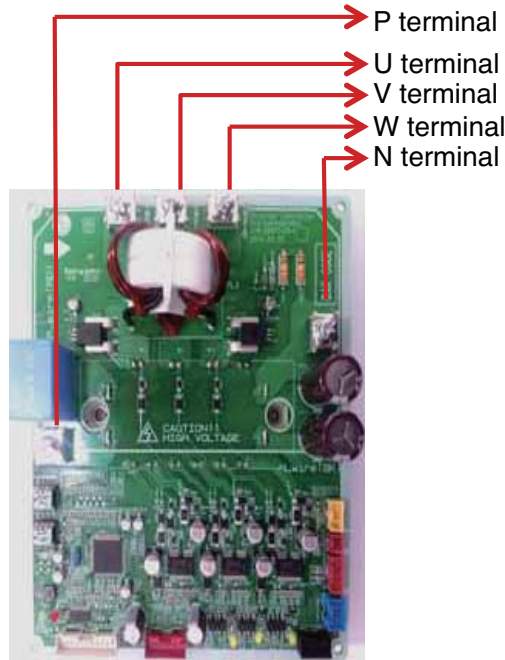

1. Wait until Comp PCB DC voltage is discharged after main power off.
2. Pull out DC\_Link connector and U,V,W COMP connector connected with fan Comp PCB
3. Set multi tester to resistance mode.
4. If the value between P and N terminal of IPM is short(0Ω) or open(hundreds MΩ), PCB needs to be replaced.(IPM damaged)
5. In the measured value with resistance mode should be within 2.3K Ω ±10%(25°C(77°F)).
6. In case measured value is different from the table, PCB needs to be replaced.(PCB damaged).

	<b>P terminal : black (-)</b>	<b>N terminal : red (-)</b>
U terminal : red(+)	2.3K Ω ± 10%(25°C(77°F))	3.0K Ω ± 10%(25°C(77°F))
V terminal : red(+)	2.3K Ω ± 10%(25°C(77°F))	3.0K Ω ± 10%(25°C(77°F))
W terminal : red(+)	2.3K Ω ± 10%(25°C(77°F))	3.0K Ω ± 10%(25°C(77°F))
	<b>P terminal : red(+)</b>	<b>N terminal : red (+)</b>
U terminal : black(-)	3.0K Ω ± 10%(25°C(77°F))	2.3K Ω ± 10%(25°C(77°F))
V terminal : black(-)	3.0K Ω ± 10%(25°C(77°F))	2.3K Ω ± 10%(25°C(77°F))
W terminal : black(-)	3.0K Ω ± 10%(25°C(77°F))	2.3K Ω ± 10%(25°C(77°F))

\* Red(+) and black(-) are the measuring terminals of multi tester.

## 2.6 Fan IPM Checking Method

1. Wait until inverter PCB DC voltage gets discharged after the main power switch off.
2. Pull out DC Connector and U,V,W fan motor connector connected with fan PCB.
3. Set multi tester in diode mode.
4. Measured value should be 0.4~0.7V measuring as below table.
5. In case the measured value is different from the table, set multi tester to resistance mode and measure.  
If the value is small (0Ω) or high (hundreds MΩ), PCB needs to be replaced.
6. In case measured value is different from the table, PCB needs to be replaced (PCB damaged).

	P Terminal : Black (-)	N Terminal : Black (-)
<b>U Terminal : Red (+)</b>	0.4V ~ 0.7V	Open
<b>V Terminal : Red (+)</b>	0.4V ~ 0.7V	Open
<b>W Terminal : Red (+)</b>	0.4V ~ 0.7V	Open
	P Terminal : Red (+)	N Terminal : Red (+)
<b>U Terminal : Black (-)</b>	Open	0.4V ~ 0.7V
<b>V Terminal : Black (-)</b>	Open	0.4V ~ 0.7V
<b>W Terminal : Black (-)</b>	Open	0.4V ~ 0.7V

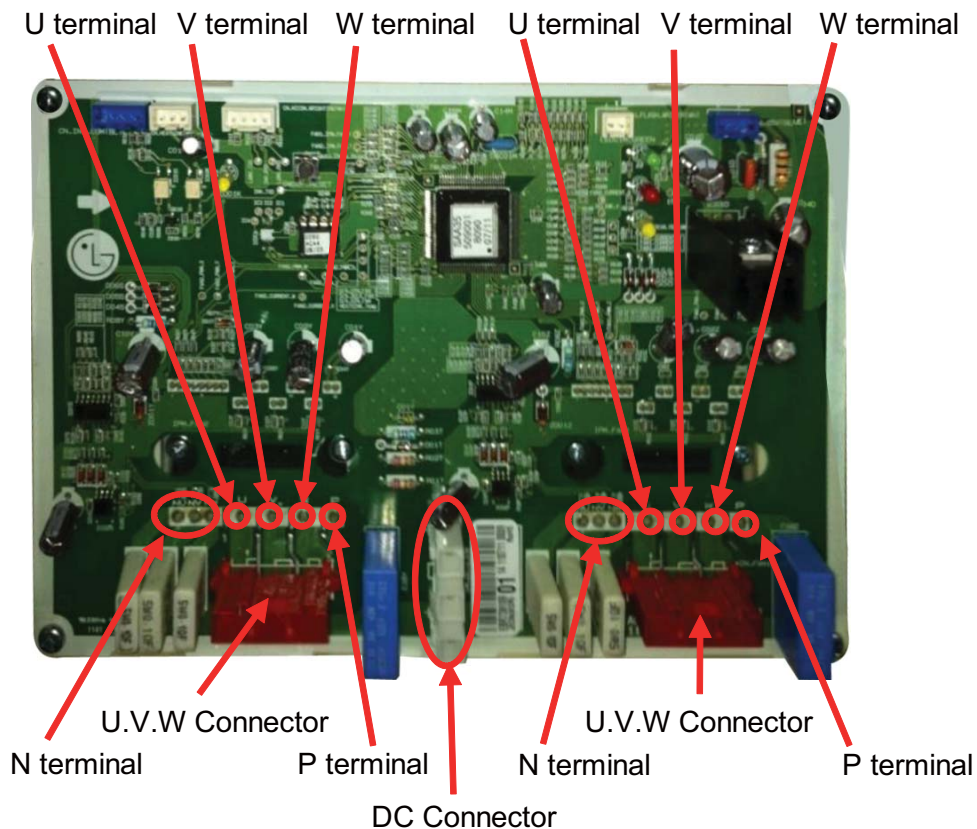

## 2.7 Fan IPM Checking Method

1. Wait until inverter PCB DC voltage gets discharged after the main power switch off.
2. Pull out DC Connector and U,V,W fan motor connector connected with fan PCB.
3. Set multi tester in diode mode.
4. Measured value should be 0.4~0.7V measuring as below table.
5. In case the measured value is different from the table, set multi tester to resistance mode and measure.  
If the value is small (0Ω) or high (hundreds MΩ), PCB needs to be replaced.
6. In case measured value is different from the table, PCB needs to be replaced (PCB damaged).

	P Terminal : Black (-)	N Terminal : Black (-)
U Terminal : Red (+)	0.4V ~ 0.7V	Open
V Terminal : Red (+)	0.4V ~ 0.7V	Open
W Terminal : Red (+)	0.4V ~ 0.7V	Open
	P Terminal : Red (+)	N Terminal : Red (+)
U Terminal : Black (-)	Open	0.4V ~ 0.7V
V Terminal : Black (-)	Open	0.4V ~ 0.7V
W Terminal : Black (-)	Open	0.4V ~ 0.7V

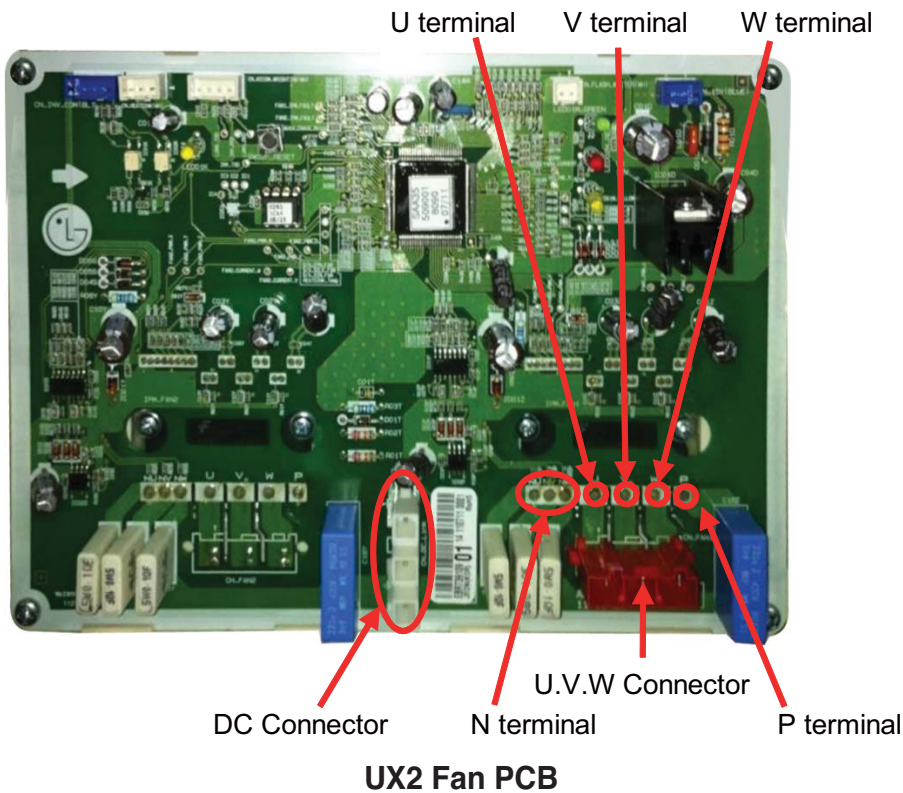

## 2.8 Pressure Sensor(High/Low Pressure Sensor)

Connect manifold gauge to the service valve of outdoor unit, and compare the output of high pressure sensor to the output of low pressure sensor to detect the defect.

below) Compare the output of pressure sensor to the output of manifold gauge pressure using the table below. Read the pressure clearly between black and white as the composition of pressure sensor.

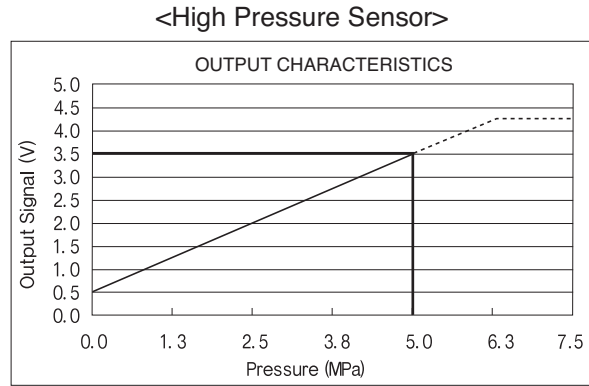
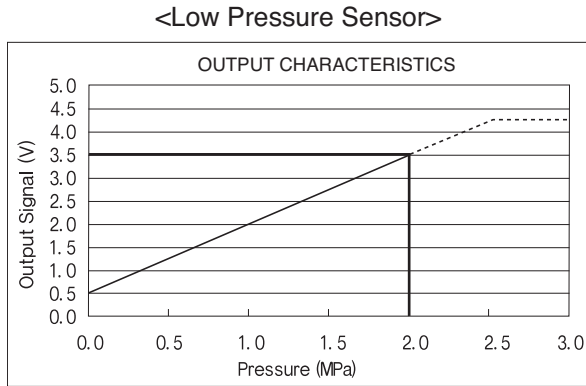

- 1) If the pressure of manifold gauge is 0~1kg/cm<sup>2</sup>, it indicates the pressure got lower due to the leakage of refrigerant. Find the place of leakage and fix it.
- 2) If the difference of the outputs of high and low pressure is in the range of 1kg/cm<sup>2</sup>, the pressure sensor is normal.
- 3) If the difference of the outputs of high and low pressure is over 1kg/cm<sup>2</sup>, the pressure sensor is out of order, it need to be replaced.
- 4) The composition of pressure sensor

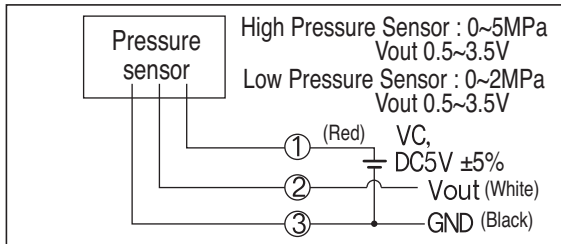

The pressure sensor is composed like the circuit picture shown above. If DC 5V voltage flows on red and black wire, voltage would be made between the white and black wire. The pressure which is equivalent to the pressure output is shown in the table above.

## 2.9 Outdoor Fan

- 1) The outdoor fan is controlled by the inverter motor which can control the number of rotations.
- 2) The outdoor fan is controlled by the high/low pressure of the outdoor unit after the operation of compressor.
- 3) There is possibility that the outdoor fan does not operate due to low capacity operation or low outdoor temperature even if the compressor is operating. This does not mean breakdown of the unit, the fan will start operating if it reaches the set point.

## 2.10 Solenoid Valve

Check the conformity of the operation of solenoid valve to the output signal of control board.

### 1) Oil solenoid valve

1. It is located in the bottom of accumulator, and it starts operating after some period of time of the compressor operation to provide oil stored in the bottom of the accumulator to the compressor.
2. When the compressor starts operating, oil solenoid valve will be on for 2 minutes. Check if there is operation noise or piping vibration on the solenoid valve.
3. It turns on right after the compressor stop operating.
4. Solenoid valve can turn on and off repeatedly by the condition of cycle operation; this does not indicate the breakdown of the unit.
5. Insulation resistance in the state of connecting the valve to coil should be over 100m $\Omega$  when measure it with DC mega tester(DC 500V).

### 2) Partial defrosting solenoid valve

1. Defrost operation eliminates ice attached on heat exchanger, recovering performance of heat exchanger.
2. Two solenoid valves will be on by turns in the extent of 6 minutes when separated defrosting is on.
3. It will be turned off right after the end of separated defrosting.
4. The change of the operation condition by the operation of solenoid valve can be checked by the before and behind temperature of bypass piping and the sound of refrigerant.
5. Insulation resistance in the state of connecting the valve to coil should be over 100m $\Omega$  when measure it with DC mega tester(DC 500V).

## 2.11 Reverse Valve

1. Keep it off before the outdoor unit is powered on and the indoor unit is turned on.
2. Cooling, defrosting, oil recovery : OFF, heating : ON
3. When alternating cooling to heating, transform 4 way valve during re-starting for 3 minutes.
4. To check the mode of cooling/heating operation of 4 way valve, touch the piping surface of low pressure service valve.
5. Refrigerant flowchart of 4 way valve

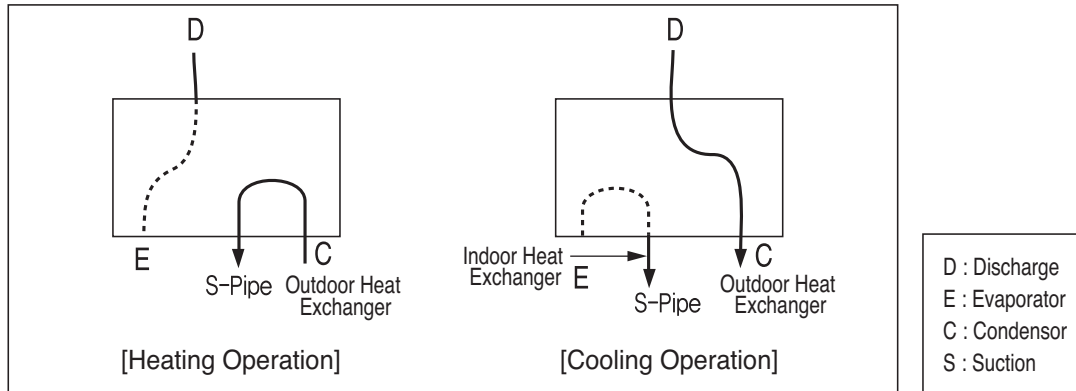

6. Insulation resistance in the state of connecting the valve to coil should be over 100mΩ when measure it with DC mega tester(DC 500V).

## 2.12 Temperature Sensor

- 1) outdoor temperature sensor : TH1
- 2) Pipe temperature sensor : TH2
- 3) Discharge pipe(D-pipe) temperature sensor : TH3
  1. Check the condition of installation and the contact of temperature sensor.
  2. Check whether the connector contact of temperature sensor is normal.
  3. Measure the resistance of temperature sensor.

	TH1	TH2	TH3
Resistance	10KΩ±1%(25°C(77°F))	5KΩ±1%(25°C(77°F))	200KΩ±1%(25°C(77°F))
	1.07KΩ±3.3%(85°C(185°F))	535KΩ±3.3%(85°C(185°F))	28KΩ±7.7%(85°C(185°F))

## 2.13 Others

### **Electrolytic capacitor and resistor for voltage distribution**

- 1) Disconnect an terminal of voltage distribution resistor from each DC link electrolytic capacitor
- 2) Set the multi meter to resistance mode, connect the probe to +,- terminal of the capacitor. If the estimated resistance value is increase continuously without short(value is 0), then the resistor is normal
- 3) Set the multi meter to resistance mode, confirm that the resistance value of the resistor is around 270 kOhm



*Check and replace inferior components*

## 3. Self-diagnosis function

### Error Indicator

- This function indicates types of failure in self-diagnosis and occurrence of failure for air condition.
- Error mark is displayed on display window of indoor units and wired remote controller, and 7-segment LED of outdoor unit control board as shown in the table.
- If more than two troubles occur simultaneously, lower number of error code is first displayed.
- After error occurrence, if error is released, error LED is also released simultaneously.

### Error Display

- 1st,2nd,3rd LED of 7-segment indicates error number, 4th LED indicates unit number.

- Ex) 211 : No.21 error of master unit  
 213 : No.21 error of slave2  
 1051 : No.105 error of master unit

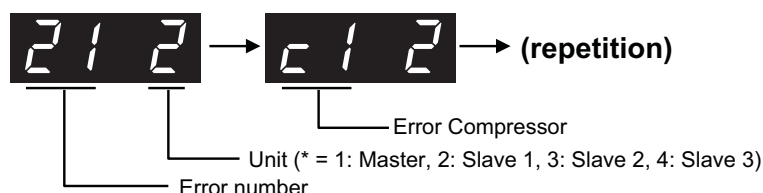

\* Refer to the DX-Ventilation manual for DX-Ventilation error code

Display			Title	Cause of Error	
Indoor unit related error	0	1	-	Air temperature sensor of indoor unit	Air temperature sensor of indoor unit is open or short
	0	2	-	Inlet pipe temperature sensor of indoor unit	Inlet pipe temperature sensor of indoor unit is open or short
	0	3	-	Communication error : wired remote controller ↔ indoor unit	Failing to receive wired remote controller signal in indoor unit PCB
	0	4	-	Drain pump	Malfunction of drain pump
	0	5	-	Communication error : outdoor unit ↔ indoor unit	Failing to receive outdoor unit signal in indoor unit PCB
	0	6	-	Outlet pipe temperature sensor of indoor unit	Outlet pipe temperature sensor of indoor unit is open or short
	0	9	-	Indoor EEPROM Error	In case when the serial number marked on EEPROM of Indoor unit is 0 or FFFFFFFF
	1	0	-	Poor fan motor operation	Disconnecting the fan motor connector / Failure of indoor fan motor lock
	1	7	-	Inlet Air temperature sensor of FAU	Air temperature sensor of indoor unit is open or short
	Outdoor unit related error	2	1	*	Master Outdoor Unit Inverter Compressor IPM Fault
2		2	*	Inverter Board Input Over Current(RMS) of Master Outdoor Unit	Master Outdoor Unit Inverter Board Input Current excess (RMS)
2		3	*	Master Outdoor Unit Inverter Compressor DC link Low Voltage	DC charging is not performed at Master Outdoor Unit after starting relay turn on.
2		4	*	Master Outdoor Unit High Pressure Switch	System is turned off by Master Outdoor Unit high pressure switch.
2		5	*	Master Outdoor Unit Input Voltage High/ Low Voltage	Master Outdoor Unit input voltage is over 487V or below 270V
2		6	*	Master Outdoor Unit Inverter Compressor Start Failure	The First Start Failure by Master Outdoor Unit Inverter Compressor Abnormality
2		9	*	Master Outdoor Unit Inverter Compressor Over Current	Master Outdoor Unit Inverter Compressor Fault OR Drive Fault
3		2	*	Master Outdoor Unit Inverter Compressor1 High Discharge Temperature	Master Outdoor Unit Inverter Compressor1 High Discharge Temperature
3		3	*	Master Outdoor Unit Inverter Compressor2 High Discharge Temperature	Master Outdoor Unit Inverter Compressor2 High Discharge Temperature
3		4	*	High Pressure of Master Outdoor Unit	High Pressure of Master Outdoor Unit

## Self-diagnosis function

Display			Title	Cause of Error	
Outdoor unit related error	3	5	*	Low Pressure of Master Outdoor Unit	Low Pressure of Master Outdoor Unit
	3	6	*	Master Outdoor Unit Low Compression Ratio Limited	Master Outdoor Unit Low Compression Ratio Limited
	4	0	*	Master Outdoor Unit Inverter Compressor CT Sensor Fault	Master Outdoor Unit Inverter Compressor CT Sensor open or short
	4	1	*	Master Outdoor Unit Inverter Compressor1 Discharge Temperature Sensor Fault	Master Outdoor Unit Inverter Compressor Discharge Temperature Sensor open or short
	4	2	*	Master Outdoor Unit Low Pressure Sensor Fault	Master Outdoor Unit Low Pressure Sensor open or short
	4	3	*	Master Outdoor Unit High Pressure Sensor Fault	Master Outdoor Unit High Pressure Sensor open or short
	4	4	*	Master Outdoor Unit Air Temperature Sensor Fault	Master Outdoor Unit Air Temperature Sensor open or short
	4	5	*	Master Outdoor Unit Heat Exchanger Temperature Sensor (Front side) Fault	Master Outdoor Unit Heat Exchanger Temperature Sensor(Front side) open or short
	4	6	*	Master Outdoor Unit Suction Temperature Sensor Fault	Master Outdoor Unit Suction Temperature Sensor open or short
	4	7	*	Master Outdoor Unit Inverter Compressor2 Discharge Temperature Sensor Fault	Master Outdoor Unit Inverter Compressor2 Discharge Temperature Sensor open or short
	4	9	*	Master Outdoor Unit Faulty IPM Temperature Sensor	Master Outdoor Unit IPM Temperature Sensor short/open
	5	0	*	Omitting connection of R, S, T power of Master Outdoor Unit	Omitting connection of Master outdoor unit
	5	1	*	Excessive capacity of indoor units	Excessive connection of indoor units compared to capacity of Outdoor Unit
	5	2	*	Communication error : inverter PCB → Main PCB	Failing to receive inverter signal at main PCB of Master Outdoor Unit
	5	3	*	Communication error : indoor unit → Main PCB of Outdoor Unit	Failing to receive indoor unit signal at main PCB of Outdoor Unit .
	5	7	*	Communication error : Main PCB → inverter PCB	Failing to receive signal main PCB at inverter PCB of Master Outdoor Unit
	5	9	*	Mixing Installation of Sub Outdoor Unit	Mixing Installation of Old Sub Outdoor Unit and New Slave Outdoor Unit
	6	0	*	Inverter PCB EEPROM Error of Master Outdoor Unit	Access Error of Inverter PCB of Master Outdoor Unit
	6	2	*	Master Outdoor Unit Inverter Heatsink High Temperature	System is turned off by Master Outdoor Unit Inverter Heatsink High Temperature
	6	5	*	Master Outdoor Unit Inverter Heatsink Temperature Sensor Fault	Master Outdoor Unit Inverter Heatsink Temperature Sensor open or short
	6	7	*	Master Outdoor Unit Fan Lock	Restriction of Master Outdoor Unit
	7	1	*	Converter CT Sensor Error of Master Outdoor Unit	Converter CT Sensor open or short of Master Outdoor Unit
	7	5	*	Master Outdoor Unit Fan CT Sensor Error	Master Outdoor Unit Fan CT Sensor open or short
	7	6	*	Master Outdoor Unit Fan DC Link High Voltage Error	Master Outdoor Unit Fan DC Link High Voltage Error
	7	7	*	Master Outdoor Unit Fan Over Current Error	Master Outdoor Unit Fan Current is over 5A
	7	9	*	Master Outdoor Unit Fan Start Failure Error	Master Outdoor Unit Fan First Position Sensing Failure
	8	6	*	Master Outdoor Unit Main PCB EEPROM Error	Communication Fail Between Master Outdoor Unit Main MICOM and EEPROM or omitting EEPROM
	8	7	*	Master Outdoor Unit Fan PCB EEPROM Error	Communication Fail Between Master Outdoor Unit Fan MICOM and EEPROM or omitting EEPROM

Display				Title	Cause of Error
Outdoor unit related error	1	0	4 *	Communication Error Between Master Outdoor Unit and Other Outdoor Unit	Failing to receive Slave Unit signal at main PCB of Master Outdoor Unit
	1	0	5 *	Master Outdoor Unit Fan PCB Communication Error	Failing to receive fan signal at main PCB of Master unit.
	1	0	6 *	Master Outdoor Unit FAN IPM Fault Error	Instant Over Current at Master Outdoor Unit Fan IPM
	1	0	7 *	Master Outdoor Unit Fan DC Link Low Voltage Error	Master Outdoor Unit Fan DC Link Input Voltage is under 380V
	1	1	3 *	Master Outdoor Unit Liquid pipe Temperature Sensor Error	Liquid pipe temperature sensor of Master Outdoor Unit is open or short
	1	1	4 *	Master Outdoor Unit Subcooling Inlet Temperature Sensor Error	Master Outdoor Unit Subcooling Inlet Temperature Sensor Error
	1	1	5 *	Master Outdoor Unit Subcooling Outlet Temperature Sensor Error	Master Outdoor Unit Subcooling Outlet Temperature Sensor Error
	1	1	6 *	Master Outdoor Unit Oil Level Sensor Error	Oil Level Sensor of Master Outdoor Unit is open or short
	1	4	5 *	Master outdoor unit Main Board - External Board communication Error	Master outdoor unit Main Board - External Board communication Error
	1	5	0 *	Master Outdoor Unit Discharge Super Heat Low	Master Outdoor Unit Low Discharge Super Heat for 5 minutes
	1	5	1 *	Failure of operation mode conversion at Master Outdoor Unit	Failure of operation mode conversion at Master Outdoor Unit
	1	5	3 *	Master Outdoor Unit Heat Exchanger Temperature Sensor (upper part) Fault	Master Outdoor Unit Heat Exchanger Temperature Sensor (upper part) Fault
	1	5	4 *	Master Outdoor Unit Heat Exchanger Temperature Sensor (lower part) Fault	Master Outdoor Unit Heat Exchanger Temperature Sensor(lower part) open or short
	1	8	2 *	Master outdoor unit External Board Main-Sub Micom communication Error	Master Outdoor Unit Main Board Main-Sub Micom communication failed
	1	9	3 *	Master Outdoor Unit Fan Heatsink High Temperature	System is turned off by Master Outdoor Unit Fan Heatsink High Temperature
1	9	4 *	Master Outdoor Unit Fan Heatsink Temperature Sensor Fault	Master Outdoor Unit Fan Heatsink Temperature Sensor open or short	

## 4. Trouble Shooting Guide

Error No.	Error Type	Error Point	Main Reasons
01	Indoor unit air sensor error	Indoor unit sensor is open/short	1. Indoor unit PCB wrong connection 2. Indoor unit PCB failure 3. Sensor problem (main reason)
01(FAU)	FAU Outlet air sensor error		
02	Indoor unit pipe inlet sensor error		
06	Indoor unit pipe outlet sensor error		
17(FAU)	FAU Inlet air sensor error		

### ■ Error diagnosis and countermeasure flow chart

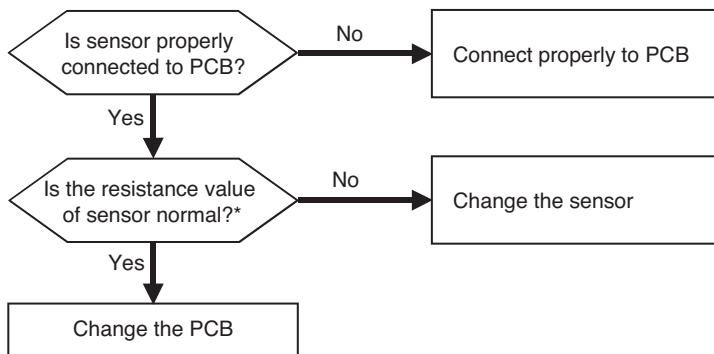

\*\* In case the value is more than 100kΩ (open) or less than 100Ω (short), Error occurs

Refer: Resistance value maybe change according to temperature of temp sensor,  
 It shows according to criteria of current temperature(±5% margin) → Normal  
 Air temp sensor: 10°C = 20.7kΩ : 25°C= 10kΩ : 50°C= 3.4kΩ  
 Pipe temp sensor: 10°C = 10kΩ : 25°C= 5kΩ : 50°C= 1.8kΩ



← CN-ROOM : Indoor air temp sensor  
 ← CN-PIPE IN : Pipe inlet temp sensor  
 ← CN-PIPE OUT : Pipe outlet temp sensor



← Measure the resistance of outlet pipe temp sensor.

Error No.	Error Type	Error Point	Main Reasons
03	No communication between cabled remote controller & indoor unit	The remote controller did not receive the signal from indoor unit during specific time	1. Remote controller fault 2. Indoor unit PCB fault 3. Connector fault, Wrong connection 4. Communication cable problem

**■ Error diagnosis and countermeasure flow chart**

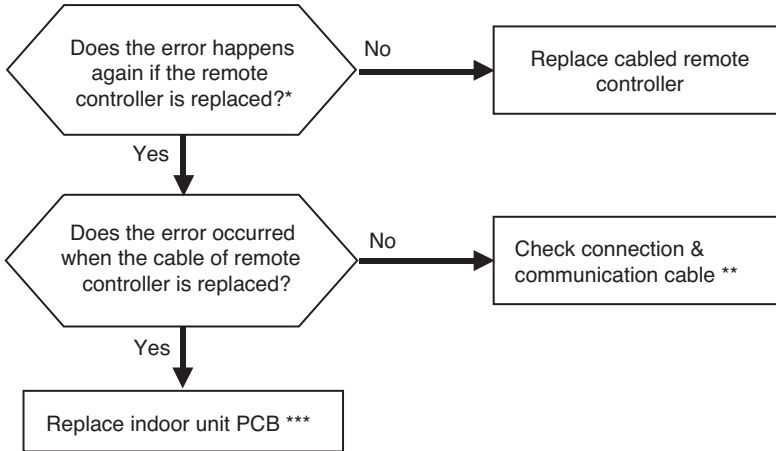

\* If there is no remote controller to replace : Use another unit's remote controller doing well

\*\* Check cable : Contact failure of connected portion or extension of cable are main cause  
 Check any surrounded noise ( check the distance with main power cable)  
 → make safe distance from the devices generate electromagnetic wave

\*\*\* After replacing indoor unit PCB, do Auto Addressing & input unit's address if connected to central controller.  
 (All the indoor units connected should be turned on before Auto Addressing)



**CN-REMO** : Remote controller connection

\* The PCB can differ from model to model. Check from the right source.



Checking communication cable connection status

## Trouble Shooting Guide

Error No.	Error Type	Error Point	Main Reasons
04	Drain pump error	Float switch is open due to rising of condensate water level because of drain pump fault or drain pipe clogging	<ol style="list-style-type: none"> <li>1. Drain pump/float switch fault</li> <li>2. Improper drain pipe location, clogging of drain pipe</li> <li>3. Indoor unit PCB fault</li> </ol>

### ■ Error diagnosis and countermeasure flow chart

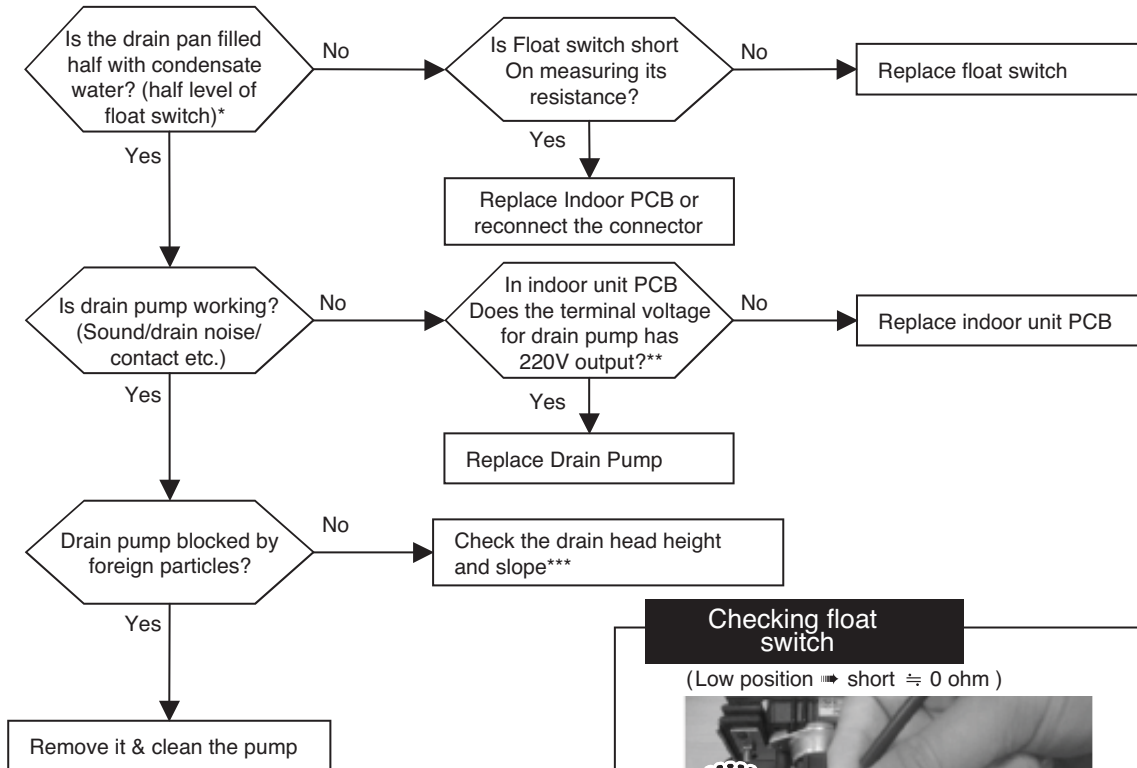

\* If the float goes up higher than a half of float switch then the circuit is open & the unit is stopped automatically.

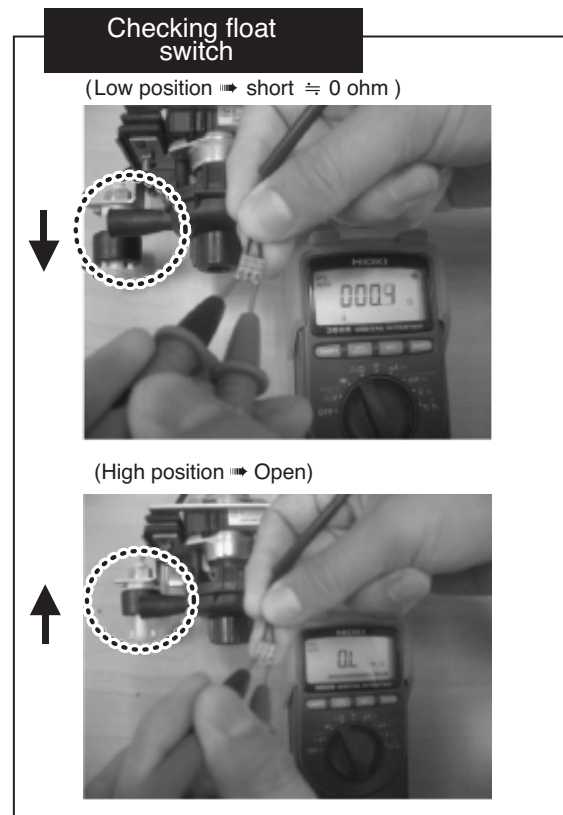
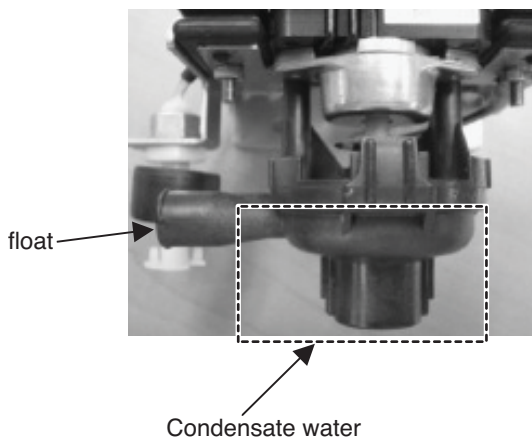

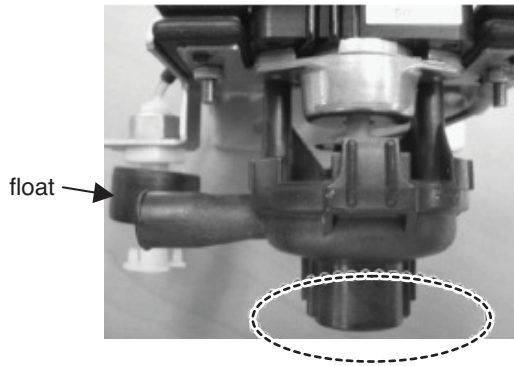

A:Point to check rotating

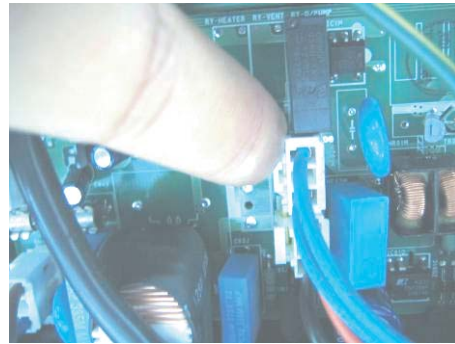

\*\*\* Indoor PCB drain pump connector  
(Check input of 220V)  
(Marked as **CN-DPUMP**)

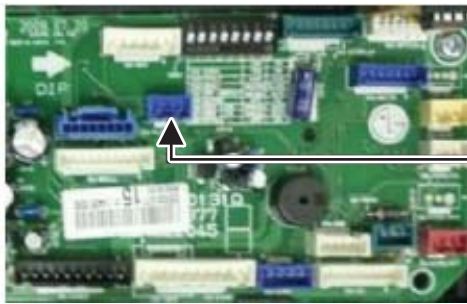

Float switch Housing (CN-FLOAT)

[\*\*\*] Standard of drain pipe head height / slope

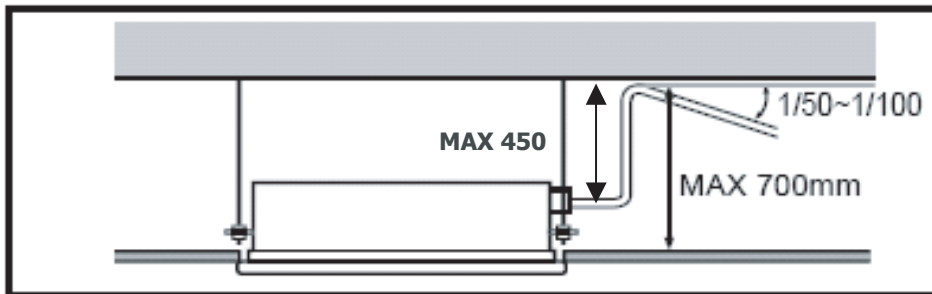

Error No.	Error Type	Error Point	Main Reasons
05	Indoor & Outdoor unit communication error	No signal communication between indoor & outdoor units.	1. Auto addressing is not done 2. Communication cable is not connected 3. Short circuit of communication cable 4. Indoor unit communication circuit fault 5. Outdoor unit communication circuit fault 6. Not enough distance between power and communication cable? 7. T phase line disconnection or N phase connected.

■ Error diagnosis and countermeasure flow chart

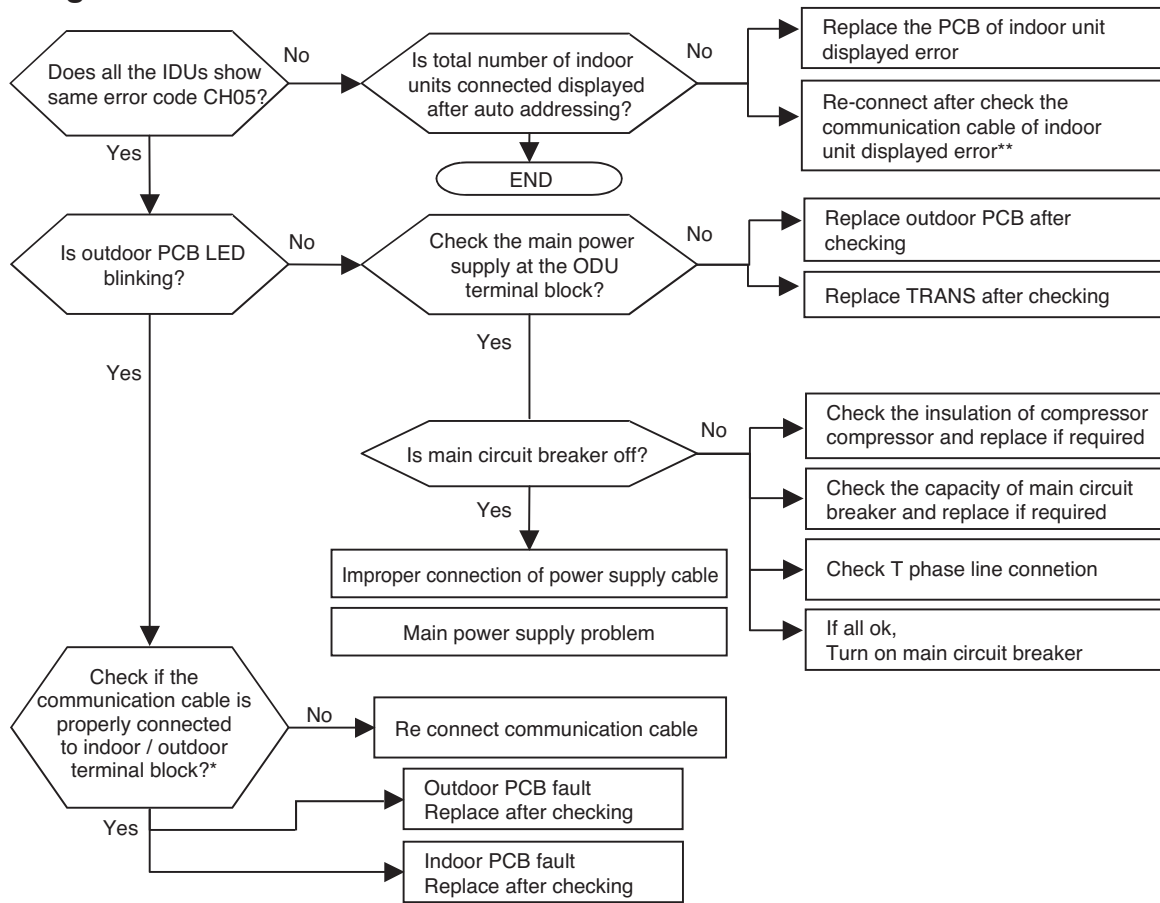

\* (Note1) communication from IDU is normal if voltage fluctuation(-9V ~ +9V) exists when checking DC voltage of communication terminal between IDU and ODU

\* If the DC voltage between communication terminal A, B of indoor unit is fluctuate within (-9V~+9V) then communication from outdoor unit is normal

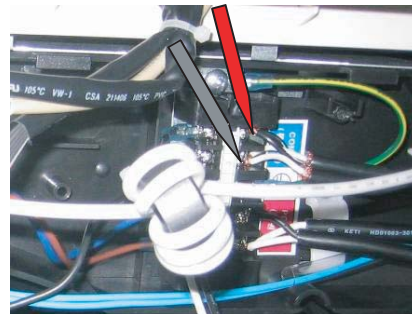

Error No.	Error Type	Error Point	Main Reasons
09	Indoor unit EEPROM error	Error occur in EEPROM of the Indoor PCB	1. Error developed in communication between the micro-processor and the EEPROM on the surface of the PCB. 2. ERROR due to the EEPROM damage

■ **Error diagnosis and countermeasure flow chart**

- Replace the indoor unit PCB, and then make sure to perform Auto addressing and input the address of central control

## Trouble Shooting Guide

Error No.	Error Type	Error Point	Main Reasons
10	Indoor unit BLDC fan motor failure	Indoor BLDC fan motor feedback signal is absent (for 50 sec.)	1. Motor connector connection fault 2. Indoor PCB fault 3. Motor fault

### ■ Error diagnosis and countermeasure flow chart

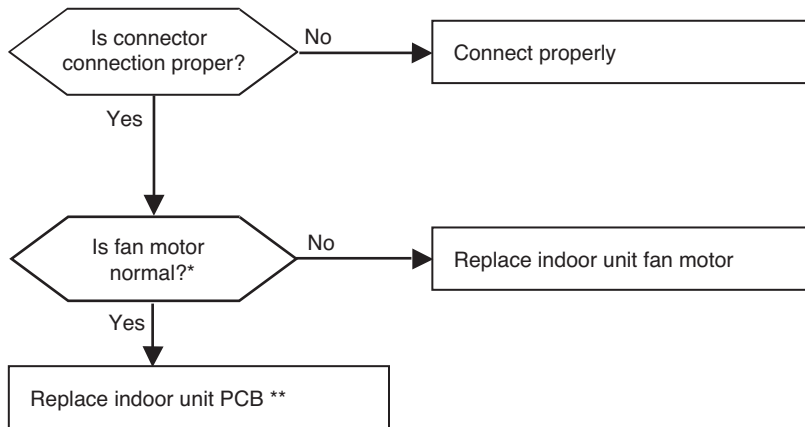

\* It is normal when check hall sensor of indoor fan motor as shown below

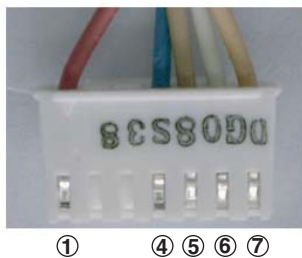

#### Each terminal with the tester

Tester		Normal resistance(±10%)	
+	-		
①	④	∞	∞
⑤	④	hundreds kΩ	hundreds kΩ
⑥	④	∞	∞
⑦	④	hundreds kΩ	hundreds kΩ

#### <Checking connection state of fan motor connector>

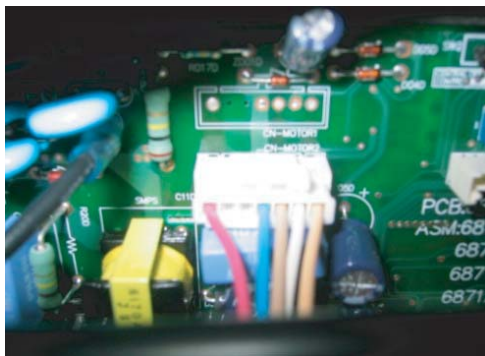

\*\* Replace the indoor unit PCB, and then make sure to do Auto addressing and input the address of central control

(Notice: The connection of motor connector to PCB should be done under no power supplying to PCB)

Error No.	Error Type	Error Point	Main Reasons
21*	Comp PCB Assy IPM Fault occur	IPM self protection circuit activation (Overcurrent/IPM overheating/Vcc low voltage)	1. Over current detection at Inverter compressor(U,V,W) 2. Compressor damaged (insulation damaged/Motor damaged) 3. IPM overheating (Heat sink disassembled) 4. Inverter compressor terminal disconnected or loose 5. Inverter PCB assembly damaged 6. ODU input current low
Master 211			
Slave1 212			
Slave2 213			
Slave3 214			

■ Error diagnosis and countermeasure flow chart

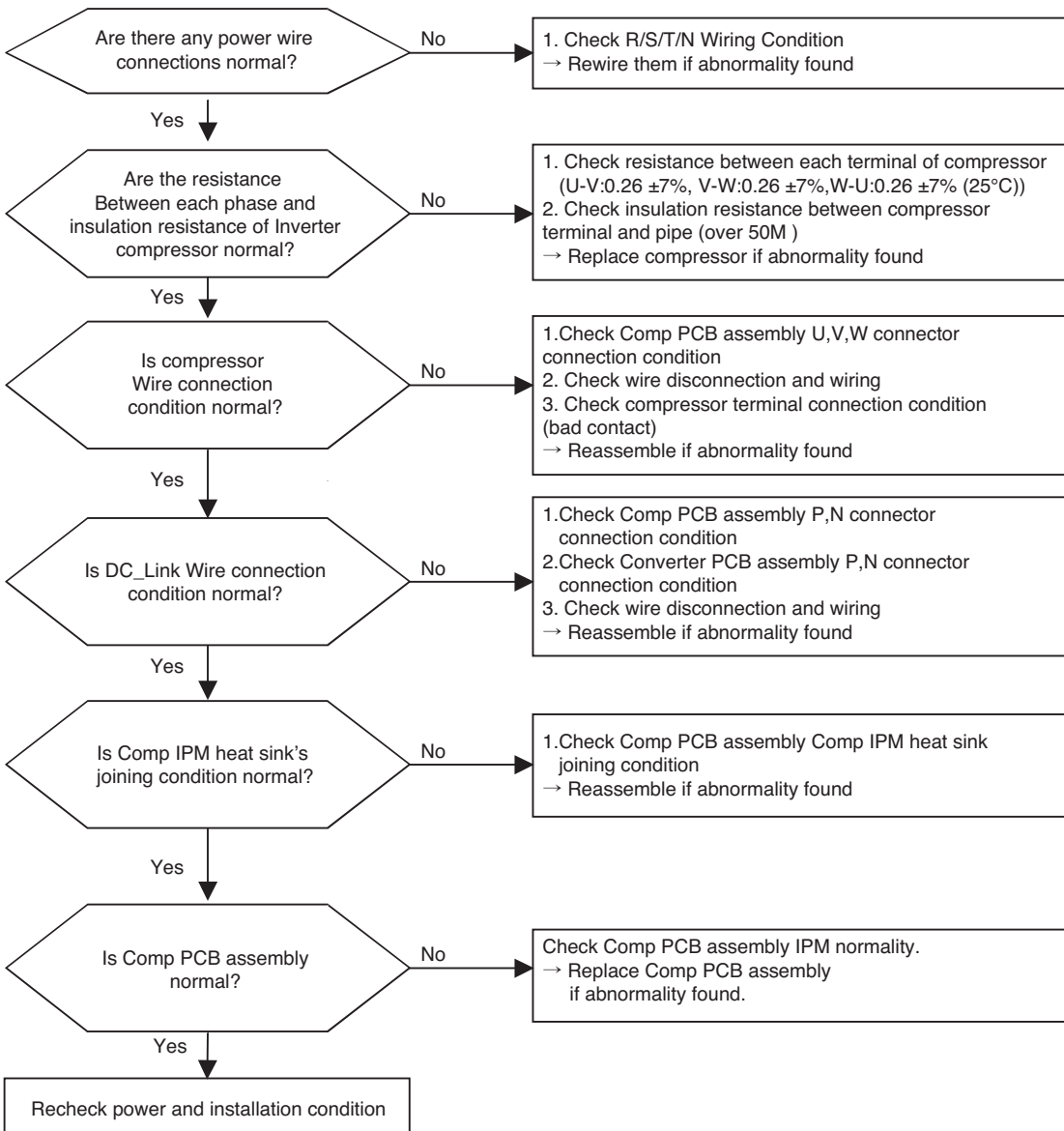

## Trouble Shooting Guide

\* Measuring resistance between each terminal of compressor



\* Compressor wire connector connection point

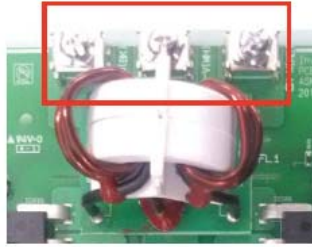

\* IPM joining point

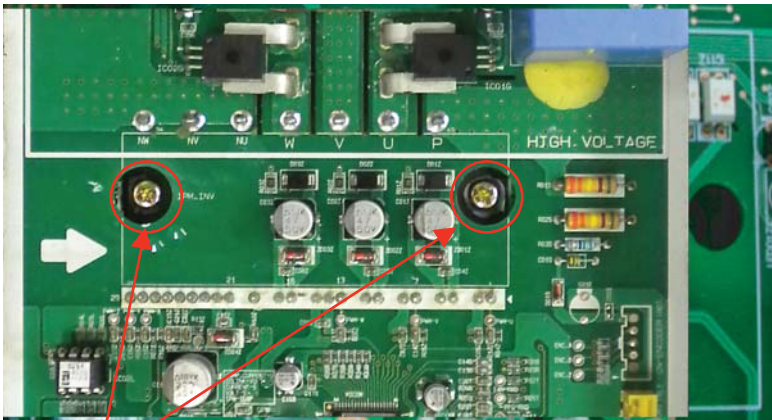

Check joining condition

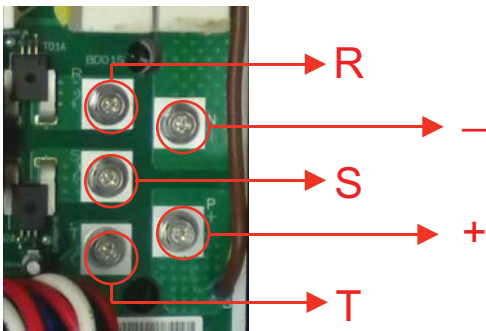

Check DC\_Link Connector joining condition

Error No.	Error Type	Error Point	Main Reasons
22* Master 221 Slave1 222 Slave2 223 Slave3 224	AC Input Current Over Error	Converter PCB Assembly input 3 phase power current is over limited value(24A)	<ol style="list-style-type: none"> <li>1. Overload operation (Pipe clogging/Covering/EEV defect/Ref. overcharge)</li> <li>2. Compressor damage(Insulation damage/Motor damage)</li> <li>3. Input voltage low</li> <li>4. Power Line Misconnection</li> <li>5. Converter PCB Assembly damage (Input current sensing part)</li> </ol>

**■ Error Diagnosis and Countermeasure Flow Chart**

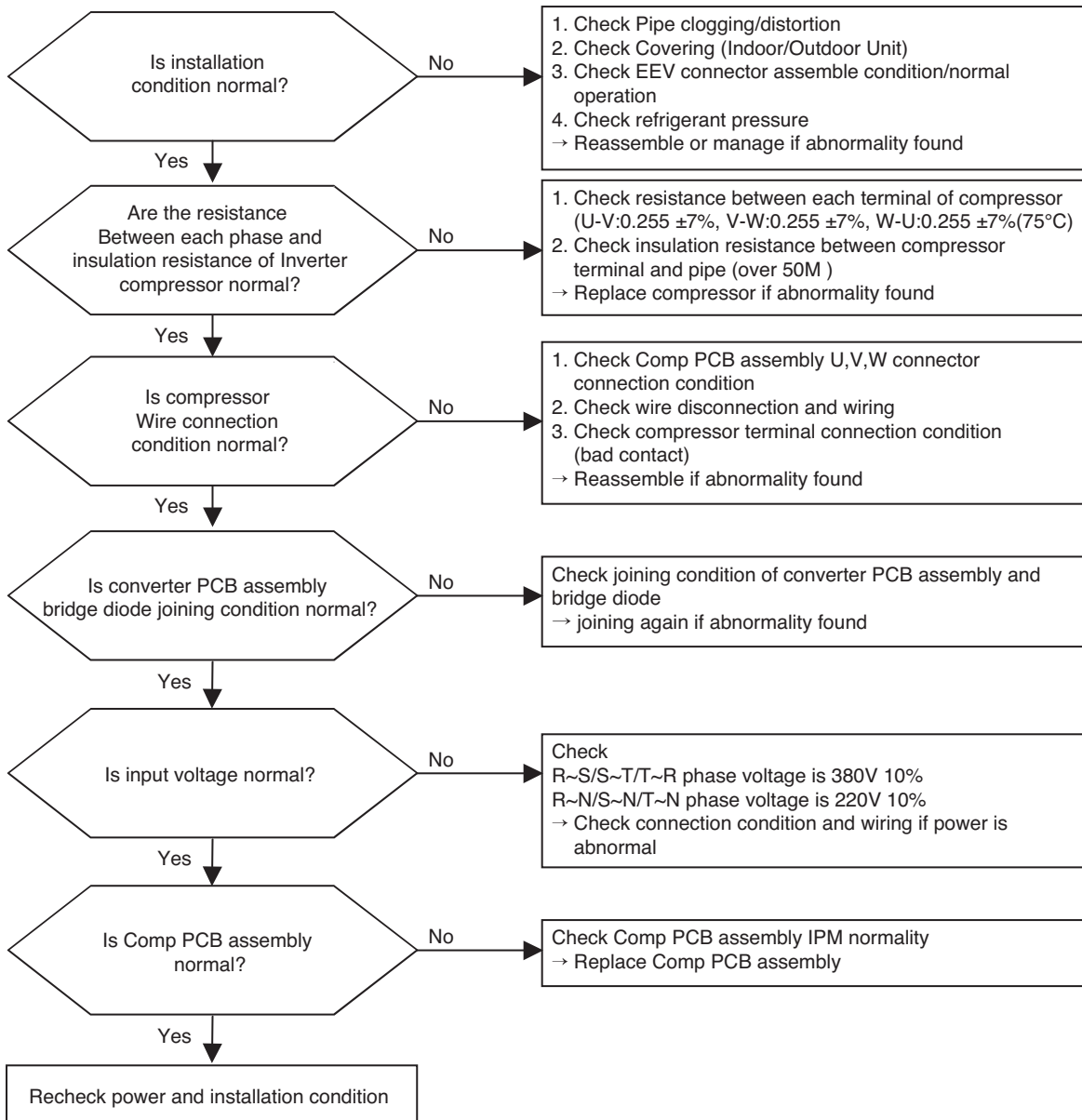

## Trouble Shooting Guide

\* Measuring resistance between each terminal of compressor



\* Measuring input voltage



\* Compressor wire connector connection



\* Check DC\_Link Connector joining condition

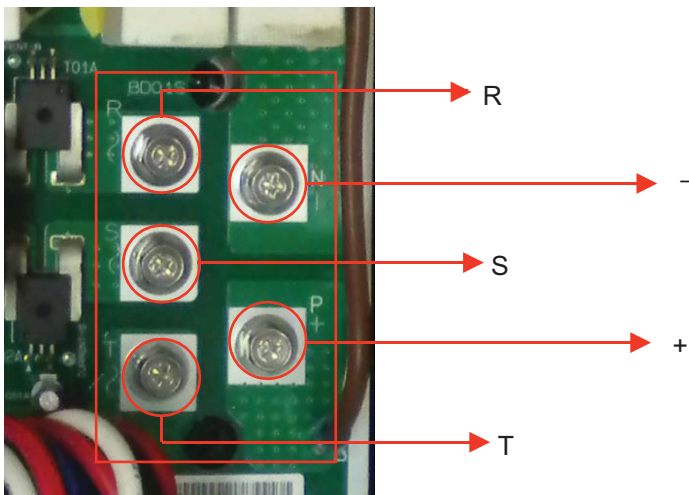

Error No.	Error Type	Error Point	Main Reasons
23* Master 231 Slave1 232 Slave2 233 Slave3 234	Inverter Compressor DC Link Low Voltage	DC Voltage isn't charged after starting relay on	<ol style="list-style-type: none"> <li>1. DC Link terminal misconnection/terminal contact fault</li> <li>2. Starting relay damage</li> <li>3. Condenser damage</li> <li>4. Comp PCB assembly damage (DC Link voltage sensing part)</li> <li>5. Input voltage low</li> </ol>

■ Error Diagnosis and Countermeasure Flow Chart

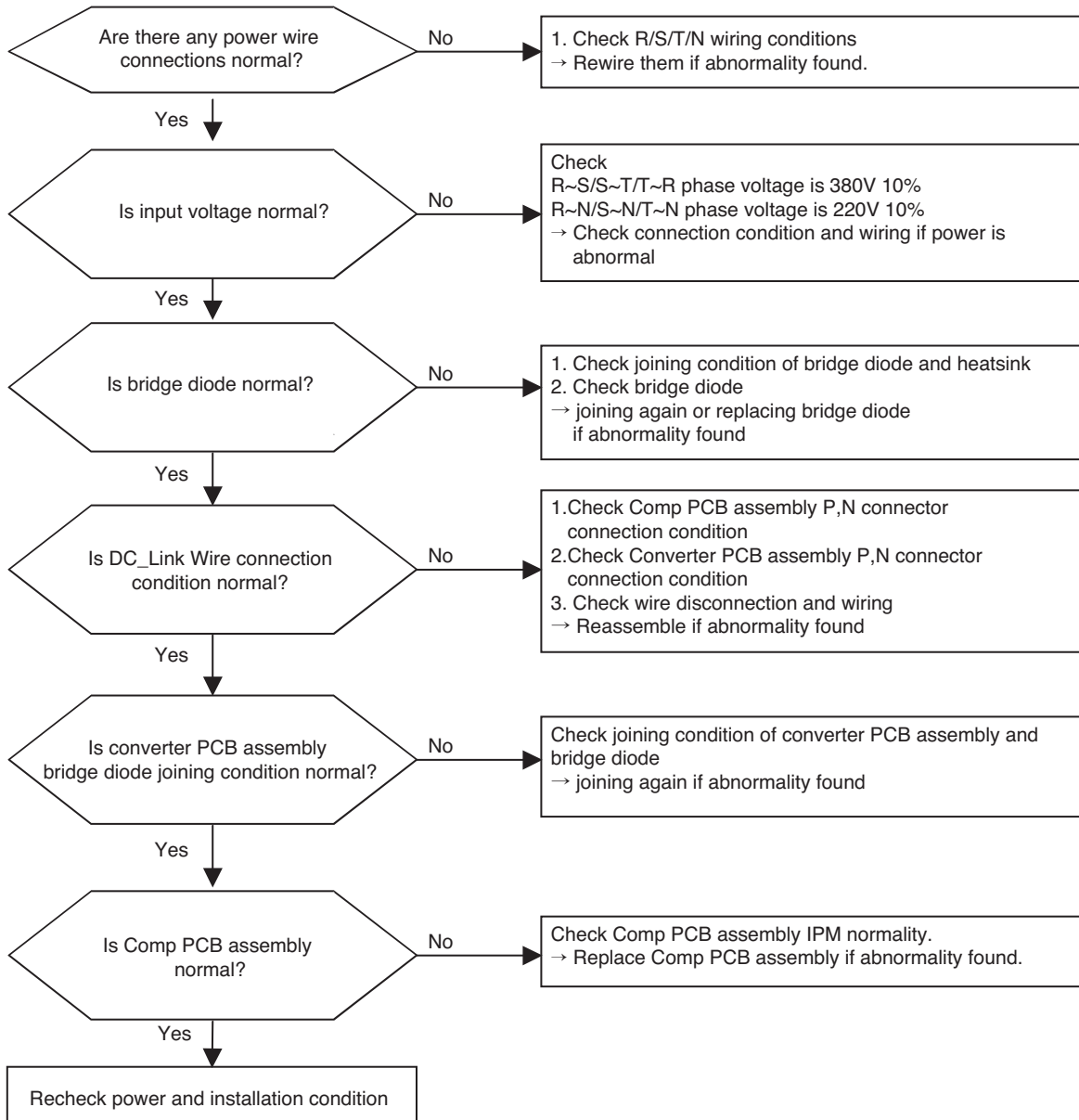

## Trouble Shooting Guide

---

\* Check DC\_Link Connector joining condition

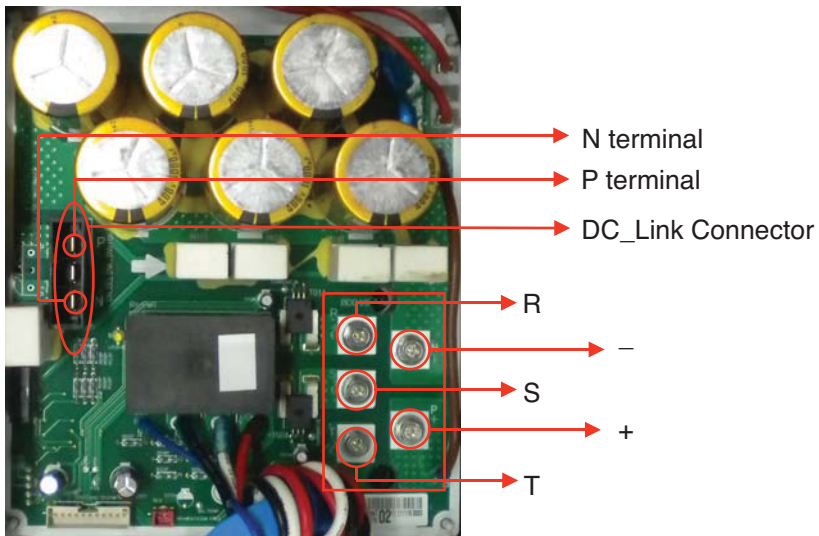

\* Measuring input voltage



Error No.	Error Type	Error Point	Main Reasons
24* Master 241 Slave1 242 Slave2 243 Slave3 244	Excessive rise of discharge pressure in outdoor compressor	Compressor off due to the high pressure switch in outdoor unit	<ol style="list-style-type: none"> <li>1. Defective high pressure switch</li> <li>2. Defective fan of indoor unit or outdoor unit</li> <li>3. Check valve of compressor clogged</li> <li>4. Pipe distortion due to the pipe damage</li> <li>5. Refrigerant overcharge</li> <li>6. Defective LEV at the indoor or outdoor unit .</li> <li>7. Covering or clogging(Outdoor covering during the cooling mode /Indoor unit filter clogging during the heating mode)</li> <li>8. SVC valve clogging</li> <li>9. Defective outdoor PCB</li> </ol>

**■ Error diagnosis and countermeasure flow chart**

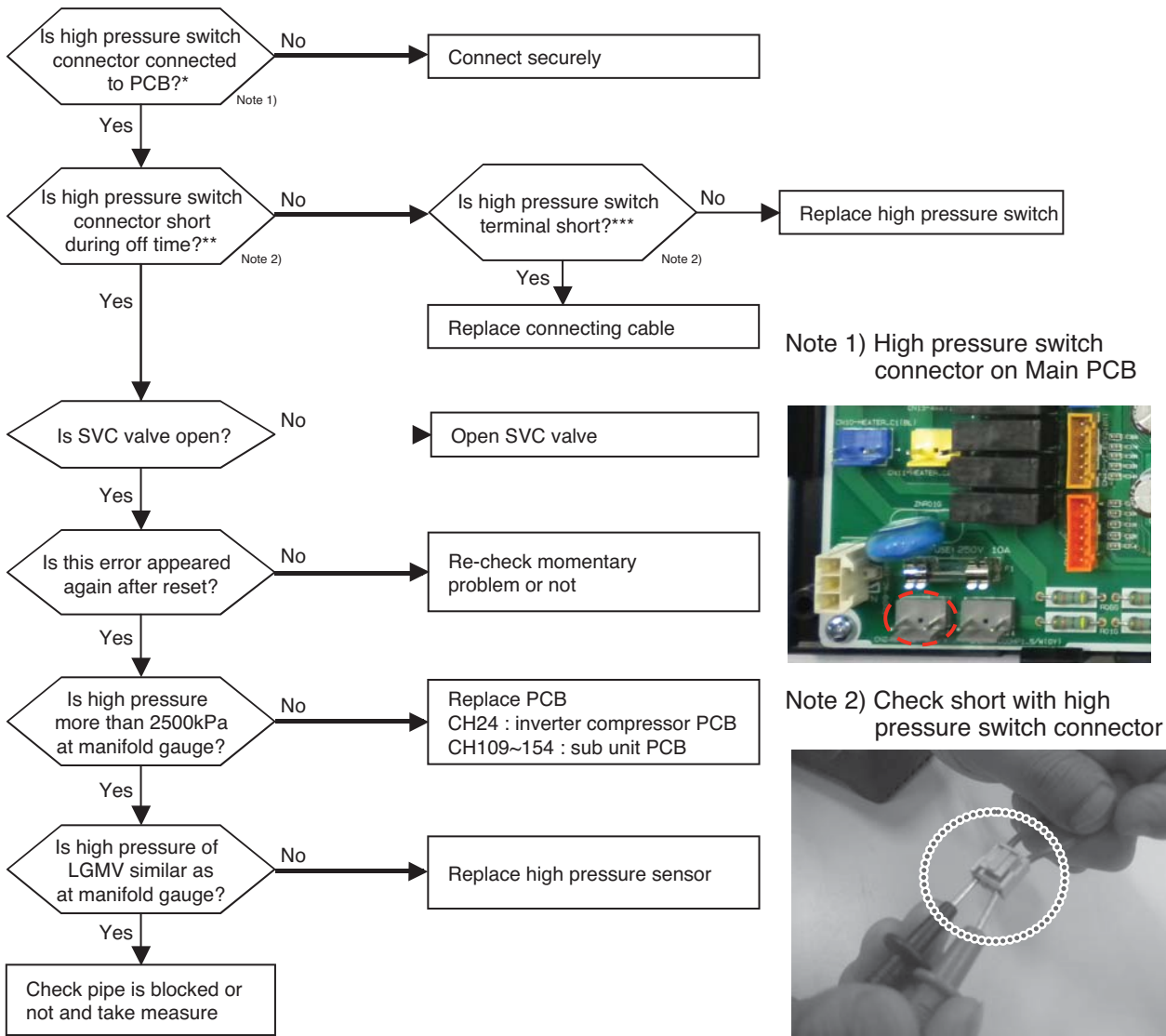

Error No.	Error Type	Error Point	Main Reasons
25* Master 251 Slave1 252 Slave2 253 Slave3 254	Input Voltage high/low	Input voltage is over limited value of the product (173V or less, 289V or more)	1. Input voltage abnormal (R-N) 2. Outdoor unit Converter PCB assembly damage (input voltage sensing part) 3. N phase line disconnection

■ Error Diagnosis and Countermeasure Flow Chart

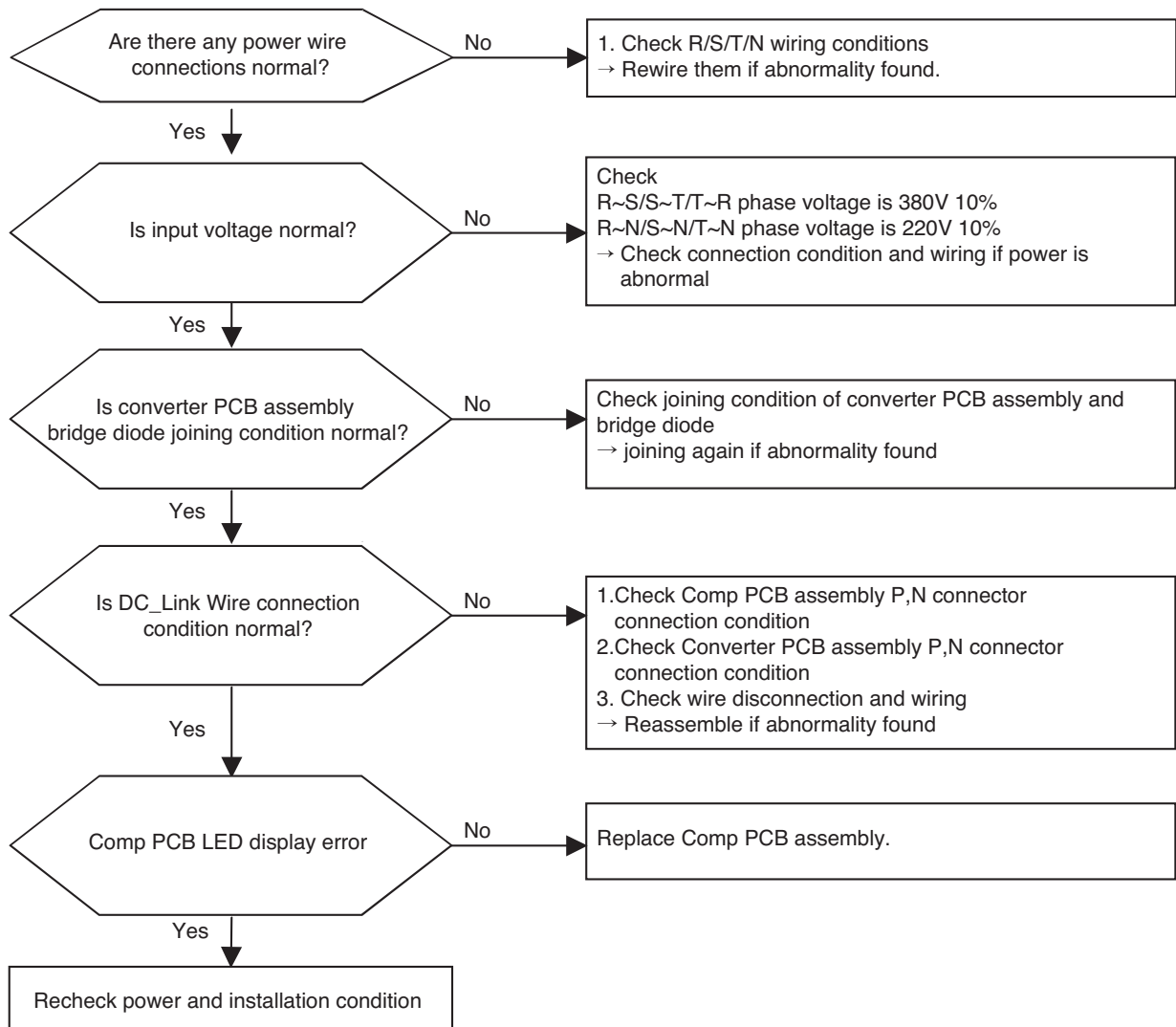

Error No.	Error Type	Error Point	Main Reasons
26* Master 261 Slave1 262 Slave2 263 Slave3 264	Inverter compressor starting failure Error	Starting failure because of compressor abnormality	<ol style="list-style-type: none"> <li>1. Overload operation (Pipe clogging/Covering/EEV defect/Ref. overcharge)</li> <li>2. Compressor damage (Insulation damage/Motor damage)</li> <li>3. Compressor wiring fault</li> <li>4. ODU Comp PCB damage (CT)</li> </ol>

■ Error Diagnosis and Countermeasure Flow Chart

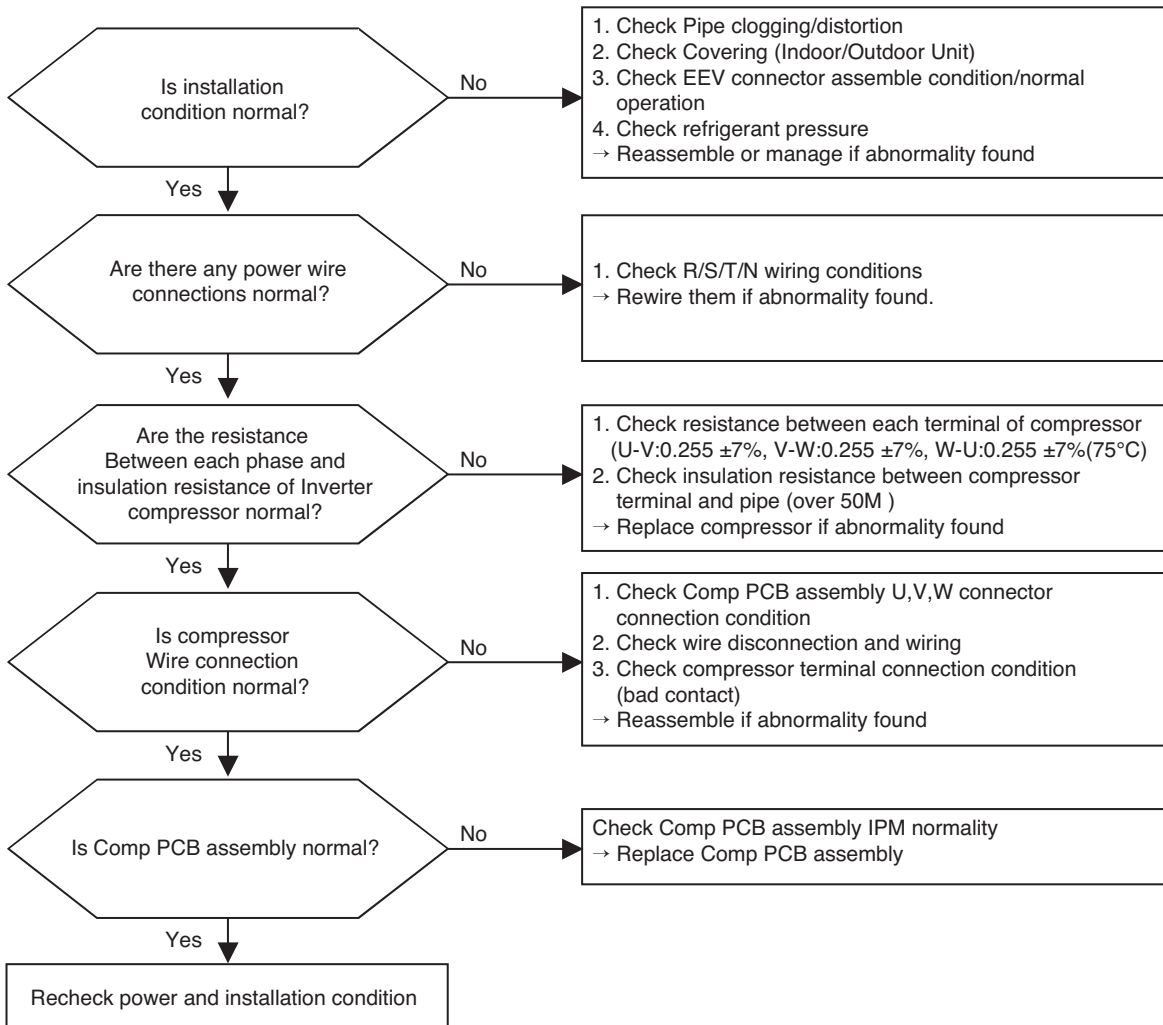

## Trouble Shooting Guide

---

- \* Measuring resistance between each terminal of compressor



- \* Compressor wire connection

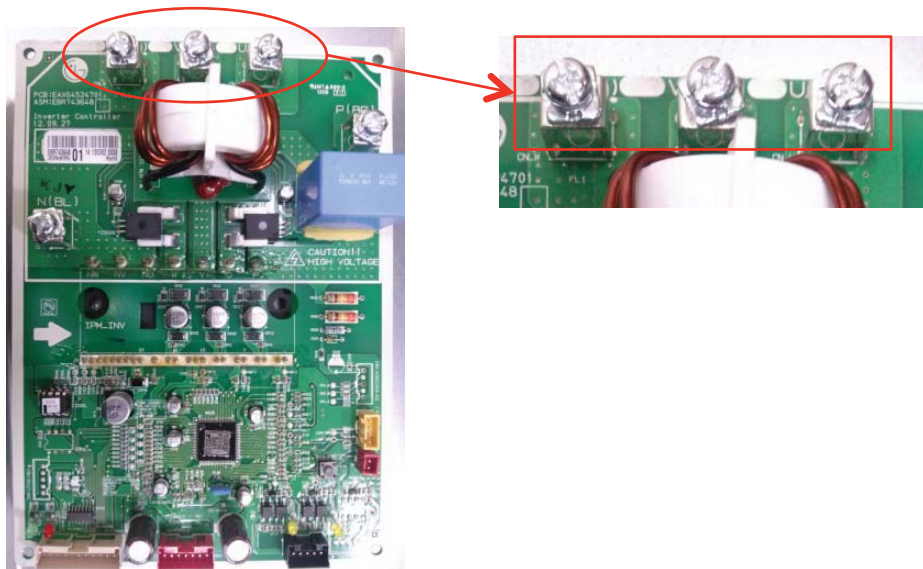

Error No.	Error Type	Error Point	Main Reasons
28* Master 281 Slave1 282 Slave2 283 Slave3 284	Inverter DC link high voltage error	Inv PCB DC link voltage supplied over 780V	1. Input voltage abnormal (R,S,T,N) 2. ODU Comp PCB damage (DC Link voltage sensing part)

■ Error Diagnosis and Countermeasure Flow Chart

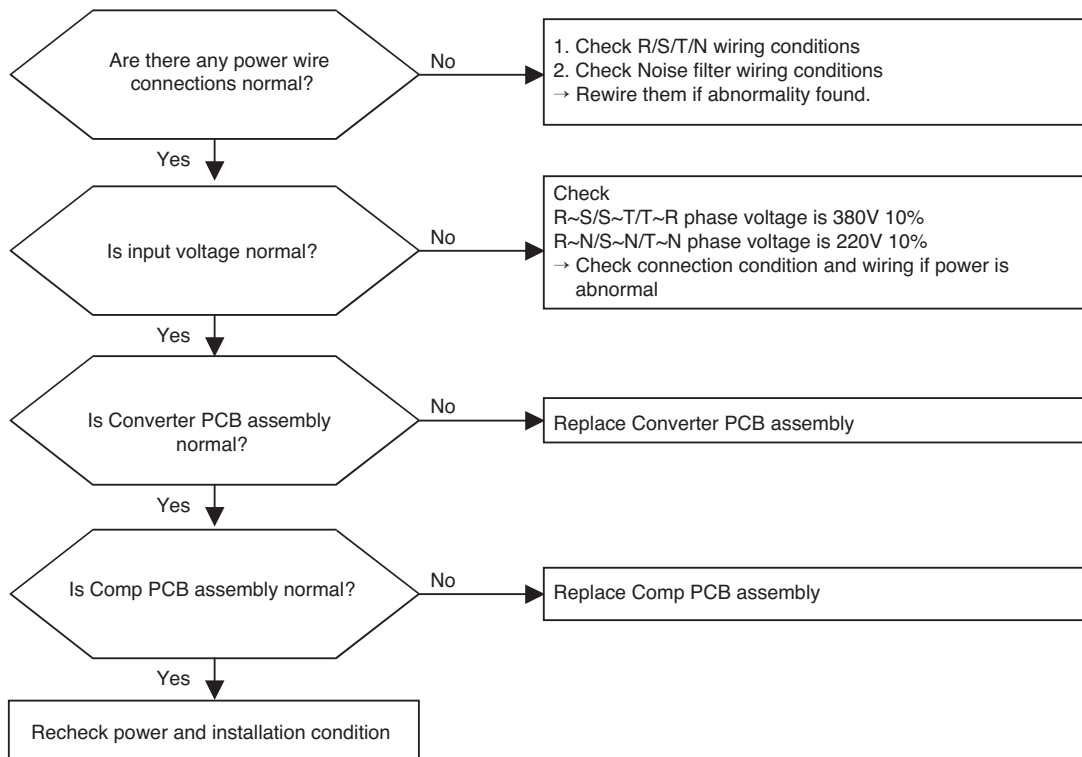

\* Measuring input voltage



\* Noise filter wiring



Error No.	Error Type	Error Point	Main Reasons
29* Master 291 Slave1 292 Slave2 293 Slave3 294	Inverter compressor over current	Inverter compressor input current is over 30A	<ol style="list-style-type: none"> <li>1. Overload operation (Pipe clogging/Covering/EEV defect/Ref. overcharge)</li> <li>2. Compressor damage(Insulation damage/Motor damage)</li> <li>3. Input voltage low</li> <li>4. ODU Comp PCB assembly damage</li> </ol>

■ Error Diagnosis and Countermeasure Flow Chart

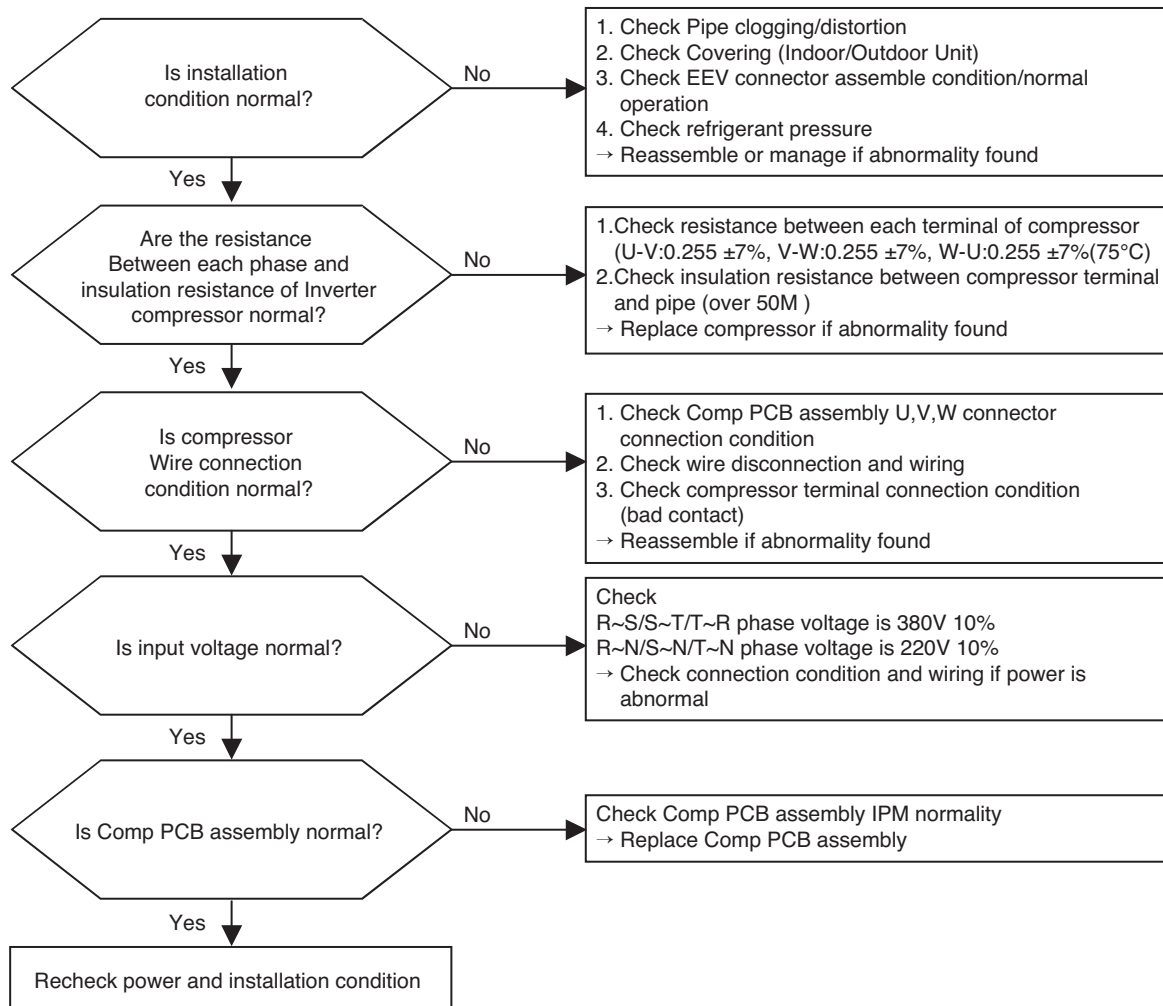

\* Measuring resistance between each terminal of compressor



\* Measuring input voltage



\* Compressor wire connection

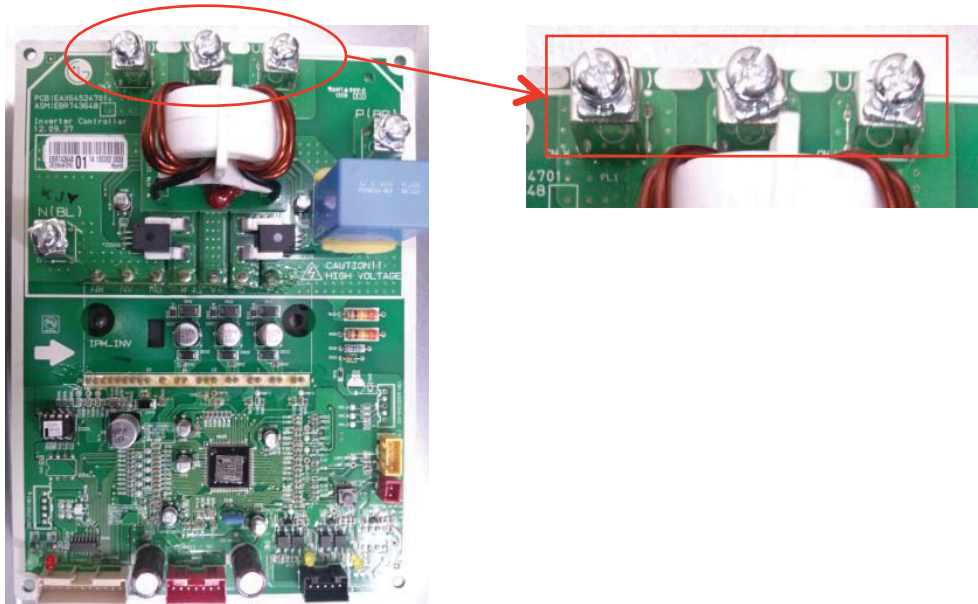

## Trouble Shooting Guide

Error No.	Error Type	Error Point	Main Reasons
32* Master 321 Slave1 322 Slave2 323 Slave3 324	Over-increase discharge temperature of inverter compressor 1 at main outdoor unit	Compressor is off because of over-increase discharge temperature of inverter compressor 1	<ol style="list-style-type: none"> <li>1. Temperature sensor defect of inverter compressor 1 discharge pipe</li> <li>2. Refrigerant shortage / leak</li> <li>3. EEV defect</li> <li>4. Liquid injection valve defect</li> </ol>
33* Master 331 Slave1 332 Slave2 333 Slave3 334	Over-increase discharge temperature of inverter compressor 2 at main outdoor unit	Compressor is off because of over-increase discharge temperature of inverter compressor 2	<ol style="list-style-type: none"> <li>1. Temperature sensor defect of inverter compressor 2 discharge pipe</li> <li>2. Refrigerant shortage / leak</li> <li>3. EEV defect</li> <li>4. Liquid injection valve defect</li> </ol>

### ■ Error diagnosis and countermeasure flow chart

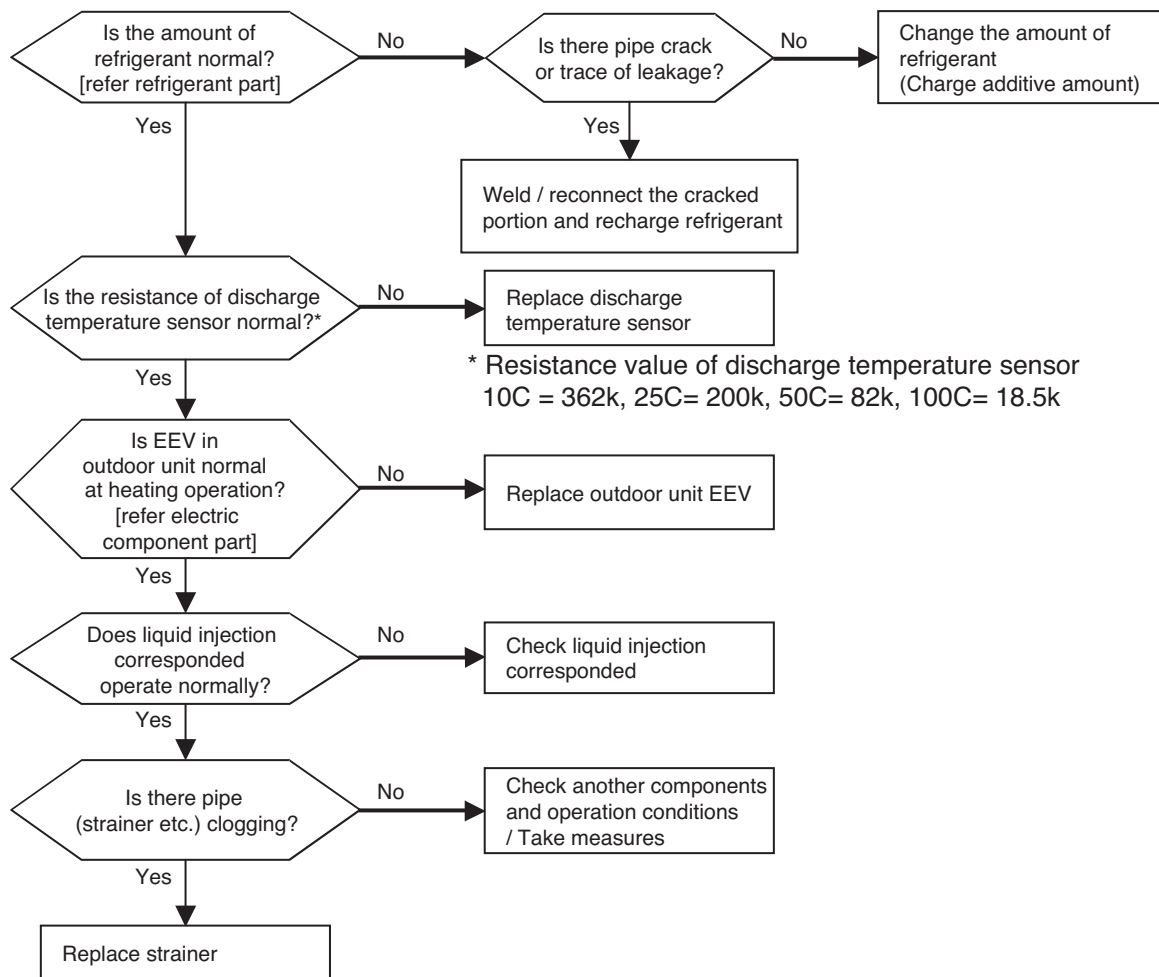

Error No.	Error Type	Error Point	Main Reasons
34*	Over-increase of discharge pressure of compressor	Error happens because of 3 times successive compressor off due to over-increase of high pressure by high pressure sensor	1. Defect of high pressure sensor
Master 341			2. Defect of indoor or outdoor unit fan
Slave1 342			3. Deformation because of damage of refrigerant pipe
Slave2 343			4. Over-charged refrigerant
Slave3 344			5. Defective indoor / outdoor unit EEV
			6. When blocked - Outdoor unit is blocked during cooling - Indoor unit filter is blocked during heating
			7. SVC valve is clogged
			8. PCB defect of outdoor unit
			10. Indoor unit pipe temperature sensor defect

■ Error diagnosis and countermeasure flow chart

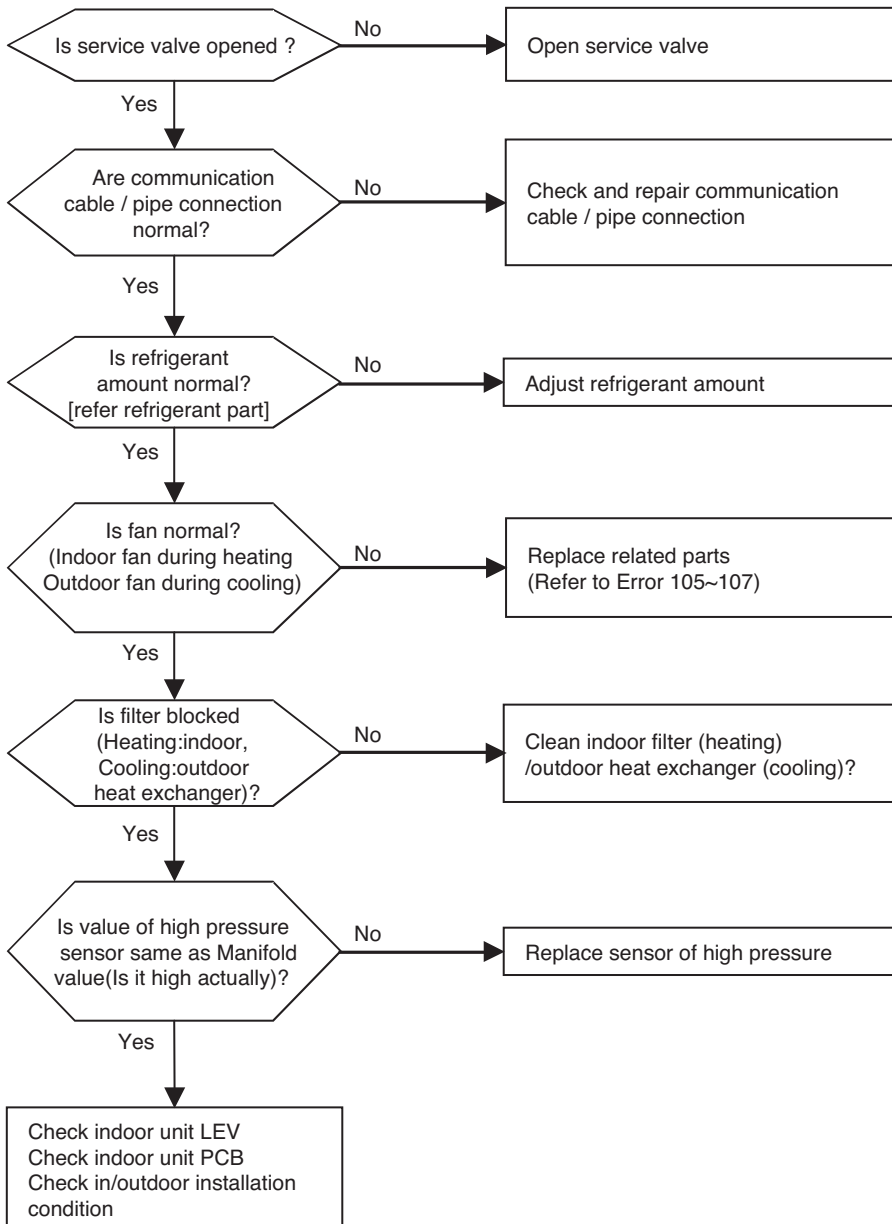

## Trouble Shooting Guide

Error No.	Error Type	Error Point	Main Reasons
35* Master 351 Slave1 352 Slave2 353 Slave3 354	Excessive drop of discharge pressure of compressor	Error happens because of 3 times successive compressor off due to excessive drop of low pressure by the low pressure sensor	<ol style="list-style-type: none"> <li>1. Defective low pressure sensor</li> <li>2. Defective outdoor/indoor unit fan</li> <li>3. Refrigerant shortage/leakage</li> <li>4. Deformation because of damage of refrigerant pipe</li> <li>5. Defective indoor / outdoor unit EEV</li> <li>6. Covering / clogging (outdoor unit covering during the cooling mode/ indoor unit filter clogging during heating mode)</li> <li>7. SVC valve clogging</li> <li>8. Defective outdoor unit PCB</li> <li>9. Defective indoor unit pipe sensor</li> </ol>

### ■ Error diagnosis and countermeasure flow chart

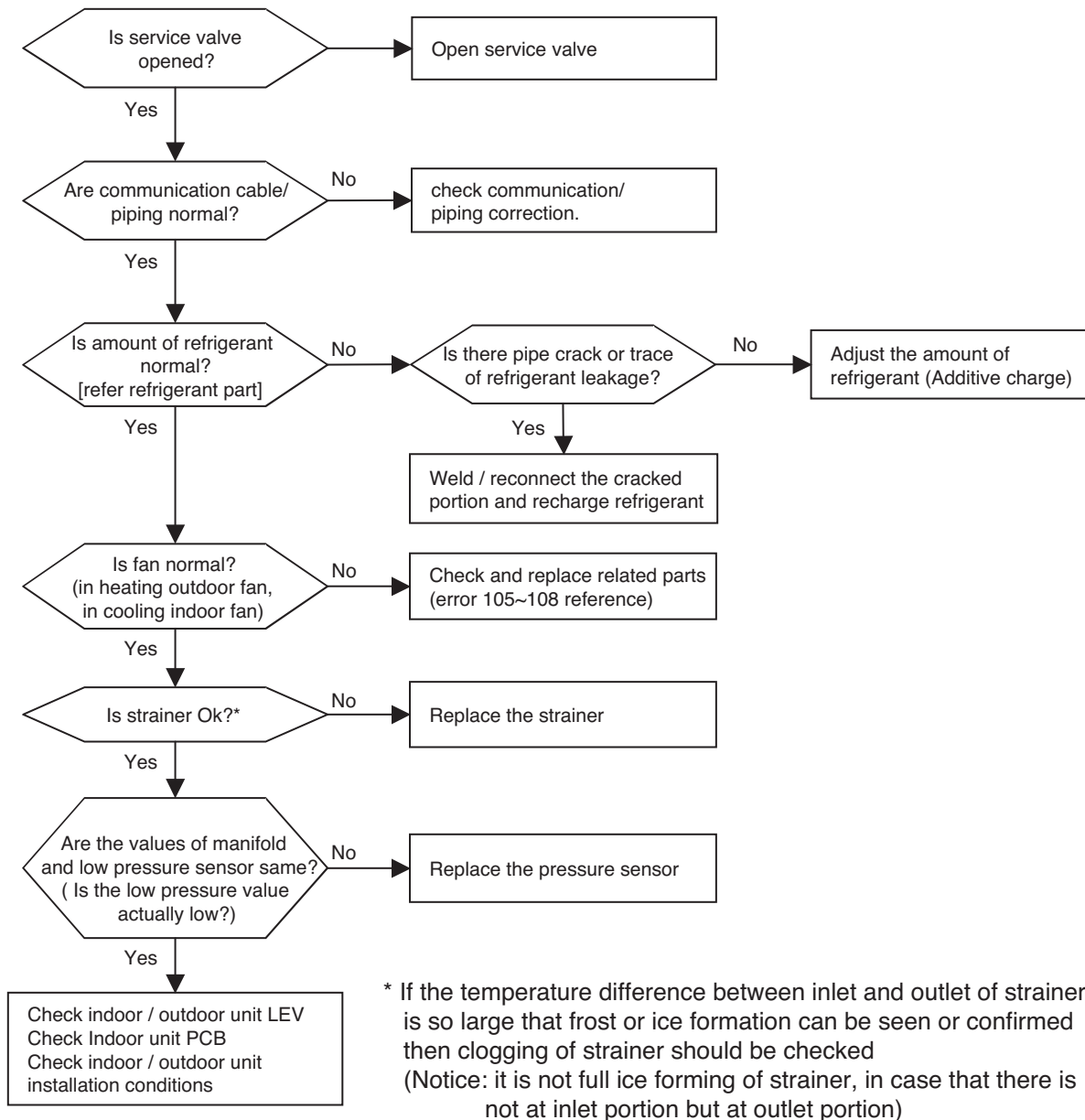

Error No.	Error Type	Error Point	Main Reasons
40* Master 401 Slave1 402 Slave2 403 Slave3 404	Inverter compressor CT sensor error	Micom input voltage isn't within 2.5V $\pm$ 0.3V at initial state of power supply	1. Input voltage abnormal (R-N) 2. ODU Comp PCB damage (CT sensing part)

■ Error Diagnosis and Countermeasure Flow Chart

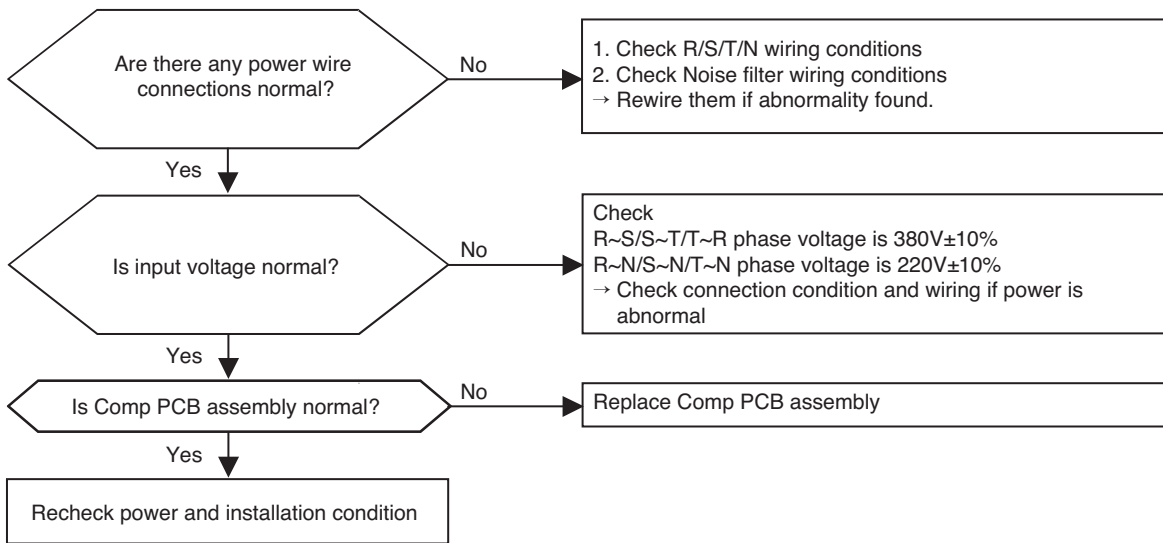

\* Measuring input voltage



\* Comp PCB assembly



## Trouble Shooting Guide

Error No.	Error Type	Error Point	Main Reasons
41* (Inverter1) Master 411 Slave1 412 Slave2 413 Slave3 414	Compressor1 discharge pipe temperature sensor error	Sensor measurement value is abnormal (Open/Short)	<ol style="list-style-type: none"> <li>1. Defective connection of the compressor1 discharge pipe temperature sensor</li> <li>2. Defective discharge pipe compressor sensor of the compressor1 (open/short)</li> <li>3. Defective outdoor PCB</li> </ol>
47* (Inverter2) Master 471 Slave1 472 Slave2 473 Slave3 474	Compressor2 discharge pipe temperature sensor error	Sensor measurement value is abnormal (Open/Short)	<ol style="list-style-type: none"> <li>1. Defective connection of the compressor1 discharge pipe temperature sensor</li> <li>2. Defective discharge pipe compressor sensor of the compressor1 (open/short)</li> <li>3. Defective outdoor PCB</li> </ol>

### ■ Error diagnosis and countermeasure flow chart

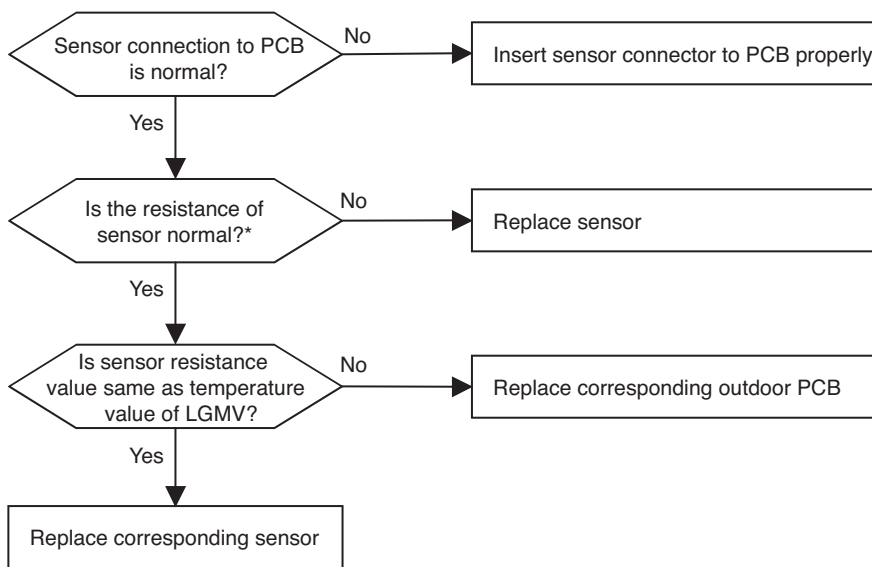

\* Error is generated if the resistance is more than 5M(open) and less than 2k (short)

Note: Standard values of resistance of sensors at different temperatures (5% variation)  
 10C = 362k : 25C= 200k : 50C= 82k : 100C= 18.5k

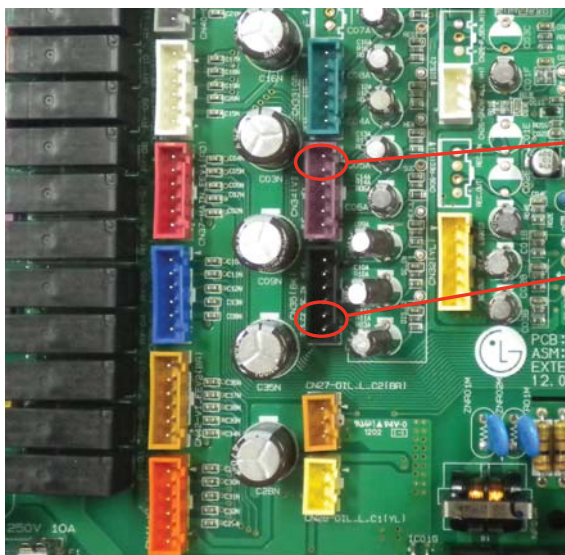

Check the resistance inverter compressor discharge temperature sensor

Error No.	Error Type	Error Point	Main Reasons
42* Master 421 Slave1 422 Slave2 423 Slave3 424	Sensor error of low pressure	Abnormal value of sensor (Open/Short)	1. Bad connection of low pressure connector 2. Defect of low pressure connector (Open/Short) 3. Defect of outdoor PCB
43* Master 431 Slave1 432 Slave2 433 Slave3 434	Sensor error of high pressure	Abnormal value of sensor (Open/Short)	1. Bad connection of high pressure connector 2. Defect of high pressure connector (Open/Short) 3. Defect of outdoor PCB

■ Error diagnosis and countermeasure flow chart

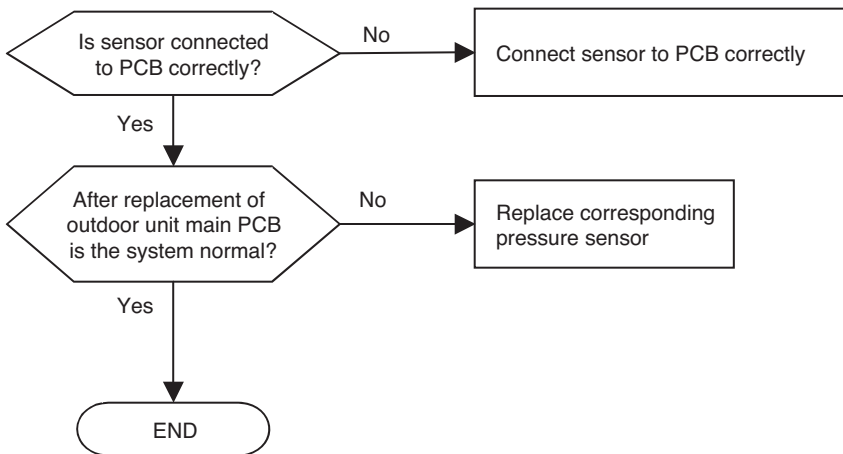

Pressure sensor connector

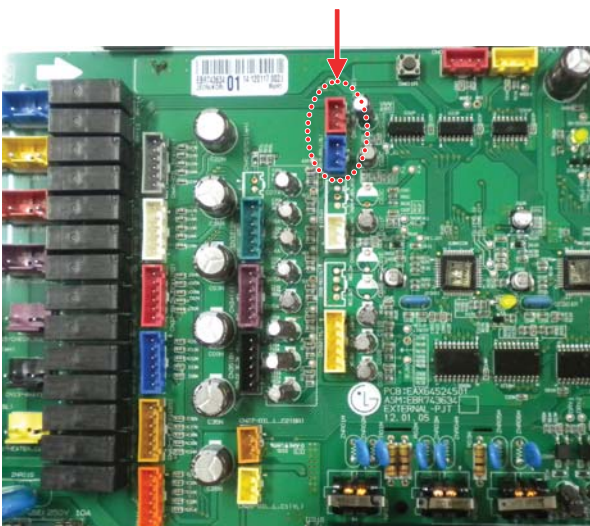

Error No.	Error Type	Error Point	Main Reasons
44* Master 441 Slave1 442 Slave2 443 Slave3 444	Sensor error of outdoor air temperature	Abnormal value of sensor (Open/Short)	1. Bad connection of air temperature connector 2. Defect of air temperature connector(Open/Short) 3. Defect of outdoor PCB
45* Master 451 Slave1 452 Slave2 453 Slave3 454	Piping temperature sensor error of heat exchanger in master & slave outdoor unit heat exchanger (A,B)	Abnormal value of sensor (Open/Short)	1. Bad connection of air temperature connector 2. Defect of air temperature connector(Open/Short) 3. Defect of outdoor PCB
46* Master 461 Slave1 462 Slave2 463 Slave3 464	Compressor suction temperature sensor error	Abnormal value of sensor (Open/Short)	1. Bad connection of air temperature connector 2. Defect of air temperature connector(Open/Short) 3. Defect of outdoor PCB
49* Master 491 Slave1 492 Slave2 493 Slave3 494	Outdoor Unit IPM Temperature Sensor Fault	Outdoor Unit IPM Temperature Sensor Open or Short	1. Bad connection of air temperature connector 2. Defect of air temperature connector(Open/Short) 3. Defect of outdoor PCB

**■ Error diagnosis and countermeasure flow chart**

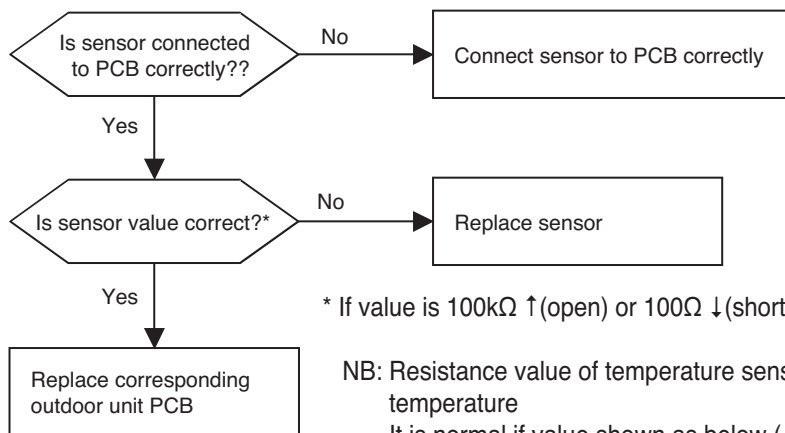

\* If value is 100kΩ ↑(open) or 100Ω ↓(short), error occurs

NB: Resistance value of temperature sensor change according to temperature

It is normal if value shown as below (±5% error)

Sensor of air temperature: 10°C = 20.7kΩ : 25°C= 10kΩ : 50°C= 3.4kΩ

Sensor of piping temperature: 10°C = 10kΩ : 25°C= 5Ωk : 50°C= 1.8kΩ

Error No.	Error Type	Error Point	Main Reasons
153* Master 1531 Slave1 1532 Slave2 1533 Slave3 1534	Outdoor Unit Upper Heat Exchanger Temperature Sensor Fault	Outdoor Unit Upper Heat Exchanger Temperature Sensor open or short	1. Temperature Sensor Connecting Fault 2. Temperature Sensor(Open/Short) 3. Main PCB Fault
154* Master 1541 Slave1 1542 Slave2 1543 Slave3 1544	Outdoor Unit Low Heat Exchanger Temperature Sensor Fault	Outdoor Unit Low Heat Exchanger Temperature Sensor open or short	1. Temperature Sensor Connecting Fault 2. Temperature Sensor(Open/Short) 3. Main PCB Fault

Error No.	Error Type	Error Point	Main Reasons
50* Master 501 Slave1 502 Slave2 503 Slave3 504	ODU 3phase power omission error	Omitting one or more of R,S,T input power	<ol style="list-style-type: none"> <li>1. Input Voltage abnormal (R,S,T,N)</li> <li>2. Check power Line connection condition</li> <li>3. Converter PCB damage</li> <li>4. Converter PCB input current sensor fault</li> </ol>

■ Error Diagnosis and Countermeasure Flow Chart

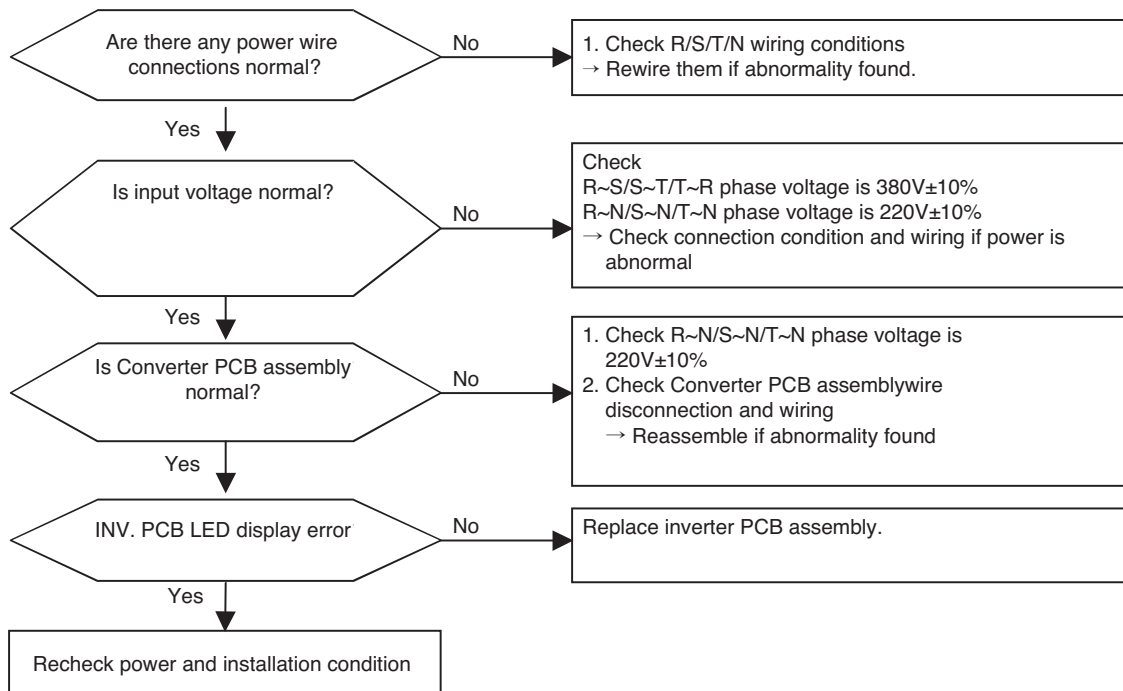

\* Measuring input voltage



\* Noise filter wiring

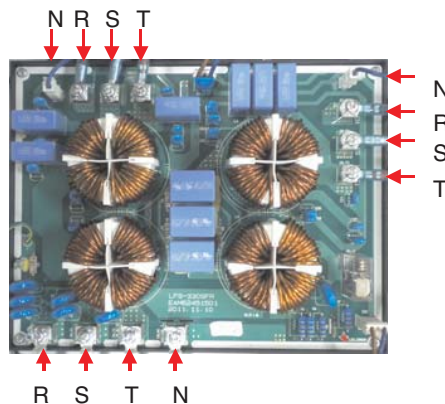

\* Field Fault Case

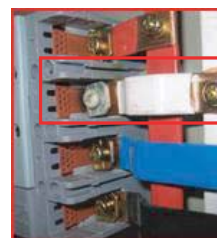

\* R-Phase Terminal Changed Color.

Error No.	Error Type	Error Point	Main Reasons
51* Master 511	Over-Capacity (Sum of indoor unit capacity is more than outdoor capacity)	Sum of indoor unit capacity exceed outdoor unit capacity specification	1. 130% more than outdoor unit rated capacity 2. Wrong connection of communication cable/piping 3. Control error of slave outdoor unit Dip switch 4. Power supply defect of slave unit PCB 5. Defect of outdoor unit PCB

■ Error diagnosis and countermeasure flow chart

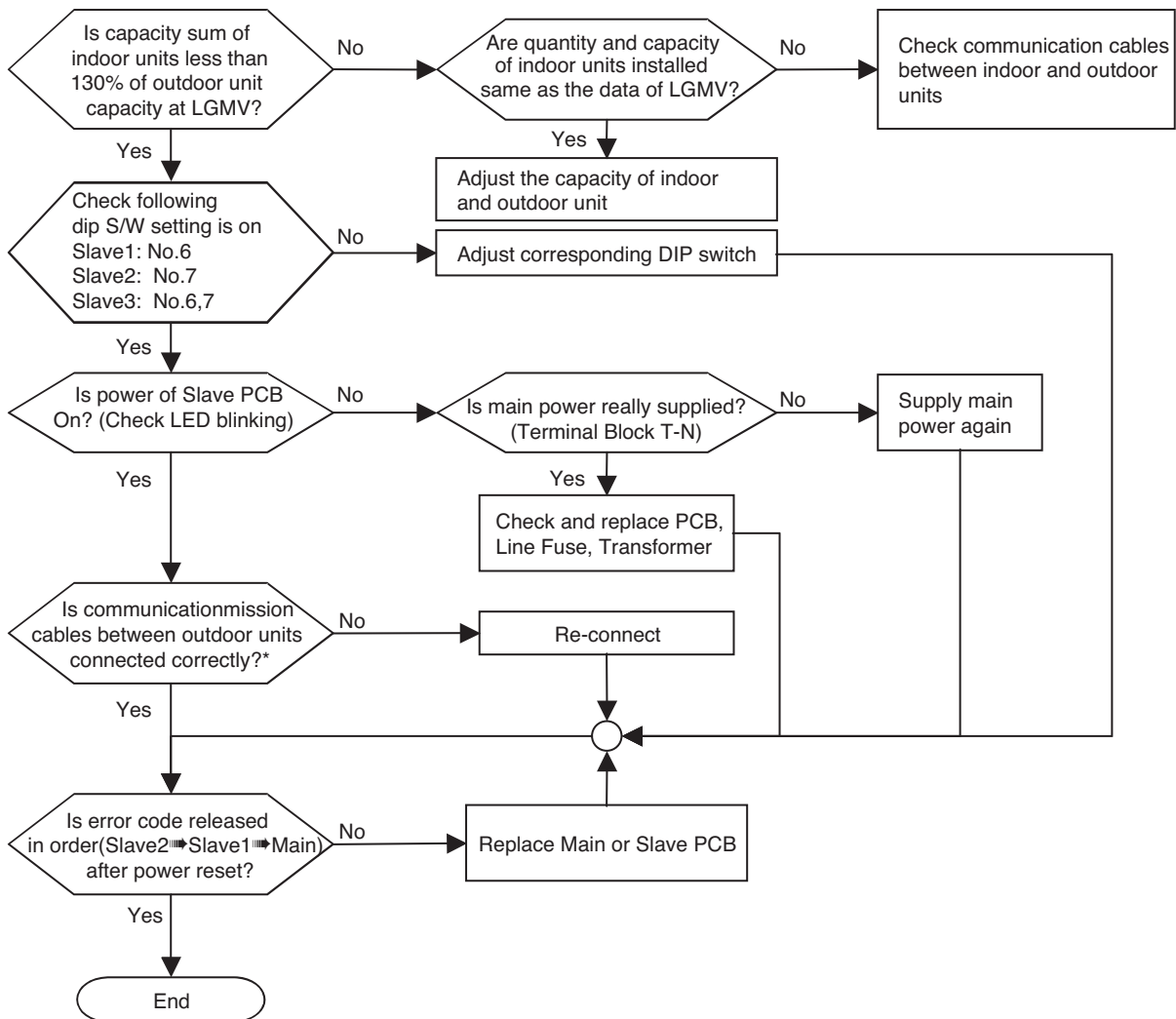

\* In order to check communication cables between outdoor units, check in order as below : PCB connectors → terminal block → communication cables

Error No.	Error Type	Error Point	Main Reasons
52* Master 521 Slave1 522 Slave2 523 Slave3 524	Communication error between (Comp1/Comp2 PCB → Main PCB)	Main PCB of Master unit of Master unit can't receive signal from Comp1/Comp2 controller	1. Power cable or communication cable is not connected 2. Defect of outdoor Main PCB or Comp1/Comp2 PCB

■ Error diagnosis and countermeasure flow chart

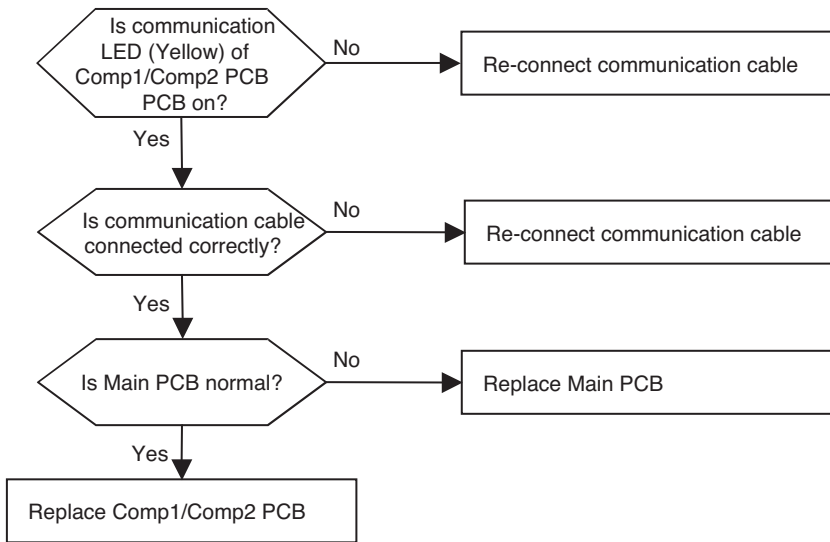

\* The method of checking Main PCB and Comp1/Comp2 PCB (If normal, communication LED blinks)

Comp1 Communication LED      Com2 Communication LED

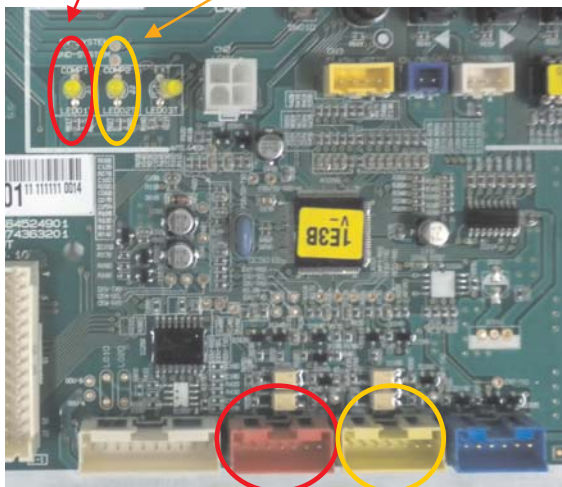

Comp1 Communication Connector      Comp2 Communication Connector

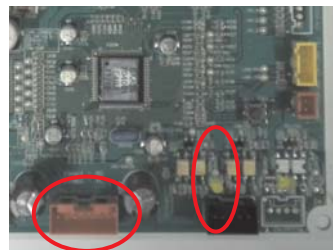

Communication Connector & LED in Comp1 PCB



Communication Connector & LED in Comp2 PCB

Error No.	Error Type	Error Point	Main Reasons
53* Master 531	Communication error (Indoor unit → Main PCB)	In case Main PCB can't receive signal from indoor unit	<ol style="list-style-type: none"> <li>1. Communication cables are not connected between External PCB and indoor PCB</li> <li>2. Communication cables are not connected between Main PCB and External PCB</li> <li>3. Communication cables are not connected between Main PCB and Communication PCB</li> <li>4. Communication cables are short/open</li> <li>5. Indoor PCB power off</li> <li>6. Defect of outdoor Cycle/Communication/indoor PCB</li> <li>7. Communication wire connection fault</li> </ol>

■ Error diagnosis and countermeasure flow chart

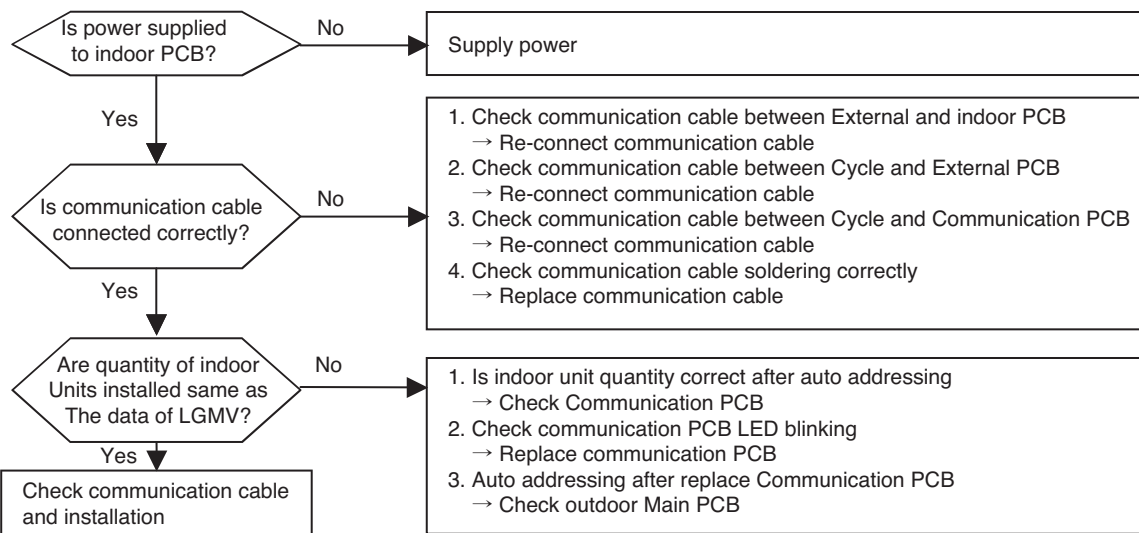

In case of CH53, almost happened with CH05, the indoor units not operated actually are normal so check with same method of CH05. and additionally check as shown as below and above flow chart

- Although the quantity of indoor units installed is same as LGMV data there may be a few indoor units with which the number of communication is not increased with LGMV
- Although the quantity of indoor units installed is not same as LGMV data, and if communication of the indoor unit displayed at LGMV is done well then the indoor unit suspected to have some problem (and is not appear at LGMV) may have following problems
  - ① wrong connection of communication cable or power cable
  - ② fault of power / PCB / communication cable
  - ③ duplication of indoor unit number
- If communication is not doing well wholly then the Auto Addressing is not done
- The case that CH53 appear at indoor unit also Auto Addressing is not done so indoor unit address may be duplicated

\* After replacement of indoor unit PCB, Auto Addressing should be done, if central controller is installed then the central control address also should be input.  
In case that only communication PCB is replaced above process is not needed

Outdoor Unit  
Communication PCB



Indoor Communication Part



Communication Part in Main PCB

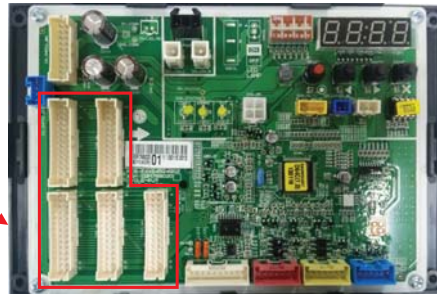

Communication Part in External PCB

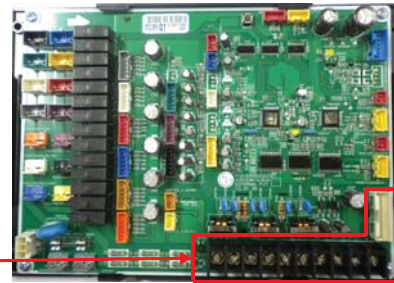

※ Remark : IDU A/IDU B

Wiring Fault Case



Indoor Unit  
Communication PCB



※ 1 time/10 sec Turn on/off

## Trouble Shooting Guide

Error No.	Error Type	Error Point	Main Reasons
57* Master 571 Slave1 572 Slave2 573 Slave3 574	Communication error : Main PCB --> Comp PCB	Failing to receive inverter signal at main PCB of Outdoor Unit	<ol style="list-style-type: none"> <li>1. Bad Connection Between Comp PCB and Comp PCB</li> <li>2. Communication Wire Noise Effect</li> <li>3. ODU Main PCB Damage</li> <li>4. ODU Main PCB Damage</li> </ol>

### ■ Error diagnosis and countermeasure flow chart

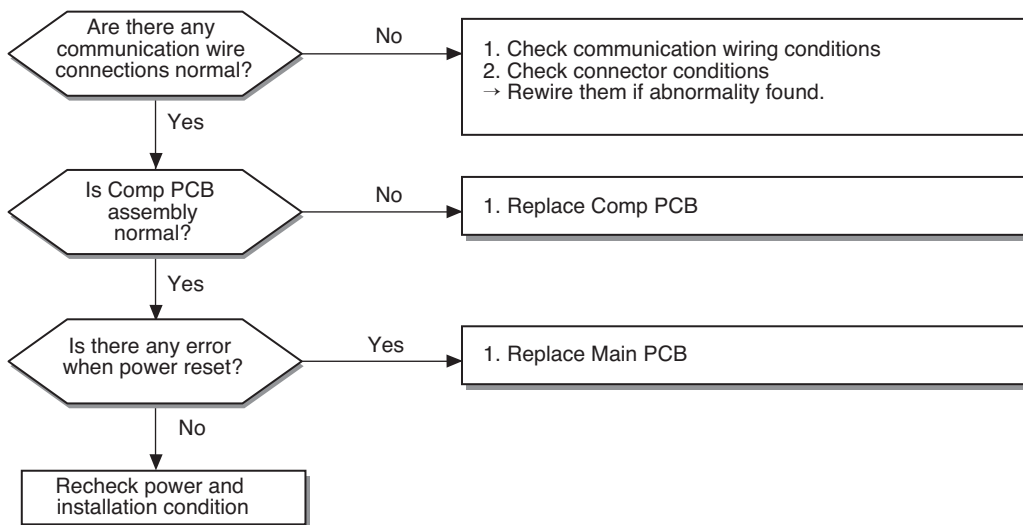

**Main PCB**

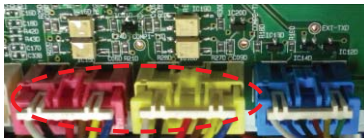

**Comp PCB**

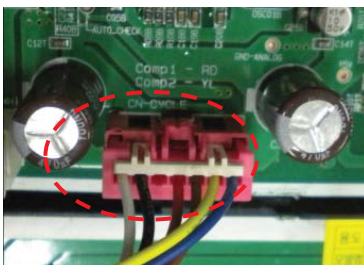

**C/Box Bottom**

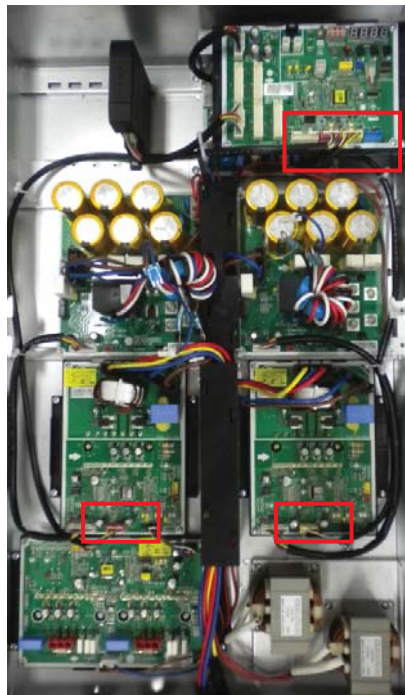

Error No.	Error Type	Error Point	Main Reasons
59* Master 591 Slave1 592 Slave2 593 Slave3 594	Series Installation Error	Series Installation of Slave Outdoor Unit Larger Than Master Capacity	1. Dip Switch Setting Error

**■ Error Diagnosis and Countermeasure Flow Chart**

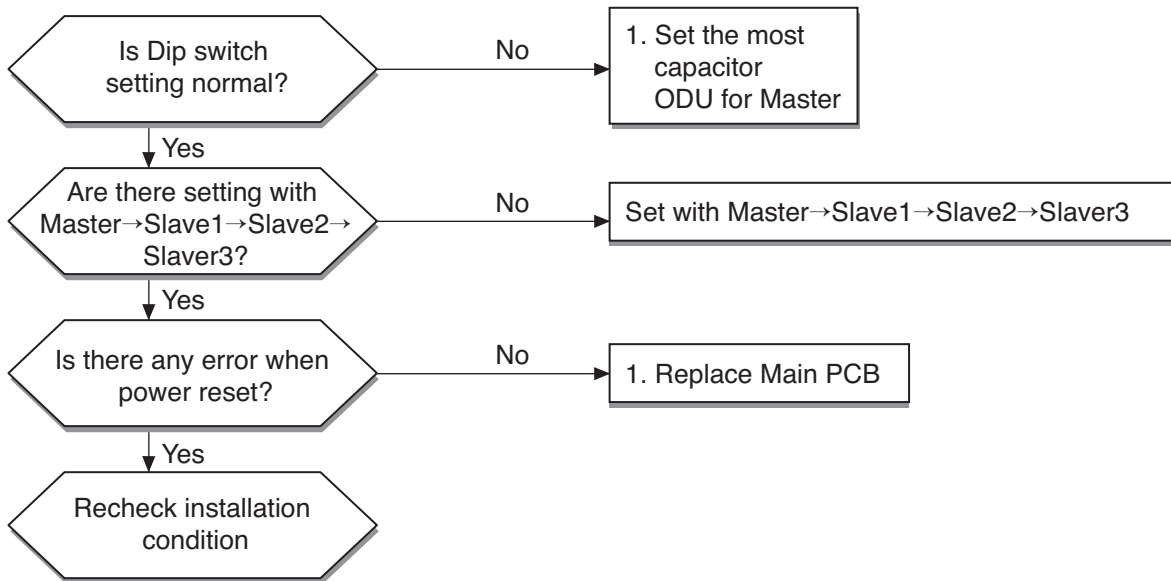

**\* Dip Switch Setting**

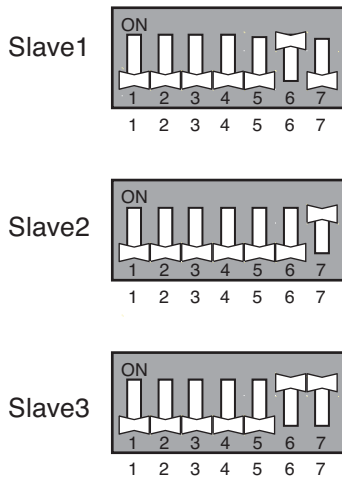

Error No.	Error Type	Error Point	Main Reasons
60* Master 601 Slave1 602 Slave2 603 Slave3 604	Comp PCB EEPROM error	EEPROM Access error and Check SUM error	1. EEPROM contact defect/wrong insertion 2. Different EEPROM Version 3. ODU Comp PCB assembly damage

■ Error Diagnosis and Countermeasure Flow Chart

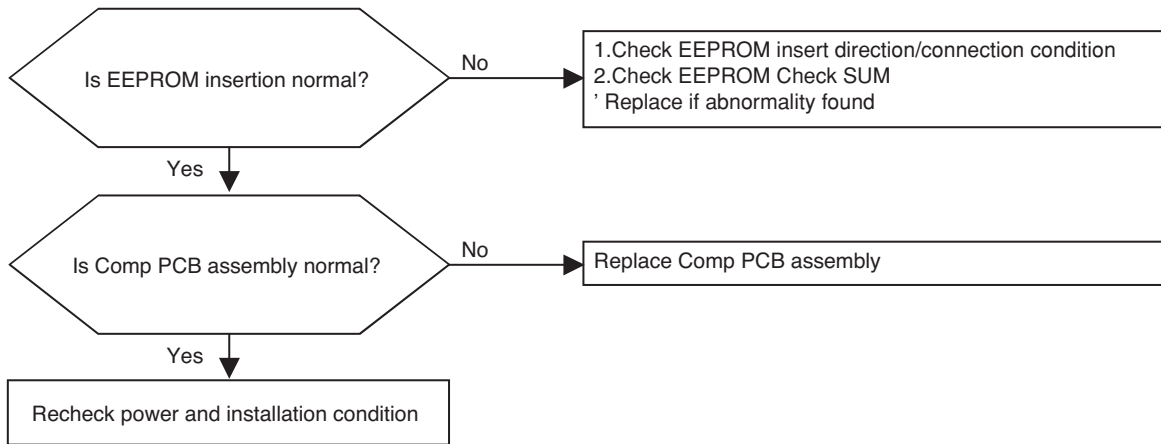

\* Inverter EEPROM inserting point

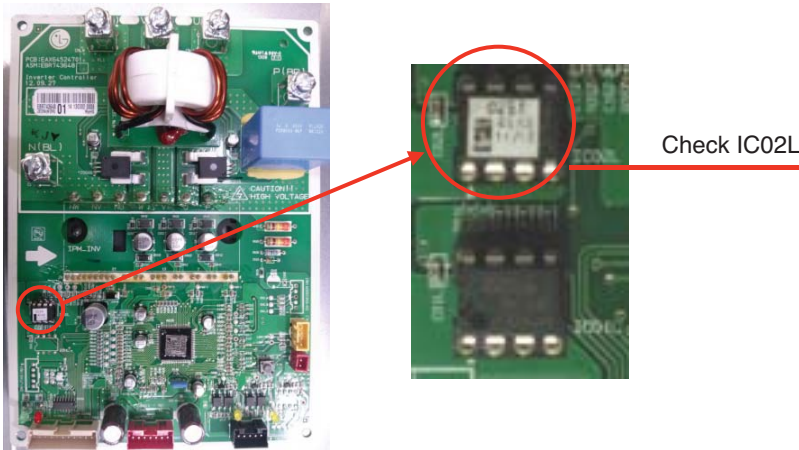

\* Right inserting direction of inverter EEPROM

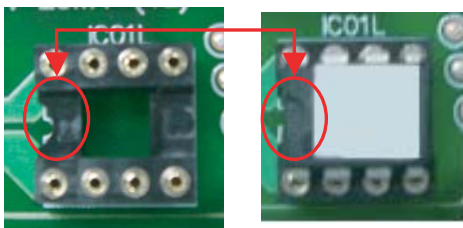

\* Note : Replace after power off

Error No.	Error Type	Error Point	Main Reasons
62* Master 621 Slave1 622 Slave2 623 Slave3 624	Inverter PCB Heatsink Temperature High	Heatsink Temperature is Over 90°C	<ol style="list-style-type: none"> <li>1. Inverter PCBA IPM Connection Condition Abnormal</li> <li>2. Outdoor Unit Fan Motor Operation Abnormal</li> <li>3. Outdoor Unit Inverter PCB Assembly Defect</li> <li>4. Overload Operation (Pipe Clogging/ Covering/EEV Defect/Ref. Overcharge)</li> </ol>

■ Error diagnosis and countermeasure flow chart

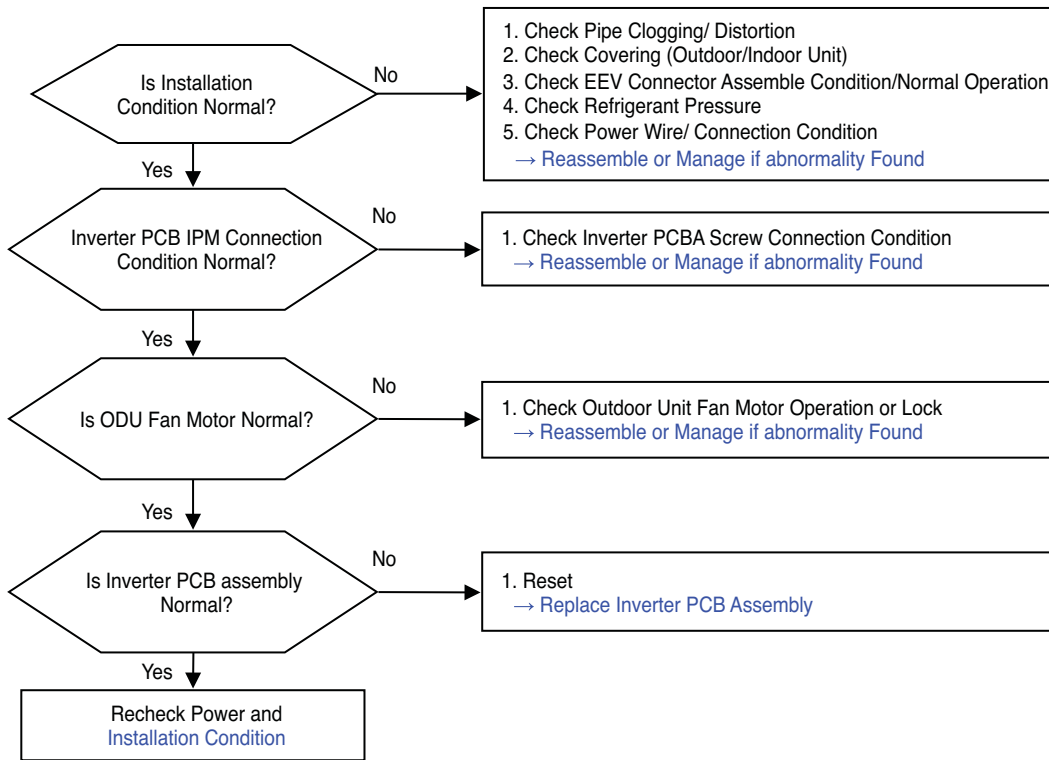

■ Check Inverter PCB Screw Connection Condition

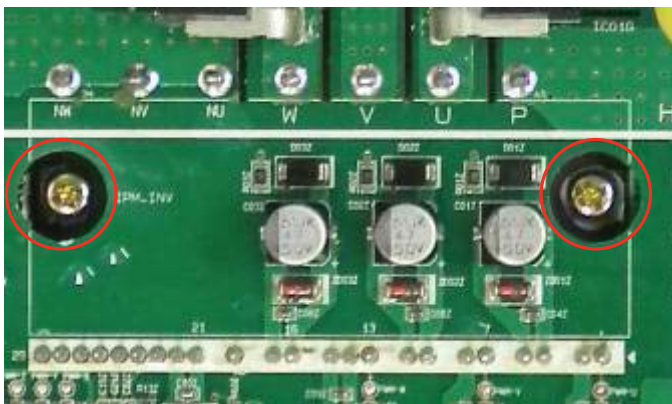

Check Screw Connection Condition

## Trouble Shooting Guide

Error No.	Error Type	Error Point	Main Reasons
65* Master 651 Slave1 652 Slave2 653 Slave3 654	Outdoor unit liquid pipe (condenser) temperature sensor error	Abnormal sensor resistance value (Open/Short)	<ol style="list-style-type: none"> <li>1. Defective temperature sensor connection</li> <li>2. Defective temperature sensor (Open / Short)</li> <li>3. Defective outdoor unit PCB</li> </ol>

### ■ Error diagnosis and countermeasure flow chart

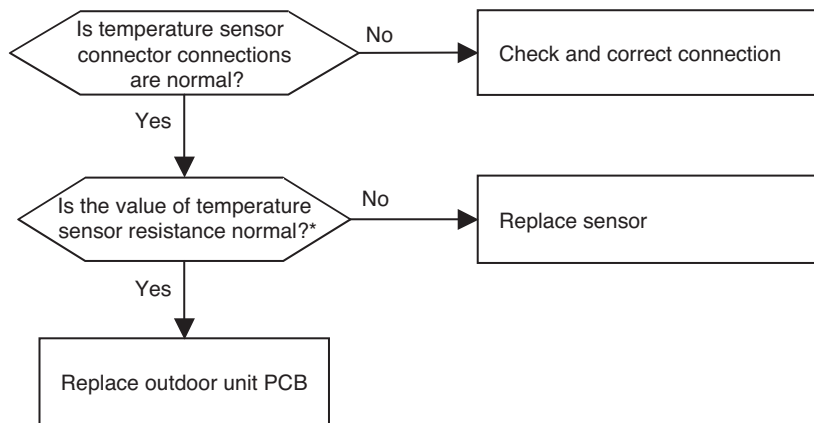

\* Sensor resistance 100 kΩ over (open) or 100 Ω below (short) will generate error

Note: Temperature sensor resistance varies with temperature, so compare temperature sensor resistance value according to outdoor unit temperature by referring below table (±5% tolerance)

Air temperature sensor: 10°C = 20.7kΩ : 25°C = 10kΩ : 50°C = 3.4kΩ

Pipe temperature sensor: 10°C = 10kΩ : 25°C = 5kΩ : 50°C = 1.8kΩ

Error No.	Error Type	Error Point	Main Reasons
67* Master 671 Slave1 672 Slave2 673 Slave3 674	Fan Lock Error	Fan RPM is 10RPM or less for 5 sec. when ODU fan starts or 40 RPM or less after fan starting.	<ol style="list-style-type: none"> <li>1. Fan motor defect / assembly condition abnormal</li> <li>2. Wrong connection of fan motor connector (U,V,W output)</li> <li>3. Reversing rotation after RPM target apply</li> <li>4. Fan PCB assembly defect</li> <li>5. Fan lock by Heavy Snowfall.</li> </ol>

■ Error Diagnosis and Countermeasure Flow Chart

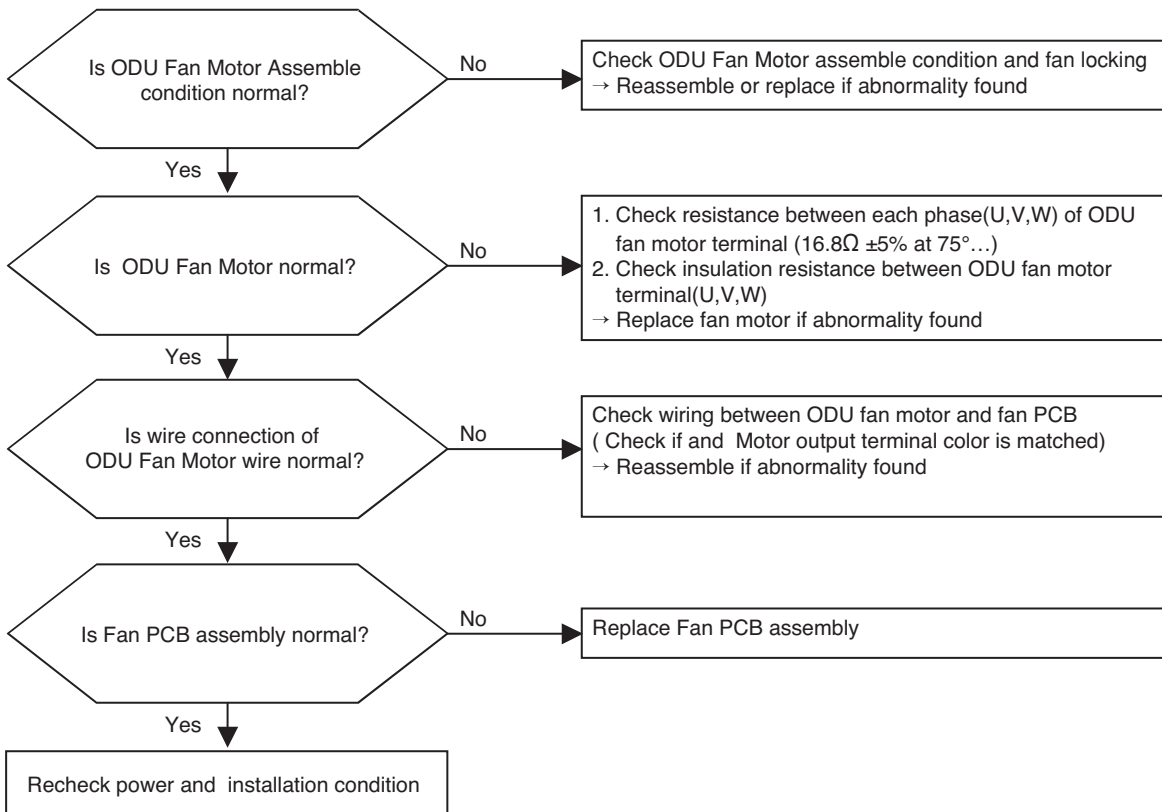

\* Fan Motor resistance measuring between each phase



\* Fan left(1)



\* Fan right(2)



## Trouble Shooting Guide

Error No.	Error Type	Error Point	Main Reasons
71* Master 711 Slave1 712 Slave2 713 Slave3 714	Converter CT Sensor Error	Micom input voltage isn't within $2.5V \pm 0.3V$ at initial state of power supply	1. Input Voltage is abnormal (R-N) 2. ODU Converter PCB damage (CT sensing part)

### ■ Error diagnosis and countermeasure flow chart

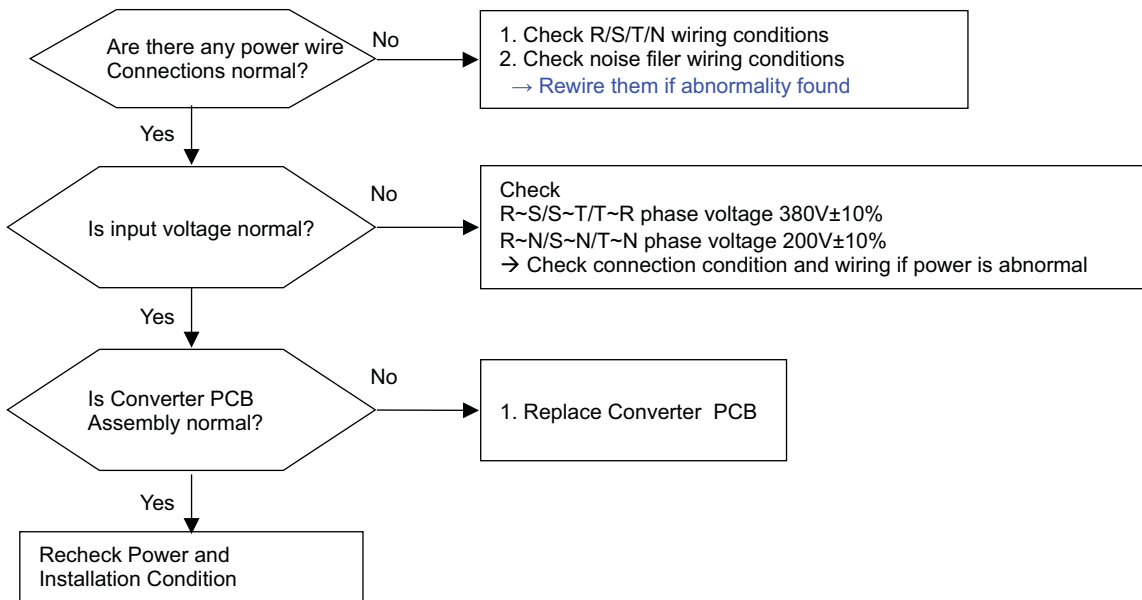

#### \* Measuring input voltage



#### \* Converter PCB assembly

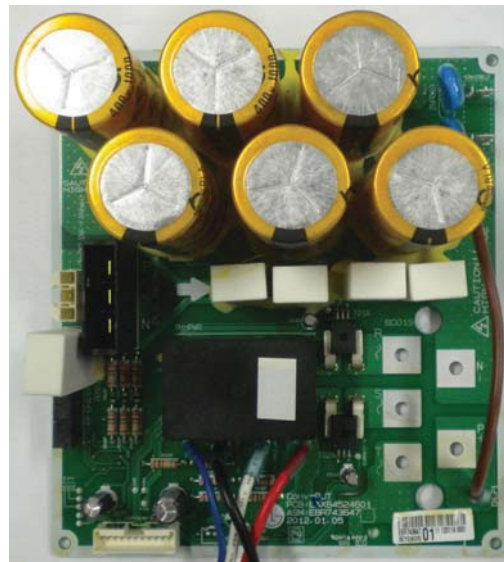

Error No.	Error Type	Error Point	Main Reasons
75* Master Slave1 Slave2 Slave3	Fan CT Sensor Error	Offset of Micom which sensor the fan motor phase current is not 2.5V	1. Input Voltage is abnormal (not 15V) 2. Fan PCB assembly defect 3. Power wire open and connecting fault 4. Inverter PCB assembly defect

■ Error diagnosis and countermeasure flow chart

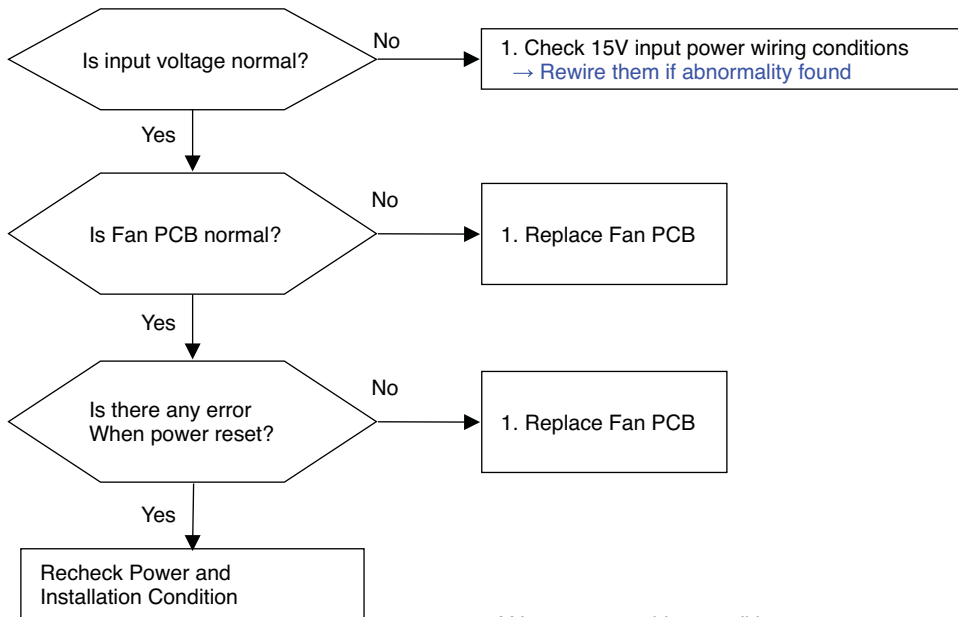

15V Input power wiring conditions



Check short of power wire

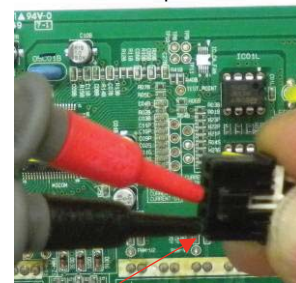

15V Input power on Inverter PCB

Error No.	Error Type	Error Point	Main Reasons
76* Master 761 Slave1 762 Slave2 763 Slave3 764	Fan DC Link High Voltage Error	Fan PCB DC link voltage supplied over 780V	1. Input voltage abnormal(R,S,T,N) 2. Fan PCB assembly defect 3. Power wire connecting fault

■ Error Diagnosis and Countermeasure Flow Chart

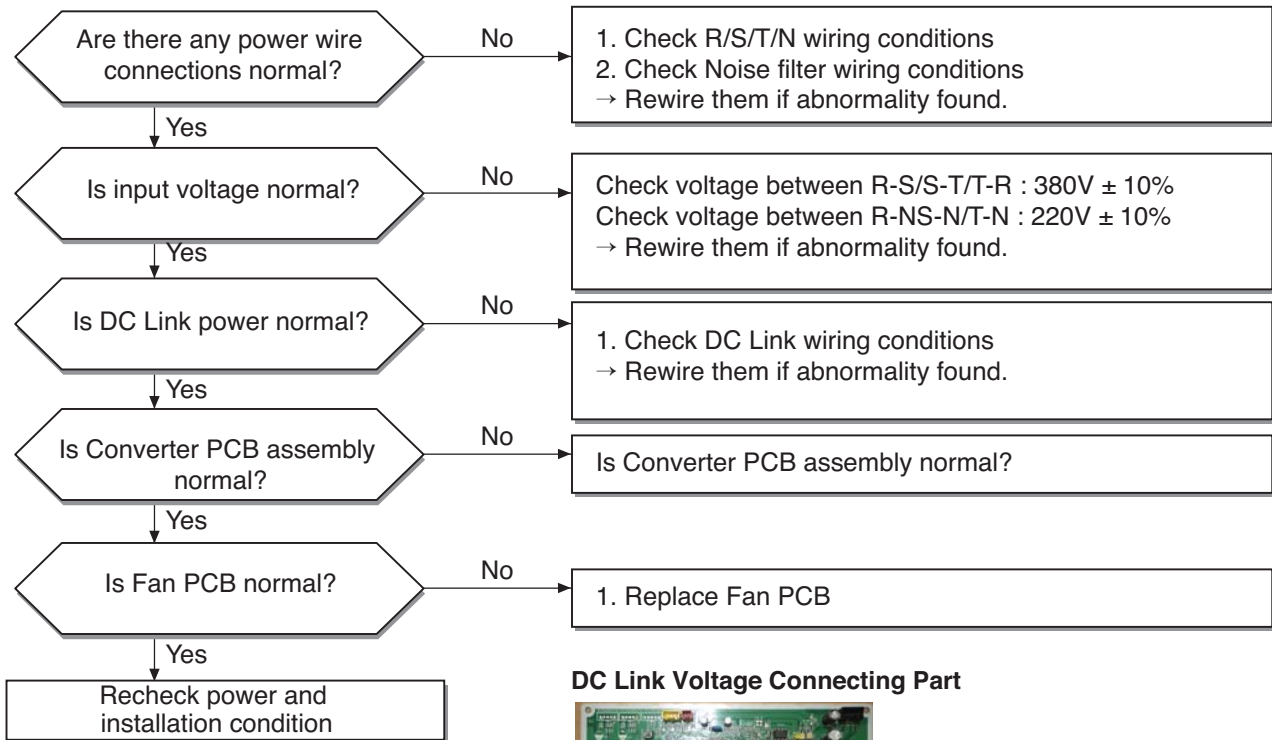

DC Link Voltage Connecting Part

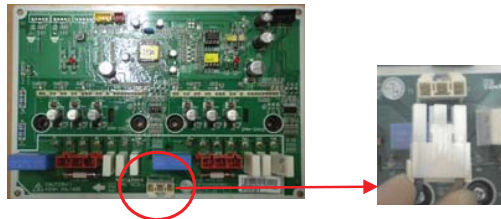

Noise filter wiring

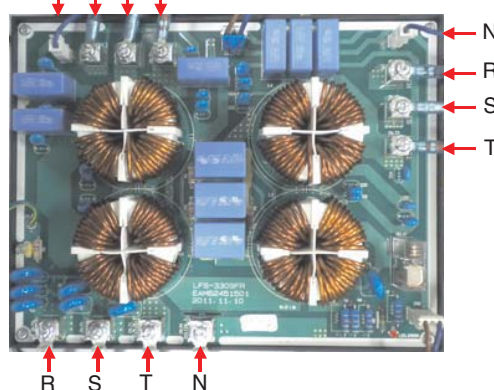

Error No.	Error Type	Error Point	Main Reasons
77* Master 771 Slave1 772 Slave2 773 Slave3 774	Fan Over Current Error	Output current is over 5A for 40ms	<ol style="list-style-type: none"> <li>1. Overload operation</li> <li>2. Fan Motor defect</li> <li>3. Fan PCB assembly defect</li> <li>4. Fan Motor connector insert defect</li> <li>5. Condenser icing or blocking</li> </ol>

■ Error Diagnosis and Countermeasure Flow Chart

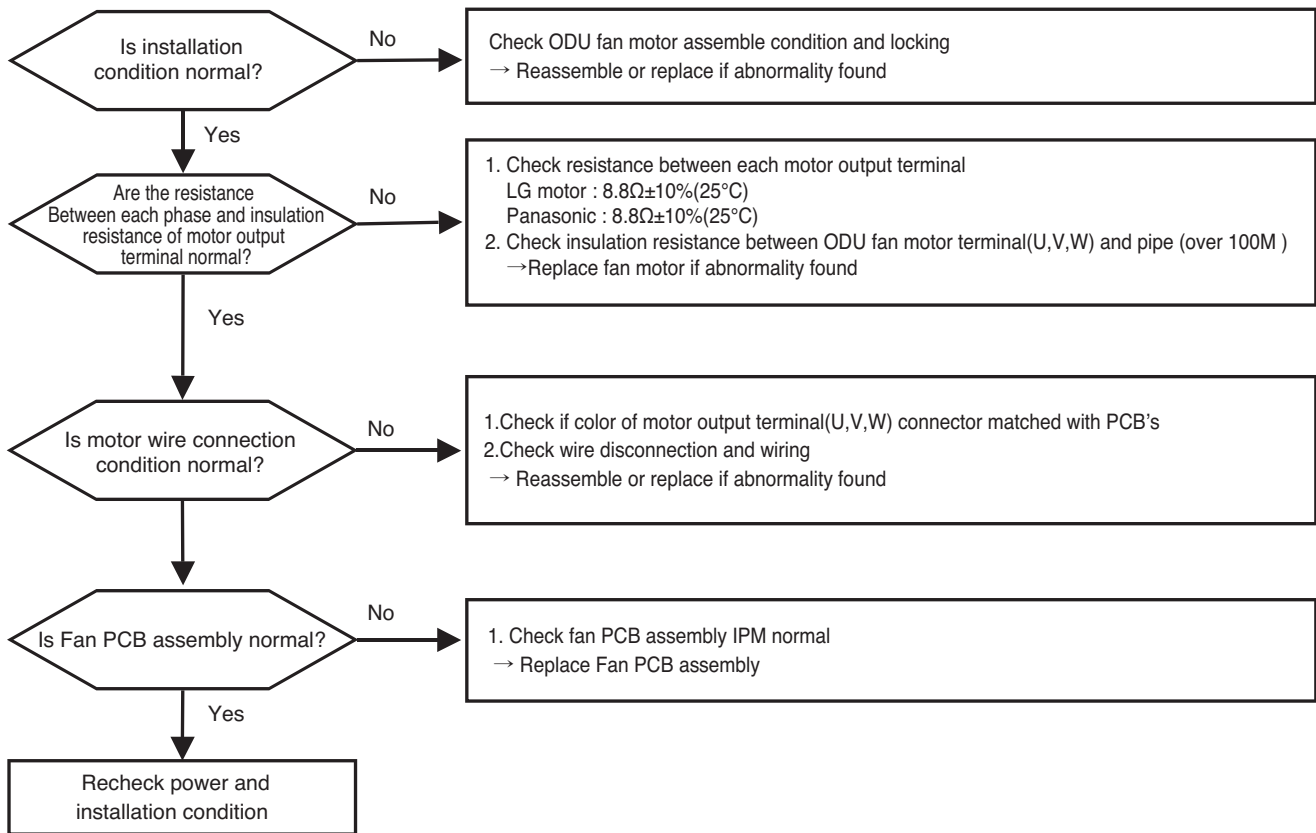

Measuring fan motor phase resistance



Fan left(1)



Fan right(2)



Error No.	Error Type	Error Point	Main Reasons
79* Master 791 Slave1 792 Slave2 793 Slave3 794	Fan Starting Failure Error	Fan Motor initial starting failure	1.Fan motor defect/ assemble condition abnormal 2.Fan motor connector misconnection(U,V,W output) 3.Fan PCB defect

■ Error Diagnosis and Countermeasure Flow Chart

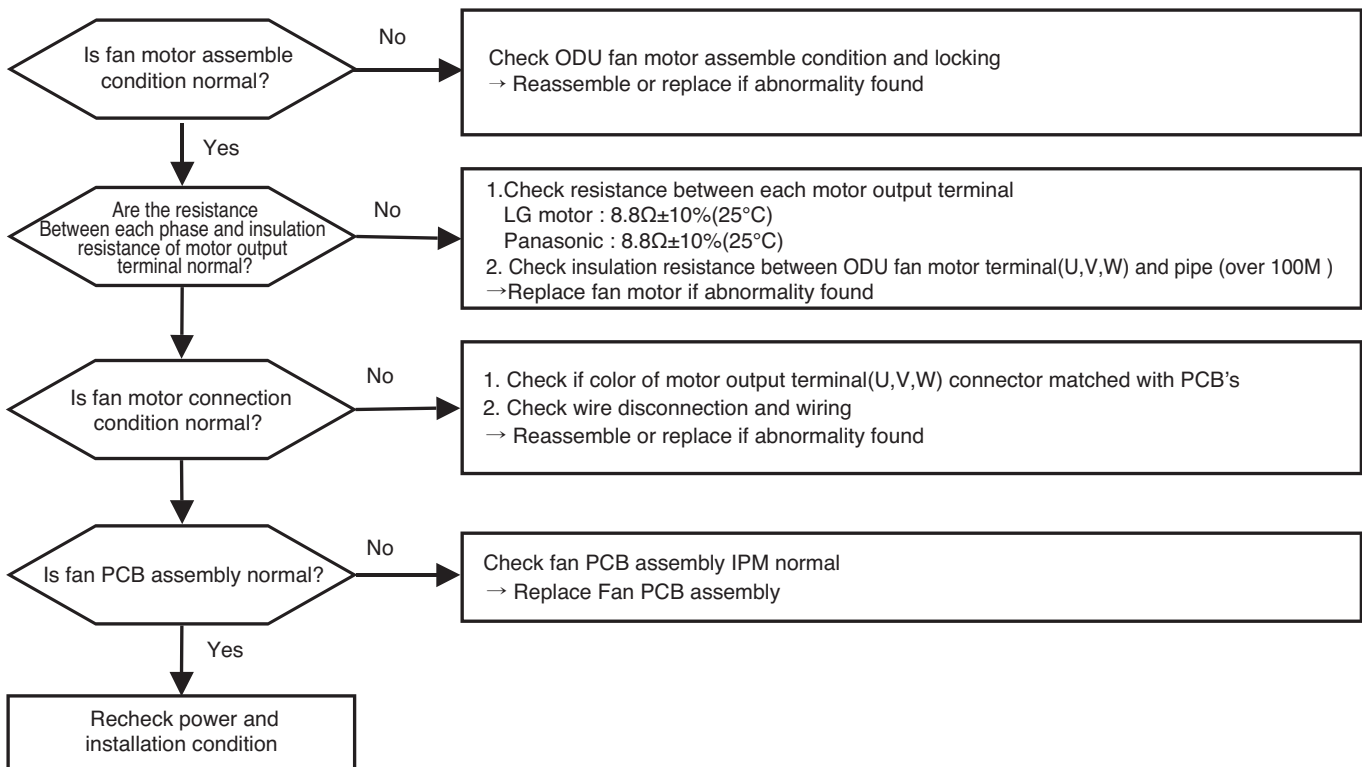

Measuring fan motor phase resistance



Measuring insulation resistance between fan terminal & chassis



Fan motor wire connection

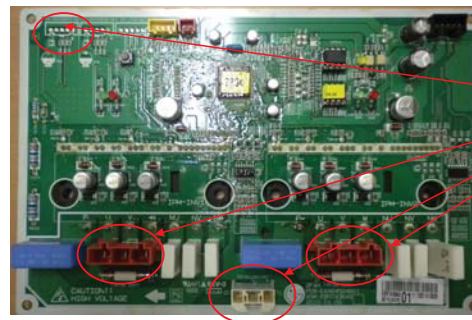

Check Point

Error No.	Error Type	Error Point	Main Reasons
86* Master 861 Slave1 862 Slave2 863 Slave3 864	Main PCB EEPROM	EEPROM Access Error	1. No EEPROM 2. EEPROM wrong insertion

■ Error Diagnosis and Countermeasure Flow Chart

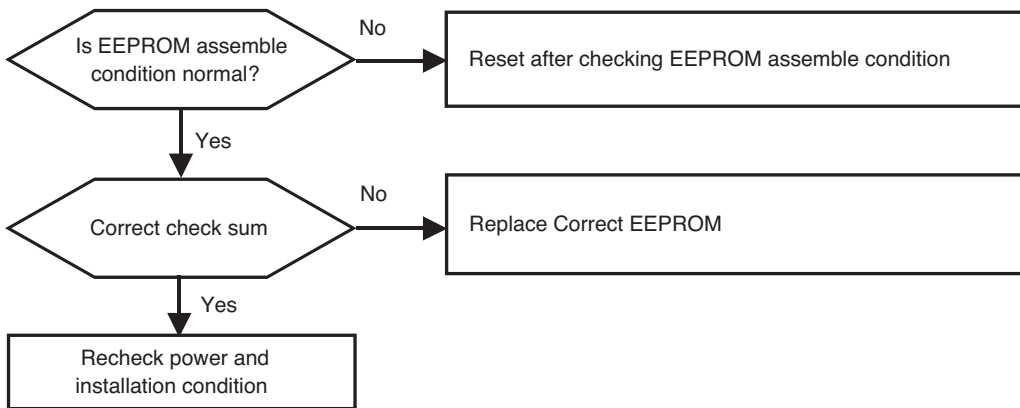

EEPROM Insertion

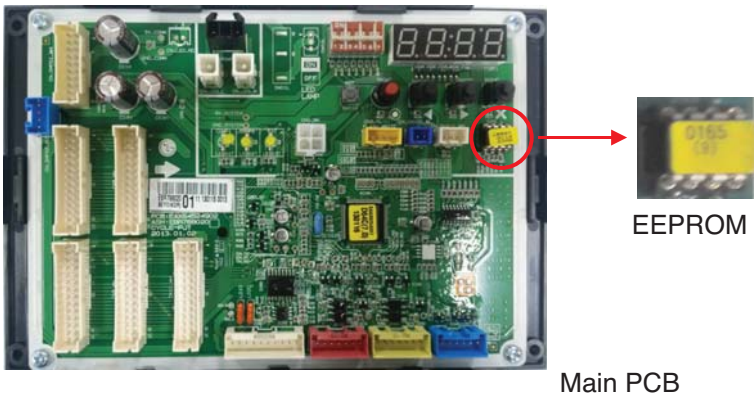

\* Note : Replace after power off



Error No.	Error Type	Error Point	Main Reasons
87* Master 871 Slave1 872 Slave2 873 Slave3 874	Fan PCB EEPROM Error	Error occurs when checking the EEPROM checksum as initializing after power is supplied	1.EEPROM bad contact/wrong insertion 2.EEPROM Version is different 3.ODU fan PCB assembly damage

■ Error Diagnosis and Countermeasure Flow Chart

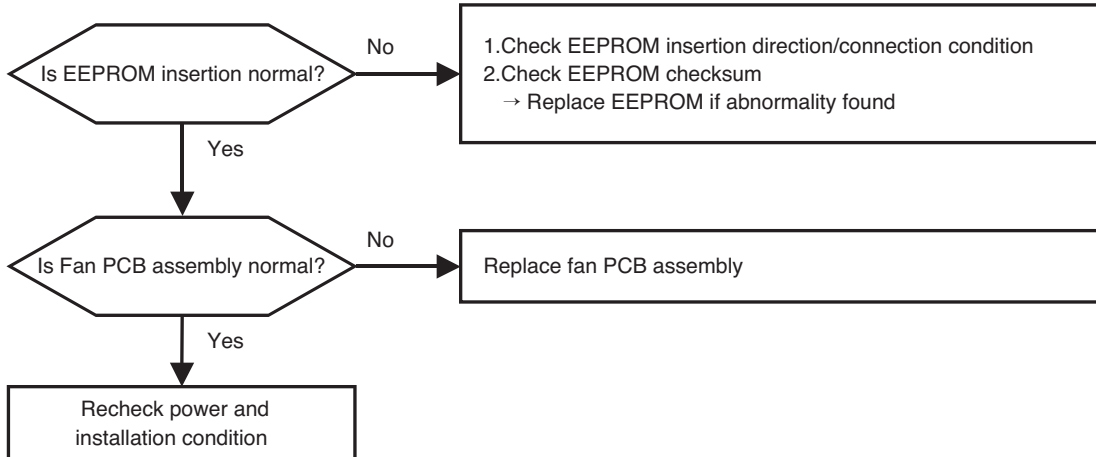

1 Fan

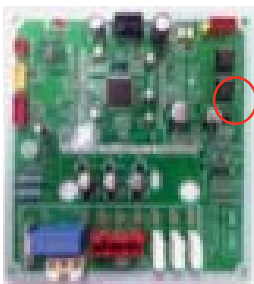

Check IC02L

2 Fan



Check IC02L

Inverter EEPROM insertion direction



Same direction both socket hole and EEPROM hole

\* Note : Replace after power off

Error No.	Error Type	Error Point	Main Reasons
104* Master 1041 Slave1 1042 Slave2 1043 Slave3 1044	Communication Error Between Outdoors	Master displays ODU number which is not communicated. Slave displays own error number	1.Loose connection of power cable/ communi- cation cable,(Open/Short) 2.Defect of each outdoor unit PCB

■ Error Diagnosis and Countermeasure Flow Chart

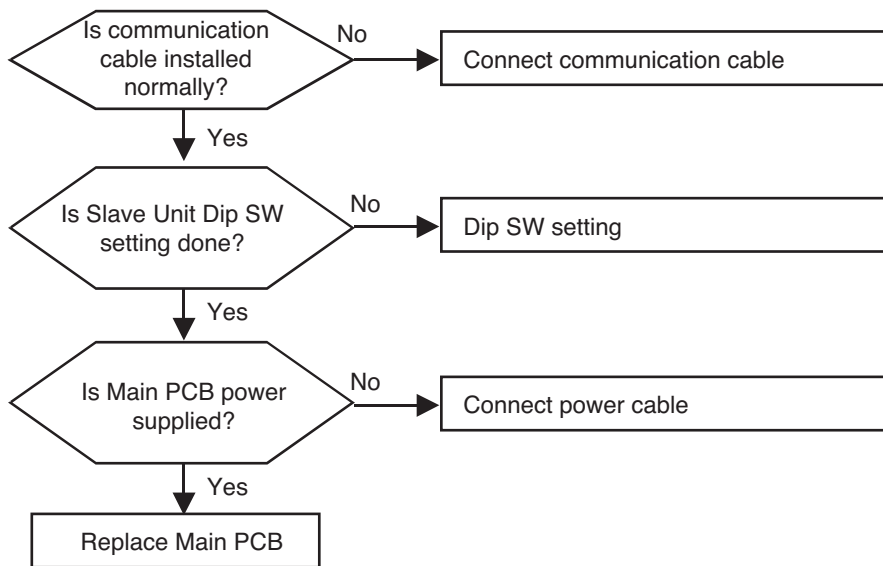

Error No.	Error Type	Error Point	Main Reasons
105* Master 1051 Slave1 1052 Slave2 1053 Slave3 1054	Communication error (Fan PCB ↔ Comp PCB)	Fan controller didn't receive signal from Comp PCB	1. Wrong connection between Comp and Fan PCB 2. Fan PCB power not supplied 3. ODU Comp/Fan PCB defect

**■ Error Diagnosis and Countermeasure Flow Chart**

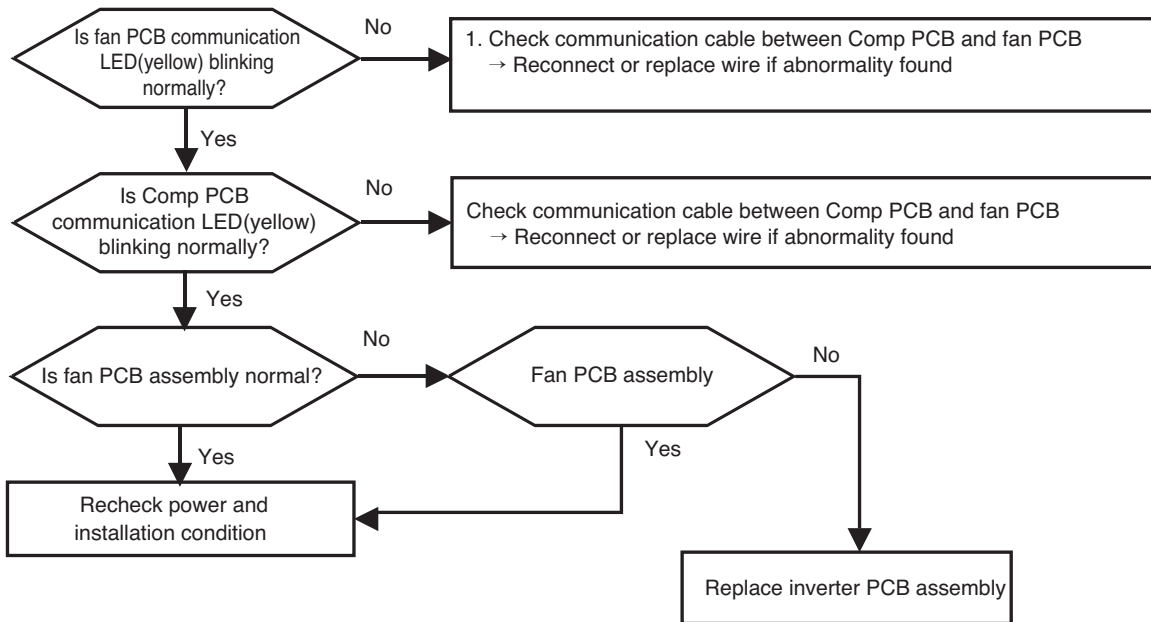

**Comp ↔ Fan Communication Connection**

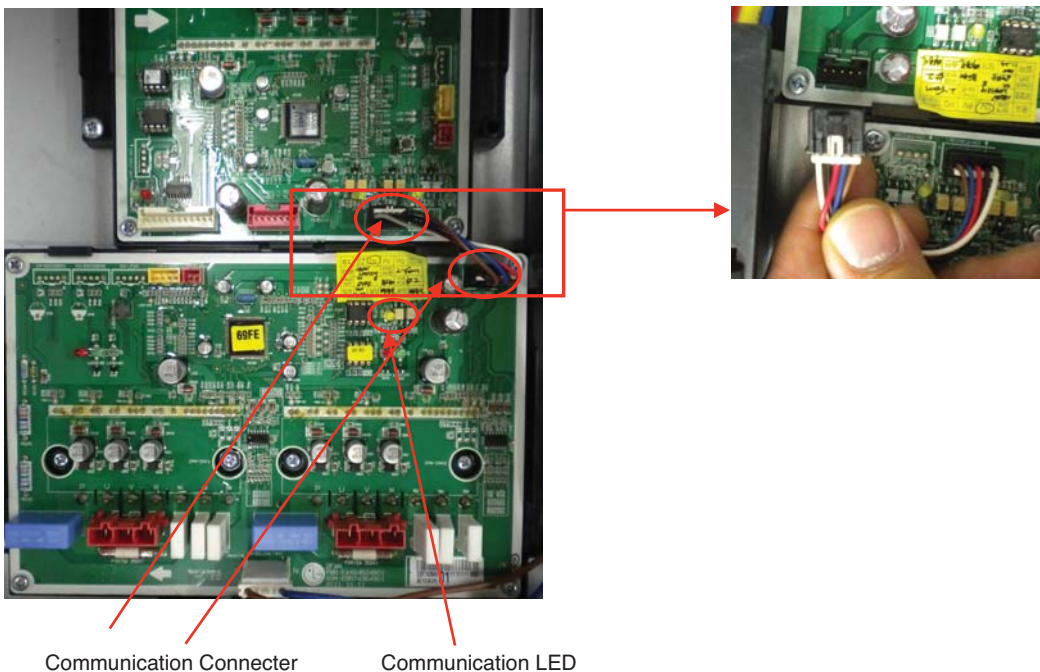

Error No.	Error Type	Error Point	Main Reasons
106 * Master 1061 Slave2 1062 Slave3 1064	ODU Fan PCB IPM Fault	IPM protection circuit activation (over current)	1. Overload operation (Pipe clogging/Covering/EEV defect/Ref. overcharge) 2. ODU fan motor assemble condition abnormal (Coil disconnection/Short/Insulation damage) 3. Fan PCB assembly defect

■ Error Diagnosis and Countermeasure Flow Chart

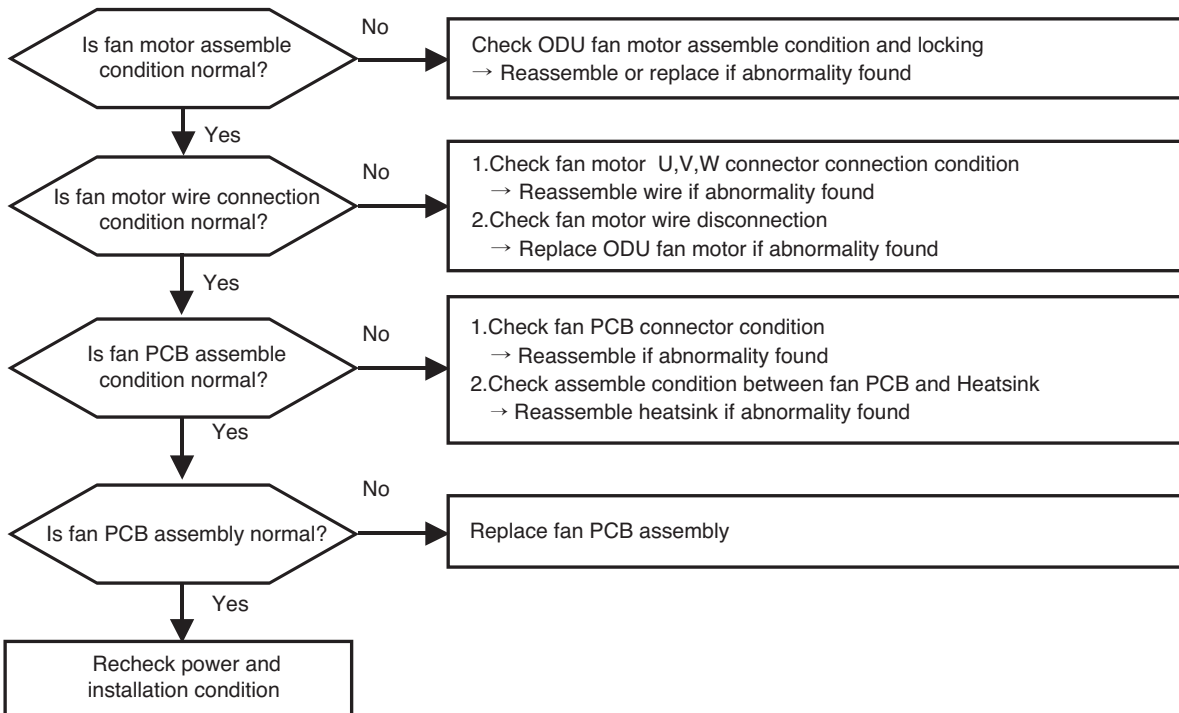

Fan Motor Wire connection

Fan left(1)



Fan right(2)



Error No.	Error Type	Error Point	Main Reasons
107 * Master 1071 Slave2 1072 Slave3 1074	Fan DC Link Low Voltage Error	Fan PCB DC link voltage supplied below 380V	<ol style="list-style-type: none"> <li>1. Wrong wiring between Converter PCB and Fan PCB</li> <li>2. Fan PCB assembly defect</li> <li>3. Reactor terminal contact defect</li> <li>4. DC link terminal wiring/contact defect</li> <li>5. Bridge diode defect</li> </ol>

■ Error Diagnosis and Countermeasure Flow Chart

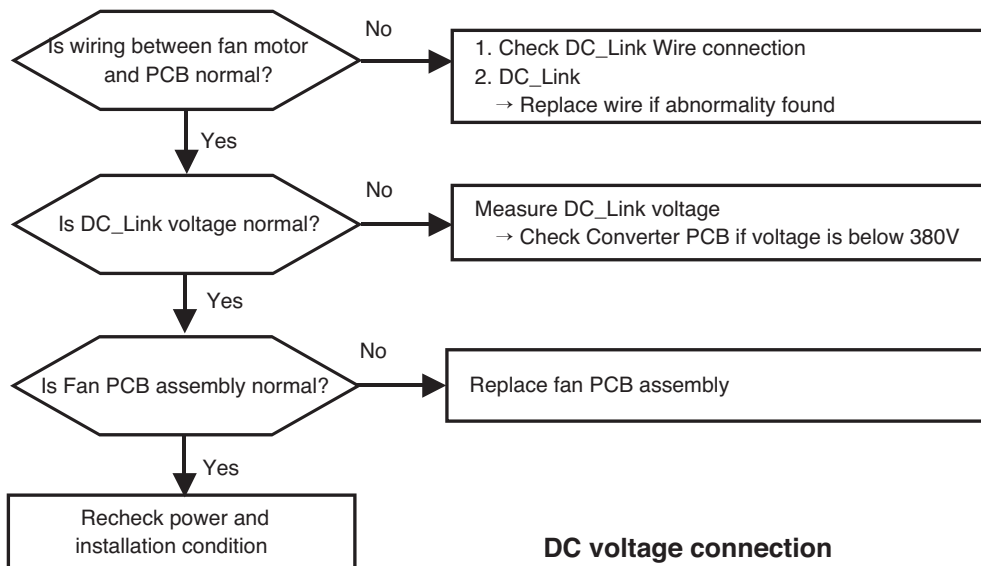

DC voltage connection



DC Volt connected

Error No.	Error Type	Error Point	Main Reasons
113* Master 1131 Slave1 1132 Slave2 1133 Slave3 1134	Outdoor unit liquid pipe (condenser) temperature sensor error	Abnormal sensor resistance value (Open/Short)	1. Defective temperature sensor connection 2. Defective temperature sensor (Open / Short) 3. Defective outdoor unit PCB
114* Master 1141 Slave1 1142 Slave2 1143 Slave3 1144	Outdoor Unit Subcooling Inlet Temperature Sensor Error	Abnormal sensor resistance value (Open/Short)	1. Defective temperature sensor connection 2. Defective temperature sensor (Open/Short) 3. Defective outdoor PCB
115* Master 1151 Slave1 1152 Slave2 1153 Slave3 1154	Outdoor Unit Subcooling Outlet Temperature Sensor Error	Abnormal sensor resistance value (Open/Short)	1. Defective temperature sensor connection 2. Defective temperature sensor (Open/Short) 3. Defective outdoor PCB

**■ Error diagnosis and countermeasure flow chart**

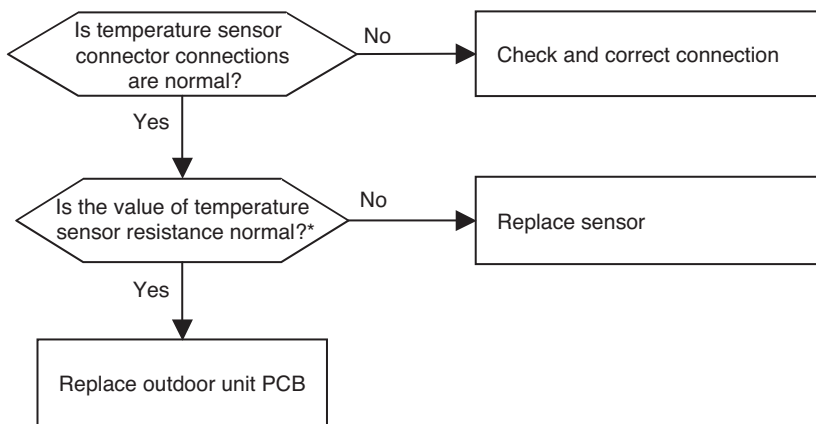

\* Sensor resistance 100 kΩover (open) or 100 Ω below (short) will generate error

Note: Temperate sensor resistance vary with temperature, So compare temperature sensor resistance value according to outdoor unit temperature by referring below table (±5% tolerance)

Air temperature sensor: 10°C = 20.7kΩ : 25°C = 10kΩ : 50°C= 3.4kΩ

Pipe temperature sensor: 10°C = 10kΩ : 25°C = 5kΩ : 50°C= 1.8kΩ

Error No.	Error Type	Error Point	Main Reasons
145* Master 1451 Slave1 1452 Slave2 1453 Slave3 1454	Communication Error between (Main PCB → External PCB)	Cycle controller of Master unit can't receive signal from External controller	1. Power cable or communication cable is not connected 2. Defect of outdoor Cycle/External PCB

■ Error diagnosis and countermeasure flow chart

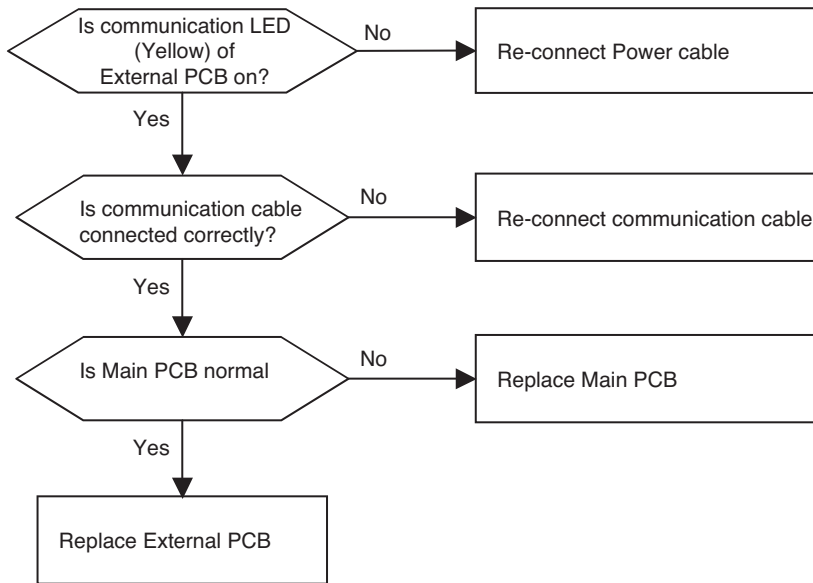

\* The Method of checking Main PCB and External PCB (If normal, communication LED blinks)



External Communication Connector

**Communication Connector & LED in Main PCB**



**Communication Connector & LED in External PCB**

Error No.	Error Type	Error Point	Main Reasons
151* Master 1511	Function error of outdoor 4way (reversing valve)	Function error of 4way (reversing valve) in Main or Slave outdoor units	1. Wrong operation of 4way valve because of sludge etc. inflow 2. No pressure difference because of compressor fault 3. Wrong installation of In/outdoor common pipe 4. Defect of 4way valve

■ Error diagnosis and countermeasure flow chart

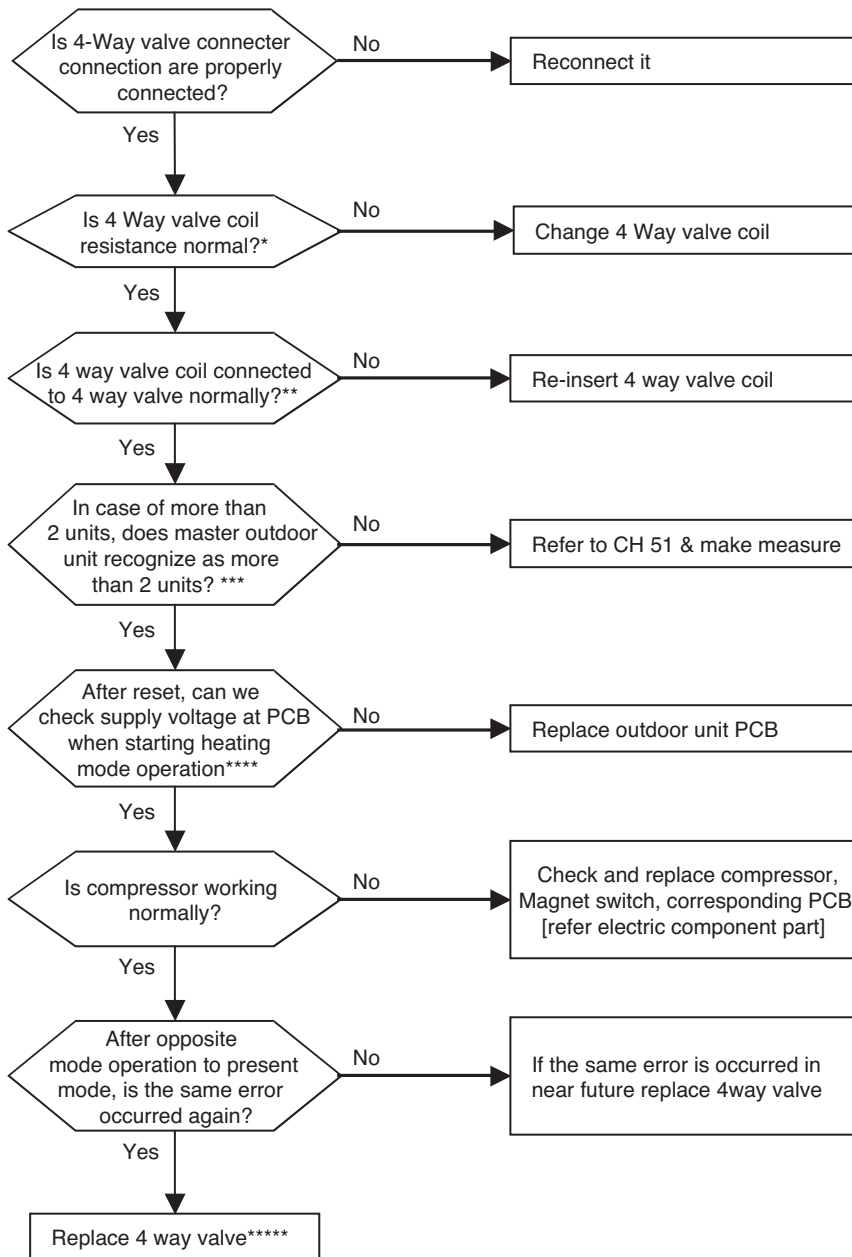

## Trouble Shooting Guide

\* Measure the resistance of 4way valve

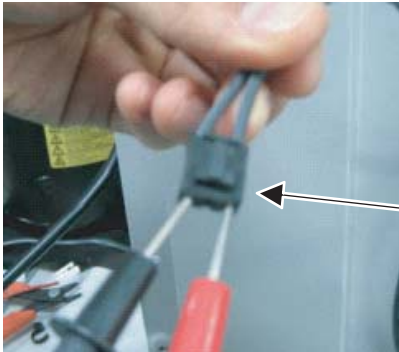

Location of 4way valve connector on Main PCB (marked as 4way, CN09)



\*\* Confirm the 4way valve coil is inserted to the end



\*\*\*\* Check the output voltage of terminal socket during heating operation

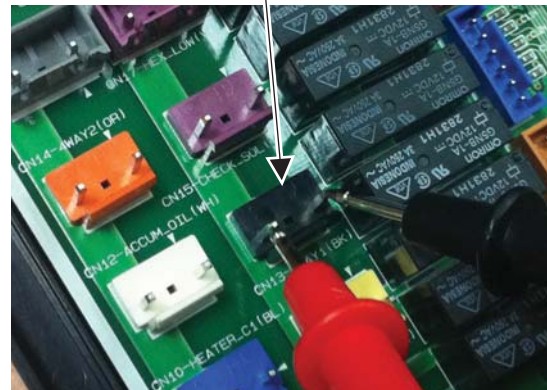

\*\*\* When power is supplied in order as follow

(Slave2 → Slave1 → Mater)

ODU information is displayed one after the other at main PCB 7-segment

1. Model ID

→ 8HP : 8, 10HP : 10, 12HP : 12, 14HP : 14, 16HP : 16, 18HP : 18, 20HP : 20

2. Total Capacity

→ Displayed with HP

3. ODU Type

→ Cooling only :1

→ Heat pump :2

4. Power type

→ 380V : 38

5. Model type

→ LTE4:1

→ LTS4:2

\*\*\*\*\* Checking method for outdoor unit of 3unit system

(Master + Slave1 + Slave2)

① Close all the SVC valves of high / low pressure

② Operate system

③ Check the difference of high and low pressure with LGMV for each unit (Master, Slave1, Slave2)

④ If there is a unit in which the difference is not increased then the 4way valve of that unit is defective

Error No.	Error Type	Error Point	Main Reasons
182* Master 1821 Slave1 1822 Slave2 1823 Slave3 1824	Communication Error Between Main and Sub Micom of External PCB	Failure Receiving Signal Between Main and Sub Micom	1. Failure Receiving Signal Between Main and Sub Micom

■ Error diagnosis and countermeasure flow chart

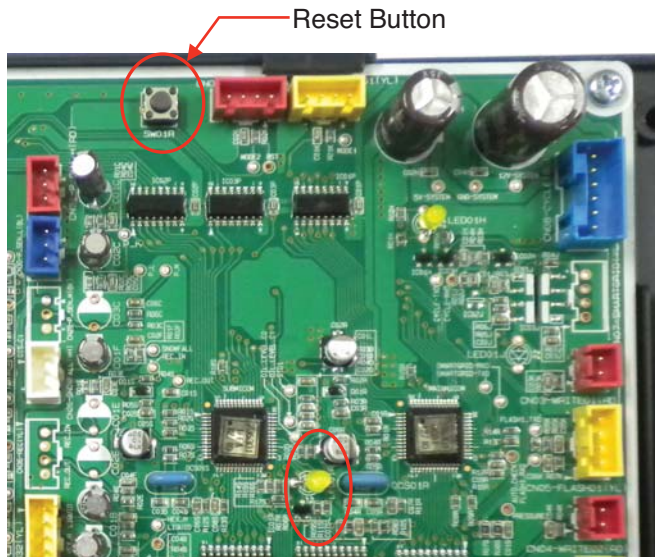
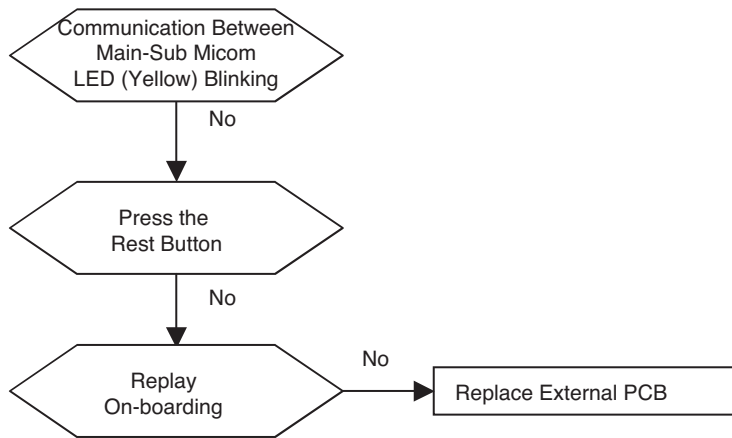

Reset Button  
Communication LED  
Between Main and Sub Micom

Error No.	Error Type	Error Point	Main Reasons
193* Master 1931 Slave1 1932 Slave2 1933 Slave3 1934	Fan PCB Heatsink Temperature High	Heatsink Temperature is Over 90°C	<ol style="list-style-type: none"> <li>1. Fan PCBA IPM Connection Condition Abnormal</li> <li>2. Outdoor Unit Fan Motor Operation Abnormal</li> <li>3. Outdoor Unit Fan PCB Assembly Defect</li> <li>4. Overload Operation (Pipe Clogging/ Covering/EEV Defect/Ref. Overcharge)</li> </ol>

■ Error diagnosis and countermeasure flow chart

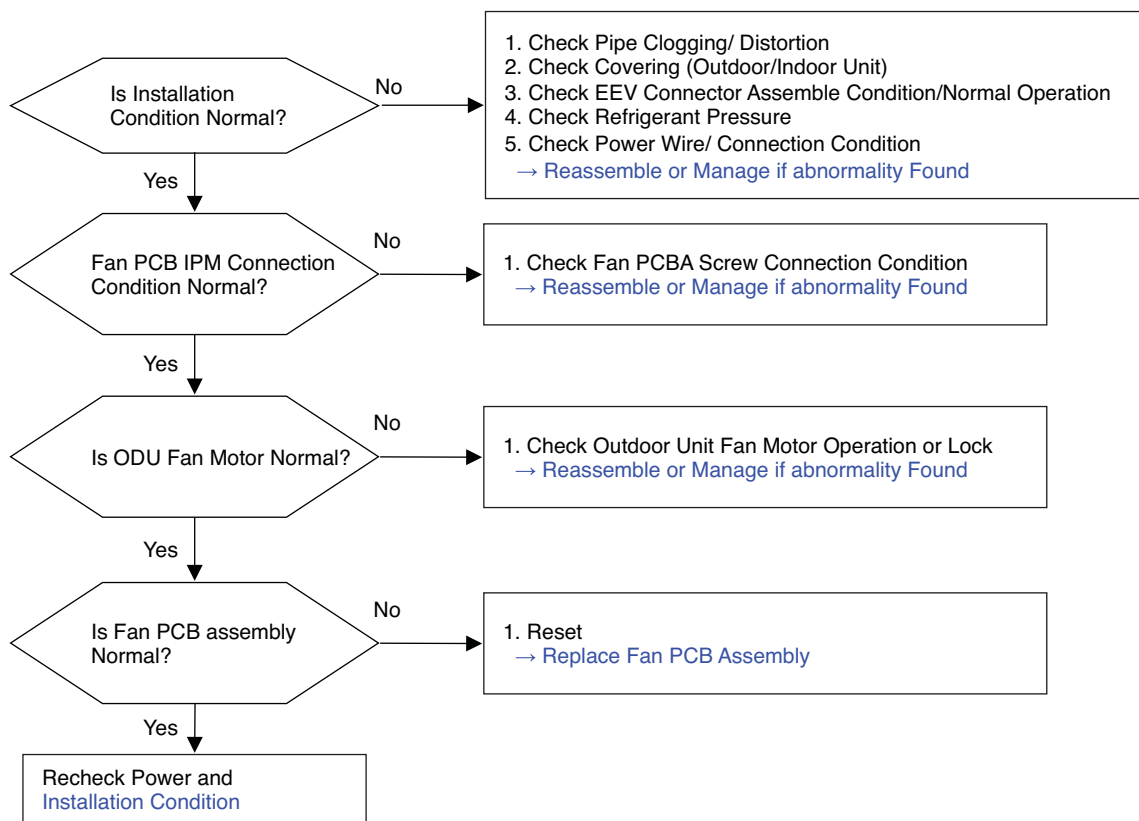

■ Check Fan PCB Screw Connection Condition

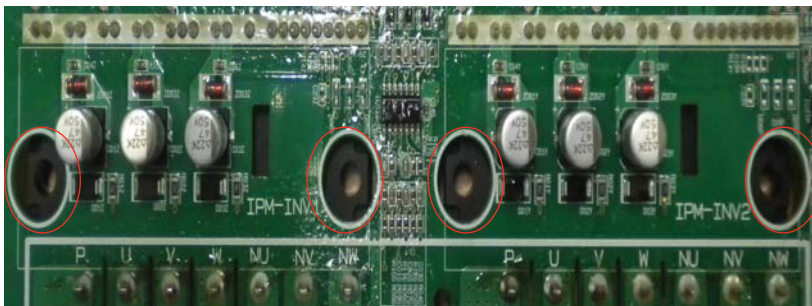

Check Screw Connection Condition

Error No.	Error Type	Error Point	Main Reasons
194* Master 1941 Slave1 1942 Slave2 1943 Slave3 1944	Outdoor unit Fan PCB heatsink temperature sensor error	Outdoor unit Fan PCB heatsink temperature sensor error	1. Defective temperature sensor connection 2. Defective temperature sensor (Open / Short) 3. Defective outdoor unit PCB

■ Error diagnosis and countermeasure flow chart

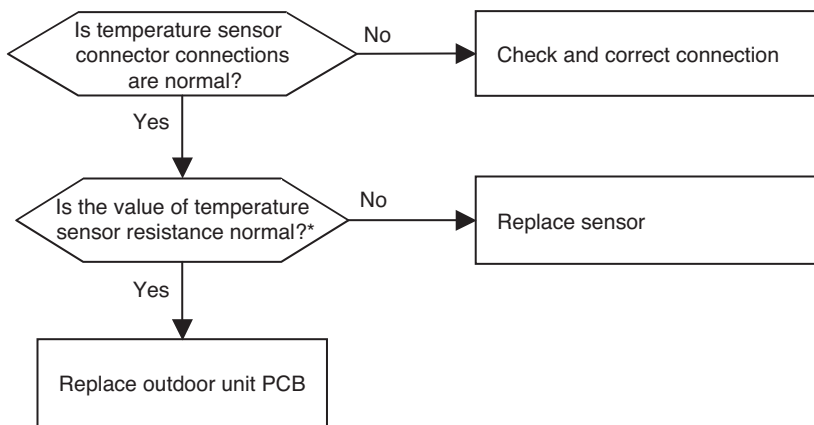

\* Sensor resistance 100 kΩ over (open) or 100 Ω below (short) will generate error

Note: Temperate sensor resistance vary with temperature, So compare temperature sensor resistance value according to outdoor unit temperature by referring below table (±5% tolerance)

Air temperature sensor: 10°C = 20.7kΩ : 25°C = 10kΩ : 50°C= 3.4kΩ

Pipe temperature sensor: 10°C = 10kΩ : 25°C = 5kΩ : 50°C= 1.8kΩ

## Trouble Shooting Guide

Error No.	Error type	Error point	Main reasons
201C#HR	HR unit liquid pipe temperature sensor error	Abnormal value of sensor measurement (Open / Short)	<ul style="list-style-type: none"> <li>Defective temperature sensor connection</li> <li>Defective temperature sensor (Open/Short)</li> <li>Defective outdoor unit PCB</li> </ul>

Error No.	Error type	Error point	Main reasons
202C#HR	HR unit Sub-cooling inlet pipe temperature sensor error	Abnormal value of sensor measurement(Open / Short )	<ul style="list-style-type: none"> <li>Defective temperature sensor connection</li> <li>Defective temperature sensor (Open/Short)</li> <li>Defective outdoor unit PCB</li> </ul>

Error No.	Error type	Error point	Main reasons
203C#HR	HR unit Sub-cooling discharge pipe temperature sensor error	Abnormal value of sensor measurement(Open / Short)	<ul style="list-style-type: none"> <li>Defective temperature sensor connection</li> <li>Defective temperature sensor (Open/Short)</li> <li>Defective outdoor unit PCB</li> </ul>

### ■ Error diagnosis and countermeasure flow chart

- 1) Check connection condition of temperature sensor and lead cable
- 2) Is value of temperature sensor normal? If not replace sensor  
 - Piping temperature sensor : 10°C(50°F) = 10kΩ : 25°C(77°F)= 5kΩ : 50°C(122°F)= 1.8kΩ
- 3) If connection of sensor and value is correct, replace outdoor unit PCB

### ■ HR unit error display No.

HR Unit	HR #1	HR #2	HR #3	HR #4	HR #5	HR #6	HR #7	HR #8	HR #9	HR #10	HR #11	HR #12	HR #13	HR #14	HR #15	HR#16
Error display	C01	C02	C03	C04	C05	C06	C07	C08	C09	C10	C11	C12	C13	C14	C15	C16

### ■ Example of HR unit error display.

#16 HR unit Sub-cooling inlet pipe temperature sensor error 200 → C16 (Repeat)

C: HR unit

#: HR unit Nuber

Error No.	Error type	Error point	Main reasons
204C#HR	Transmission error between the HR unit and outdoor unit	Transmission error between the HR unit and outdoor unit	1. Defective connection in HR unit power supply and communication connection 2. Wrong setting of the HR unit rotary switch and dip switch 3. Defective HR unit PCB

**■ Error diagnosis and countermeasure flow chart**

- 1) Check connection between power cables and communication cables, check communication green LED blink of HR unit PCB
  - 2) If communication green LED blink of HR unit PCB is normal, check setting of rotary switch of HR unit and dip switch(Refer to CH200),  
Reset power of outdoor and HR unit  
(If communication error of HR unit occurs, it can't be released until reset of outdoor power)
  - 3) If communication green LED blink of HR unit PCB is abnormal(not blinking,just on), check communication condition of total indoor units(Refer to CH05)  
If communication green LED blink of HR unit PCB is abnormal(not blinking, just on) even if communication condition is normal, replace HR unit PCB
- [NB] If Indoor units/communication cables of HR unit and cables of power 220V has been changed each other, communication parts and indoor will be burnt

**HR Unit PCB**

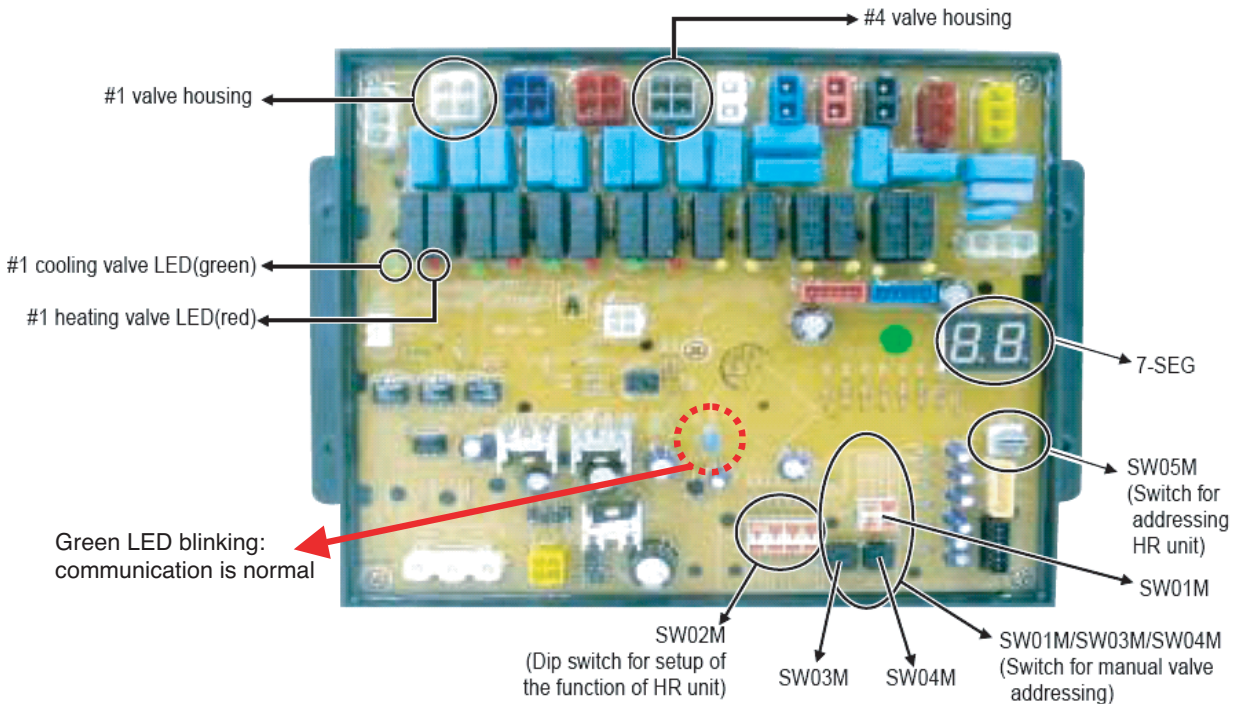

Error No.	Error Type	Error Point	Main Reasons
242* Master 2421	Network Error	Network error of central controller	1. RS-485 communication wiring defect 2. Communication defect between remote controller and indoor unit 3. RS-485 dip switch setting error 4. Indoor unit addressing ssetting error on central controller

■ Error diagnosis and countermeasure flow chart

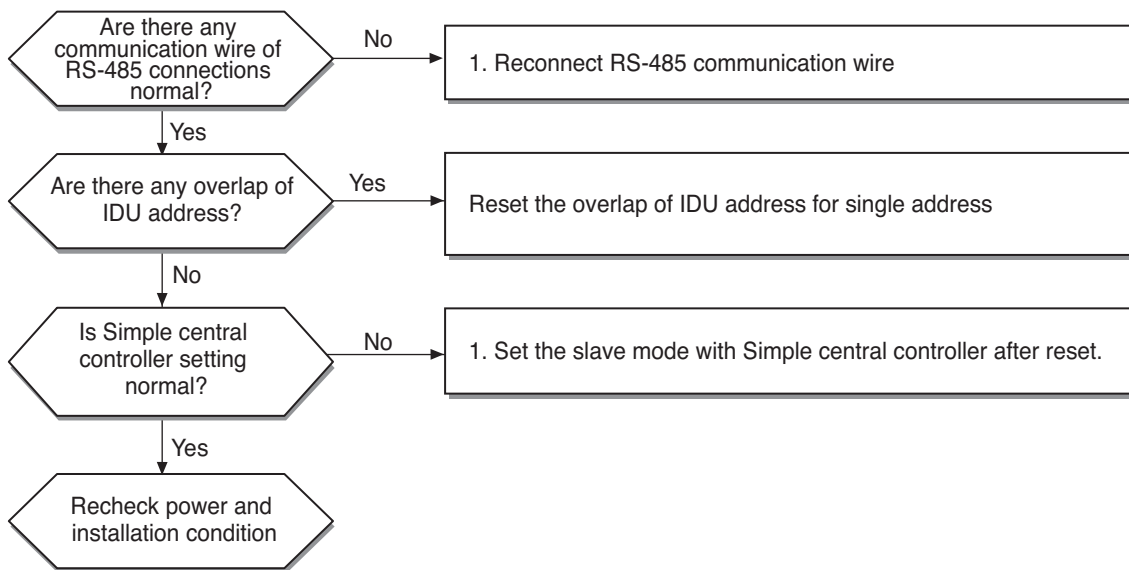

<RS-485 communication wire miss connection>

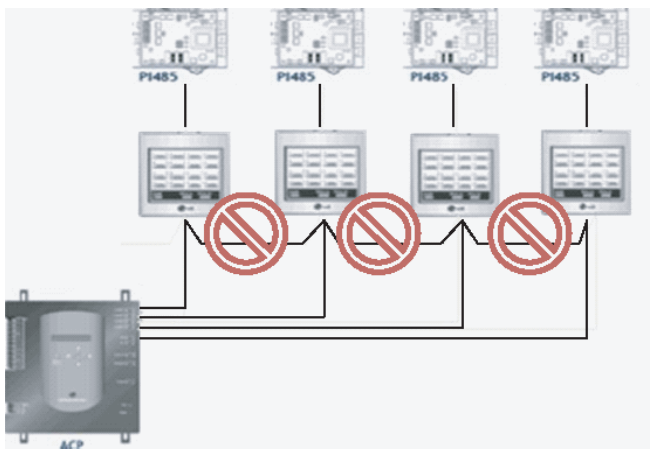



P/NO : MFL67369012

February, 2016